

# ENGINE EXPERTISE

BY  **FEDERAL-MOGUL**  
MOTORPARTS

# 4



Alfa / Fiat / Lancia  
Iveco

CATMX1501



# 2015-2016



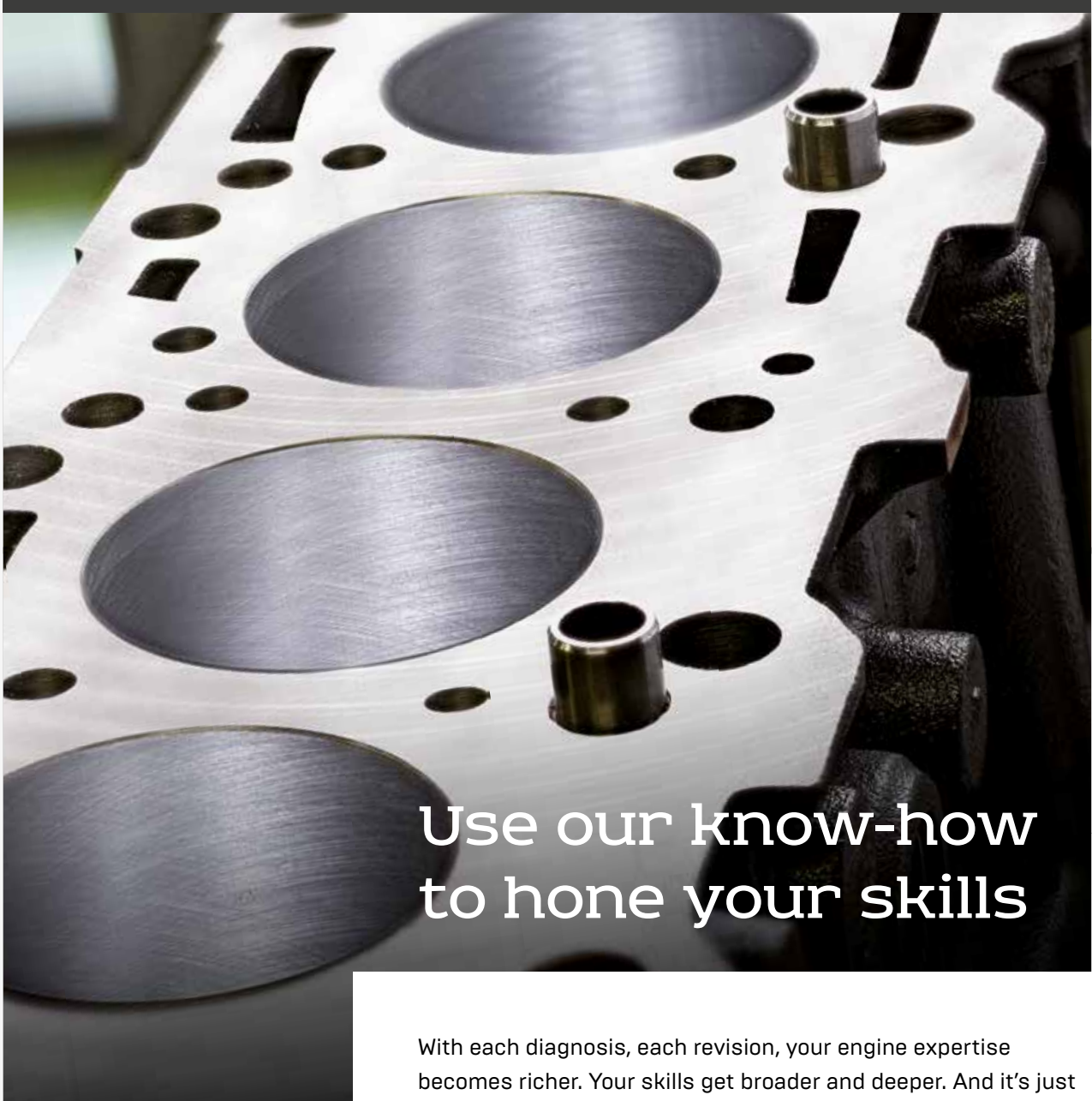

## Use our know-how to hone your skills

With each diagnosis, each revision, your engine expertise becomes richer. Your skills get broader and deeper. And it's just the same at Federal-Mogul. That's why people rely on you. For example, your eye for detail and your feel for precise cylinder liner honing guarantee optimum engine performance. Your expertise helps us understand which parts you need, and how we can give you even more support to make it easier for you to achieve perfection with each engine job.

**Because our engine expertise... is based on yours.**



**ENGINE EXPERTISE**  
BY  **FEDERAL-MOGUL**  
MOTORPARTS



*Nirral*



# INTRODUCTION

---

Dear Federal-Mogul Motorparts partner,

Welcome to the fourth volume of the *Federal-Mogul Motorparts Engine Expertise catalogue*. All engine and sealing parts for Alfa, Fiat, Lancia and Iveco light vehicle engines are covered in this catalogue, which is compiled to meet the requirements and increase the efficiency of engine rebuilders and service technicians working on these vehicles.

Federal-Mogul is an innovative and diversified global supplier of quality products, trusted brands and creative solutions for the OE market. We prioritise value creation through technology and innovation in products, processes and services, which makes us the preferred supplier to the global OE market.

## **The complete service for Italian engine rebuild specialists**

Federal-Mogul Motorparts's new catalogue provides specialists rebuilding Italian engines with the latest, trusted OE specification technologies from a one-stop-shop. Our customers get to feel the benefit of Federal-Mogul's extensive experience in developing innovative products and also its range of expert brands that include: AE<sup>®</sup> for valvetrain, camtrain and belts; Payen<sup>®</sup> gaskets, sets, seals and headbolts; Nüral<sup>®</sup> pistons and assemblies; Goetze<sup>®</sup> piston rings and liners; and Glyco<sup>®</sup> engine bearings. All manufactured to exacting OE specification.

## **Future successes and reduced emissions**

Federal-Mogul focuses on the quality and innovation that helps our global vehicle manufacturer customers continue to increase durability and drive down harmful CO<sub>2</sub> emissions. This proven expertise recognized through our brands is highly regarded by engine rebuild specialists worldwide.

Federal-Mogul's established business partnerships provide a reliable support network committed to servicing the needs of the automotive market, which helps optimise businesses' working practices and results in customer satisfaction.

We hope you enjoy the benefits of this catalogue!

Mark Whitehead,  
Global Product Director Engine



Alexis Goslin,  
Business Director Sealing,  
Engine & Underhood Service EMEA



# CONTENT

## EN

Content	II
How to use this catalogue	IV - VII
Terms of business	XXXVI
Model index	XXXVIII - LXIII
Engine index	LXIV - LXXIX
Top engine applications	1
Bottom engine applications	425
Numerical parts list	851
OE interchange	914
Valve guides	926
Oil seals	928
Cylinder headbolts	930
Technical notes	932

## DE

Inhaltsverzeichnis	II
So benutzen Sie diesen Katalog	VIII - XI
Geschäftsbedingungen	XXXVI
Modelverzeichnis	XXXVIII - LXIII
Motorindex	LXIV - LXXIX
Zylinderkopfanwendungen	1
Motorblockanwendungen	425
Nummerische Teilleiste	851
OE-Entsprechungen	914
Ventilführungen	926
Wellendichtringe	928
Zylinderkopfschrauben	930
Technische Hinweise	933

## IT

Contenuto	II
Come si utilizza il catalogo	XII - XV
Condizioni generali	XXXVI
Indice de modello	XXXVIII - LXIII
Indice motore	LXIV - LXXIX
Applicazioni parte alta del motore	1
Applicazioni bassa inferiore del motore	425
Elenco riferimenti	851
Intercambio OE	914
Guidavalvole	926
Paraoli	928
Viti testa cilindro	930
Note tecniche	934

## FR

Contenu	II
Comment se servir de ce catalogue	XVI - XIX
Conditions générales de vente	XXXVI
Index de modèle	XXXVIII - LXIII
Index moteur	LXIV - LXXIX
Applications haut moteur	1
Applications bas moteur	425
Liste numérique des références	851
Liste d'équivalence Première Monte (OE)	914
Guides de soupape	926
Bagues d'étanchéité	928
Vis de culasse	930
Notes techniques	935

# CONTENT

## ES

Índice	III
Cómo utilizar este catálogo	XX - XXIII
Condiciones de venta	XXXVII
Índice de Modelo	XXXVIII - LXIII
Índice de motores	LXIV - LXXIX
Aplicaciones para la parte superior del motor	1
Aplicaciones para la parte inferior del motor	425
Lista de referencias	851
Cruce de referencias de equipo original	914
Guías de válvula	926
Retenes de aceite	928
Tornillos de culata	930
Notas técnicas	936

## PL

Spis treści	III
Jak używać tego katalogu	XXIV - XXVII
Warunki współpracy	XXXVII
Indeks modelu	XXXVIII - LXIII
Indeksy silników	LXIV - LXXIX
Góra silnika	1
Dół silnika	425
Lista części	851
Zamienniki OE	914
Prowadnice zaworów	926
Uszczelnienia olejowe	928
Śruby do głowicy cylindrów	930
Notatki techniczne	937

## RU

Содержание	III
Как пользоваться каталогом	XXVIII - XXXI
Условия делового сотрудничества	XXXVII
Модель автомобиля	XXXVIII - LXIII
Указатель двигателей	LXIV - LXXIX
Детали верхней части двигателя	1
Детали нижней части двигателя	425
Список номеров деталей	851
Взаимозаменяемость с оригинальными деталями	914
Направляющие клапанов	926
Сальники	928
Болты ГБЦ	930
Технические примечания	938

## AR

III	المحتوى
XXXV - XXXII	كيفية استخدام هذا الكatalog
XXXVII	شروط العمل
LXIII - XXXVIII	دليل المحرك
LXXIX - LXIV	مؤشر المحرك
1	تطبيقات المحرك العلوية
425	تطبيقات المحرك السفلية
851	قائمة القطع المرقمة
914	تبادل المعدة الأصلية
926	موجهات الصمامات
928	لعمود الكام
930	مسامير رأس الأسطوانة
939	المنذرة التقنية

# HOW TO USE THIS CATALOGUE

EN



FIAT GROUP				
172	80.50	Petrol		
159 A2.000	4 Cyl.	9.2:1	1372cc	57kW (78)PS
160 A1.000	4 Cyl.	9.2:1	1372cc	52-56kW (71-76)PS
836 A4.000	4 Cyl.	9.2:1	1372cc	51kW (69)PS

6	7	8	9	10	11
TB305 138x15	TBK027 Component No:TB305;AE1008TP	CAM719			FOL104 (x8) [8]
[8] Mécanique	[8] Mécanique	[8] Meccanico	[8] Mecánico		

12	OE	MAT.	19	20	21	22	23
V91300  13	7609772	MB	45°		H	VAG92366  13	
37.50 x 8.00 x 108.50  14	15	MD	45°			46.50 x 8.00 x 14.10  24	23
V90071  13	4315062	MD cr	45°				
30.99 x 8.00 x 109.09	4315062	MD cr	45°				
V91713  13		MD cr					
31.00 x 8.00 x 109.00							

- 1 Panel no.
- 2 Bore size
- 3 Engine detail
- 4 TecDoc / F-M engine no.
- 5 Corresponding bottom engine panel number
- 6 Timing belt references  
No. of teeth x belt width
- 7 Timing belt kit references
- 8 Camshaft references
- 9 Camkit references
- 10 Rocker arm references  
(required engine quantity in brackets)
- 11 Tappet & Thrust pad references  
(required engine quantity in brackets)
- 12 Valve references
- 13 Fitting position
- 14 Valve dimensions
- 15 Valve OE reference
- 16 Material code
- 17 Valve stem coating
- 18 Cotter design
- 19 Seat angle
- 20 Seat treatment
- 21 Tip treatment
- 22 Valve guide references
- 23 Valve guide shape
- 24 Valve guide dimensions











MATERIAL CODE	TYPE	HEAD	STEM	SUITABLE FOR
MB	Mono-Metal	Martensitic chrome-silicon alloy steel	n/a	Petrol & diesel inlet valves and for stems in bimetallic exhaust valves
MD	Mono-Metal	Austenitic chrome-manganese-nickel steel	n/a	Exhaust valves operating up to 750°C
ME	Bi-Metal	Austenitic chrome-manganese-nickel steel with added niobium, tungsten and nitrogen	MB	Heavy duty exhaust valves, operating up to 780°C
MF	Bi-Metal	Nimonic™, nickel based super alloy with added chromium, cobalt and titanium	MB	Exhaust valves; good mechanical strength, resistance to fatigue, erosion & corrosion. Operating up to 820°C
MG	Bi-Metal	MD	MB	Exhaust valves operating up to 750°C

FEATURE CODE	DESCRIPTION
cr	Chrome layer on valve stem
tu	Tuftrided/Nitrided valve
ss	Stellite welded seat
Y	Hardened valve seat
st	Stellite welded tip
H	Hardened valve tip

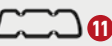
# HOW TO USE THIS CATALOGUE











## FIAT GROUP









<b>172</b> <sup>1</sup>	<b>80.50</b> <sup>2</sup>	<b>Petrol</b>			
159 A2.000 <sup>3</sup>	4 Cyl.	9.2:1	1372cc	57kW (78)PS	<sup>4</sup> TD9728 <sup>5</sup> 911
160 A1.000	4 Cyl.	9.2:1	1372cc	52-56kW (71-76)PS	TD1015 <sup>5</sup> 911
836 A4.000	4 Cyl.	9.2:1	1372cc	51kW (69)PS	TD893 <sup>5</sup> 912

 <sup>6</sup>	 <sup>7</sup>	 <sup>8</sup>	 <sup>9</sup>	 <sup>10</sup>	 <sup>11</sup>	 <sup>12</sup>	 <sup>13</sup>
BR620 Fibre Composite	DR620	GR620	HBS051 	JD146 JF150	JP049  (Cork) JN805 	HR363 	NA5187 30.00x52.00x7.00mm ACM



















BR620

- 1** Panel no.
- 2** Bore size
- 3** Engine detail
- 4** TecDoc / F-M engine no.
- 5** Corresponding bottom engine panel number
- 6** **CYLINDER HEAD GASKET**
  -  = Left
  -  = Right
  -  = Piston protrusion
  - 0.50mm = Thickness
  - 1 hole = Identification mark
- 7** **HEAD SET**
  -  = Without cylinder head gasket
  -  = Without seals
  -  = Without valve cover gasket
  -  = Without valve stem seals
- 8** **FULL SET**
  -  = Without cylinder head gasket
  -  = Without seals
  -  = Without valve cover gasket
  -  = Without valve stem seals

- 9** **HEADBOLT SET**
  -  Headbolt shape
  -  Male hex
  -  Female hex
  -  Male star
  -  Female star
  -  Male torx
  -  Female torx
  -  Hexagon Collar
  -  Female Splined (Ribe-CV)\*

\*Ribe-CV® is a registered trademark of Richard Bergner GmbH & Co.

- 10** **MANIFOLD GASKET**
  - Left = 
  - Right = 
  - Set = 
  - Inlet = 
  - Exhaust = 
  - Upper = 
  - Lower = 
- 11** **VALVE COVER GASKET**
  - Left = 
  - Right = 
  - Inlet = 
  - Exhaust = 
  - Set = 
- 12** **VALVE STEM SEAL**
  - Set = 
  - Inlet = 
  - Exhaust = 
- 13** **CAMSHAFT OIL SEALS**
  - Front = 
  - Rear = 

# HOW TO USE THIS CATALOGUE

EN



## FIAT GROUP

898 <sup>1</sup>	80.00 <sup>2</sup>	Petrol				
AR 00548 <sup>3</sup>	4 Cyl.	1779cc	83-97kW (113-132)PS	<sup>4</sup>	TD18	152 <sup>5</sup>
AR 01608	4 Cyl.	1779cc	87-89kW (118-121)PS		TD5340	154
AR 01608 X	4 Cyl.	1779cc	85kW (115)PS		TD33	155
AR 01678	4 Cyl.	1779cc	88-90kW (120-122)PS		TD38	154
AR 06168	4 Cyl.	1779cc	88kW (120)PS		TD54	157
AR 06202	4 Cyl.	1779cc	85-89kW (116-121)PS		TD55	157
AR 61102	4 Cyl.	9:1	1779cc		TD10149	157

<p>87-528500-00 STD</p> <p><sup>6</sup></p> <p>A 33.25 B- 13.35 D 80.10 Ø = 22x69</p>	<p>08-528500-00 STD</p> <p><sup>7</sup></p> <p>1.50 CR P 1.75 P 3.50 P</p>	<p>15-632600-00 WH [1]</p> <p>B 85.00 C 152.00 D 98.00 E 107.50</p> <p><sup>8</sup> <sup>9</sup></p>	<p>89-528500-00 87-528500-00 + 15-632600-00</p> <p><sup>11</sup></p>
---	--	--	--

<sup>10</sup>

<sup>12</sup>

[1] Includes seals [1] Inclut des joints [1] Comprende le guarnizioni [1] Incluye los sellos

BE/PL	4	49.988/49.998	53.695/53.708	23.440	1.838	0.021/0.069	BS	60010CP	71-4168/4 STD 0.25 0.50
MB/HL 1,3,5	3	59.960/59.973	63.657/63.676	25.530	1.837	0.020/0.067	BS	60011CP	H1030/5 STD 0.25 0.50
MB/HL 2,4	2	59.960/59.973	63.657/63.676	18.360	1.837	0.020/0.067	BS	60012CP	
TW/A	4	65.786/66.040	82.423/82.677		2.362		AL-LF	2777AF	A178/4 STD

- <sup>1</sup> Panel no.
- <sup>2</sup> Bore size
- <sup>3</sup> Engine detail
- <sup>4</sup> TecDoc / F-M engine no.
- <sup>5</sup> Corresponding top engine panel number
- <sup>6</sup> Piston reference
  - A = Compression height
  - B = Bowl depth / Crown height
  - BØ = Bowl diameter
  - C = Valve pocket depth
  - D = Length
  - RT = Alfin insert
  - KK = Oil cooling gallery
  - AK = Oil jet cut-out
  - HA = hard anodised coating on crown
  - NB = Bronze pin bush
  - TP = Trapezoidal Conrod
- <sup>7</sup> Ring set reference
  - Ring width
  - Ring design
  - Ring surface treatment
- <sup>8</sup> Liner reference
  - B = Outer diameter
  - C = Overall length
  - D = Flange diameter
  - E = Flange width
  - F = Firelip height
- <sup>9</sup> Liner type
  - D = Dry
  - WH = Wet Honed
  - DH = Dry Honed
- <sup>10</sup> Piston image and casting number (if applicable)
- <sup>11</sup> Kitset assembly reference
- <sup>12</sup> [ ] = Technical note



# HOW TO USE THIS CATALOGUE



EN

- 13** Bearing type and position  
BE/PL = Connecting rod (big end) bearing  
MB/HL = Main bearing  
TW/A = Thrust washer  
SE/PB = Piston pin (small end) bushing  
CB/NWB = Camshaft bushing  
BU = Other bushings
- 14** Set composition
- 15** Minimum and maximum standard journal diameter
- 16** Minimum and maximum housing bore diameter
- 17** Maximum bearing width
- 18** Maximum standard wall thickness
- 19** Oil clearance
- 20** Bearing material codes  
AL = Steel back aluminium.....Bi-/Trimetallic  
B = Brass  
BB = Steel back babbit.....Bimetallic  
BC = Steel back cast bronze – no overlay.....Bimetallic  
BS = Steel back sintered bronze – no overlay...Bi-/Trimetallic  
EC = Steel back bronze – electrocoated.....Trimetallic  
SP = Steel back bronze – Sputter.....Trimetallic  
IX = Steel back aluminium – Polymer  
-LF= Lead-free
- 21** Component reference
- 22** Glyco set reference and available undersizes  
H = Main bearing  
N = Camshaft bushing  
A = Thrust washer  
.../4 = Number of pairs (bearings) or pieces (washers / bushings) per set  
...H = Thrust (flange) bearing



<b>FIAT GROUP</b>					
<b>995</b>	<b>82.60</b>	<b>Diesel</b>			
149 B2.000	4 Cyl.	20:1	1697cc	42kW (57)PS	TD16864 <b>295</b>
<b>23</b>	<b>24</b>	<b>25</b>			
<b>EV684</b>	<b>JJ298</b> (Cork)  <b>JJ298</b>	<b>NB742</b> 30.00x43.00x3.00mm, ACM <b>NB732</b> 74.00x90.00x10.00mm, FPM			

- 23** **CONVERSION SET**  
▲ = Without cylinder head gasket  
■ = Without seals  
☒ = Without valve cover gasket  
● = Without valve stem seals

- 24** **SUMP GASKET**  
Set = **S**

- 25** **CRANKSHAFT SEAL**  
Front = **F**  
Rear = **R**

# SO BENUTZEN SIE DIESEN KATALOG

DE



## FIAT GROUP

172 <sup>1</sup>		80.50 <sup>2</sup>		Petrol			
159 A2.000 <sup>3</sup>	4 Cyl.	9.2:1	1372cc	57kW (78)PS		4 TD9728	911 <sup>5</sup>
160 A1.000	4 Cyl.	9.2:1	1372cc	52-56kW (71-76)PS		TD1015	911
836 A4.000	4 Cyl.	9.2:1	1372cc	51kW (69)PS		TD893	912

<b>TB305</b> 138x15	<b>TBK027</b> Component No:TB305;AE1008TP	<b>CAM719</b>			<b>FOL104 (x8) [8]</b>
[8] Mechanical	[8] Mécanique	[8] Meccanico			[8] Mecánico

<b>V91300</b> <sup>13</sup>	7609772	<sup>14</sup>	<sup>15</sup>	<b>MB</b> <sup>18</sup>	45°	<b>H</b>				<b>VAG92366</b> <sup>13</sup>	<sup>24</sup>	<sup>23</sup>
37.50 x 8.00 x 108.50	4315062			<b>MD</b> <sup>16</sup>	45°					46.50 x 8.00 x 14.10		
<b>V90071</b> <sup>13</sup>	4315062			<b>MD cr</b> <sup>17</sup>	45°							
30.99 x 8.00 x 109.09												
<b>V91713</b> <sup>13</sup>												
31.00 x 8.00 x 109.00												

- <sup>1</sup> Infotafel
- <sup>2</sup> Bohrung
- <sup>3</sup> Motordetails
- <sup>4</sup> TecDoc-Nr. / F-M Motornummer
- <sup>5</sup> Entsprechende Infotafel für Motorblock
- <sup>6</sup> Steuerriemen, Teilenummern  
Anzahl der Zähne x Riemenbreite
- <sup>7</sup> Steuerriemensätze, Teilenummern
- <sup>8</sup> Nockenwellen, Teilenummern
- <sup>9</sup> Nockenwellensätze, Teilenummern
- <sup>10</sup> Kipphebel, Teilenummern  
(erforderliche Anzahl pro Motor in Klammern)
- <sup>11</sup> Stößel und Druckstücke,  
Teilenummern  
(erforderliche Anzahl pro Motor in Klammern)
- <sup>12</sup> Ventile, Teilenummern
- <sup>13</sup> Einbauseite
- <sup>14</sup> Ventilabmessungen
- <sup>15</sup> Ventil-OE-Bezeichnung
- <sup>16</sup> Materialcode
- <sup>17</sup> Ventilschaftbeschichtung
- <sup>18</sup> Kegelstückkonstruktion
- <sup>19</sup> Sitzwinkel
- <sup>20</sup> Sitzbehandlung
- <sup>21</sup> Ventilenendenbehandlung
- <sup>22</sup> Ventilführungsbezeichnungen
- <sup>23</sup> Ventilführungsform
- <sup>24</sup> Ventilführungsabmessungen

MATERIALCODE	BAUART	KOPF	SCHAFT	PASSEND FÜR
MB	Monometall	Martensitischer Chrom-Silizium-Legierungsstahl	k. A.	Einlassventile (für Otto- und Dieselmotoren) und für Schäfte in bimetalischen Auslassventile
MD	Monometall	Austenitischer Chrom-Mangan-Nickel-Stahl	k. A.	Auslassventile, Einsatz bis max. 750 °C
ME	Bimetall	Austenitischer Chrom-Mangan-Nickel-Stahl mit Zusatz von Niobium, Wolfram und Stickstoff	MB	Hochleistungs-Auslassventile, Einsatz bis max. 780 °C
MF	Bimetall	Nimonic™, nickelbasierte Superlegierung mit Zusatz von Chrom, Cobalt und Titan	MB	Auslassventile; gute mechanische Festigkeit, Ermüdungsfestigkeit, Erosions- und Korrosionsbeständigkeit Einsatz bis max. 820 °C
MG	Bimetall	MD	MB	Auslassventile, Einsatz bis max. 750 °C





KURZZEICHEN AUSSTATTUNG	BESCHREIBUNG
cr	Chrombeschichteter Ventilschaft
tu	Tufride-behandelter/nitrierter Schaft
ss	Geschweißter Stellitventilsitz
Y	Gehärteter Ventilsitz
st	Geschweißte Stellitspitze
H	Gehärtete Ventilspitze















# SO BENUTZEN SIE DIESEN KATALOG













DE

















## FIAT GROUP

<b>172</b> 	<b>80.50</b> 	<b>Petrol</b>				
<b>159 A2.000</b> 	4 Cyl.	9.2:1	1372cc	57kW (78)PS	<b>4</b> TD9728	<b>911</b> 
<b>160 A1.000</b>	4 Cyl.	9.2:1	1372cc	52-56kW (71-76)PS	TD1015	<b>911</b>
<b>836 A4.000</b>	4 Cyl.	9.2:1	1372cc	51kW (69)PS	TD893	<b>912</b>

							
BR620 Fibre Composite	DR620	GR620	HBS051 	JD146  JF150	JP049  (Cork) JN805 	HR363 	NA5187 30.00x52.00x7.00mm ACM
							
BR620							

- 1** Infotafel
- 2** Bohrung
- 3** Motordetails
- 4** TecDoc-Nr. / F-M Motornummer
- 5** Entsprechende Infotafel für Motorblock
- 6** **ZYLINDERKOPFDICHTUNG**
  -  = Links
  -  = Rechts
  -  = Kolbenüberstand
  - 0,50 mm = Dicke
  - 1 Öffnung = Kennzeichnung
- 7** **ZYLINDERKOPFDICHTUNGSSATZ**
  -  = Ohne Zylinderkopfdichtung
  -  = Ohne Dichtringe
  -  = Ohne Ventildeckeldichtung
  -  = Ohne Ventilschaftdichtringe
- 8** **VOLLSTÄNDIGER SATZ**
  -  = Ohne Zylinderkopfdichtung
  -  = Ohne Dichtringe
  -  = Ohne Ventildeckeldichtung
  -  = Ohne Ventilschaftdichtringe

- 9** **ZYLINDERKOPFSCHRAUBENSATZ**
  -  Zylinderkopfschrauben-Form
  -  Außensechskant
  -  Innensechskant
  -  Außenvielzahn
  -  Innenvielzahn
  -  Außentorx
  -  Innentorx
  -  Sechskantbund
  -  Außensechskant-Keilzahn (Ribe-CV®)\*

- 10** **AUSPUFFKRÜMMERDICHTUNG**
  - Links = 
  - Rechts = 
  - Satz = 
  - Einlass = 
  - Auslass = 
  - Oben = 
  - Unten = 
- 11** **VENTILDECKELDICHTUNG**
  - Links = 
  - Rechts = 
  - Einlass = 
  - Auslass = 
  - Satz = 
- 12** **VENTILSCHAFTDICHTUNG**
  - Satz = 
  - Einlass = 
  - Auslass = 
- 13** **NOCKENWELLEN-ÖLDICHTUNGEN**
  - Vorn = 
  - Hinten = 

\*Ribe-CV® ist ein eingetragenes Warenzeichen der Richard Bergner GmbH & Co.

# SO BENUTZEN SIE DIESEN KATALOG

DE



## FIAT GROUP

898 <sup>1</sup>	80.00 <sup>2</sup>	Petrol				
AR 00548 <sup>3</sup>	4 Cyl.	1779cc	83-97kW (113-132)PS	<sup>4</sup>	TD18	152 <sup>5</sup>
AR 01608	4 Cyl.	1779cc	87-89kW (118-121)PS		TD5340	154
AR 01608 X	4 Cyl.	1779cc	85kW (115)PS		TD33	155
AR 01678	4 Cyl.	1779cc	88-90kW (120-122)PS		TD38	154
AR 06168	4 Cyl.	1779cc	88kW (120)PS		TD54	157
AR 06202	4 Cyl.	1779cc	85-89kW (116-121)PS		TD55	157
AR 61102	4 Cyl. 9:1	1779cc	88kW (120)PS		TD10149	157

<p><b>87-528500-00</b> STD <sup>6</sup></p> <p>A 33.25 B- 13.35 D 80.10 22x69</p>	<p><b>08-528500-00</b> STD <sup>7</sup></p> <p>1.50 CR P 1.75 P 3.50 P</p>	<p><b>15-632600-00 WH [1]</b> B 85.00 C 152.00 D 98.00 E 107.50</p>	<p><b>89-528500-00</b> <b>87-528500-00 +</b> <b>15-632600-00</b> <sup>11</sup></p>
---	--	---	--

<sup>12</sup>  
[1] Includes seals [1] Inclut des joints [1] Comprende le guarnizioni [1] Incluye los sellos

BE/PL	4	49.988/49.998	53.695/53.708	23.440	1.838	0.021/0.069	BS	60010CP	<b>71-4168/4</b> STD 0.25 0.50
MB/HL 1,3,5	3	59.960/59.973	63.657/63.676	25.530	1.837	0.020/0.067	BS	60011CP	<b>H1030/5</b> STD 0.25 0.50
MB/HL 2,4	2	59.960/59.973	63.657/63.676	18.360	1.837	0.020/0.067	BS	60012CP	
TW/A	4	65.786/66.040	82.423/82.677		2.362		AL-LF	2777AF	<b>A178/4</b> STD

- <sup>1</sup> Infotafel
- <sup>2</sup> Bohrung
- <sup>3</sup> Motordetails
- <sup>4</sup> TecDoc-Nr. / F-M Motornummer
- <sup>5</sup> Entsprechende Infotafel für Zylinderkopf
- <sup>6</sup> Kolben, Teilnummern
  - A = Kompressionshöhe
  - B = Muldentiefe/Bodenhöhe
  - BØ = Muldendurchmesser
  - C = Ventiltaschentiefe
  - D = Länge
  - RT = Alfin-Einsatz
  - KK = Ölkühlkanal
  - AK = Öldüsenausparung
  - HA = Hartanodisierter Kolbenboden
  - NB = Bolzenbuchse aus Bronze
  - TP = Trapezbleuel
- <sup>7</sup> Kolbenringsätze, Teilnummern
  - Ringhöhe
  - Ringbauart
  - Ring-Oberflächenbehandlung
- <sup>8</sup> Laufbuchsen, Teilnummern
  - B = Außendurchmesser
  - C = Gesamtlänge
  - D = Bunddurchmesser
  - E = Bundbreite
  - F = Feuersteghöhe
- <sup>9</sup> Laufbuchsentyp
  - D = trocken
  - WH = nass, gehont
  - DH = trocken, gehont
- <sup>10</sup> Kolbenabbildung und Kokille (falls zutreffend)
- <sup>11</sup> Artikelnummer Einbausatz
- <sup>12</sup> [ ] = Technischer Hinweis

# SO BENUTZEN SIE DIESEN KATALOG



DE

- 13 Gleitlager, Art und Position  
BE/PL = Pleuel(fuß)lager  
MB/HL = Hauptlager  
TW/A = Druckscheibe  
SE/PB = Pleuel(kopf)buchse  
CB/NWB = Nockenwellenbuchse  
BU = Andere Buchsen
- 14 Satzbestandteile
- 15 Min. und max. Standard-Zapfendurchmesser
- 16 Min. und max. Gehäusebohrungsdurchmesser
- 17 Max. Gleitlagerbreite
- 18 Max. Standardwandstärke
- 19 Ölspalt
- 20 Gleitlagermaterial-Abkürzungen  
AL = Stahlrücken Aluminium.....Bi-/Trimetall  
B = Messing  
BB = Stahlrücken Babbit.....Bimetall  
BC = Stahlrücken Gussbronze – ohne Auflage.....Bimetall  
BS = Stahlrücken Sinterbronze – ohne Auflage.....Bi-/Trimetall  
EC = Stahlrücken Bronze – galvanisiert.....Trimetall  
SP = Stahlrücken Bronze – Sputter.....Trimetall  
IX = Stahlrücken Aluminium – Polymer  
-LF= Bleifrei
- 21 Bauteile, Teilenummern
- 22 Glyco-Satz-Teilenummern und erhältliche Untergrößen  
H = Hauptlager  
N = Nockenwellenbuchse  
A = Druckscheibe  
.../4 = Anzahl Paare (Gleitlager) oder Stück (Scheiben/  
Buchsen) pro Satz  
...H = Axial(flansch)lager



<b>FIAT GROUP</b>					
<b>995</b>	<b>82.60</b>	<b>Diesel</b>			
149 B2.000	4 Cyl.	20:1	1697cc	42kW (57)PS	TD16864 <b>295</b>
<b>23</b>	<b>24</b>		<b>25</b>		
<b>EV684</b>	<b>JJ298</b> (Cork)  <b>JJ298</b>		<b>NB742</b> 30.00x43.00x8.00mm, ACM <b>NB732</b> 74.00x90.00x10.00mm, FPM		

- 23 **KURBELGEHÄUSESATZ**  
▲ = Ohne Zylinderkopfdichtung  
■ = Ohne Dichtringe  
☒ = Ohne Ventildeckeldichtung  
● = Ohne Ventilschaftdichtringe

- 24 **ÖLWANNENDICHTUNG**  
Satz =

- 25 **KURBELWELLEN-DICHTRING**  
Vorn =   
Hinten =

# COME SI UTILIZZA IL CATALOGO

IT



FIAT GROUP				
172 1	80.50 2	Petrol		
159 A2.000 3	4 Cyl.	9.2:1	1372cc	57kW (78)PS 4 TD9728 911 5
160 A1.000	4 Cyl.	9.2:1	1372cc	52-56kW (71-76)PS TD1015 911
836 A4.000	4 Cyl.	9.2:1	1372cc	51kW (69)PS TD893 912
6	7	8	9	10
TB305 138x15	TBK027 Component No:TB305;AE1008TP	CAM719		FOL104 (x8) [8]
[8] Mechanical	[8] Mécanique	[8] Meccanico	[8] Mecánico	
12	OE	MAT.	19	20
V91300  13	7609772	18	45°	H
37.50 x 8.00 x 108.50 14	15	MB	19	20
V90071  13	4315062	MD cr	45°	21
30.99 x 8.00 x 109.09		MD cr	45°	
V91713  13	4315062	16		
31.00 x 8.00 x 109.00		17		
			22	23
			VAG92366  13	46.50 x 8.00 x 14.10 24





- 1 N. Pannello
- 2 Alesaggio
- 3 Dati motore
- 4 TecDoc / F-M N. motore
- 5 Numero pannello corrispondente alla parte bassa motore
- 6 Riferimenti cinghia di distribuzione N.di denti x larghezza cinghia
- 7 Riferimenti kit cinghia di distribuzione
- 8 Riferimenti albero a camme
- 9 Riferimenti kit albero a camme
- 10 Riferimenti bilanciere (tra parentesi quantità richiesta per motore)
- 11 Riferimenti punterie e piattelli (tra parentesi quantità richiesta per motore)
- 12 Riferimenti valvola
- 13 Posizione di montaggio
- 14 Dimensioni valvola
- 15 Riferimento OE valvola
- 16 Codice materiale
- 17 Rivestimento stelo valvola
- 18 Design coppiglia
- 19 Angolo sede
- 20 Trattamento sede
- 21 Trattamento puntale
- 22 Riferimenti guidaavvalvola
- 23 Forma guidaavvalvola
- 24 Dimensioni guidaavvalvola











CODICE MATERIALE	TIPO	TESTA	STELO	ADATTO A
MB	Monometallo	Acciaio martensitico cromo-silicio	n/d	Valvole di aspirazione diesel e benzina e per steli in valvole di aspirazione bimetalliche
MD	Monometallo	Acciaio nichel-manganese-cromo Austenitico	n/d	Valvole di scarico per temperature fino a 750°C
ME	Bimetallo	Acciaio nichel-manganese-cromo Austenitico con niobio, tungsteno e azoto in lega	MB	Valvole di scarico per applicazioni pesanti per temperature fino a 780°C
MF	Bimetallo	Nimonic™, lega super a base di nichel con cromo, cobalto e titanio in lega	MB	Valvole di scarico; buona resistenza meccanica, resistenza a fatica, erosione e corrosione. Per temperature fino a 820°C
MG	Bimetallo	MD	MB	Valvole di scarico per temperature fino a 750°C

CODICE CARATTERISTICHE	DESCRIZIONE
cr	Strato di cromo sullo stelo di valvola
tu	Valvola Carbotritura
ss	Sede saldata in stellite
Y	Sede valvola rinforzata
st	Puntale saldato in Stellite
H	Puntale valvola rinforzato

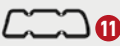
# COME SI UTILIZZA IL CATALOGO

## FIAT GROUP

<b>172</b> 	<b>80.50</b> 	<b>Petrol</b>				
<b>159 A2.000</b> 	4 Cyl.	9.2:1	1372cc	57kW (78)PS	<b>4</b> <b>TD9728</b>	<b>911</b> <b>5</b>
<b>160 A1.000</b>	4 Cyl.	9.2:1	1372cc	52-56kW (71-76)PS	<b>TD1015</b>	<b>911</b>
<b>836 A4.000</b>	4 Cyl.	9.2:1	1372cc	51kW (69)PS	<b>TD893</b>	<b>912</b>

							
BR620 Fibre Composite	DR620	GR620	HBS051 	JD146 JF150	JP049  (Cork) JN805 	HR363 	NA5187 30.00x52.00x7.00mm ACM



BR620

**1** N. Pannello

**2** Alesaggio

**3** Dati motore

**4** TecDoc / F-M N. motore

**5** Numero pannello corrispondente alla parte superiore del motore

**6 GUARNIZIONE TESTA CILINDRO**

 = Sinistra

 = Destra

 = Sporgenza pistone

0.50mm = spessore

1 foro = segno di identificazione

**7 KIT TESTA**

 = Senza guarnizione testa cilindro

 = Senza guarnizioni

 = Senza guarnizione coperchio valvola

 = Senza guarnizioni stelo valvola

**8 KIT COMPLETO**

 = Senza guarnizione testa cilindro

 = Senza guarnizioni

 = Senza guarnizione coperchio valvola

 = Senza guarnizioni stelo valvola

**9 KIT VITI TESTA**

 Forma viti testa



 Maschio esagonale



 Femmina esagonale



 Maschio a stella



 Femmina a stella



 Torx maschio



 Torx femmina



 Collare esagonale





 Femmina scanalata (Ribe-CV®)\*

\*Ribe-CV® è un marchio registrato di Richard Bergner GmbH & Co.

**10 GUARNIZIONE COLLETTORE**

Sinistra = 

Destra = 

Kit = 

Aspirazione = 

Scarico = 

Superiore = 

Inferiore = 

**11 GUARNIZIONE COPERCHIO VALVOLA**

Sinistra = 

Destra = 

Aspirazione = 

Scarico = 

Kit = 

**12 GUARNIZIONE STELO VALVOLA**

Kit = 

Aspirazione = 

Scarico = 

**13 PARAOLIO ALBERO A CAMME**

Anteriore = 

Posteriore = 

# COME SI UTILIZZA IL CATALOGO

IT



## FIAT GROUP

898 <sup>1</sup>	80.00 <sup>2</sup>	Petrol				
AR 00548 <sup>3</sup>	4 Cyl.	1779cc	83-97kW (113-132)PS	<sup>4</sup>	TD18	152 <sup>5</sup>
AR 01608	4 Cyl.	1779cc	87-89kW (118-121)PS		TD5340	154
AR 01608 X	4 Cyl.	1779cc	85kW (115)PS		TD33	155
AR 01678	4 Cyl.	1779cc	88-90kW (120-122)PS		TD38	154
AR 06168	4 Cyl.	1779cc	88kW (120)PS		TD54	157
AR 06202	4 Cyl.	1779cc	85-89kW (116-121)PS		TD55	157
AR 61102	4 Cyl.	9:1	1779cc		TD10149	157

<p>87-528500-00 STD</p> <p><sup>6</sup></p> <p>A 33.25 B- 13.35 D 80.10 22x69</p>	<p>08-528500-00 STD</p> <p><sup>7</sup></p> <p>1.50 CR P 1.75 P 3.50 P</p>	<p>15-632600-00 WH [1]</p> <p>B 85.00 C 152.00 D 98.00 E 107.50</p> <p><sup>8</sup> <sup>9</sup></p>	<p>89-528500-00 87-528500-00 + 15-632600-00</p> <p><sup>11</sup></p>
<sup>12</sup>			

[1] Includes seals [1] Inclut des joints [1] Comprende le guarnizioni [1] Incluye los sellos

BE/PL	4	49.988/49.998	53.695/53.708	23.440	1.838	0.021/0.069	BS	60010CP	71-4168/4 STD 0.25 0.50
MB/HL 1,3,5	3	59.960/59.973	63.657/63.676	25.530	1.837	0.020/0.067	BS	60011CP	H1030/5 STD 0.25 0.50
MB/HL 2,4	2	59.960/59.973	63.657/63.676	18.360	1.837	0.020/0.067	BS	60012CP	
TW/A	4	65.786/66.040	82.423/82.677		2.362		AL-LF	2777AF	A178/4 STD

- <sup>1</sup> N. Pannello
- <sup>2</sup> Alesaggio
- <sup>3</sup> Dati motore
- <sup>4</sup> TecDoc / F-M N. motore
- <sup>5</sup> Numero pannello corrispondente alla parte superiore del motore
- <sup>6</sup> Codice Pistone
  - A = altezza di compressione
  - B = profondità camera di combustione /sporgenza testa
  - Bø = diametro camera di combustione
  - C = profondità sede valvola
  - D = Lunghezza
  - RT = inserto Alfin
  - KK = galleria di raffreddamento olio
  - AK = nicchia getto olio
  - HA = rivestimento anodizzato sul cielo
  - NB = boccola foro spinotto
  - TP = biella trapezoidale
- <sup>7</sup> Codice set segmenti
  - Larghezza segmento
  - Forma segmento
  - Treatmento superficiale segmento
- <sup>8</sup> Codice canna
  - B = diametro esterno
  - C = lunghezza totale
  - D = diametro flangia
  - E = larghezza flangia
  - F = altezza parafiamma fiamma
- <sup>9</sup> Tipo canna
  - D = A Secco
  - WH = Riportata in Umido
  - DH = Riportata a Secco
- <sup>10</sup> Immagine pistone e numero di fusione (dove applicabile)
- <sup>11</sup> Codice gruppo kit
- <sup>12</sup> [ ] = Note tecniche



# COME SI UTILIZZA IL CATALOGO



IT

- 13** Tipo e posizione cuscinetto  
 BE/PL = Cuscinetto (testa di) biella  
 MB/HL = Cuscinetto di banco  
 TW/A = Spallamenti  
 SE/PB = Boccola spinotto pistone (piede di biella)  
 CB/NWB = Boccola albero a camme  
 BU = Altre boccole
- 14** Composizione set
- 15** Diametro perno di banco standard minimo e massimo
- 16** Diametro alesaggio sede minimo e massimo
- 17** Larghezza massima del cuscinetto
- 18** Spessore parete standard massimo
- 19** Passaggio olio
- 20** Codici materiale cuscinetti  
 AL = Alluminio su supporto in acciaio.....Bi-/Trimetallico  
 B = Ottone  
 BB = Lega antiattrito fondo acciaio.....Bimetallico  
 BC = Bronzo su supporto in acciaio –  
 no rivestimento.....Bimetallico  
 BS = Bronzo sinterizzato con supporto in acciaio –  
 no rivestimento.....Bi-/Trimetallico  
 EC = Bronzo su supporto in acciaio –  
 elettrodeposto .....Trimetallico

- SP = Bronzo su supporto in acciaio –  
 processo sputter.....Trimetallico
- IX = Alluminio su supporto in acciaio – Polimerico  
 -LF= Senza piombo
- 24** Codice componente
- 22** Codice kit Glyco e misure (sottodimensionate) disponibili  
 H = Cuscinetto di banco  
 N = Boccola albero a camme  
 A = Spallamento  
 .../4 = Numero coppie (di cuscinetti) o pezzi (spallamenti/  
 boccole) per ciascun set  
 ...H = Cuscinetto di spinta (flangiato)



FIAT GROUP			
995	82.60	Diesel	
149 B2.000	4 Cyl.	20:1	1697cc
			42kW (57)PS
			TD16864 295
23	24	25	
EV684	JJ298 (Cork)  JJ298	NB742  30.00x43.00x3.00mm, ACM NB732  74.00x90.00x10.00mm, FPM	

- 23** **SERIE COMPLEMENTARE**  
 ▲ = Senza guarnizione testa cilindro  
 ■ = Senza guarnizioni  
 ☒ = Senza guarnizione coperchio  
 valvola  
 ● = Senza guarnizioni stelo valvola

- 24** **GUARNIZIONE COPPA OLIO**  
 Kit =

- 25** **GUARNIZIONE  
 ALBERO MOTORE**  
 Anteriore =   
 Posteriore =

# COMMENT SE SERVIR DE CE CATALOGUE

FR



## FIAT GROUP

<b>172</b>		<b>80.50</b>		<b>Petrol</b>			
<b>159 A2.000</b>	4 Cyl.	9.2:1	1372cc	<b>57kW (78)PS</b>	<b>4</b> <b>TD9728</b>	<b>911</b>	<b>5</b>
<b>160 A1.000</b>	4 Cyl.	9.2:1	1372cc	<b>52-56kW (71-76)PS</b>	<b>TD1015</b>	<b>911</b>	
<b>836 A4.000</b>	4 Cyl.	9.2:1	1372cc	<b>51kW (69)PS</b>	<b>TD893</b>	<b>912</b>	

<b>TB305</b> 138x15	<b>TBK027</b> Component No:TB305;AE1008TP	<b>CAM719</b>			<b>FOL104 (x8)</b> [8]
[8] Mechanical	[8] Mécanique	[8] Meccanico			[8] Mecánico

<b>B x C x D</b>	<b>OE</b>	<b>MAT.</b>	<b>45°</b>	<b>H</b>	<b>E x F x G</b>							
<b>V91300</b>	7609772				<b>VAG92366</b>							
37.50 x 8.00 x 108.50					46.50 x 8.00 x 14.10							
<b>V90071</b>	4315062											
30.99 x 8.00 x 109.09												
<b>V91713</b>	4315062											
31.00 x 8.00 x 109.00												

- 1** N° d'encadré
- 2** Taille d'alésage
- 3** Détail du moteur
- 4** Numéro moteur F-M / Numéro TecDoc
- 5** N° d'encadré bas moteur correspondant
- 6** Références de courroie de distribution  
Nbre de dents x largeur courroie
- 7** Références de kits de courroie de distribution
- 8** Références d'arbres à came
- 9** Références de kit d'arbres à came
- 10** Références de culbuteur  
(quantité moteur exigée entre parenthèses)
- 11** Références patin de butée et poussoir à tige (quantité moteur exigée entre parenthèses)
- 12** Référence de soupape
- 13** Position de montage
- 14** Dimensions de soupape
- 15** Référence OE de soupape
- 16** Code du matériau
- 17** Revêtement de la tige de soupape
- 18** Modèle à goupille
- 19** Angle du siège
- 20** Traitement du siège
- 21** Traitement de pointe
- 22** Référence du guide de soupape
- 23** Forme du guide de soupape
- 24** Dimensions du guide de soupape













CODE DU MATÉRIAU	TYPE	TÊTE	TIGE	VALABLE POUR
MB	Mono-métallique	Acier d'alliage silicone-chrome martensitique	S/O	Soupapes d'admission essence et diesel, et pour tiges des soupapes d'échappement bimétallique
MD	Mono-métallique	Acier nickel - manganèse - chrome austénitique	S/O	Soupapes d'échappement fonctionnant jusqu'à 750 °C
ME	Bimétallique	Acier nickel - manganèse - chrome austénitique avec niobium, tungstène et azote ajouté.	MB	Soupapes d'échappement haut de gamme fonctionnant jusqu'à 780 °C
MF	Bimétallique	Nimonic™, super alliage à base de nickel avec ajout de chrome, cobalt et titane.	MB	Soupapes d'échappement ; bonne résistance mécanique, à la fatigue, à l'érosion et à la corrosion. Fonctionnant jusqu'à 820 °C
MG	Bimétallique	MD	MB	Soupapes d'échappement fonctionnant jusqu'à 750 °C

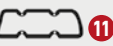









CODE CARACTÉRISTIQUE	DESCRIPTION
cr	Couche de chrome sur tige de soupape
tu	Soupape Nitrurée
ss	Siège soudé Stellite
Y	Siège de soupape durci
st	Pointe soudée Stellite
H	Pointe de soupape durcie

# COMMENT SE SERVIR DE CE CATALOGUE

## FIAT GROUP

<b>172</b> <sup>1</sup>	<sup>2</sup> <b>80.50</b>	<b>Petrol</b>			
<b>159 A2.000</b> <sup>3</sup>	4 Cyl.	9.2:1	1372cc	57kW (78)PS	<sup>4</sup> TD9728 <sup>5</sup> <b>911</b>
<b>160 A1.000</b>	4 Cyl.	9.2:1	1372cc	52-56kW (71-76)PS	TD1015 <b>911</b>
<b>836 A4.000</b>	4 Cyl.	9.2:1	1372cc	51kW (69)PS	TD893 <b>912</b>

 <sup>6</sup>	 <sup>7</sup>	 <sup>8</sup>	 <sup>9</sup>	 <sup>10</sup>	 <sup>11</sup>	 <sup>12</sup>	 <sup>13</sup>
BR620 Fibre Composite	DR620	GR620	HBS051 	JD146 JF150	JP049  (Cork) JN805 	HR363 	NA5187 30.00x52.00x7.00mm ACM
							
BR620							

- 1** N° d'encadré
- 2** Taille d'alésage
- 3** Détail du moteur
- 4** Numéro moteur F-M / Numéro TecDoc
- 5** N° d'encadré bas moteur correspondant
- 6 JOINT DE CULASSE**
  -  = Gauche
  -  = Droite
  -  = Saillie piston
  - 0,50 mm = épaisseur
  - 1 trou = marque d'identification
- 7 ENSEMBLE CULASSE**
  -  = Sans joint de culasse
  -  = Sans bagues d'étanchéité
  -  = Sans joint de couvre culasse
  -  = Sans joints de tige de soupape
- 8 ENSEMBLE COMPLET**
  -  = Sans joint de culasse
  -  = Sans bagues d'étanchéité
  -  = Sans joint de couvre culasse
  -  = Sans joints de tige de soupape

**9 JEU VIS DE CULASSE**



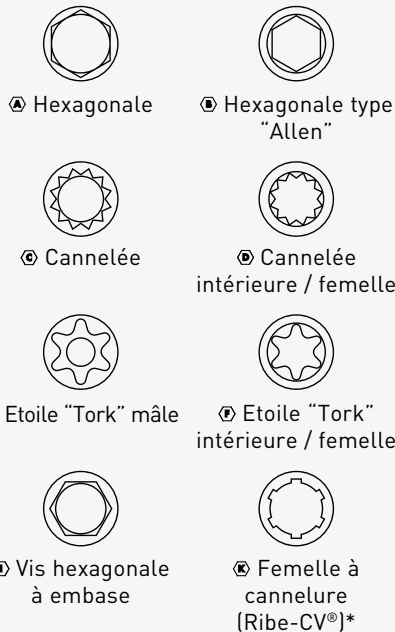

 Forme de vis de culasse





**10 JOINT COLLECTEUR**

- Gauche = 
- Droite = 
- Jeu = 
- Admission = 
- Échappement = 
- Supérieur = 
- Inférieur = 



**11 JOINT DE COUVRE CULASSE**

- Gauche = 
- Droite = 
- Admission = 
- Échappement = 
- Jeu = 

**12 JOINT DE TIGE DE SOUPE**

- Jeu = 
- Admission = 
- Échappement = 

**13 BAGUES D'ÉTANCHÉITÉ D'ARBRE À CAMES**

- Avant = 
- Arrière = 

\*Ribe-CV® est une marque enregistrée de Richard Bergner GmbH & Co.

# COMMENT SE SERVIR DE CE CATALOGUE

FR



FIAT GROUP

898 <sup>1</sup>	80.00 <sup>2</sup>	Petrol				
AR 00548 <sup>3</sup>	4 Cyl.	1779cc	83-97kW (113-132)PS	<sup>4</sup>	TD18	152 <sup>5</sup>
AR 01608	4 Cyl.	1779cc	87-89kW (118-121)PS		TD5340	154
AR 01608 X	4 Cyl.	1779cc	85kW (115)PS		TD33	155
AR 01678	4 Cyl.	1779cc	88-90kW (120-122)PS		TD38	154
AR 06168	4 Cyl.	1779cc	88kW (120)PS		TD54	157
AR 06202	4 Cyl.	1779cc	85-89kW (116-121)PS		TD55	157
AR 61102	4 Cyl. 9:1	1779cc	88kW (120)PS		TD10149	157

<p>87-528500-00 STD</p> <p><sup>6</sup></p> <p>A 33.25 B- 13.35 D 80.10 Bø 22x69</p>	<p>10</p>	<p>08-528500-00 STD</p> <p><sup>7</sup></p> <p>1.50 CR P 1.75 P 3.50 P</p>	<p>15-632600-00 WH [1]</p> <p>B 85.00 C 152.00 D 98.00 E 107.50</p> <p><sup>8</sup> <sup>9</sup></p>	<p>89-528500-00 87-528500-00 + 15-632600-00</p> <p><sup>11</sup></p>
--	-----------	--	--	--

<sup>12</sup>  
[1] Includes seals [1] Inclut des joints [1] Comprende le guarnizioni [1] Incluye los sellos

BE/PL	4	49.988/49.998	53.695/53.708	23.440	1.838	0.021/0.069	BS	60010CP	71-4168/4 STD 0.25 0.50
MB/HL 1,3,5	3	59.960/59.973	63.657/63.676	25.530	1.837	0.020/0.067	BS	60011CP	H1030/5 STD 0.25 0.50
MB/HL 2,4	2	59.960/59.973	63.657/63.676	18.360	1.837	0.020/0.067	BS	60012CP	
TW/A	4	65.786/66.040	82.423/82.677		2.362		AL-LF	2777AF	A178/4 STD

- <sup>1</sup> N° d'encadré
- <sup>2</sup> Taille d'alésage
- <sup>3</sup> Détail du moteur
- <sup>4</sup> Numéro moteur F-M / Numéro TecDoc
- <sup>5</sup> N° d'encadré haut moteur correspondant
- <sup>6</sup> Référence du piston
  - A = Hauteur d'axe
  - B = Profondeur de la chambre / Hauteur du bossage
  - Bø = Diamètre de la chambre du piston
  - C = Passage de la soupape
  - D = Longueur totale
  - RT = Piston à porte-segments
  - KK = Canal de refroidissement
  - AK = Dégagement pour gicleur d'huile de refroidissement
  - HA = Tête endurcie par oxydation
  - NB = Bague en bronze
  - TP = Bielle trapézoïdale
- <sup>7</sup> Référence du jeu de segments
  - Largeur de segment
  - Schémas des segments
  - Traitement de surface
- <sup>8</sup> Référence de chemise
  - B = Diamètre extérieur
  - C = Longueur totale
  - D = Diamètre bride
  - E = Largeur de collerette
  - F = Hauteur de parefeu
- <sup>9</sup> Type chemise
  - D = Sèche
  - WH = Traitée au sable humide
  - DH = Traitée au sable sec
- <sup>10</sup> Image piston et numéro coquille (le cas échéant)
- <sup>11</sup> Référence du kit d'assemblage
- <sup>12</sup> [ ] = Note technique

# COMMENT SE SERVIR DE CE CATALOGUE



FR

- 13** Type et emplacement du coussinet  
 BE/PL = Coussinet de bielle (tête de bielle)  
 MB/HL = Coussinet de palier  
 TW/A = Flasque de butée  
 SE/PB = Bague de bielle  
 CB/NWB = Bague d'arbre à cames  
 BU = Autres bagues
- 14** Composition du jeu de coussinet
- 15** Diamètre minimum et maximum de maneton standard
- 16** Diamètre minimum et maximum d'alésage du logement
- 17** Largeur maximale de coussinet
- 18** Épaisseur maximale de standard
- 19** Jeu de fonctionnement
- 20** Codification des matériaux de coussinets  
 AL = Aluminium sur support acier..... Bi/trimétallique  
 B = Laiton  
 BB = Etain-plomb sur support acier..... Bimétallique  
 BC = Bronze coulé sur support acier - sans revêtement..... Bimétallique  
 BS = Bronze fritté sur support acier - sans revêtement..... Bi/trimétallique  
 EC = Bronze sur support acier - électrolytique..... Trimétallique
- SP = Bronze sur support acier - pulvérisé..... Trimétallique  
 IX = Aluminium sur support acier - polymère  
 -LF= Sans plomb
- 21** Référence du composant
- 22** Référence du jeu Glyco et cotes réparation disponibles  
 H = Coussinet de palier  
 N = Bague d'arbre à cames  
 A = Flasque de butée  
 .../4 = Paires (coussinets) ou pièces (flasques de butées/ bagues) par jeu  
 ...H = Roulement de butée (à bride)



FIAT GROUP			
<b>995</b>	82.60	<b>Diesel</b>	
149 B2.000	4 Cyl.	20:1	1697cc 42kW (57)PS TD16864 <b>295</b>
<b>23</b>	<b>24</b>	<b>25</b>	
EV684	JJ298 (Cork)  JJ298	NB742  30.00x43.00x8.00mm, ACM NB732  74.00x90.00x10.00mm, FPM	

**23** **POCHETTE COMPLÉMENT**

- ▲ = Sans joint de culasse
- = Sans bagues d'étanchéité
- ☒ = Sans joint de couvre culasse
- = Sans joints de tige de soupape

**24** **JOINT DE CARTER D'HUILE**

Pochette =

**25** **BAGUE D'ÉTANCHÉITÉ DE VILEBREQUIN**

Avant =

Arrière =

# CÓMO UTILIZAR ESTE CATÁLOGO







ES











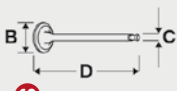

## FIAT GROUP

<b>172</b> <sup>1</sup>		<b>80.50</b> <sup>2</sup>		<b>Petrol</b>			
<b>159 A2.000</b> <sup>3</sup>	4 Cyl.	9.2:1	1372cc	<b>57kW (78)PS</b>	<b>4</b>	<b>TD9728</b>	<b>911</b> <sup>5</sup>
<b>160 A1.000</b>	4 Cyl.	9.2:1	1372cc	<b>52-56kW (71-76)PS</b>		<b>TD1015</b>	<b>911</b>
<b>836 A4.000</b>	4 Cyl.	9.2:1	1372cc	<b>51kW (69)PS</b>		<b>TD893</b>	<b>912</b>

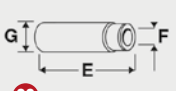
 <b>6</b>	 <b>7</b>	 <b>8</b>	 <b>9</b>	 <b>10</b>	 <b>11</b>
<b>TB305</b> 138x15	<b>TBK027</b> Component No:TB305;AE1008TP	<b>CAM719</b>			<b>FOL104 (x8) [8]</b>
[8] Mechanical	[8] Mécanique	[8] Meccanico		[8] Mecánico	

 <b>12</b> B x C x D	OE	 <b>18</b>	 <b>19</b>	 <b>21</b>	 <b>22</b> E x F x G
<b>V91300</b>  <b>13</b> 37.50 x 8.00 x 108.50 <b>14</b>	7609772 <b>15</b>	<b>MB</b>	45° <b>19</b>	<b>H</b> <b>21</b>	<b>VAG92366</b>  <b>13</b> 46.50 x 8.00 x 14.10 <b>24</b>
<b>V90071</b>  <b>13</b> 30.99 x 8.00 x 109.09	4315062	<b>MD cr</b>	45° <b>19</b>		 <b>23</b>
<b>V91713</b>  <b>13</b> 31.00 x 8.00 x 109.00	4315062	<b>MD cr</b> <b>16</b> <b>17</b>	45° <b>19</b>		

- 1** N.º panel
- 2** Diámetro del cilindro
- 3** Datos del motor
- 4** Número motor F-M / TecDoc
- 5** Número de panel del motor correspondiente
- 6** Referencias de las correas de distribución  
N.º de dientes x anchura de la correa
- 7** Referencias del kit de correas de distribución
- 8** Referencias del árbol de levas
- 9** Referencias del kit de levas
- 10** Referencias de balancín (cantidad necesaria para el motor, entre paréntesis)
- 11** Referencias de pastillas de empuje y taqués (cantidad necesaria para el motor, entre paréntesis)
- 12** Referencias de válvula
- 13** Posición de montaje
- 14** Dimensiones de válvula
- 15** Referencia de equipo original de la válvula
- 16** Referencias
- 17** Revestimiento del vástago de la válvula
- 18** Diseño de la chaveta
- 19** Ángulo del asiento
- 20** Tratamiento del asiento
- 21** Tratamiento de la punta del vástago
- 22** Referencias de la guía de válvula
- 23** Forma de la guía de válvula
- 24** Dimensiones de la guía de válvula

REFERENCIA	TIPO	CULATA	VÁSTAGO	ADECUADO PARA
MB	Monometálico	Aleación de acero al cromo-silicio martensítico	N/D	Válvulas de admisión de gasolina y diésel para vástagos de válvulas de escape bimetalicas
MD	Monometálico	Acero austenítico al cromo-manganeso-níquel	N/D	Válvulas de escape que soportan hasta 750 °C
ME	Bimetálico	Acero austenítico al cromo-manganeso-níquel con niobio, tungsteno y nitrógeno	MB	Válvulas de escape para vehículos pesados, rango de temperatura de trabajo de hasta 780 °C
MF	Bimetálico	Nimonic™, superaleación al níquel con cromo, cobalto y titanio	MB	Válvulas de escape de buena resistencia mecánica, con resistencia a la fatiga, la erosión y la corrosión; Rango de temperatura de hasta 820 °C
MG	Bimetálico	MD	MB	Válvulas de escape con rango de temperatura hasta 750 °C





CÓDIGO DE CARACTERÍSTICA	DESCRIPCIÓN
cr	Capa de cromo en el vástago de la válvula
tu	Válvula nitrurada / nitrocarburizada
ss	Asiento Stellite soldado
Y	Asiento de válvula endurecido
st	Punta Stellite soldada
H	Punta de válvula endurecida

# CÓMO UTILIZAR ESTE CATÁLOGO

## FIAT GROUP











<b>172</b> <b>1</b>	<b>80.50</b> <b>2</b>	<b>Petrol</b>			
<b>159 A2.000</b> <b>3</b>	4 Cyl.	9.2:1	1372cc	57kW (78)PS	<b>4</b> TD9728 <b>911</b> <b>5</b>
<b>160 A1.000</b>	4 Cyl.	9.2:1	1372cc	52-56kW (71-76)PS	TD1015 <b>911</b>
<b>836 A4.000</b>	4 Cyl.	9.2:1	1372cc	51kW (69)PS	TD893 <b>912</b>



BR620 Fibre Composite	DR620	GR620	HBS051 	JD146  JF150	JP049  (Cork) JN805 	HR363 	NA5187 30.00x52.00x7.00mm ACM
-----------------------	-------	-------	--	--	--	---	----------------------------------



BR620

- 1** N.º panel
- 2** Diámetro del cilindro
- 3** Datos del motor
- 4** Número motor F-M / TecDoc
- 5** Número de panel de la parte inferior del motor correspondiente
- 6 JUNTA DE CULATA**
  -  = Izquierda
  -  = Derecha
  -  = Protrusión del pistón
  - 0.50 mm = Grosor
  - 1 orificio = Marca de identificación
- 7 CONJUNTO DE CULATA**
  -  = Sin junta de culata
  -  = Sin juntas
  -  = Sin junta de cubierta de la válvula
  -  = Sin juntas del vástago de la válvula
- 8 CONJUNTO COMPLETO**
  -  = Sin junta de culata
  -  = Sin juntas
  -  = Sin junta de cubierta de la válvula
  -  = Sin juntas del vástago de la válvula

### **9 CONJUNTO DE TORNILLOS DE CULATA**

-  Forma de tornillos



 Macho hex.



 Hembra hex.



 Macho estrella



 Hembra estrella



 Macho torx



 Hembra torx









 Hexágono con anillo







 Hembra acanalada (Ribe-CV®)\*

\*Ribe-CV® es una marca comercial registrada de Richard Bergner GmbH & Co.



### **10 JUNTA DEL COLECTOR**

- Izquierda = 
- Derecha = 
- Conjunto = 
- Admisión = 
- Escape = 
- Parte superior = 
- Parte inferior = 



### **11 JUNTA DE CUBIERTA DE LA VÁLVULA**

- Izquierda = 
- Derecha = 
- Admisión = 
- Escape = 
- Conjunto = 

### **12 JUNTA DEL VÁSTAGO DE LA VÁLVULA**

- Conjunto = 
- Admisión = 
- Escape = 

### **13 RETENES DE ACEITE DEL ÁRBOL DE LEVAS**

- Parte delantera = 
- Parte trasera = 

# CÓMO UTILIZAR ESTE CATÁLOGO

ES



FIAT GROUP

898 <sup>1</sup>	80.00 <sup>2</sup>	Petrol				
AR 00548 <sup>3</sup>	4 Cyl.	1779cc	83-97kW (113-132)PS	<sup>4</sup>	TD18	152 <sup>5</sup>
AR 01608	4 Cyl.	1779cc	87-89kW (118-121)PS		TD5340	154
AR 01608 X	4 Cyl.	1779cc	85kW (115)PS		TD33	155
AR 01678	4 Cyl.	1779cc	88-90kW (120-122)PS		TD38	154
AR 06168	4 Cyl.	1779cc	88kW (120)PS		TD54	157
AR 06202	4 Cyl.	1779cc	85-89kW (116-121)PS		TD55	157
AR 61102	4 Cyl. 9:1	1779cc	88kW (120)PS		TD10149	157

<p>87-528500-00 STD</p> <p><sup>6</sup></p> <p>A 33.25 B- 13.35 D 80.10 22x69</p>	<p>08-528500-00 STD</p> <p><sup>7</sup></p> <p>1.50 CR P 1.75 P 3.50 P</p>	<p>15-632600-00 WH [1]</p> <p>B 85.00 C 152.00 D 98.00 E 107.50</p>	<p>89-528500-00 87-528500-00 + 15-632600-00</p> <p><sup>11</sup></p>
---	--	---	--

<sup>12</sup>  
[1] Includes seals [1] Inclut des joints [1] Comprende le guarnizioni [1] Incluye los sellos

BE/PL	4	49.988/49.998	53.695/53.708	23.440	1.838	0.021/0.069	BS	60010CP	71-4168/4 STD 0.25 0.50
MB/HL 1,3,5	3	59.960/59.973	63.657/63.676	25.530	1.837	0.020/0.067	BS	60011CP	H1030/5 STD 0.25 0.50
MB/HL 2,4	2	59.960/59.973	63.657/63.676	18.360	1.837	0.020/0.067	BS	60012CP	
TW/A	4	65.786/66.040	82.423/82.677		2.362		AL-LF	2777AF	A178/4 STD

- <sup>1</sup> N.º panel
- <sup>2</sup> Diámetro del cilindro
- <sup>3</sup> Datos del motor
- <sup>4</sup> Número motor F-M / TecDoc
- <sup>5</sup> Número de panel de la parte superior del motor correspondiente
- <sup>6</sup> Referencia del pistón
  - A = Altura de compresión
  - B = Profundidad de la cabeza / Altura de la corona
  - Bø = Diámetro de la cabeza
  - C = Profundidad asiento de válvula
  - D = Longitud
  - RT = Inserción alfin
  - KK = Conductos de refrigeración de aceite
  - AK = Corte del inyector de aceite
  - HA = Revestimiento duro anodizado en la corona
  - NB = Perno de bronce
  - TP = Cabeza de biela trapezoidal
- <sup>7</sup> Referencia del conjunto de segmentos
  - Anchura del segmento
  - Diseño del segmento
  - Tratamiento de la superficie del segmento
- <sup>8</sup> Referencia de la camisa
  - B = Diámetro exterior
  - C = Longitud general
  - D = Diámetro de la brida
  - E = Anchura de la brida
  - F = Altura cortafuego
- <sup>9</sup> Tipo de camisa
  - D = Seca
  - WH = Pulida húmeda
  - DH = Pulida seca
- <sup>10</sup> Número de moldeado e imagen del pistón (si procede)
- <sup>11</sup> Referencia del conjunto del kit
- <sup>12</sup> [ ] = Nota técnica



# CÓMO UTILIZAR ESTE CATÁLOGO









ES

- 13** Tipo de cojinete y posición  
 BE/PL = Cojinete de biela  
 MB/HL = Cojinete principal  
 TW/A = Arandela de empuje  
 SE/PB = Casquillo del bulón  
 CB/NWB = Casquillo del árbol de levas  
 BU = Otros casquillos
- 14** Composición del conjunto
- 15** Diámetro de la muñequilla estándar mínimo y máximo
- 16** Diámetro mínimo y máximo de la carcasa
- 17** Anchura máxima del cojinete
- 18** Grosor estándar máximo de la pared
- 19** Paso de aceite
- 20** Códigos del material del cojinete  
 AL = Aluminio con acero.....Bi/trimetálico  
 B = Latón  
 BB = Antifricción con acero.....Bimetálico  
 BC = Bronce fundido con acero -  
 sin superposición.....Bimetálico  
 BS = Bronce aglomerado con acero -  
 sin superposición.....Bi/trimetálico  
 EC = Bronce con acero -  
 revestimiento electrónico.....Trimetálico

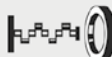

- SP = Bronce con acero -  
 pulverización catódica.....Trimetálico  
 IX = Aluminio con acero - polímero  
 -LF= Sin plomo
- 21** Referencia del componente
- 22** Referencia del conjunto de Glyco y dimensiones disponibles por debajo de la estándar  
 H = Cojinete de bancada  
 N = Casquillo del árbol de levas  
 A = Arandela de empuje  
 .../4 = Número de pares (cojinetes) o piezas (arandelas/casquillos) por conjunto  
 ...H = Cojinete (brida) de empuje



FIAT GROUP					
995	82.60	Diesel			
149 B2.000	4 Cyl.	20:1	1697cc	42kW (57)PS	TD16864 295
 <b>23</b>	 <b>24</b>	 <b>25</b>			
EV684	JJ298 (Cork)  JJ298	NB742  30.00x43.00x3.00mm, ACM NB732  74.00x90.00x10.00mm, FPM			

- 23**  **JUEGO DE PARTE BAJA**  
 ▲ = Sin junta de culata  
 ■ = Sin retenes  
 ☒ = Sin junta de tapa de válvulas  
 ● = Sin retenes de válvula

- 24** **JUNTA DEL CÁRTER**  
 Conjunto = 

- 25** **RETÉN DEL CIGÜEÑAL**  
 Delantero =   
 Trasero = 

# JAK UŻYWAĆ TEGO KATALOGU

PL



## FIAT GROUP

172 <sup>1</sup>

80.50 <sup>2</sup>

Petrol



159 A2.000 <sup>3</sup>	4 Cyl.	9.2:1	1372cc	57kW (78)PS	<sup>4</sup> TD9728	<sup>5</sup> 911
160 A1.000	4 Cyl.	9.2:1	1372cc	52-56kW (71-76)PS	TD1015	911
836 A4.000	4 Cyl.	9.2:1	1372cc	51kW (69)PS	TD893	912

<sup>6</sup>	<sup>7</sup>	<sup>8</sup>	<sup>9</sup>	<sup>10</sup>	<sup>11</sup>
<b>TB305</b> 138x15	<b>TBK027</b> Component No:TB305;AE1008TP	<b>CAM719</b>			<b>FOL104</b> (x8) [8]
[8] Mechanical	[8] Mécanique	[8] Meccanica			[8] Mecánico

<sup>12</sup> B x C x D	OE	MAT.	<sup>18</sup>	<sup>19</sup>	<sup>21</sup>	<sup>22</sup> E x F x G
<b>V91300</b> <sup>13</sup> 37.50 x 8.00 x 108.50 <sup>14</sup>	7609772 <sup>15</sup>	<sup>16</sup> MB	<sup>17</sup> 45°	<sup>18</sup> 45°	<sup>19</sup> H	<b>VAG92366</b> <sup>20</sup> <sup>21</sup> <sup>23</sup> 46.50 x 8.00 x 14.10 <sup>24</sup>
<b>V90071</b> <sup>13</sup> 30.99 x 8.00 x 109.09	4315062	<sup>16</sup> MD cr	<sup>17</sup> 45°	<sup>18</sup> 45°	<sup>19</sup>	
<b>V91713</b> <sup>13</sup> 31.00 x 8.00 x 109.00	4315062	<sup>16</sup> MD cr <sup>17</sup>	<sup>17</sup> 45°	<sup>18</sup>	<sup>19</sup>	



- <sup>1</sup> Numer
- <sup>2</sup> Średnica cylindra
- <sup>3</sup> Dane silnika
- <sup>4</sup> Nr silnika F-M/TecDoc
- <sup>5</sup> Odpowiadający numer dołu silnika
- <sup>6</sup> Referencje paska rozrządu  
Liczba zębów x szerokość paska
- <sup>7</sup> Referencje zestawu paska rozrządu
- <sup>8</sup> Referencje wałka rozrządu
- <sup>9</sup> Referencje zestawu krzywek rozrządu
- <sup>10</sup> Referencje dźwigni zaworowych (wymagane ilości na silnik w nawiasach)
- <sup>11</sup> Referencje popychaczy i ptytek oporowych (wymagane ilości na silnik w nawiasach)
- <sup>12</sup> Referencje zaworów
- <sup>13</sup> Pozycja montażu
- <sup>14</sup> Wymiary zaworu
- <sup>15</sup> Referencje OE zaworu
- <sup>16</sup> Kod materiału
- <sup>17</sup> Powłoka trzpienia zaworu
- <sup>18</sup> Typ klina poprzecznego
- <sup>19</sup> Kąt gniazda
- <sup>20</sup> Obróbka gniazda
- <sup>21</sup> Obróbka końcówki
- <sup>22</sup> Referencje prowadnicy zaworu
- <sup>23</sup> Kształt prowadnicy zaworu
- <sup>24</sup> Wymiary prowadnicy zaworu











KOD MATERIAŁU	TYP	GŁOWICA	TRZPIEŃ	ZASTOSOWANIE
MB	Monometal	Martenzytyczna stal chromowokorzeźmowa	nd	Zawory dolotowe w silnikach benzynowych i wysokoprężnych oraz do trzpieni w bimetalicznych zaworach wylotowych
MD	Monometal	Austenityczna stal chromowo-niklowo-manganowa	nd	Zawory wydechowe pracujące w temperaturze do 750°C
ME	Bimetal	Austenityczna stal chromowo-niklowo-manganowa z dodatkiem niobu, wolframu i azotu	MB	Bardzo trwałe zawory wydechowe, pracujące w temperaturze do 780°C
MF	Bimetal	Nimonic™, superstop na bazie niklu z dodatkiem chromu, kobaltu i tytanu	MB	Zawory wydechowe, dobra wytrzymałość mechaniczna, odporność na zmęczenie, erozję i korozję. Praca w temperaturze do 820°C
MG	Bimetal	MD	MB	Zawory wydechowe pracujące w temperaturze do 750°C

KOD CECHY	OPIS
cr	Warstwa chromu na trzpieniu zaworu
tu	Zawór węgloazotowany (w procesie Tufftride)/azotowany
ss	Spawane staliowe gniazdo
Y	Utwardzone gniazdo zaworu
st	Spawana końcówka staliowa
H	Hartowana końcówka zaworu

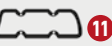
# JAK UŻYWAĆ TEGO KATALOGU











## FIAT GROUP

<b>172</b> <sup>1</sup>	 <b>80.50</b> <sup>2</sup>	<b>Petrol</b>				
<b>159 A2.000</b> <sup>3</sup>	4 Cyl.	9.2:1	1372cc	57kW (78)PS	<b>4</b> TD9728	<b>911</b> <sup>5</sup>
<b>160 A1.000</b>	4 Cyl.	9.2:1	1372cc	52-56kW (71-76)PS	TD1015	<b>911</b>
<b>836 A4.000</b>	4 Cyl.	9.2:1	1372cc	51kW (69)PS	TD893	<b>912</b>

 <b>6</b>	 <b>7</b>	 <b>8</b>	 <b>9</b>	 <b>10</b>	 <b>11</b>	 <b>12</b>	 <b>13</b>
BR620 Fibre Composite	DR620	GR620	HBS051 	JD146 JF150	JP049  (Cork) JN805 	HR363 	NA5187 30.00x52.00x7.00mm ACM



BR620

- 1** Numer
- 2** Średnica cylindra
- 3** Dane silnika
- 4** Nr silnika F-M/TecDoc
- 5** Odpowiadający numer dotu silnika
- 6** **USZCZELKA POD GŁOWICĘ**
  -  = Lewa
  -  = Prawa
  -  = Występ tłoka
  - 0,50 mm = grubość
  - 1 otwór = oznaczenie identyfikacyjne
- 7** **ZESTAW GŁOWICY**
  -  = Bez uszczelki głowicy cylindra
  -  = Bez uszczelnień
  -  = Bez uszczelki pokrywy zaworów
  -  = Bez uszczelniaczy zaworowych
- 8** **PEŁNY ZESTAW**
  -  = Bez uszczelki głowicy cylindra
  -  = Bez uszczelnień
  -  = Bez uszczelki pokrywy zaworów
  -  = Bez uszczelniaczy zaworowych

### **9** ZESTAW ŚRUB DO GŁOWICY

-  Kształt śruby do głowicy

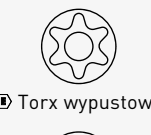





\* Ribe-CV® jest zastrzeżonym znakiem handlowym firmy Richard Bergner GmbH & Co.

### **10** USZCZELKA KOLEKTORA

- Lewa = 
- Prawa = 
- Zestaw = 
- Dolotowe = 
- Wydechowe = 
- Górne = 
- Dolne = 



### **11** USZCZELKA POKRYWY ZAWORÓW

- Lewa = 
- Prawa = 
- Dolotowe = 
- Wydechowe = 
- Zestaw = 

### **12** USZCZELNIACZ ZAWORU

- Zestaw = 
- Dolotowe = 
- Wydechowe = 

### **13** USZCZELNIENIA OLEJOWE WAŁKA ROZRZĄDU

- Przód = 
- Tył = 

# JAK UŻYWAĆ TEGO KATALOGU

PL



FIAT GROUP

898 <sup>1</sup>	80.00 <sup>2</sup>	Petrol				
AR 00548 <sup>3</sup>	4 Cyl.	1779cc	83-97kW (113-132)PS	<sup>4</sup>	TD18	152 <sup>5</sup>
AR 01608	4 Cyl.	1779cc	87-89kW (118-121)PS		TD5340	154
AR 01608 X	4 Cyl.	1779cc	85kW (115)PS		TD33	155
AR 01678	4 Cyl.	1779cc	88-90kW (120-122)PS		TD38	154
AR 06168	4 Cyl.	1779cc	88kW (120)PS		TD54	157
AR 06202	4 Cyl.	1779cc	85-89kW (116-121)PS		TD55	157
AR 61102	4 Cyl.	9:1	1779cc	88kW (120)PS	TD10149	157

<p>87-528500-00 STD</p> <p><sup>6</sup></p> <p>A 33.25 B- 13.35 D 80.10 Bø 22x69</p>	<p>08-528500-00 STD</p> <p><sup>7</sup></p> <p>1.50 CR P 1.75 P 3.50 P</p>	<p>15-632600-00 WH [1]</p> <p>B 85.00 C 152.00 D 98.00 E 107.50</p> <p><sup>8</sup> <sup>9</sup></p>	<p>89-528500-00 87-528500-00 + 15-632600-00</p> <p><sup>11</sup></p>
--	--	--	--

<sup>12</sup> [1] Includes seals [1] Inclut des joints [1] Comprende le guarnizioni [1] Incluye los sellos

<sup>13</sup>	<sup>14</sup>	<sup>15</sup>	<sup>16</sup>	<sup>17</sup>	<sup>18</sup>	<sup>19</sup>	<sup>20</sup>	<sup>21</sup>	<sup>22</sup>
BE/PL	4	49.988/49.998	53.695/53.708	23.440	1.838	0.021/0.069	BS	60010CP	71-4168/4 STD 0.25 0.50
MB/HL 1,3,5	3	59.960/59.973	63.657/63.676	25.530	1.837	0.020/0.067	BS	60011CP	H1030/5 STD 0.25 0.50
MB/HL 2,4	2	59.960/59.973	63.657/63.676	18.360	1.837	0.020/0.067	BS	60012CP	
TW/A	4	65.786/66.040	82.423/82.677		2.362		AL-LF	2777AF	A178/4 STD

- <sup>1</sup> Numer
- <sup>2</sup> Średnica cylindra
- <sup>3</sup> Dane silnika
- <sup>4</sup> Nr silnika F-M/TecDoc
- <sup>5</sup> Odpowiadający numer góry silnika
- <sup>6</sup> Dane tłoka
  - A = Wysokość kompresji
  - B = Głębokość czaszy/Wysokość korony
  - Bø = Średnica czaszy
  - C = Głębokość kieszeni zaworu
  - D = Długość
  - RT = Wkładka alfinowa
  - KK = Kanat chłodzenia oleju
  - AK = Wycięcie głowicy olejowej
  - HA = Twarda powłoka anodowana na koronie
  - NB = Tuleja sworznia z brązu
  - TP = Korbwódt trapezowy
- <sup>7</sup> Referencja zestawu pierścieni
  - Szerokość pierścienia
  - Typ pierścienia
  - Obróbka powierzchni pierścienia
- <sup>8</sup> Referencja tulei
  - B = Średnica zewnętrzna
  - C = Długość catkowita
  - D = Średnica kotnierza
  - E = Szerokość kotnierza
  - F = Wysokość krawędzi termicznej
- <sup>9</sup> Typ tulei
  - D = Sucha
  - WH = Honowana na mokro
  - DH = Honowana na sucho
- <sup>10</sup> Obraz tłoka i numer odlewu (jeśli dotyczy)
- <sup>11</sup> Nr referencyjny zestawu
- <sup>12</sup> [ ] = Uwaga techniczna

# JAK UŻYWAĆ TEGO KATALOGU



PL

- 13** Typ i pozycja łożyska  
BE/PL = Łożysko stopy korbowodu  
MB/HL = Łożysko główne  
TW/A = Podkładka oporowa  
SE/PB = Panewka sworznia korbowodu  
CB/NWB = Panewka wałka rozrządu  
BU = Inne panewki
- 14** Skład zestawu
- 15** Minimalna i maksymalna standardowa średnica czopu
- 16** Minimalna i maksymalna średnica otworu obudowy
- 17** Maksymalna szerokość łożyska
- 18** Maksymalna standardowa grubość ścianki
- 19** Szczelina olejowa
- 20** Kody materiału łożyska  
AL = Stal z aluminium.....Bi-/trimetaliczne  
B = Mosiądz  
BB = Stal z babbitem.....Bimetaliczne  
BC = Stal z odlewem z brązu – bez pokrycia...Bimetaliczne  
BS = Stal z brązem spiekany –  
bez pokrycia.....Bi-/trimetaliczne  
EC = Stal z brązem – powlekanie galwaniczne...Trimetallic  
SP = Stal z brązem – Sputer.....Trimetallic  
IX = Stal z aluminium - polimer  
-LF= Bezotowiove
- 21** Referencje składników
- 22** Referencje zestawu Glyco i dostępne podwymiary  
H = Łożysko główne  
N = Panewka wałka rozrządu  
A = Podkładka oporowa  
.../4 = Liczba par (łożysk) lub elementów (podkładek/  
panewek) na zestaw  
...H = Łożysko oporowe (kotnierzowe)



<b>FIAT GROUP</b>			
<b>995</b>	<b>82.60</b>	<b>Diesel</b>	
149 B2.000	4 Cyl.	20:1	1697cc
		42kW (57)PS	TD16864 <b>295</b>
<b>23</b>	<b>24</b>	<b>25</b>	
EV684	JJ298 (Cork)  JJ298	NB742  30.00x43.00x8.00mm, ACM NB732  74.00x90.00x10.00mm, FPM	

- 23** **ZESTAW USZCZELEK – DÓŁ SILNIKA**  
▲ = Bez uszczelki podgłowicowej  
■ = Bez uszczelnień  
☒ = Bez uszczelki pokrywy zaworów  
● = Bez uszczelnień trzonka zaworu

- 24** **USZCZELKA MISKI OLEJOWEJ**  
Komplett =

- 25** **USZCZELNIENIE WAŁU KORBOWEGO**  
Przedni =   
Tylny =

# КАК ПОЛЬЗОВАТЬСЯ КАТАЛОГОМ

RU



## FIAT GROUP

<b>172</b> 1		<b>80.50</b> 2		<b>Petrol</b>			
<b>159 A2.000</b> 3	4 Cyl.	9.2:1	1372cc	<b>57kW (78)PS</b>	<b>4</b> <b>TD9728</b>	<b>911</b> <b>5</b>	
<b>160 A1.000</b>	4 Cyl.	9.2:1	1372cc	<b>52-56kW (71-76)PS</b>	<b>TD1015</b>	<b>911</b>	
<b>836 A4.000</b>	4 Cyl.	9.2:1	1372cc	<b>51kW (69)PS</b>	<b>TD893</b>	<b>912</b>	
6	7	8	9	10	11		
<b>TB305</b> 138x15	<b>TBK027</b> Component No:TB305;AE1008TP	<b>CAM719</b>			<b>FOL104 (x8) [8]</b>		
[8] Mécanique		[8] Mécánica		[8] Meccanico		[8] Mecánico	
12 <b>B x C x D</b> OE    MAT.				22 <b>E x F x G</b>			
<b>V91300</b> 13	7609772	18	45°	21	<b>VAG92366</b> 13	19	20
<b>37.50 x 8.00 x 108.50</b> 14	<b>15</b>	16	45°	17	<b>46.50 x 8.00 x 14.10</b> 24	17	17
<b>V90071</b> 13	4315062	16	45°				
<b>30.99 x 8.00 x 109.09</b>							
<b>V91713</b> 13	4315062		45°				
<b>31.00 x 8.00 x 109.00</b>							

- 1 № секции
- 2 Диаметр цилиндра
- 3 Информация о двигателе
- 4 TecDoc / FM номер двигателя
- 5 Соответствующий номер информационной секции для нижней части двигателя
- 6 Номер ремня привода газораспределительного механизма Кол-во зубцов x ширина ремня
- 7 Номер комплекта ремня привода газораспределительного механизма
- 8 Номер распределительного вала
- 9 Номер комплекта распределительного вала
- 10 Номер клапанного коромысла (в скобках - требуемое количество на двигатель)
- 11 Номер толкателя клапана и упорной шайбы (в скобках - требуемое количество на двигатель)
- 12 Номер клапана
- 13 Положение установки
- 14 Размеры клапана
- 15 Оригинальный номер клапана
- 16 Код материала
- 17 Покрытие штока клапана
- 18 Конструкция сухаря клапана
- 19 Угол седла
- 20 Обработка седла
- 21 Обработка конца штока клапана
- 22 Номер направляющей втулки клапана
- 23 Форма направляющей втулки клапана
- 24 Размеры направляющей втулки клапана

КОД МАТЕРИАЛА	ТИП	ГОЛОВКА	ШТОК	ПОДХОДИТ ДЛЯ	ИДЕНТИФИЦИРУЮЩИЙ КОД	ОПИСАНИЕ
MB	Монометаллический	Мартенситная хромо-кремнистая сталь	нет	Впускные клапаны бензиновых и дизельных двигателей, штоки в биметаллических выпускных клапанах	cr	Хромовое покрытие штока клапана
MD	Монометаллический	Аустенитная хромо-марганцево-никелевая сталь	нет	Выпускные клапаны, функционирующие при температуре до 750°C	tu	Клапан, обработанный газовым нитрированием / азотированием
ME	Биметаллический	Аустенитная хромо-марганцево-никелевая сталь с добавлением ниобия, вольфрама и азота	MB	Выпускные клапаны для двигателей высокой мощности, функционирующие при температуре до 780°C	ss	Стеллитовое седло
MF	Биметаллический	Nimonic™, жаропрочный сплав на основе никеля с добавлением хрома, кобальта и титана	MB	Выпускные клапаны; высокая механическая прочность, сопротивление усталости, эрозии и коррозии. Функционирование при температуре до 820°C	y	Закаленное седло клапана
MG	Биметаллический	MD	MB	Выпускные клапаны, функционирующие при температуре до 750°C	st	Стеллитовый наконечник
					H	Закаленный наконечник клапана

## FIAT GROUP

<b>172</b> <sup>1</sup>	<b>80.50</b> <sup>2</sup>	<b>Petrol</b>			
<b>159 A2.000</b> <sup>3</sup>	4 Cyl.	9.2:1	1372cc	57kW (78)PS	<b>4</b> TD9728 <b>911</b> <b>5</b>
<b>160 A1.000</b>	4 Cyl.	9.2:1	1372cc	52-56kW (71-76)PS	TD1015 <b>911</b>
<b>836 A4.000</b>	4 Cyl.	9.2:1	1372cc	51kW (69)PS	TD893 <b>912</b>

BR620 Fibre Composite	DR620	GR620	HBS051 <sup>⊗</sup>	JD146 JF150	JP049 <sup>⊗</sup> (Cork) JN805 <sup>⊗</sup>	HR363 <sup>⊗</sup>	NA5187 30.00x52.00x7.00mm ACM
BR620							

- 1** № секции
- 2** Диаметр цилиндра
- 3** Информация о двигателе
- 4** ТесДос / FM номер двигателя
- 5** Соответствующий номер информационной секции для нижней части двигателя
- 6** **ПРОКЛАДКА ГОЛОВКИ БЛОКА ЦИЛИНДРОВ**
  - = Левый
  - = Правый
  - = Выступ поршня
  - 0,50 мм = толщина
  - 1 отверстие = идентификационная метка
- 7** **КОМПЛЕКТ ГОЛОВКИ БЛОКА ЦИЛИНДРОВ**
  - = Без прокладки головки блока цилиндров
  - = Без сальников
  - = Без прокладки крышки клапанного механизма
  - = Без сальников клапанов
- 8** **ПОЛНЫЙ КОМПЛЕКТ**
  - = Без прокладки головки блока цилиндров
  - = Без сальников
  - = Без прокладки крышки клапанного механизма
  - = Без сальников клапанов

- 9** **КОМПЛЕКТ БОЛТОВ ГОЛОВКИ БЛОКА ЦИЛИНДРОВ**
  - Форма болта головки
 

<input checked="" type="checkbox"/> Шестигранный с наружной резьбой	<input checked="" type="checkbox"/> Шестигранный с внутренней резьбой
<input checked="" type="checkbox"/> Наружная головка-звездочка	<input checked="" type="checkbox"/> Внутренняя головка-звездочка
<input checked="" type="checkbox"/> Наружная головка TORX	<input checked="" type="checkbox"/> Внутренняя головка TORX
<input checked="" type="checkbox"/> Шестигранная головка с цилиндрическим буртом	<input checked="" type="checkbox"/> Головка с шлицевым углублением [Ribe-CV®]*

\*Ribe-CV® является зарегистрированной торговой маркой Richard Bergner GmbH & Co.

- 10** **ПРОКЛАДКА КОЛЛЕКТОРА**
  - Левый =
  - Правый =
  - Комплект =
  - Впуск =
  - Выпуск =
  - Верхний =
  - Нижний =
- 11** **ПРОКЛАДКА КРЫШКИ КЛАПАННОГО МЕХАНИЗМА**
  - Левый =
  - Правый =
  - Впуск =
  - Выпуск =
  - Комплект =
- 12** **САЛЬНИКИ КЛАПАНОВ**
  - Комплект =
  - Впуск =
  - Выпуск =
- 13** **САЛЬНИКИ РАСПРЕДЕЛИТЕЛЬНОГО ВАЛА**
  - Передний =
  - Задний =

# КАК ПОЛЬЗОВАТЬСЯ КАТАЛОГОМ

RU



## FIAT GROUP

898 1	80.00 2	Petrol				
AR 00548 3	4 Cyl.	1779cc	83-97kW (113-132)PS	4	TD18	152 5
AR 01608	4 Cyl.	1779cc	87-89kW (118-121)PS		TD5340	154
AR 01608 X	4 Cyl.	1779cc	85kW (115)PS		TD33	155
AR 01678	4 Cyl.	1779cc	88-90kW (120-122)PS		TD38	154
AR 06168	4 Cyl.	1779cc	88kW (120)PS		TD54	157
AR 06202	4 Cyl.	1779cc	85-89kW (116-121)PS		TD55	157
AR 61102	4 Cyl.	9:1	1779cc		TD10149	157

<p>87-528500-00 STD</p> <p>6</p> <p>A 33.25 B- 13.35 D 80.10 22x69</p>	<p>08-528500-00 STD</p> <p>7</p> <p>1.50 CR P 1.75 P 3.50 P</p>	<p>15-632600-00 WH [1]</p> <p>8 9</p> <p>B 85.00 C 152.00 D 98.00 E 107.50</p>	<p>89-528500-00 87-528500-00 + 15-632600-00</p> <p>11</p>
--	---	--	---

12 [1] Includes seals [1] Inclut des joints [1] Comprende le guarnizioni [1] Incluye los sellos

<p>BE/PL 4 49.988/49.998</p>	<p>MB/HL 1,3,5 3 59.960/59.973</p>	<p>MB/HL 2,4 2 59.960/59.973</p>	<p>TW/A 4 65.786/66.040</p>	<p>53.695/53.708</p>	<p>23.440 1.838</p>	<p>0.021/0.069</p>	<p>BS 60010CP</p>	<p>60011CP</p>	<p>71-4168/4 STD 0.25 0.50 H1030/5 STD 0.25 0.50 A178/4 STD</p>
------------------------------	------------------------------------	----------------------------------	-----------------------------	----------------------	---------------------	--------------------	-------------------	----------------	---

- 1 № секции
- 2 Диаметр цилиндра
- 3 Информация о двигателе
- 4 TecDoc / FM номер двигателя
- 5 Соответствующий номер информационной секции для верхней части двигателя
- 6 Артикул и спецификация поршня
  - A = высота сжатия
  - B = глубина выемки / высота головки
  - BØ = диаметр выемки
  - C = глубина выемки под клапан
  - D = длина
  - RT = с усилителем канавки верхнего поршневого кольца Alfin
  - KK = с каналом масляного охлаждения
  - AK = с пазом/фаской для масляной форсунки
  - HA = головка с твердым анодированным покрытием
  - NB = с бронзовой втулкой поршневого пальца
  - TP = трапециевидный шатун
- 7 Информация о комплекте колец
  - Ширина кольца
  - Конструкция кольца
  - Обработка поверхности кольца
- 8 Информация о гильзе
  - B = внешний диаметр
  - C = общая длина
  - D = диаметр фланца
  - E = ширина фланца
  - F = высота огнезащитного уплотнения
- 9 Тип гильзы
  - D = "сухая"
  - WH = "мокрая" с хонинговкой
  - DH = "сухая" с хонинговкой
- 10 Изображение поршня и номер отливки (если есть)
- 11 Артикул комплекта
- 12 [ ] = Техническое



# КАК ПОЛЬЗОВАТЬСЯ КАТАЛОГОМ



RU

- 13** Тип подшипника скольжения и его положение  
BE/PL = Шатунный вкладыш (большая головка шатуна)  
MB/HL = Коренной вкладыш  
TW/A = Упорная шайба  
SE/PB = Втулка поршневого пальца (малая головка шатуна)  
CB/NWB = Втулка распределительного вала  
BU = Другие втулки
- 14** Состав комплекта
- 15** Диаметр шейки вала (стандартный): приведены размеры минимального и максимального диаметра шейки вала
- 16** Диаметр постели подшипника: приведены размеры минимального и максимального диаметра постели подшипника
- 17** Максимальная ширина подшипника
- 18** Максимальное значение стандартной толщины стенки
- 19** Масляный зазор
- 20** Коды материала подшипников скольжения  
AL = Алюминий на стальной подложке..... Би-/триметаллический  
B = Латунь  
BB = Баббит на стальной подложке..... Биметаллический  
BC = Литая бронза на стальной подложке – без покрытия..... Биметаллический  
BS = Спеченная бронза на стальной подложке – без покрытия..... Би-/триметаллический  
EC = Бронза на стальной подложке - покрытие методом электроосаждения..... Триметаллический  
SP = Бронза на стальной подложке со спаттерным напылением..... Триметаллический  
IX = Алюминий на стальной подложке – с полимерным покрытием  
-LF= Не содержит свинец
- 21** Номер детали
- 22** Номер комплекта Glyco и доступные ремонтные размеры  
H = Коренной вкладыш  
N = Втулка распределительного вала  
A = Упорная шайба  
.../4 = Количество пар (подшипников скольжения) или штук (шайб/втулок) в комплекте  
...H = Упорный (фланцевый) подшипник скольжения



FIAT GROUP			
995	82.60	Diesel	
149 B2.000	4 Cyl.	20:1	1697cc
		42kW (57)PS	TD16864 295
23	24	25	
EV684	JJ298 (Cork) JJ298	NB742  30.00x43.00x8.00mm, ACM NB732  74.00x90.00x10.00mm, FPM	

















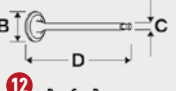



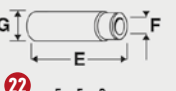







- 23** **КОМПЛЕКТ БЛОКА ЦИЛИНДРОВ**  
▲ Без прокладки головки блока цилиндров  
■ Без сальников  
☒ Без прокладки крышки клапанного механизма  
● Без сальников клапанов
- 24** **ПРОКЛАДКА ПОДДОНА КАРТЕРА**  
Комплект =
- 25** **САЛЬНИК КОЛЕНВАЛА**  
Передние = F  
Задние = R

# كيفية استخدام هذا الكتالوج

AR



## FIAT GROUP

172 1		80.50 2		Petrol			
159 A2.000 3	4 Cyl.	9.2:1	1372cc	57kW (78)PS	4 TD9728	911 5	
160 A1.000	4 Cyl.	9.2:1	1372cc	52-56kW (71-76)PS	TD1015	911	
836 A4.000	4 Cyl.	9.2:1	1372cc	51kW (69)PS	TD893	912	
 6	 7	 8	 9	 10	 11		
<b>TB305</b> 138x15	<b>TBK027</b> Component No:TB305;AE1008TP	<b>CAM719</b>			<b>FOL104 (x8) [8]</b>		
[8] Mechanical		[8] Mécanique		[8] Meccanico		[8] Mecánico	
 12	 13	 14	 15	 16	 17		
<b>V91300</b>  13	7609772	 14	 15	<b>VA692366</b>  13	 17		
37.50 x 8.00 x 108.50  14	 15	 16	 17	46.50 x 8.00 x 14.10  14	 17		
<b>V90071</b>  13	4315062	 16	 17				
30.99 x 8.00 x 109.09		 16	 17				
<b>V91713</b>  13	4315062						
31.00 x 8.00 x 109.00							

- 17 تغطية ساق الصمام
- 18 تصميم الإسفين
- 19 زاوية المقعد
- 20 معالجة المقعد
- 21 معالجة الرأس
- 22 مرجع موجه الصمام
- 23 شكل موجه الصمام
- 24 أبعاد موجه الصمام

- 9 مراجع طاقم الكامات
- 10 مراجع ذراع مترجحة
- (حجم المحرك المطلوب في الدعامات)
- 11 مراجعة مخدة الصمام والغمازة
- (حجم المحرك المطلوب في الدعامات)
- 12 مراجع الصمام
- 13 وضع التثبيت
- 14 أبعاد الصمام
- 15 مرجع صمام المعدات الأصلية
- 16 كود المادة

- 1 رقم اللوحة
- 2 حجم التجوي
- 3 تفاصيل المحك
- 4 مستند المواصفات / رقم محرك FM
- 5 رقم لوحة المحركة السفلية المطاب
- 6 مراجع حزام التوقي
- عدد الأسنان x عرض الحزام
- 7 مراجع طاقم حزام التوقي
- 8 مراجع عمود الكامات

الوصف	كود الخاصية
طبقة الكروم في ساق الصمام	cr
صمامات التتوجين / الطف البركاني	tu
مقعد ملحوم بالإستيللايت	ss
مقعد صمام مقوى	Y
رأس ملحوم بالإستيللايت	st
رأس صمام مقوى	H

كود المواد	نوع	الرأس	الساق	مناسب من أجل
MB	المعدن الأحادي	سبيكة فولاذية من الكروم مارتنيسي	غير مطبق	صمامات سحب الديزل والبنزول وسيقان صمامات العادم ثنائية المعدن
MD	المعدن الأحادي	صمامات سحب الديزل والبنزول وسيقان صمامات العادم ثنائية المعدن	غير مطبق	صمامات العادم التي تعمل عند درجة حرارة 750 درجة مئوية
ME	المعدن الثنائي	سبيكة فولاذية من الكروم والنيكل والمنجنيز الأوستيني مع النيوبيوم والتنجستن والتيتانيوم المضاف	MB	صمامات عوادم الخدمة الشاقة التي تعمل عند درجة حرارة 780 درجة مئوية
MF	المعدن الثنائي	هي سبيكة ممتازة من Nimonic <sup>TM</sup> سبيكة النيكل مع الكروم والكوبالت والتيتانيوم	MB	صمامات العوادم، القوة الميكانيكية الجيدة، مقاومة الكلال والتآكل والصدأ، تعمل عند درجة حرارة 820 درجة مئوية
MG	المعدن الثنائي	MD	MB	صمامات العادم التي تعمل عند درجة حرارة 750 درجة مئوية

# كيفية استخدام هذا الكتالوج



AR

## FIAT GROUP

172 1

80.50 2

Petrol



159 A2.000 3	4 Cyl.	9.2:1	1372cc	57kW (78)PS	4 TD9728	911 5
160 A1.000	4 Cyl.	9.2:1	1372cc	52-56kW (71-76)PS	TD1015	911
836 A4.000	4 Cyl.	9.2:1	1372cc	51kW (69)PS	TD893	912

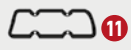

BR620 Fibre Composite

DR620

GR620

HBS051

JD146

JF150

JP049

(Cork)

JN805

HR363

NA5187

30.00x52.00x7.00mm ACM



BR620

جوان المجمع 10

= A = أيسر

= B = أيمن

= S = مجموعة

= K = السحب

العام

= A = العلوي

= B = السفلي

حشية غطاء الصمام 11

= A = أيسر

= B = أيمن

= I = السحب

العام

= E = مجموعة

سدادة ساق الصمام 12

= S = مجموعة

= I = السحب

العام

سدادات زيت عمود الكامات 13

= F = الأمامية

= R = الخلفية

مجموعة مسمار ذو ر 9

شكل مسمار الرأس



سداسي ذكر



سداسي أنثى



نجمة ذكر



نجمة أنثى



مسامير مشقوفة أنثى



حلقة سداسية



رأس مخددة أنثى  
(Ribe-CV®)\*

\*Ribe-CV®

هي علامة تجارية مسجلة لصالح شركة

Richard Bergner GmbH & Co.

رقم اللوحة 1

حجم التجويف 2

تفاصيل المحرك 3

F-M مستند المواصفات / رقم محرك 4

رقم لوحة المحرك السفلية المطابقة 5

حشية رأس الأسطوانة 6

= A = أيسر

= B = أيمن

= K = بروز الكباس

سمك = A

علامة التعريف 1 = فتحة

مجموعة الرأس 7

= A = بدون حشية رأس الأسطوانة

= B = بدون السدادات

= C = بدون حشية غطاء الصمام

= D = بدون سدادات ساق الصمام

مجموعة كاملة 8

= A = بدون حشية رأس الأسطوانة

= B = بدون السدادات

= C = بدون حشية غطاء الصمام

= D = بدون سدادات ساق الصمام

# كيفية استخدام هذا الكتالوج

AR



FIAT GROUP

898 1	80.00 2	Petrol					
AR 00548 3	4 Cyl.	1779cc	83-97kW (113-132)PS	4	TD18	152 5	
AR 01608	4 Cyl.	1779cc	87-89kW (118-121)PS		TD5340	154	
AR 01608 X	4 Cyl.	1779cc	85kW (115)PS		TD33	155	
AR 01678	4 Cyl.	1779cc	88-90kW (120-122)PS		TD38	154	
AR 06168	4 Cyl.	1779cc	88kW (120)PS		TD54	157	
AR 06202	4 Cyl.	1779cc	85-89kW (116-121)PS		TD55	157	
AR 61102	4 Cyl.	9:1	1779cc		TD10149	157	

87-528500-00 6 A 33.25 B- 13.35 D 80.10 22x69	STD 10	08-528500-00 7 1.50 CR P 1.75 P 3.50 P	15-632600-00 WH [1] B 85.00 C 152.00 D 98.00 E 107.50 8 9	89-528500-00 87-528500-00 + 15-632600-00 11
---	-----------	---	---	---

[1] Includes seals [1] Inclut des joints [1] Comprende le guarnizioni [1] Incluye los sellos

BE/PL 13	4	49.988/49.998	53.695/53.708	23.440	1.838	0.021/0.069	BS	60010CP	71-4168/4 STD 0.25 0.50
MB/HL 1,3,5	3	59.960/59.973	63.657/63.676	25.530	1.837	0.020/0.067	BS	60011CP	H1030/5 STD 0.25 0.50
MB/HL 2,4	2	59.960/59.973	63.657/63.676	18.360	1.837	0.020/0.067	BS	60012CP	
TW/A	4	65.786/66.040	82.423/82.677		2.362		AL-LF	2777AF	A178/4 STD

- 7 مرجع مجموعة الحلقة  
عرض الحلقة  
تصميم الحلقة  
معالجة سطح الحلقة  
مرجع البطانة  
B = القطر الخارجي  
C = الطول الكلي  
D = قطر الشفة  
E = عرض الشفة  
F = طول شفة الحماية من النيران
- 8  
D = جاف  
WH = حجر شحذ رطب  
DH = حجر شحذ جاف
- 9  
D = نوع البطانة  
D = جاف
- 10 (صورة الكباس ورقم السبيكة) إن وجد  
11 رقم مجموعى المكابس  
12 [ ] = المذكرة التقنية
- 1 رقم اللوحة  
2 حجم التجوي  
3 تفاصيل المح  
4 مستند المواصفات / رقم محرك FM  
5 رقم لوحة المحركة السفلية المطاب  
6 مراجع حزام التوقي  
A = ارتفاع الضغط  
B = عمق الغرفة/ارتفاع التاج  
BØ = قطر الغرفة  
C = عمق جيب الصمام  
D = الطول  
RT = إدراج ألفين  
KK = منصة تبريد الزيت  
AK = قطع نفت الزيت  
HA = بطانة مؤكسدة قوية على التاج  
NB = جلبة بنز برونزي  
TP = أبعاد شبه المنحرف





# كيفية استخدام هذا الكتالوج



AR

- 13 نوع المحمل وموضعه  
BE/PL = محمل (ذو طرف كبير) قضيب التوصيل  
IMB/HL = MB/HL المحمل الرئيسي  
TW/A = حلقة دفع  
SE/PB = جلبة (ذات طرف صغير) مسامير الكباس  
CB/NWB = جلبة عمود الكامات  
BU = الجلب الأخرى
- 14 مجموعة التركيب
- 15 الحد الأدنى والأقصى لقطر المرتركز القياسي
- 16 الحد الأدنى والأقصى للقطر الداخلي لتجويف الحو
- 17 الحد الأقصى لعرض المح
- 18 الحد الأقصى لسماك الحائط القيا
- 19 خلوص الزيت
- 20 رموز مواد المحم  
AL = ثنائي/ثلاثي المعدن ألومنيوم مظهر بالصلب  
B = نحاس حاس  
BB = ثنائي المعدن بابت مظهر بالصلب  
BC = ثنائي المعدن برونز مصبوب مظهر بالصلب - غير مطلي  
BS = ثنائي المعدن برونز مصبوب مظهر بالصلب - غير مطلي  
EC = ثنائي/ثلاثي المعدن برونز مظهر بالصلب - مطلي بالكهرباء  
SP = ثنائي المعدن بابت مظهر بالصلب  
IX = ألومنيوم مظهر بالصلب - بوليمر  
LF = خالية من الرصاص
- 21 مرجع المركب
- 22 والأحجام الأقل المتوفرة Glyco مرجع مجموعة
- H = محمل رئيسي  
N = جلبة عمود الكومات  
A = حلقة دفع  
.../ = عدد الأزواج (المحامل) أو القطع (الحلقات/الجلب) لكل مجموعة  
...H = محمل (شفة) الدفع

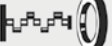

FIAT GROUP			
995	82.60	Diesel	
149 B2.000	4 Cyl.	20:1	1697cc
			42kW (57)PS
			TD16864 295
 EV684	 JJ298 (Cork)	 NB742 30.00x43.00x3.00mm, ACM NB732 74.00x90.00x10.00mm, FPM	
	 JJ298		

- 25 مانع تسريب عمود الكرنك  
F = الأمامية  
R = الخلفية

- 24 حشية الحوض  
S = مجموعة

- 23 مجموعة التحويل  
▲ = بدون حشية رأس الأسطوانة  
■ = بدون السدادات  
☒ = بدون حشية غطاء الصمام  
● = بدون سدادات ساق الصمام

# TERMS OF BUSINESS

## IMPORTANT

EN

Reproduction of this catalogue or parts thereof is only allowed with our explicit permission in writing. Pictorial representations and design are copyrighted. Claims for damages, of any form whatsoever, resulting from details made in this catalogue or from incorrect use, application, storage or handling, are explicitly excluded. Contractual rights and any resulting or related claims based thereon, irrespective of form, initially come into being on the basis of a separate written agreement, in particular on the basis of our general terms of sale and delivery.

All former statements lose their validity with the publication of this catalogue.

The catalogue is not an operating manual for the use and installation of the engine and sealing parts. It does not contain any advice in a legal sense. The catalogue neither replaces the constantly applicable technical regulations - particularly for tolerances - nor the installation and maintenance stipulations of the individual engine manufacturer.

Also, it is not possible to forego the expertise of those carrying out the installation and application. The individual references made in this catalogue for the installation and the application of the engine and sealing parts are instructions solely for the technically qualified specialist and are to be checked and verified by them for their suitability in each case. Federal-Mogul accepts no responsibility for application decisions.

The contents of the catalogue are not intended to create or substitute any contractual agreement which has to be reserved exclusively to a separate agreement between 2 identified parties, whereby seller can be only one of our Federal-Mogul entities as mentioned on the back cover page.

The right is retained to correct errors and alterations, particularly with regard to amendments in the engine manufacturers details and stipulations.

## GESCHÄFTSBEDINGUNGEN – WICHTIGE HINWEISE

DE

Nachdruck, auch auszugsweise, ist nur mit unserer ausdrücklichen schriftlichen Zustimmung gestattet. Die bildlichen Darstellungen und Ausstattungen sind geschützt. Ersatzansprüche, gleich welcher Art, aufgrund der Angaben in diesem Katalog oder auf Grund unsachgemäßem Umgang, unsachgemäßer Verwendung, Lagerung oder Handhabung der angebotenen Produkte, sind ausdrücklich ausgeschlossen. Vertragliche Ansprüche und daraus abgeleitete oder darauf beruhende Ansprüche, gleich welcher Art, kommen erst auf Grund einer besonderen schriftlichen Vereinbarung, insbesondere auf der Grundlage unserer allgemeinen Verkaufs- und Lieferbedingungen, zustande.

Der Katalog ist keine Einbauanleitung für Motorenteile und Dichtungen.

Er enthält keine Beratung im Rechtssinne. Der Katalog ersetzt weder die immer vorrangigen technischen Vorschriften, insbesondere für Toleranzen, sowie die Einbau- und Wartungsvorschriften des jeweiligen Motorenherstellers, noch kann auf das notwendige Fachwissen des die Montage und die Verwendung Durchführenden verzichtet werden. Die in diesem Katalog jeweils gegebenen Hinweise für Einbau und Verwendung der Motorenteile und Dichtungen sind Hinweise ausschließlich für den technisch ausgebildeten und versierten Fachmann, die von ihm im jeweiligen Anwendungsfall auf ihre Eignung geprüft und entschieden werden müssen. Eine Haftung wird von Federal-Mogul für Anwendungsentscheidungen nicht übernommen.

Die Inhalte dieses Katalogs sind nicht dazu bestimmt eine vertragliche Verpflichtung zu begründen oder zu ersetzen, was ausschliesslich einer gesonderten Vereinbarung zwischen 2 konkret bezeichneten Parteien vorbehalten bleibt, wobei der Verkäufer eine unserer Federal-Mogul Gesellschaften sein wird, wie auf der Rückseite des Kataloges.

Die Korrektur von Irrtümern und Änderungen, in besondere auf Grund von geänderten Angaben und Vorschriften der Motorenhersteller, bleibt vorbehalten.

## CONDIZIONI GENERALI – IMPORTANTE

IT

La riproduzione di questo catalogo, anche parziale, è permessa soltanto in seguito ad una autorizzazione scritta. I grafici ed i disegni sono marchio depositato. Reclami per difetti, di qualsiasi natura essi siano, relativi al contenuto di questo catalogo, o all'uso improprio di esso, verranno respinti. Le pretese avanzate od i reclami dovranno essere in conformità con le nostre condizioni generali di vendita.

Il presente catalogo annulla e sostituisce tutte le edizioni precedenti.

Il catalogo non è un manuale per l'utilizzo ed il montaggio delle ricambi motore e tenute. Non contiene indicazioni in questo senso. Esso non sostituisce le descrizioni tecniche, sempre prioritarie, in particolare per le tolleranze, né le istruzioni relative al montaggio ed alla manutenzione date dai costruttori dei rispettivi motori. Non può in nessun caso essere paragonato alla conoscenza professionale necessaria per il montaggio e l'utilizzo. Le considerazioni sul montaggio delle ricambi motore e tenute, fatte su questo catalogo, sono destinate esclusivamente a professionisti con formazione tecnica i quali verificheranno l'esattezza della informazioni, in ogni caso.

Le responsabilità derivanti dall'utilizzo improprio dello stesso non potranno essere addebitate alla Federal-Mogul.

I contenuti del catalogo non sostituiscono in alcun modo gli accordi contrattuali che sono riservati esclusivamente a due contraenti definiti; come venditore si intende una delle società Federal Mogul menzionate sul retro del catalogo.

Ci riserviamo di apportare correzioni e modifiche, relative, in particolare, a dati o istruzioni ricevute dal costruttore del motore.

## CONDITIONS GÉNÉRALES DE VENTE – IMPORTANT

FR

La reproduction de ce catalogue, même partielle, n'est autorisée qu'avec notre accord préalable et par écrit. Les illustrations graphiques et la présentation font l'objet d'un copyright. Nous excluons toutes réclamations ayant pour objet ce catalogue ou pouvant résulter de son incompréhension, portant sur de mauvaises utilisations, manipulations, manutentions ou mauvais stockage. Des droits contractuels et des droits dérivés, de quelque nature qu'ils soient, ne peuvent résulter que d'un accord écrit, particulièrement sur la base de nos conditions générales de ventes et de livraisons.

Ce catalogue annule et remplace toute édition antérieure.

Le catalogue n'est pas une notice d'utilisation et de montage des pièces moteur et joints. Il ne contient pas de directives en tant que telles. Le catalogue ne remplace ni les prescriptions techniques, toujours prioritaires, particulièrement pour les tolérances, ni les prescriptions de montage et d'entretien des constructeurs des moteurs figurant dans ce catalogue. Il ne peut en aucun cas remplacer les connaissances professionnelles nécessaires pour le montage et l'utilisation. Les remarques données pour le montage et l'utilisation des pièces moteur et joints sont exclusivement destinées au professionnel averti et de formation technique, à qui il appartiendra de vérifier la conformité des indications pour chaque cas. La responsabilité des décisions d'utilisation ne peut être prise en charge par Federal-Mogul.

Le contenu de ce catalogue ne peut constituer ou remplacer un contrat qui doit faire l'objet d'un document séparé établi entre 2 parties, dont l'une doit être une entité légale de Federal-Mogul dont la liste figure sur la couverture arrière.

Nous nous réservons le droit d'apporter toutes corrections d'erreurs et modifications, suite notamment à de nouvelles données fournies par les constructeurs.

# TERMS OF BUSINESS

## CONDICIONES DE VENTA – IMPORTANTE

ES

Queda totalmente prohibida la reproducción, total o parcial, del contenido de este catálogo, salvo previa autorización nuestra, realizada por escrito. Están, asimismo, reservados todos los derechos sobre el diseño y presentación del catálogo. No se aceptará ningún tipo de reclamación que esté basada en la interpretación de los datos contenidos en este catálogo, así como en el incorrecto uso, manipulación o almacenaje de nuestras piezas. Únicamente se aceptarán reclamaciones que estén basadas en derechos contractuales o en los motivos arriba indicados, siempre que exista un acuerdo especial y por escrito basado en nuestras condiciones generales de venta y suministro.

Con la edición de este catálogo queda anulada toda la información contenida en catálogos anteriores.

El catálogo no es un manual para el uso e instalación de los piezas de motor y sellado, y no representa una asesoría técnica, en el sentido legal. Los datos del catálogo no sustituyen, en ningún caso, a las especificaciones técnicas, tanto en lo que se refiere a tolerancias como a las instrucciones de instalación y mantenimiento, indicadas por los fabricantes de los motores, especificaciones que serán siempre prioritarias. Se entiende que el uso y montaje de estas piezas está encomendado a personal debidamente cualificado. Las indicaciones sobre uso y montaje de los piezas de motor y sellado contenidas en este catálogo, están exclusivamente dirigidas a profesionales con la debida capacitación y formación técnica, que deben decidir en cada caso sobre la exactitud de las mismas. La responsabilidad de estas decisiones no puede ser, en ningún caso, achacada a Federal-Mogul.

La información facilitada en el catálogo no representa o sustituye ningún tipo de acuerdo, quedando a tal efecto, el acuerdo por separado entre dos partes donde sólo entidades de Federal-Mogul, pueden ser identificadas como la parte vendedora como se menciona en la contraportada.

Los datos e instrucciones contenidos en este catálogo podrán ser corregidos o modificados sin previo aviso.

## WARUNKI PROWADZENIA BIZNESU – WAŻNE

PL

Reprodukcja tego katalogu lub jego części jest możliwa tylko za wyraźną zgodą na piśmie. Ilustracje i grafika są chronione prawem autorskim. Roszczenia dotyczące szkód, niezależnie od formy, wynikających z przedstawionych w tym katalogu treści lub z nieprawidłowego użycia, zastosowania, przechowywania lub obsługi są w sposób wyraźny wyłączone. Prawa umowne i inne wynikające lub związane z roszczeniami na nimi opartymi, niezależnie od formy, są tworzone na podstawie oddzielnej umowy pisemnej, w szczególności na podstawie naszych ogólnych warunków sprzedaży i dostawy. Wszystkie wcześniejsze oświadczenia tracą ważność wraz z opublikowaniem tego katalogu.

Katalog nie jest instrukcją użytkownika i montażu części silnikowych i uszczelnień. Nie zawiera porad w sensie prawnym. Katalog nie zastępuje obowiązujących uregulowań technicznych – zwłaszcza w zakresie tolerancji – ani opisów montażu i konserwacji poszczególnych producentów silników. Nie jest również możliwe pominięcie doświadczenia osob dokonujących doboru i przeprowadzających montaż części. Poszczególne odniesienia zawarte w tym katalogu, a dotyczące doboru, montażu i stosowania części silnikowych i uszczelnień, są instrukcjami wyłączone dla wykwalifikowanego technicznie specjalisty, który w każdym przypadku musi je sprawdzić i zweryfikować ich przydatność. Federal-Mogul nie przyjmuje odpowiedzialności za decyzje dotyczące zastosowania.

Zawartość tego katalogu nie stanowi ani nie zastępuje umowy, która może być zawarta jedynie jako oddzielny dokument podpisany przez dwie strony, przy czym sprzedawcą może być tylko jedna z jednostek koncernu Federal-Mogul, zgodnie z opisem na wewnętrznej stronie tylnej okładki.

Zachowane zostaje prawo korygowania błędów i wprowadzania zmian, zwłaszcza odnośnie zmian dotyczących parametrów i warunków pracy określonych przez producentów silników.

## УСЛОВИЯ ДЕЛОВОГО СОТРУДНИЧЕСТВА – ВАЖНО

RU

Копирование данного каталога или его частей допускается исключительно при получении нашего разрешения в письменной форме. Иллюстрации и дизайн защищены авторским правом. Требования о возмещении ущерба любой формы, исходя из содержания каталога или из-за неправильного использования, хранения или обращения, абсолютно исключены. Договорные права и любые результирующие или связанные с этим требования, независимо от их формы, должны являться частью отдельного письменного соглашения и основываться на наших общих условиях продаж и поставок.

Все прежние утверждения теряют свою юридическую силу с момента публикации данного каталога.

Каталог не является руководством пользователя и инструкцией по установке деталей двигателя и уплотнения. Он не содержит советов в юридическом понимании этого слова. Каталог не является заменой для издаваемых производителями двигателей технических инструкций по ремонту, в особенности для допусков технических величин, а также инструкций по монтажу и регламентному обслуживанию. Отдельные ссылки для установки и замены деталей двигателя и уплотнения, приведенные в этом каталоге, являются инструкциями исключительно для технически компетентного специалиста и в каждом случае должны быть проверены им на предмет их пригодности. Federal-Mogul не несет ответственность за ремонтные работы.

Содержимое каталога не предназначено для создания или замены любого контрактного соглашения, которое может быть оформлено только в виде отдельного соглашения между двумя установленными сторонами, где продавцом может являться только одно из юридических лиц Federal-Mogul, как упомянуто на внутренней стороне обложки каталога. Federal-Mogul оставляет за собой право вносить исправления и изменения в частности в отношении поправок по деталям изготовителей двигателей и их условиям.

AR

هام

يخطر نسخ أي جزء من هذا الكatalog دون موافقة صريحة كتابية منا. جميع حقوق التصوير والتصميم محفوظة. إن المطالبات بالتعويض عن أي تلفيات من أي نوع مهما كانت، والتي تنتج عن التفاصيل المقدمة بهذا الكatalog أو عن الاستخدام غير الصحيح، أو التطبيق غير السليم أو التخزين أو التعامل مستعدة هنا بوضوح. تأتي حقوق التعاقد أو أي متطلبات ناتجة أو ذات صلة بالاعتماد على ذلك - بغض النظر عن النموذج - أولاً كي تكون على أساس اتفاق مكتوب منفصل، وعلى وجه الخصوص، على أساس الشروط العامة للبيع والتوصيل

تصبح جميع البيانات السابقة لاغية في حالة نشر هذا الكatalog

ولا يعد هذا الكatalog دليل تشغيل لاستخدام وتركيب المحرك وقطع غيار الحشية، ولا ينطوي على أي نصيحة ذات معنى قانوني. كما أن هذا الكatalog لا يحل محل التنظيمات الفنية سارية المفعول بصفة دائمة - وبصفة خاصة قدرات التحمل - ولا اشتراطات التركيب والصيانة المحددة من قبل جهة تصنيع المحرك

كما أنه ليس ممكناً الامتناع عن تقديم الخبرة للقاءمين بعملية التركيب والتطبيق. إن الإشارات الفردية المقدمة في هذا الكatalog بشأن التركيب والتطبيق المحرك وقطع غيار الحشية وهي إرشادات فقط للمتخصصين المؤهلين فنياً وينبغي أي مسؤولية تتعلق بمسائل الاستعمال Federal-Mogul عليه مراجعتها والتحقق منها لمناسبتها لكل حالة. لا تتحمل شركة

كما هو مدون على صفحة الغلاف Federal-Mogul لا تستهدف محتويات الكatalog إبرام أي اتفاق تعاقدي يجب الاحتفاظ به أو تبديله باستثناء الاتفاق المنفصل بين الطرفين المحددين، وبناءً عليه لا يكون البائع إلا أحد كيانات شركة الخلفية

الحقوق محفوظة لتصحيح الأخطاء وعمليات التغيير، خاصة فيما يتعلق بالتعديلات الطارئة على تفاصيل واشتراطات جهات تصنيع المحركات

© Federal-Mogul Corporation 2014

The contents of this publication are the copyright of Federal-Mogul Corporation. Unauthorised reproduction in whole or in part is expressly forbidden.

ENGINE EXPERTISE BY  FEDERAL-MOGUL MOTORPARTS





ccm



9



07/81→12/86	6 2.0	AR 01932	Petrol	1997	V6		903
04/79→12/86	6 2.5	AR 01928	Petrol	2492	V6	596	1238
07/81→05/86	6 2.5	VM-HR 588 HT	Diesel	2493	5	604	1228
06/83→12/89	33 1.2	AR 30585	Petrol	1186	4	132	882
05/83→12/89	33 1.3	AR 30502	Petrol	1351	4	138	880
06/83→12/89	33 1.3	AR 30586	Petrol	1351	4	138	880
10/84→12/89	33 1.3	AR 30168	Petrol	1351	4	137	880
10/84→12/89	33 1.3	AR 30587	Petrol	1351	4	138	878
06/91→09/94	33 1.4	AR 30753	Petrol	1351	4	139	885
06/91→09/94	33 1.4	AR 30755	Petrol	1351	4	140	885
05/83→12/93	33 1.5	AR 30182	Petrol	1490	4	364	1049
06/83→12/85	33 1.5	AR 30143	Petrol	1490	4	362	1050
06/83→12/85	33 1.5	AR 30504	Petrol	1490	4	365	1049
06/83→12/86	33 1.5	AR 30520	Petrol	1490	4	361	1049
01/84→12/89	33 1.5	AR 30514	Petrol	1490	4	366	1052
06/84→12/89	33 1.5	AR 30146	Petrol	1490	4	363	1049
06/84→12/89	33 1.5	AR 30508	Petrol	1490	4	363	1049
06/84→12/89	33 1.5	AR 30588	Petrol	1490	4	367	1053
01/90→04/93	33 1.5	AR 30734	Petrol	1490	4	368	1051
01/90→09/94	33 1.5	AR 30751	Petrol	1490	4	370	1054
07/90→08/91	33 1.5	AR 30750	Petrol	1490	4	369	1054
01/86→12/89	33 1.7	AR 30550	Petrol	1712	4	563	1216
09/88→12/89	33 1.7	AR 30558	Petrol	1712	4	564	1217
01/90→09/94	33 1.7	AR 30736	Petrol	1712	4	565	1217
01/90→09/94	33 1.7	AR 30737	Petrol	1712	4	565	1217
01/90→09/94	33 1.7	AR 30746	Petrol	1712	4	568	1221
01/90→09/94	33 1.7	AR 30747	Petrol	1712	4	568	1221
04/92→09/94	33 1.7	AR 30737 A	Petrol	1712	4	566	1219
01/86→06/90	33 1.8	VM 82 A	Diesel	1779	3	605	1245
07/90→09/94	33 1.8	VM 96 A	Diesel	1779	3	605	1245
01/84→12/88	33 SPORTWAGON 1.3	AR 30587	Petrol	1351	4	138	878
06/91→09/94	33 SPORTWAGON 1.4	AR 30753	Petrol	1351	4	139	885
06/91→09/94	33 SPORTWAGON 1.4	AR 30755	Petrol	1351	4	140	885
09/84→12/86	33 SPORTWAGON 1.5	AR 30520	Petrol	1490	4	361	1049
09/84→12/87	33 SPORTWAGON 1.5	AR 30182	Petrol	1490	4	364	1049
09/84→12/87	33 SPORTWAGON 1.5	AR 30514	Petrol	1490	4	366	1052
12/86→12/89	33 SPORTWAGON 1.5	AR 30146	Petrol	1490	4	363	1049
12/86→12/89	33 SPORTWAGON 1.5	AR 30508	Petrol	1490	4	363	1049
12/86→12/89	33 SPORTWAGON 1.5	AR 30588	Petrol	1490	4	367	1053
01/90→09/94	33 SPORTWAGON 1.5	AR 30751	Petrol	1490	4	370	1054
03/88→12/89	33 SPORTWAGON 1.7	AR 30550	Petrol	1712	4	563	1216
09/88→12/89	33 SPORTWAGON 1.7	AR 30558	Petrol	1712	4	564	1217
09/88→09/94	33 SPORTWAGON 1.7	AR 30737	Petrol	1712	4	565	1217
01/90→03/92	33 SPORTWAGON 1.7	AR 30736	Petrol	1712	4	565	1217
01/90→03/92	33 SPORTWAGON 1.7	AR 30746	Petrol	1712	4	568	1221
01/90→09/94	33 SPORTWAGON 1.7	AR 30747	Petrol	1712	4	568	1221
01/86→12/89	33 SPORTWAGON 1.8	VM 96 A	Diesel	1779	3	605	1245
05/85→09/89	75 1.6	AR 06100	Petrol	1567	4	107	854
05/85→02/92	75 1.6	AR 61101	Petrol	1567	4	112	859
09/85→06/89	75 1.8	AR 06202	Petrol	1779	4	157	898
02/86→01/90	75 1.8	AR 06158	Petrol	1779	4	156	899
09/86→02/92	75 1.8	AR 06134	Petrol	1779	4	156	899
09/88→02/92	75 1.8	AR 06168	Petrol	1779	4	157	898
09/88→02/92	75 1.8	AR 61102	Petrol	1779	4	157	898
05/89→12/92	75 1.8	AR 61202	Petrol	1779	4	158	899
08/89→02/92	75 1.8	AR 61201	Petrol	1779	4	158	900
08/89→02/92	75 1.8	AR 67101	Petrol	1773	4	412	1093
05/85→10/88	75 2.0	AR 06212	Petrol	1962	4	421	1103
05/85→02/92	75 2.0	AR 06224	Petrol	1962	4	422	1106
05/85→09/92	75 2.0	VM 80 A	Diesel	1995	4	579	1228
01/87→02/92	75 2.0	AR 06166	Petrol	1962	4	422	1105
01/89→02/92	75 2.4	VM 81 A	Diesel	2393	4	607	1245
05/85→08/86	75 2.5	AR 01646	Petrol	2492	V6	593	1238
05/85→08/86	75 2.5	AR 01911	Petrol	2492	V6	595	1238
09/86→04/89	75 2.5	AR 01648	Petrol	2492	V6	594	1239
01/87→12/90	75 3.0	AR 06120	Petrol	2959	V6	688	1325
01/87→02/92	75 3.0	AR 06124	Petrol	2959	V6	688	1325
02/90→02/92	75 3.0	AR 61503	Petrol	2959	V6	688	1325
10/84→07/87	90 1.8	AR 06202	Petrol	1779	4	157	898
10/84→07/87	90 2.0	AR 01713	Petrol	1962	4	421	1098
10/84→07/87	90 2.0	AR 06210	Petrol	1997	V6	163	903
10/84→07/87	90 2.0	AR 06212	Petrol	1962	4	421	1103





ccm

X



9



10/84→07/87	<b>90 2.4</b>	VM 81 A	Diesel	2393	4	<b>607</b>	<b>1245</b>
10/84→07/87	<b>90 2.5</b>	AR 01646	Petrol	2492	V6	<b>593</b>	<b>1238</b>
10/84→07/87	<b>90 2.5</b>	AR 01911	Petrol	2492	V6	<b>595</b>	<b>1238</b>
07/94→12/96	<b>145 1.4</b>	AR 33501	Petrol	1351	4	<b>140</b>	<b>885</b>
12/96→01/01	<b>145 1.4</b>	AR 33503	Petrol	1370	4	<b>187</b>	<b>924</b>
12/96→01/01	<b>145 1.4</b>	AR 38501	Petrol	1370	4	<b>187</b>	<b>924</b>
10/94→12/96	<b>145 1.6</b>	AR 33201	Petrol	1596	4	<b>393</b>	<b>1074</b>
12/96→01/01	<b>145 1.6</b>	AR 38201	Petrol	1598	4	<b>192</b>	<b>926</b>
12/96→01/01	<b>145 1.6</b>	AR 67601	Petrol	1598	4	<b>193</b>	<b>926</b>
09/97→12/00	<b>145 1.6</b>	AR 32102	Petrol	1598	4	<b>189</b>	<b>926</b>
10/94→12/96	<b>145 1.7</b>	AR 33401	Petrol	1712	4	<b>569</b>	<b>1221</b>
12/96→12/98	<b>145 1.7</b>	AR 38401	Petrol	1747	4	<b>205</b>	<b>933</b>
12/96→12/98	<b>145 1.7</b>	AR 67106	Petrol	1747	4	<b>206</b>	<b>933</b>
12/96→12/98	<b>145 1.7</b>	AR 67199	Petrol	1747	4	<b>207</b>	<b>934</b>
03/98→01/01	<b>145 1.7</b>	AR 32201	Petrol	1747	4	<b>203</b>	<b>933</b>
10/94→02/99	<b>145 1.9</b>	AR 33601	Diesel	1929	4	<b>325</b>	<b>1014</b>
10/94→02/99	<b>145 1.9</b>	AR 67501	Diesel	1929	4	<b>326</b>	<b>1014</b>
02/99→01/01	<b>145 1.9</b>	AR 32302	Diesel	1910	4	<b>253</b>	<b>937</b>
10/95→01/01	<b>145 2.0</b>	AR 67204	Petrol	1970	4	<b>351</b>	<b>1038</b>
03/98→01/01	<b>145 2.0</b>	AR 32301	Petrol	1970	4	<b>346</b>	<b>1038</b>
12/94→12/96	<b>146 1.4</b>	AR 33501	Petrol	1351	4	<b>140</b>	<b>885</b>
11/96→01/01	<b>146 1.4</b>	AR 33503	Petrol	1370	4	<b>187</b>	<b>924</b>
11/96→01/01	<b>146 1.4</b>	AR 38501	Petrol	1370	4	<b>187</b>	<b>924</b>
12/94→12/96	<b>146 1.6</b>	AR 33201	Petrol	1596	4	<b>393</b>	<b>1074</b>
11/96→01/01	<b>146 1.6</b>	AR 38201	Petrol	1598	4	<b>192</b>	<b>926</b>
11/96→01/01	<b>146 1.6</b>	AR 67601	Petrol	1598	4	<b>193</b>	<b>926</b>
09/97→12/00	<b>146 1.6</b>	AR 32102	Petrol	1598	4	<b>189</b>	<b>926</b>
12/94→12/96	<b>146 1.7</b>	AR 33401	Petrol	1712	4	<b>569</b>	<b>1221</b>
11/96→01/01	<b>146 1.7</b>	AR 38401	Petrol	1747	4	<b>205</b>	<b>933</b>
11/96→01/01	<b>146 1.7</b>	AR 67106	Petrol	1747	4	<b>206</b>	<b>933</b>
03/98→01/01	<b>146 1.7</b>	AR 32201	Petrol	1747	4	<b>203</b>	<b>933</b>
12/94→02/99	<b>146 1.9</b>	AR 33601	Diesel	1929	4	<b>325</b>	<b>1014</b>
12/94→02/99	<b>146 1.9</b>	AR 67501	Diesel	1929	4	<b>326</b>	<b>1014</b>
02/99→01/01	<b>146 1.9</b>	AR 32302	Diesel	1910	4	<b>253</b>	<b>937</b>
10/95→01/01	<b>146 2.0</b>	AR 67204	Petrol	1970	4	<b>351</b>	<b>1038</b>
03/98→01/01	<b>146 2.0</b>	AR 32301	Petrol	1970	4	<b>346</b>	<b>1038</b>
01/01→03/10	<b>147 1.6</b>	AR 32104	Petrol	1598	4	<b>190</b>	<b>927</b>
01/01→03/10	<b>147 1.6</b>	AR 37203	Petrol	1598	4	<b>191</b>	<b>928</b>
11/00→09/04	<b>147 1.9</b>	AR 37101	Diesel	1910	4	<b>256</b>	<b>954</b>
04/01→03/10	<b>147 1.9</b>	937 A2.000	Diesel	1910	4	<b>236</b>	<b>954</b>
11/02→03/10	<b>147 1.9</b>	192 A5.000	Diesel	1910	4	<b>224</b>	<b>946</b>
06/03→03/10	<b>147 1.9</b>	182 B9.000	Diesel	1910	4	<b>212</b>	<b>938</b>
09/03→09/04	<b>147 1.9</b>	937 A4.000	Diesel	1910	4	<b>238</b>	<b>946</b>
09/04→03/10	<b>147 1.9</b>	937 A5.000	Diesel	1910	4	<b>241</b>	<b>946</b>
10/04→03/10	<b>147 1.9</b>	192 B1.000	Diesel	1910	4	<b>224</b>	<b>946</b>
10/04→03/10	<b>147 1.9</b>	939 A7.000	Diesel	1910	4	<b>250</b>	<b>960</b>
07/05→03/10	<b>147 1.9</b>	937 A3.000	Diesel	1910	4	<b>237</b>	<b>948</b>
06/08→03/10	<b>147 1.9</b>	937 A6.000	Diesel	1910	4	<b>242</b>	<b>956</b>
01/01→03/10	<b>147 2.0</b>	AR 32310	Petrol	1970	4	<b>348</b>	<b>1040</b>
07/02→05/05	<b>147 2.0</b>	937 A1.000	Petrol	1970	4	<b>344</b>	<b>1037</b>
02/03→03/10	<b>147 3.2</b>	932 A.000	Petrol	3179	V6	<b>707</b>	
05/96→12/97	<b>155 1.6</b>	AR 67601	Petrol	1598	4	<b>193</b>	<b>926</b>
04/93→04/96	<b>155 1.7</b>	AR 67103	Petrol	1748	4	<b>358</b>	<b>1046</b>
04/93→04/96	<b>155 1.7</b>	AR 67105	Petrol	1748	4	<b>359</b>	<b>1047</b>
05/96→12/97	<b>155 1.7</b>	AR 67106	Petrol	1747	4	<b>206</b>	<b>933</b>
01/92→12/96	<b>155 1.8</b>	AR 67101	Petrol	1773	4	<b>412</b>	<b>1093</b>
01/92→12/96	<b>155 1.8</b>	AR 67102	Petrol	1773	4	<b>412</b>	<b>1093</b>
02/92→12/97	<b>155 1.8</b>	AR 67402	Petrol	1756	4	<b>412</b>	<b>1092</b>
04/93→12/97	<b>155 1.9</b>	AR 67501	Diesel	1929	4	<b>326</b>	<b>1014</b>
01/92→12/97	<b>155 2.0</b>	AR 67203	Petrol	1995	4	<b>482</b>	<b>1152</b>
02/92→04/93	<b>155 2.0</b>	AR 67201	Petrol	1995	4	<b>481</b>	<b>1151</b>
02/92→02/95	<b>155 2.0</b>	AR 67202	Petrol	1995	4	<b>353</b>	<b>1042</b>
10/92→12/97	<b>155 2.0</b>	AR 67302	Petrol	2492	V6	<b>602</b>	<b>1243</b>
03/95→12/97	<b>155 2.0</b>	AR 67204	Petrol	1970	4	<b>351</b>	<b>1038</b>
03/95→12/97	<b>155 2.0</b>	AR 67299	Petrol	1970	4	<b>352</b>	<b>1041</b>
02/92→09/96	<b>155 2.5</b>	AR 67301	Petrol	2492	V6	<b>601</b>	<b>1243</b>
10/92→12/97	<b>155 2.5</b>	AR 67303	Petrol	2492	V6	<b>603</b>	<b>1243</b>
04/93→12/97	<b>155 2.5</b>	VM 07 B	Diesel	2499	4	<b>608</b>	<b>1248</b>
04/93→12/97	<b>155 2.5</b>	VM 31 B	Diesel	2499	4	<b>609</b>	<b>1248</b>
09/97→09/05	<b>156 1.6</b>	AR 32102	Petrol	1598	4	<b>189</b>	<b>926</b>
09/97→09/05	<b>156 1.6</b>	AR 32103	Petrol	1598	4	<b>190</b>	<b>927</b>
09/97→09/05	<b>156 1.6</b>	AR 32104	Petrol	1598	4	<b>190</b>	<b>927</b>



ccm

X



9



09/97→09/05	156 1.6	AR 67601	Petrol	1598	4	193	926
09/97→10/00	156 1.7	AR 32201	Petrol	1747	4	203	933
10/00→09/05	156 1.8	AR 32205	Petrol	1747	4	204	933
09/97→10/00	156 1.9	AR 32302	Diesel	1910	4	253	937
10/00→05/01	156 1.9	AR 37101	Diesel	1910	4	256	954
05/01→09/05	156 1.9	937 A2.000	Diesel	1910	4	236	954
11/02→11/04	156 1.9	192 B1.000	Diesel	1910	4	224	946
11/02→09/05	156 1.9	192 A5.000	Diesel	1910	4	224	946
11/03→09/05	156 1.9	937 A4.000	Diesel	1910	4	238	946
07/04→09/05	156 1.9	937 A5.000	Diesel	1910	4	241	946
09/97→10/00	156 2.0	AR 32301	Petrol	1970	4	346	1038
11/97→04/00	156 2.0	AR 32303	Petrol	1970	4	347	1039
10/00→03/02	156 2.0	AR 32310	Petrol	1970	4	348	1040
03/02→09/05	156 2.0	937 A1.000	Petrol	1970	4	344	1037
09/97→09/03	156 2.4	AR 32501	Diesel	2387	5	289	973
10/00→09/05	156 2.4	839 A6.000	Diesel	2387	5	274	976
03/02→09/05	156 2.4	841 C000	Diesel	2387	5	277	976
06/03→09/05	156 2.4	841 M.000	Diesel	2387	5	282	978
06/03→09/05	156 2.4	841 N.000	Diesel	2387	5		984
10/03→09/05	156 2.4	841 G.000	Diesel	2387	5	278	978
09/97→12/01	156 2.5	AR 32401	Petrol	2492	V6	597	1242
09/97→12/01	156 2.5	AR 32402	Petrol	2492	V6		1241
10/00→09/05	156 2.5	AR 32405	Petrol	2492	V6	598	1242
03/02→09/05	156 3.2	932 A.000	Petrol	3179	V6	707	
01/00→05/06	156 SPORTWAGON 1.6	AR 32102	Petrol	1598	4	189	926
05/00→05/06	156 SPORTWAGON 1.6	AR 32103	Petrol	1598	4	190	927
05/00→05/06	156 SPORTWAGON 1.6	AR 32104	Petrol	1598	4	190	927
05/00→05/06	156 SPORTWAGON 1.6	AR 67601	Petrol	1598	4	193	926
05/00→10/00	156 SPORTWAGON 1.7	AR 32201	Petrol	1747	4	203	933
10/00→05/06	156 SPORTWAGON 1.8	AR 32205	Petrol	1747	4	204	933
05/00→10/00	156 SPORTWAGON 1.9	AR 32302	Diesel	1910	4	253	937
10/00→05/01	156 SPORTWAGON 1.9	AR 37101	Diesel	1910	4	256	954
05/01→05/06	156 SPORTWAGON 1.9	937 A2.000	Diesel	1910	4	236	954
11/02→11/04	156 SPORTWAGON 1.9	192 B1.000	Diesel	1910	4	224	946
11/02→05/06	156 SPORTWAGON 1.9	192 A5.000	Diesel	1910	4	224	946
11/03→05/06	156 SPORTWAGON 1.9	937 A4.000	Diesel	1910	4	238	946
07/04→05/06	156 SPORTWAGON 1.9	937 A5.000	Diesel	1910	4	241	946
05/00→06/02	156 SPORTWAGON 2.0	AR 32301	Petrol	1970	4	346	1038
10/00→03/02	156 SPORTWAGON 2.0	AR 32310	Petrol	1970	4	348	1040
03/02→05/06	156 SPORTWAGON 2.0	932 A2.000	Petrol	1970	4	343	1036
03/02→05/06	156 SPORTWAGON 2.0	937 A1.000	Petrol	1970	4	344	1037
05/00→09/03	156 SPORTWAGON 2.4	AR 32501	Diesel	2387	5	289	973
10/00→05/06	156 SPORTWAGON 2.4	839 A6.000	Diesel	2387	5	274	976
03/02→05/06	156 SPORTWAGON 2.4	841 C000	Diesel	2387	5	277	976
06/03→05/06	156 SPORTWAGON 2.4	841 M.000	Diesel	2387	5	282	978
06/03→05/06	156 SPORTWAGON 2.4	841 N.000	Diesel	2387	5		984
10/03→05/06	156 SPORTWAGON 2.4	841 G.000	Diesel	2387	5	278	978
05/00→08/03	156 SPORTWAGON 2.5	AR 32401	Petrol	2492	V6	597	1242
10/00→05/06	156 SPORTWAGON 2.5	AR 32405	Petrol	2492	V6	598	1242
03/02→05/06	156 SPORTWAGON 3.2	932 A.000	Petrol	3179	V6	707	
03/07→11/11	159 1.8	939 A4.000	Petrol	1796	4	182	918
05/09→11/11	159 1.8	939 B1.000	Petrol	1742	4	329	1019
09/05→11/11	159 1.9	937 A7.000	Diesel	1910	4	243	958
09/05→11/11	159 1.9	937 A8.000	Diesel	1910	4	245	959
09/05→11/11	159 1.9	939 A1.000	Diesel	1910	4	246	960
09/05→11/11	159 1.9	939 A2.000	Diesel	1910	4	248	961
09/05→11/11	159 1.9	939 A6.000	Petrol	1859	4	508	1174
09/05→11/11	159 1.9	939 A7.000	Diesel	1910	4	250	960
09/05→11/11	159 1.9	939 A8.000	Diesel	1910	4	251	963
05/09→11/11	159 2.0	844 A2.000	Diesel	1956	4		1034
05/09→11/11	159 2.0	939 B3.000	Diesel	1956	4	341	1032
06/10→11/11	159 2.0	939 B4.000	Diesel	1956	4	340	1035
09/05→11/11	159 2.2	939 A5.000	Petrol	2198	4	518	1174
09/05→11/11	159 2.4	939 A3.000	Diesel	2387	5	287	988
05/07→11/11	159 2.4	939 A9.000	Diesel	2387	5	288	989
12/05→11/11	159 3.2	939 A.000	Petrol	3196	V6	573	
03/07→11/11	159 SPORTWAGON 1.8	939 A4.000	Petrol	1796	4	182	918
05/09→11/11	159 SPORTWAGON 1.8	939 B1.000	Petrol	1742	4	329	1019
03/06→11/11	159 SPORTWAGON 1.9	937 A7.000	Diesel	1910	4	243	958
03/06→11/11	159 SPORTWAGON 1.9	937 A8.000	Diesel	1910	4	245	959
03/06→11/11	159 SPORTWAGON 1.9	939 A1.000	Diesel	1910	4	246	960
03/06→11/11	159 SPORTWAGON 1.9	939 A2.000	Diesel	1910	4	248	961



ccm

X



9



03/06→11/11	<b>159 SPORTWAGON 1.9</b>	939 A6.000	Petrol	1859	4	<b>508</b>	<b>1174</b>
05/09→11/11	<b>159 SPORTWAGON 2.0</b>	844 A2.000	Diesel	1956	4		<b>1034</b>
05/09→11/11	<b>159 SPORTWAGON 2.0</b>	939 B3.000	Diesel	1956	4	<b>341</b>	<b>1032</b>
06/10→11/11	<b>159 SPORTWAGON 2.0</b>	939 B4.000	Diesel	1956	4	<b>340</b>	<b>1035</b>
03/06→11/11	<b>159 SPORTWAGON 2.2</b>	939 A5.000	Petrol	2198	4	<b>518</b>	<b>1174</b>
03/06→11/11	<b>159 SPORTWAGON 2.4</b>	939 A3.000	Diesel	2387	5	<b>287</b>	<b>988</b>
05/07→11/11	<b>159 SPORTWAGON 2.4</b>	939 A9.000	Diesel	2387	5	<b>288</b>	<b>989</b>
03/06→11/11	<b>159 SPORTWAGON 3.2</b>	939 A.000	Petrol	3196	V6	<b>573</b>	
06/87→12/90	<b>164 2.0</b>	AR 06420	Petrol	1995	4	<b>422</b>	<b>1149</b>
06/87→09/98	<b>164 2.0</b>	AR 06416	Petrol	1995	4	<b>422</b>	<b>1149</b>
10/87→09/98	<b>164 2.0</b>	AR 06476	Petrol	1995	4	<b>480</b>	<b>1150</b>
11/87→09/98	<b>164 2.0</b>	AR 64103	Petrol	1995	4	<b>412</b>	<b>1151</b>
03/91→09/92	<b>164 2.0</b>	AR 64101	Petrol	1996	V6	<b>161</b>	<b>902</b>
09/92→09/98	<b>164 2.0</b>	AR 64102	Petrol	1996	V6	<b>162</b>	<b>902</b>
06/87→09/92	<b>164 2.5</b>	VM 84 A	Diesel	2499	4	<b>611</b>	<b>1248</b>
09/92→09/98	<b>164 2.5</b>	AR 66201	Petrol	2492	V6	<b>600</b>	<b>1241</b>
09/92→09/98	<b>164 2.5</b>	VM 08 B	Diesel	2499	4	<b>609</b>	<b>1248</b>
09/92→09/98	<b>164 2.5</b>	VM 32 B	Diesel	2499	4	<b>610</b>	<b>1248</b>
06/87→09/92	<b>164 3.0</b>	AR 06410	Petrol	2959	V6	<b>689</b>	<b>1326</b>
06/87→09/92	<b>164 3.0</b>	AR 06412	Petrol	2959	V6	<b>689</b>	<b>1326</b>
09/90→09/92	<b>164 3.0</b>	AR 06430	Petrol	2959	V6	<b>690</b>	<b>1324</b>
09/90→09/92	<b>164 3.0</b>	AR 64301	Petrol	2959	V6	<b>698</b>	<b>1326</b>
09/92→09/98	<b>164 3.0</b>	AR 64303	Petrol	2959	V6	<b>699</b>	
09/92→09/98	<b>164 3.0</b>	AR 64304	Petrol	2959	V6	<b>700</b>	<b>1328</b>
09/92→09/98	<b>164 3.0</b>	AR 64305	Petrol	2959	V6	<b>701</b>	<b>1327</b>
09/92→09/98	<b>164 3.0</b>	AR 64306	Petrol	2959	V6	<b>702</b>	<b>1324</b>
09/92→09/98	<b>164 3.0</b>	AR 64399	Petrol	2959	V6	<b>705</b>	<b>1324</b>
09/92→09/98	<b>164 3.0</b>	AR 66301	Petrol	2959	V6	<b>704</b>	<b>1324</b>
09/92→09/98	<b>164 3.0</b>	AR 66302	Petrol	2959	6	<b>704</b>	<b>1324</b>
09/92→09/98	<b>164 3.0</b>	AR 66303	Petrol	2959	V6	<b>701</b>	<b>1327</b>
11/92→09/98	<b>164 3.0</b>	AR 64307	Petrol	2959	V6	<b>703</b>	<b>1324</b>
02/94→09/98	<b>164 3.0</b>	AR 64308	Petrol	2959	V6	<b>704</b>	<b>1324</b>
03/95→10/97	<b>164 3.0</b>	AR 66306	Petrol	2959	V6	<b>706</b>	<b>1324</b>
09/98→10/00	<b>166 2.0</b>	AR 34102	Petrol	1996	V6	<b>160</b>	<b>901</b>
09/98→10/00	<b>166 2.0</b>	AR 34103	Petrol	1970	4	<b>349</b>	<b>1038</b>
10/00→06/07	<b>166 2.0</b>	AR 36301	Petrol	1970	4	<b>350</b>	<b>1040</b>
09/98→10/00	<b>166 2.4</b>	AR 34202	Diesel	2387	5	<b>290</b>	<b>973</b>
10/00→06/07	<b>166 2.4</b>	839 A6.000	Diesel	2387	5	<b>274</b>	<b>976</b>
04/02→06/07	<b>166 2.4</b>	841 C000	Diesel	2387	5	<b>277</b>	<b>976</b>
10/03→06/07	<b>166 2.4</b>	841 G.000	Diesel	2387	5	<b>278</b>	<b>978</b>
10/03→06/07	<b>166 2.4</b>	841 H.000	Diesel	2387	5	<b>281</b>	<b>980</b>
10/03→06/07	<b>166 2.4</b>	841 M.000	Diesel	2387	5	<b>282</b>	<b>978</b>
10/03→06/07	<b>166 2.4</b>	841 N.000	Diesel	2387	5		<b>984</b>
07/05→06/07	<b>166 2.4</b>	936 B.000	Diesel	2387	5	<b>285</b>	<b>986</b>
09/98→10/00	<b>166 2.5</b>	AR 34201	Petrol	2492	V6	<b>597</b>	<b>1242</b>
10/00→06/07	<b>166 2.5</b>	AR 36201	Petrol	2492	V6	<b>599</b>	<b>1242</b>
09/98→10/00	<b>166 3.0</b>	AR 34301	Petrol	2959	V6	<b>694</b>	<b>1323</b>
09/98→10/00	<b>166 3.0</b>	AR 34302	Petrol	2959	V6	<b>695</b>	<b>1324</b>
10/00→06/07	<b>166 3.0</b>	AR 36101	Petrol	2959	V6	<b>696</b>	<b>1323</b>
10/03→06/07	<b>166 3.2</b>	936 A.000	Petrol	3179	V6	<b>708</b>	
03/68→10/72	<b>1750-2000 1.8</b>	AR 00548	Petrol	1779	4	<b>152</b>	<b>898</b>
10/71→12/83	<b>1750-2000 2.0</b>	AR 10520	Petrol	1962	4	<b>424</b>	<b>1108</b>
01/67→12/83	<b>A11 / A12 PLATFORM/CHASSIS 1.3</b>	AR 00504	Petrol	1290	4		<b>833</b>
06/72→09/84	<b>ALFASUD 1.2</b>	AR 30102	Petrol	1186	4	<b>130</b>	<b>878</b>
11/73→09/84	<b>ALFASUD 1.2</b>	AR 30104	Petrol	1186	4	<b>131</b>	<b>880</b>
03/80→09/84	<b>ALFASUD 1.2</b>	AR 30102 S	Petrol	1186	4	<b>130</b>	<b>879</b>
09/77→09/84	<b>ALFASUD 1.3</b>	AR 30164	Petrol	1351	4	<b>136</b>	<b>880</b>
09/77→09/84	<b>ALFASUD 1.3</b>	AR 30184	Petrol	1286	4	<b>360</b>	<b>1048</b>
01/78→02/80	<b>ALFASUD 1.3</b>	AR 30180	Petrol	1286	4	<b>134</b>	<b>879</b>
01/79→09/84	<b>ALFASUD 1.3</b>	AR 30160	Petrol	1351	4	<b>131</b>	<b>878</b>
03/80→12/84	<b>ALFASUD 1.3</b>	AR 30168	Petrol	1351	4	<b>137</b>	<b>880</b>
01/79→09/84	<b>ALFASUD 1.5</b>	AR 30124	Petrol	1490	4	<b>361</b>	<b>1049</b>
03/80→12/84	<b>ALFASUD 1.5</b>	AR 30128	Petrol	1490	4	<b>361</b>	<b>1049</b>
01/83→12/84	<b>ALFASUD 1.5</b>	AR 30146	Petrol	1490	4	<b>363</b>	<b>1049</b>
01/78→12/81	<b>ALFASUD GIARDINETTA 1.2</b>	AR 30102	Petrol	1186	4	<b>130</b>	<b>878</b>
01/78→07/79	<b>ALFASUD GIARDINETTA 1.3</b>	AR 30180	Petrol	1286	4	<b>134</b>	<b>879</b>
03/80→12/81	<b>ALFASUD GIARDINETTA 1.3</b>	AR 30160	Petrol	1351	4	<b>131</b>	<b>878</b>
09/76→12/81	<b>ALFASUD SPRINT 1.3</b>	AR 30184	Petrol	1286	4	<b>360</b>	<b>1048</b>
05/78→02/80	<b>ALFASUD SPRINT 1.3</b>	AR 30164	Petrol	1351	4	<b>136</b>	<b>880</b>
07/79→12/89	<b>ALFASUD SPRINT 1.3</b>	AR 30168	Petrol	1351	4	<b>137</b>	<b>880</b>
05/78→12/81	<b>ALFASUD SPRINT 1.5</b>	AR 30124	Petrol	1490	4	<b>361</b>	<b>1049</b>
07/79→01/87	<b>ALFASUD SPRINT 1.5</b>	AR 30128	Petrol	1490	4	<b>361</b>	<b>1049</b>



ccm

X



9



01/80→12/87	<b>ALFASUD SPRINT 1.5</b>	AR 30146	Petrol	1490	4	<b>363</b>	<b>1049</b>
03/87→12/89	<b>ALFASUD SPRINT 1.7</b>	AR 30550	Petrol	1712	4	<b>563</b>	<b>1216</b>
10/87→12/89	<b>ALFASUD SPRINT 1.7</b>	AR 30558	Petrol	1712	4	<b>564</b>	<b>1217</b>
01/75→12/84	<b>ALFETTA 1.6</b>	AR 01600	Petrol	1570	4	<b>110</b>	<b>856</b>
07/74→12/77	<b>ALFETTA 1.8</b>	AR 01608 X	Petrol	1779	4	<b>155</b>	<b>898</b>
10/79→12/84	<b>ALFETTA 1.8</b>	AR 01608	Petrol	1779	4	<b>154</b>	<b>898</b>
10/79→12/84	<b>ALFETTA 1.8</b>	AR 01678	Petrol	1779	4	<b>154</b>	<b>898</b>
03/77→02/80	<b>ALFETTA 2.0</b>	AR 01623	Petrol	1962	4	<b>419</b>	<b>1102</b>
07/78→12/84	<b>ALFETTA 2.0</b>	AR 01655	Petrol	1962	4	<b>420</b>	<b>1103</b>
07/78→12/84	<b>ALFETTA 2.0</b>	AR 01713	Petrol	1962	4	<b>421</b>	<b>1098</b>
07/78→12/84	<b>ALFETTA 2.0</b>	AR 10520	Petrol	1962	4	<b>424</b>	<b>1108</b>
10/79→03/83	<b>ALFETTA 2.0</b>	VM4HT/2	Diesel	1995	4	<b>579</b>	<b>1228</b>
04/83→12/84	<b>ALFETTA 2.4</b>	VM4HT 2.4	Diesel	2393	4	<b>606</b>	<b>1246</b>
01/76→09/82	<b>ALFETTA GT 1.6</b>	AR 01600	Petrol	1570	4	<b>110</b>	<b>856</b>
01/74→12/76	<b>ALFETTA GT 1.8</b>	AR 01608	Petrol	1779	4	<b>154</b>	<b>898</b>
01/74→12/76	<b>ALFETTA GT 1.8</b>	AR 01608 X	Petrol	1779	4	<b>155</b>	<b>898</b>
06/77→12/84	<b>ALFETTA GT 2.0</b>	AR 01655	Petrol	1962	4	<b>420</b>	<b>1103</b>
07/78→01/86	<b>ALFETTA GT 2.0</b>	AR 01623	Petrol	1962	4	<b>419</b>	<b>1102</b>
04/85→12/89	<b>AR 6 BOX 1.9</b>	160 D100	Diesel	1929	4	<b>317</b>	<b>1008</b>
04/85→02/86	<b>AR 6 BOX 2.4</b>	8144.61.200	Diesel	2445	4	<b>630</b>	<b>1261</b>
09/86→12/89	<b>AR 6 BOX 2.4</b>	8144.21.220	Diesel	2445	4	<b>625</b>	<b>1253</b>
03/86→12/89	<b>AR 6 BOX 2.5</b>	8144.67.220	Diesel	2499	4	<b>666</b>	<b>1305</b>
04/85→12/89	<b>AR 6 BUS 1.9</b>	160 D100	Diesel	1929	4	<b>317</b>	<b>1008</b>
04/78→08/86	<b>AR 8 BOX 2.4</b>	8140.61.200	Diesel	2445	4	<b>619</b>	<b>1261</b>
04/85→12/89	<b>AR 8 BOX 2.4</b>	8140.21.200 D.I.	Diesel	2445	4	<b>615</b>	<b>1253</b>
09/86→12/89	<b>AR 8 BOX 2.5</b>	8144.67.220	Diesel	2499	4	<b>666</b>	<b>1305</b>
04/78→08/86	<b>AR 8 PLATFORM/CHASSIS 2.4</b>	8140.61.200	Diesel	2445	4	<b>619</b>	<b>1261</b>
04/85→12/88	<b>AR 8 PLATFORM/CHASSIS 2.4</b>	8140.21.200 D.I.	Diesel	2445	4	<b>615</b>	<b>1253</b>
09/86→12/89	<b>AR 8 PLATFORM/CHASSIS 2.5</b>	8144.67.220	Diesel	2499	4	<b>666</b>	<b>1305</b>
03/83→12/86	<b>ARNA 1.2</b>	AR 30102	Petrol	1186	4	<b>130</b>	<b>878</b>
01/85→12/86	<b>ARNA 1.2</b>	AR 30500	Petrol	1186	4	<b>130</b>	<b>881</b>
01/85→12/86	<b>ARNA 1.2</b>	AR 31000	Petrol	1186	4	<b>133</b>	<b>878</b>
03/83→12/86	<b>ARNA 1.3</b>	AR 30168	Petrol	1351	4	<b>137</b>	<b>880</b>
03/83→12/86	<b>ARNA 1.3</b>	AR 31010	Petrol	1351	4	<b>141</b>	<b>878</b>
01/85→12/86	<b>ARNA 1.3</b>	AR 30100	Petrol	1351	4	<b>135</b>	<b>884</b>
01/85→12/86	<b>ARNA 1.5</b>	AR 30182	Petrol	1490	4	<b>364</b>	<b>1049</b>
05/09→	<b>BRERA 1.8</b>	939 B1.000	Petrol	1742	4	<b>329</b>	<b>1019</b>
03/08→	<b>BRERA 2.0</b>	844 A2.000	Diesel	1956	4		<b>1034</b>
05/09→	<b>BRERA 2.0</b>	939 B3.000	Diesel	1956	4	<b>341</b>	<b>1032</b>
01/06→	<b>BRERA 2.2</b>	939 A5.000	Petrol	2198	4	<b>518</b>	<b>1174</b>
01/06→	<b>BRERA 2.4</b>	939 A3.000	Diesel	2387	5	<b>287</b>	<b>988</b>
05/07→	<b>BRERA 2.4</b>	939 A9.000	Diesel	2387	5	<b>288</b>	<b>989</b>
01/06→	<b>BRERA 3.2</b>	939 A.000	Petrol	3196	V6	<b>573</b>	
01/67→12/83	<b>F11 / F12 BOX 1.3</b>	AR 00504	Petrol	1290	4		<b>833</b>
01/67→12/83	<b>F11 / F12 BUS 1.3</b>	AR 00504	Petrol	1290	4		<b>833</b>
01/64→08/69	<b>GIULIA 1.3</b>	AR 00506	Petrol	1290	4		<b>834</b>
01/74→12/78	<b>GIULIA 1.3</b>	AR 00530	Petrol	1290	4	<b>84</b>	<b>835</b>
01/63→12/78	<b>GIULIA 1.6</b>	AR 00516	Petrol	1570	4		<b>855</b>
06/64→12/78	<b>GIULIA 1.6</b>	AR 00526	Petrol	1570	4	<b>108</b>	<b>856</b>
06/76→12/78	<b>GIULIA 1.8</b>	4.108	Diesel	1760	4	<b>115</b>	<b>863</b>
01/74→12/78	<b>GIULIA GT 1.3</b>	AR 00530	Petrol	1290	4	<b>84</b>	<b>835</b>
01/62→12/64	<b>GIULIA GT 1.6</b>	AR 00112	Petrol	1570	4		<b>855</b>
01/63→12/65	<b>GIULIA GT 1.6</b>	AR 00121	Petrol	1570	4		<b>855</b>
01/74→12/78	<b>GIULIA GT 1.6</b>	AR 00526	Petrol	1570	4	<b>108</b>	<b>856</b>
03/62→12/66	<b>GIULIA SPIDER 1.6</b>	AR 00112	Petrol	1570	4		<b>855</b>
03/62→12/66	<b>GIULIA SPIDER 1.6</b>	AR 00121	Petrol	1570	4		<b>855</b>
10/77→06/83	<b>GIULIETTA 1.3</b>	AR 01644	Petrol	1357	4	<b>142</b>	<b>886</b>
04/10→	<b>GIULIETTA 1.4</b>	198 A4.000	Petrol	1368	4	<b>68</b>	<b>815</b>
04/10→	<b>GIULIETTA 1.4</b>	940 A2.000	Petrol	1368	4	<b>78</b>	<b>820</b>
04/10→	<b>GIULIETTA 1.4</b>	940 A6.000	Petrol	1368	4	<b>79</b>	<b>827</b>
04/10→	<b>GIULIETTA 1.4</b>	955 A8.000	Petrol	1368	4	<b>78</b>	<b>820</b>
04/11→	<b>GIULIETTA 1.4</b>	940 B1.000	Petrol	1368	4	<b>80</b>	<b>828</b>
10/77→04/85	<b>GIULIETTA 1.6</b>	AR 01600	Petrol	1570	4	<b>110</b>	<b>856</b>
04/10→	<b>GIULIETTA 1.6</b>	940 A3.000	Diesel	1598	4	<b>116</b>	<b>869</b>
04/79→04/85	<b>GIULIETTA 1.8</b>	AR 01678	Petrol	1779	4	<b>154</b>	<b>898</b>
01/84→12/85	<b>GIULIETTA 1.8</b>	AR 01354	Petrol	1779	4	<b>153</b>	<b>899</b>
04/10→	<b>GIULIETTA 1.8</b>	940 A1.000	Petrol	1742	4	<b>329</b>	<b>1020</b>
06/80→04/85	<b>GIULIETTA 2.0</b>	AR 01655	Petrol	1962	4	<b>420</b>	<b>1103</b>
06/80→04/85	<b>GIULIETTA 2.0</b>	AR 11671	Petrol	1962	4	<b>425</b>	<b>1102</b>
01/83→12/85	<b>GIULIETTA 2.0</b>	VM 4 HT	Diesel	1995	4	<b>578</b>	<b>1227</b>
07/83→06/84	<b>GIULIETTA 2.0</b>	AR 01699	Petrol	1962	4		<b>1104</b>
04/10→	<b>GIULIETTA 2.0</b>	940 A4.000	Diesel	1956	4	<b>341</b>	<b>1030</b>



ccm

X



9



04/10→	<b>GIULIETTA 2.0</b>	940 A5.000	Diesel	1956	4	<b>340</b>	<b>1035</b>
04/10→	<b>GIULIETTA 2.0</b>	940 A7.000	Diesel	1956	4		<b>1035</b>
04/10→	<b>GIULIETTA 2.0</b>	940 A8.000	Diesel	1956	4		<b>1035</b>
01/55→12/57	<b>GIULIETTA BERLINA 1.3</b>	AR 00500	Petrol	1290	4		<b>833</b>
01/57→12/62	<b>GIULIETTA BERLINA 1.3</b>	AR 00502	Petrol	1290	4		<b>833</b>
01/58→12/60	<b>GIULIETTA BERLINA 1.3</b>	AR 00504	Petrol	1290	4		<b>833</b>
01/58→12/61	<b>GIULIETTA COUPE 1.3</b>	AR 00514	Petrol	1290	4		<b>833</b>
01/57→12/62	<b>GIULIETTA ESTATE 1.3</b>	AR 00500	Petrol	1290	4		<b>833</b>
01/59→12/62	<b>GIULIETTA ESTATE 1.3</b>	AR 00504	Petrol	1290	4		<b>833</b>
01/55→12/62	<b>GIULIETTA SPIDER 1.3</b>	AR 00501	Petrol	1290	4		<b>833</b>
01/56→12/62	<b>GIULIETTA SPIDER 1.3</b>	AR 00510	Petrol	1290	4		<b>833</b>
01/61→12/62	<b>GIULIETTA SPIDER 1.3</b>	AR 00508	Petrol	1290	4		<b>833</b>
01/54→12/62	<b>GIULIETTA SPRINT 1.3</b>	AR 00501	Petrol	1290	4		<b>833</b>
01/56→12/62	<b>GIULIETTA SPRINT 1.3</b>	AR 00510	Petrol	1290	4		<b>833</b>
01/58→12/61	<b>GIULIETTA SPRINT SPECIALE 1.3</b>	AR 00514	Petrol	1290	4		<b>833</b>
01/66→12/77	<b>GT 1.3</b>	AR 00530	Petrol	1290	4	<b>84</b>	<b>835</b>
03/63→12/77	<b>GT 1.6</b>	AR 00526 S	Petrol	1570	4		<b>857</b>
01/65→12/70	<b>GT 1.6</b>	AR 10538	Petrol	1570	4		<b>861</b>
01/66→12/77	<b>GT 1.6</b>	AR 00536	Petrol	1570	4	<b>109</b>	<b>856</b>
01/67→12/72	<b>GT 1.8</b>	AR 00548	Petrol	1779	4	<b>152</b>	<b>898</b>
11/03→09/10	<b>GT 1.8</b>	AR 32205	Petrol	1747	4	<b>204</b>	<b>933</b>
01/71→12/77	<b>GT 1.9</b>	AR 10527	Petrol	1962	4	<b>425</b>	<b>1098</b>
11/03→09/10	<b>GT 1.9</b>	937 A5.000	Diesel	1910	4	<b>241</b>	<b>946</b>
05/08→09/10	<b>GT 1.9</b>	937 A6.000	Diesel	1910	4	<b>242</b>	<b>956</b>
11/03→09/10	<b>GT 2.0</b>	932 A2.000	Petrol	1970	4	<b>343</b>	<b>1036</b>
11/03→09/10	<b>GT 2.0</b>	937 A1.000	Petrol	1970	4	<b>344</b>	<b>1037</b>
11/03→09/10	<b>GT 3.2</b>	936 A.000	Petrol	3179	V6	<b>708</b>	
05/68→12/76	<b>GTA COUPE 1.3</b>	AR 10531	Petrol	1290	4		<b>836</b>
05/68→12/76	<b>GTA COUPE 1.3</b>	AR 10534	Petrol	1290	4		<b>836</b>
05/98→10/05	<b>GTV 1.7</b>	AR 32201	Petrol	1747	4	<b>203</b>	<b>933</b>
01/78→12/80	<b>GTV 2.0</b>	AR 11642	Petrol	1962	4	<b>426</b>	<b>1104</b>
07/78→01/86	<b>GTV 2.0</b>	AR 01655	Petrol	1962	4	<b>420</b>	<b>1103</b>
07/78→01/86	<b>GTV 2.0</b>	AR 06212	Petrol	1962	4	<b>421</b>	<b>1103</b>
06/95→09/98	<b>GTV 2.0</b>	AR 16202	Petrol	1996	V6	<b>159</b>	<b>901</b>
06/95→10/05	<b>GTV 2.0</b>	AR 16201	Petrol	1970	4	<b>345</b>	<b>1038</b>
06/95→10/05	<b>GTV 2.0</b>	AR 32310	Petrol	1970	4	<b>348</b>	<b>1040</b>
05/98→08/00	<b>GTV 2.0</b>	AR 32301	Petrol	1970	4	<b>346</b>	<b>1038</b>
04/03→10/05	<b>GTV 2.0</b>	937 A1.000	Petrol	1970	4	<b>344</b>	<b>1037</b>
11/80→02/87	<b>GTV 2.5</b>	AR 01646	Petrol	2492	V6	<b>593</b>	<b>1238</b>
10/96→10/00	<b>GTV 3.0</b>	AR 16102	Petrol	2959	V6	<b>692</b>	<b>1323</b>
10/00→10/05	<b>GTV 3.0</b>	AR 16105	Petrol	2959	V6	<b>693</b>	<b>1323</b>
04/03→10/05	<b>GTV 3.2</b>	936 A6.000	Petrol	3179	V6	<b>709</b>	
07/11→	<b>MITO 0.9</b>	312 A2.000	Petrol	875	2		<b>921</b>
04/13→	<b>MITO 0.9</b>	199 B6.000	Petrol	875	2		<b>920</b>
09/08→	<b>MITO 1.3</b>	199 A3.000	Diesel	1248	4	<b>27</b>	<b>779</b>
10/09→	<b>MITO 1.3</b>	199 B1.000	Diesel	1248	4	<b>30</b>	<b>780</b>
01/11→	<b>MITO 1.3</b>	199 B4.000	Diesel	1248	4	<b>31</b>	<b>782</b>
09/08→	<b>MITO 1.4</b>	198 A1.000	Petrol	1368	4	<b>68</b>	<b>815</b>
09/08→	<b>MITO 1.4</b>	198 A4.000	Petrol	1368	4	<b>68</b>	<b>815</b>
09/08→	<b>MITO 1.4</b>	199 A6.000	Petrol	1368	4	<b>72</b>	<b>818</b>
09/08→	<b>MITO 1.4</b>	199 A8.000	Petrol	1368	4	<b>70</b>	<b>815</b>
09/08→	<b>MITO 1.4</b>	955 A1.000	Petrol	1368	4	<b>79</b>	<b>813</b>
10/09→	<b>MITO 1.4</b>	940 A2.000	Petrol	1368	4	<b>78</b>	<b>820</b>
10/09→	<b>MITO 1.4</b>	955 A2.000	Petrol	1368	4	<b>78</b>	<b>821</b>
10/09→	<b>MITO 1.4</b>	955 A7.000	Petrol	1368	4	<b>78</b>	<b>820</b>
10/09→	<b>MITO 1.4</b>	955 A8.000	Petrol	1368	4	<b>78</b>	<b>820</b>
08/10→	<b>MITO 1.4</b>	955 A6.000	Petrol	1368	4	<b>81</b>	<b>821</b>
03/11→	<b>MITO 1.4</b>	350 A1.000	Petrol	1368	4	<b>74</b>	<b>825</b>
05/11→	<b>MITO 1.4</b>	955 A9.000	Petrol	1368	4	<b>82</b>	<b>829</b>
09/08→	<b>MITO 1.6</b>	198 A2.000	Diesel	1598	4	<b>116</b>	<b>864</b>
09/08→	<b>MITO 1.6</b>	955 A3.000	Diesel	1598	4	<b>116</b>	<b>864</b>
09/08→	<b>MITO 1.6</b>	955 A4.000	Diesel	1598	4	<b>116</b>	<b>869</b>
01/92→12/94	<b>RZ 3.0</b>	AR 61501	Petrol	2959	V6	<b>697</b>	<b>1324</b>
01/68→12/77	<b>SPIDER 1.3</b>	AR 00530	Petrol	1290	4	<b>84</b>	<b>835</b>
03/66→12/90	<b>SPIDER 1.6</b>	AR 00526	Petrol	1570	4	<b>108</b>	<b>856</b>
03/66→12/79	<b>SPIDER 1.6</b>	AR 00536	Petrol	1570	4	<b>109</b>	<b>856</b>
03/66→12/68	<b>SPIDER 1.6</b>	AR 01600	Petrol	1570	4	<b>110</b>	<b>856</b>
01/90→12/93	<b>SPIDER 1.6</b>	AR 01563	Petrol	1570	4	<b>113</b>	<b>860</b>
05/98→04/05	<b>SPIDER 1.7</b>	AR 32201	Petrol	1747	4	<b>203</b>	<b>933</b>
01/67→12/71	<b>SPIDER 1.8</b>	AR 00548	Petrol	1779	4	<b>152</b>	<b>898</b>
05/09→	<b>SPIDER 1.8</b>	939 B1.000	Petrol	1742	4	<b>329</b>	<b>1019</b>
01/71→12/77	<b>SPIDER 2.0</b>	AR 00512	Petrol	1962	4	<b>414</b>	<b>1097</b>

Modelverzeichnis • Indice modello • Index de modèle • Índice de Modelo  
Indeks modelu • Модель автомобиля • دليل الموديل

# MODEL INDEX



ccm

X



9



01/74→12/84	<b>SPIDER 2.0</b>	AR 01615	Petrol	1962	4		<b>1098</b>
01/77→12/93	<b>SPIDER 2.0</b>	AR 00515	Petrol	1962	4	<b>415</b>	<b>1098</b>
01/77→12/93	<b>SPIDER 2.0</b>	AR 01590	Petrol	1962	4	<b>418</b>	<b>1098</b>
08/86→12/90	<b>SPIDER 2.0</b>	AR 01544	Petrol	1962	4	<b>416</b>	<b>1100</b>
01/90→12/93	<b>SPIDER 2.0</b>	AR 01588	Petrol	1962	4	<b>417</b>	<b>1101</b>
06/95→04/05	<b>SPIDER 2.0</b>	AR 16201	Petrol	1970	4	<b>345</b>	<b>1038</b>
06/95→04/05	<b>SPIDER 2.0</b>	AR 32310	Petrol	1970	4	<b>348</b>	<b>1040</b>
05/98→08/00	<b>SPIDER 2.0</b>	AR 32301	Petrol	1970	4	<b>346</b>	<b>1038</b>
05/98→04/05	<b>SPIDER 2.0</b>	AR 16202	Petrol	1996	V6	<b>159</b>	<b>901</b>
04/03→04/05	<b>SPIDER 2.0</b>	937 A1.000	Petrol	1970	4	<b>344</b>	<b>1037</b>
04/09→	<b>SPIDER 2.0</b>	844 A2.000	Diesel	1956	4		<b>1034</b>
05/09→	<b>SPIDER 2.0</b>	939 B3.000	Diesel	1956	4	<b>341</b>	<b>1032</b>
09/06→	<b>SPIDER 2.2</b>	939 A5.000	Petrol	2198	4	<b>518</b>	<b>1174</b>
04/07→	<b>SPIDER 2.4</b>	939 A3.000	Diesel	2387	5	<b>287</b>	<b>988</b>
09/94→08/00	<b>SPIDER 3.0</b>	AR 16105	Petrol	2959	V6	<b>693</b>	<b>1323</b>
06/95→04/05	<b>SPIDER 3.0</b>	AR 16101	Petrol	2959	V6	<b>691</b>	<b>1327</b>
01/99→10/03	<b>SPIDER 3.0</b>	AR 16102	Petrol	2959	V6	<b>692</b>	<b>1323</b>
04/03→04/05	<b>SPIDER 3.2</b>	936 A6.000	Petrol	3179	V6	<b>709</b>	
09/06→	<b>SPIDER 3.2</b>	939 A.000	Petrol	3196	V6	<b>573</b>	
09/88→08/94	<b>SZ 3.0</b>	AR 61501	Petrol	2959	V6	<b>697</b>	<b>1324</b>



ccm

X



9



12/68→07/75	<b>124 1.4</b>	124 B2.000	Petrol	1438	4	<b>144</b>	<b>888</b>
01/71→07/75	<b>124 1.4</b>	124 AC.000	Petrol	1438	4	<b>143</b>	<b>887</b>
06/67→10/72	<b>124 COUPE 1.4</b>	124 AC.000	Petrol	1438	4	<b>143</b>	<b>887</b>
08/72→12/75	<b>124 COUPE 1.6</b>	132 AC.000	Petrol	1592	4	<b>148</b>	<b>895</b>
01/66→12/72	<b>124 SPIDER 1.4</b>	124 AC.000	Petrol	1438	4	<b>143</b>	<b>887</b>
01/69→12/74	<b>124 SPIDER 1.6</b>	132 AC.000	Petrol	1592	4	<b>148</b>	<b>895</b>
01/72→12/77	<b>124 SPIDER 1.8</b>	132 AC1.000	Petrol	1756	4	<b>394</b>	<b>1076</b>
03/82→11/85	<b>124 SPIDER 2.0</b>	132 C3.031	Petrol	1995	4	<b>432</b>	<b>1113</b>
07/67→03/74	<b>125 1.6</b>	125 A.000	Petrol	1608	4	<b>150</b>	<b>897</b>
05/69→10/73	<b>125 1.6</b>	125 B.000	Petrol	1608	4	<b>151</b>	<b>897</b>
09/72→06/77	<b>126 0.6</b>	126 A.000	Petrol	594	2	<b>83</b>	<b>831</b>
07/77→09/87	<b>126 0.6</b>	126 A1.000	Petrol	652	2	<b>102</b>	<b>850</b>
07/77→09/00	<b>126 0.7</b>	126 A1.048	Petrol	652	2	<b>102</b>	<b>850</b>
09/87→06/96	<b>126 0.7</b>	126 A2.000	Petrol	704	2	<b>164</b>	<b>904</b>
09/87→06/96	<b>126 0.7</b>	126 A2.048	Petrol	704	2	<b>164</b>	<b>904</b>
06/71→05/83	<b>127 0.9</b>	100 GL.000	Petrol	903	4	<b>8</b>	<b>758</b>
06/71→05/83	<b>127 0.9</b>	100 GL.048	Petrol	903	4	<b>9</b>	<b>751</b>
04/77→12/86	<b>127 1.0</b>	127 A.000	Petrol	1049	4	<b>88</b>	<b>839</b>
07/78→02/82	<b>127 1.0</b>	127 A1.000	Petrol	1049	4	<b>89</b>	<b>840</b>
04/81→12/86	<b>127 1.3</b>	127 A5.000	Diesel	1302	4	<b>95</b>	<b>846</b>
12/81→05/83	<b>127 1.3</b>	127 A3.000	Petrol	1301	4	<b>100</b>	<b>844</b>
01/77→12/86	<b>127 PANORAMA 1.0</b>	127 A.000	Petrol	1049	4	<b>88</b>	<b>839</b>
06/81→12/86	<b>127 PANORAMA 1.3</b>	127 A5.000	Diesel	1302	4	<b>95</b>	<b>846</b>
03/69→12/84	<b>128 1.1</b>	128 A.000	Petrol	1116	4	<b>118</b>	<b>871</b>
02/75→09/81	<b>128 1.1</b>	128 A.048	Petrol	1116	4	<b>119</b>	<b>871</b>
09/71→02/76	<b>128 1.3</b>	128 AR.000	Petrol	1290	4		<b>1173</b>
08/74→12/84	<b>128 1.3</b>	128 A1.000	Petrol	1290	4	<b>506</b>	<b>1172</b>
03/72→02/81	<b>128 COUPE 1.1</b>	128 AC5.000	Petrol	1116	4	<b>120</b>	<b>872</b>
03/72→12/79	<b>128 COUPE 1.3</b>	128 AC.000	Petrol	1290	4	<b>506</b>	<b>1172</b>
10/69→10/82	<b>128 FAMILIARE 1.1</b>	128 A.000	Petrol	1116	4	<b>118</b>	<b>871</b>
02/75→02/81	<b>128 FAMILIARE 1.1</b>	128 A.048	Petrol	1116	4	<b>119</b>	<b>871</b>
12/74→10/82	<b>128 FAMILIARE 1.3</b>	128 A1.000	Petrol	1290	4	<b>506</b>	<b>1172</b>
10/74→09/81	<b>131 1.3</b>	131 A6.000	Petrol	1297	4	<b>92</b>	<b>843</b>
10/74→12/82	<b>131 1.3</b>	131 A.000	Petrol	1297	4		<b>842</b>
03/78→12/80	<b>131 1.3</b>	131 B.000	Petrol	1297	4		<b>843</b>
11/80→01/84	<b>131 1.4</b>	131 C.000	Petrol	1367	4	<b>104</b>	<b>852</b>
11/80→01/84	<b>131 1.4</b>	131 C1.000	Petrol	1367	4	<b>105</b>	<b>852</b>
10/74→09/81	<b>131 1.6</b>	131 A1.000	Petrol	1585	4	<b>372</b>	<b>1056</b>
11/76→12/84	<b>131 1.6</b>	131 C2.000	Petrol	1585	4	<b>374</b>	<b>1059</b>
03/78→01/84	<b>131 1.6</b>	131 C3.000	Petrol	1585	4	<b>375</b>	<b>1060</b>
03/79→03/82	<b>131 1.6</b>	131 B1.000	Petrol	1585	4	<b>373</b>	<b>1058</b>
01/76→12/81	<b>131 2.0</b>	131 B2.000	Petrol	1995	4	<b>427</b>	<b>1109</b>
07/78→08/84	<b>131 2.0</b>	8144.65	Diesel	1995	4	<b>577</b>	<b>1226</b>
01/81→12/84	<b>131 2.0</b>	131 C4.000	Petrol	1995	4	<b>428</b>	<b>1110</b>
06/78→02/84	<b>131 2.4</b>	8144.61	Diesel	2428	4	<b>612</b>	<b>1250</b>
03/75→12/78	<b>131 FAMILIARE/PANORAMA 1.3</b>	131 A6.000	Petrol	1297	4	<b>92</b>	<b>843</b>
03/75→03/82	<b>131 FAMILIARE/PANORAMA 1.3</b>	131 A.000	Petrol	1297	4		<b>842</b>
11/81→01/84	<b>131 FAMILIARE/PANORAMA 1.4</b>	131 C.000	Petrol	1367	4	<b>104</b>	<b>852</b>
11/81→01/84	<b>131 FAMILIARE/PANORAMA 1.4</b>	131 C1.000	Petrol	1367	4	<b>105</b>	<b>852</b>
03/75→12/78	<b>131 FAMILIARE/PANORAMA 1.6</b>	131 A1.000	Petrol	1585	4	<b>372</b>	<b>1056</b>
12/79→12/81	<b>131 FAMILIARE/PANORAMA 1.6</b>	131 C3.000	Petrol	1585	4	<b>375</b>	<b>1060</b>
11/80→04/85	<b>131 FAMILIARE/PANORAMA 1.6</b>	131 C2.000	Petrol	1585	4	<b>374</b>	<b>1059</b>
07/78→08/84	<b>131 FAMILIARE/PANORAMA 2.0</b>	8144.65	Diesel	1995	4	<b>577</b>	<b>1226</b>
01/81→12/84	<b>131 FAMILIARE/PANORAMA 2.0</b>	131 C4.000	Petrol	1995	4	<b>428</b>	<b>1110</b>
03/79→12/84	<b>131 FAMILIARE/PANORAMA 2.4</b>	8144.61	Diesel	2428	4	<b>612</b>	<b>1250</b>
04/72→01/76	<b>132 1.6</b>	132 BB OA O	Petrol	1592	4	<b>149</b>	<b>896</b>
01/76→12/82	<b>132 1.6</b>	132 C.000	Petrol	1585	4	<b>376</b>	<b>1058</b>
03/77→12/81	<b>132 1.6</b>	132 C6.000	Petrol	1585	4	<b>377</b>	<b>1061</b>
04/72→01/77	<b>132 1.7</b>	132 B1.000	Petrol	1756	4	<b>396</b>	<b>1079</b>
05/77→06/81	<b>132 2.0</b>	132 C2.000	Petrol	1995	4	<b>430</b>	<b>1112</b>
07/78→07/82	<b>132 2.0</b>	8144.65	Diesel	1995	4	<b>577</b>	<b>1226</b>
01/80→12/82	<b>132 2.0</b>	132 C3.000	Petrol	1995	4	<b>431</b>	<b>1112</b>
07/78→07/82	<b>132 2.4</b>	8144.61	Diesel	2428	4	<b>612</b>	<b>1250</b>
10/76→12/95	<b>147 1.0</b>	127 A.000	Petrol	1049	4	<b>88</b>	<b>839</b>
07/82→06/84	<b>147 1.3</b>	127 A5.000	Diesel	1302	4	<b>95</b>	<b>846</b>
09/66→06/82	<b>238-SERIE 1.4</b>	131 AZ.000	Petrol	1440	4		<b>890</b>
06/76→06/82	<b>238-SERIE 1.4</b>	131 BZ OCO	Petrol	1440	4		<b>890</b>
06/76→06/82	<b>238-SERIE 1.4</b>	131 FZ	Petrol	1440	4		<b>890</b>
10/75→07/82	<b>242-SERIE BOX 1.6</b>	124 B3.000	Petrol	1585	4	<b>371</b>	<b>1055</b>
10/75→07/82	<b>242-SERIE BOX 1.9</b>	132 AZ2.000	Petrol	1995	4	<b>429</b>	<b>1061</b>
08/80→07/82	<b>242-SERIE BOX 2.5</b>	B 25.637	Diesel	2498	4		<b>1273</b>
10/75→07/82	<b>242-SERIE BUS 1.6</b>	124 B3.000	Petrol	1585	4	<b>371</b>	<b>1055</b>



ccm

x



9



10/75→07/82	<b>242-SERIE BUS 1.9</b>	132 A22.000	Petrol	1995	4	<b>429</b>	<b>1061</b>
	<b>400 SERIE</b>	8035.01	Diesel	2338	3		<b>1347</b>
01/65→12/75	<b>500 0.5</b>	110 F.000	Petrol	499	2	<b>21</b>	<b>772</b>
01/65→12/75	<b>500 0.5</b>	120.000	Petrol	499	2	<b>21</b>	<b>772</b>
07/10→	<b>500 0.9</b>	312 A2.000	Petrol	875	2		<b>922</b>
10/13→	<b>500 0.9</b>	199 B6.000	Petrol	875	2		<b>920</b>
10/07→	<b>500 1.2</b>	169 A1.000	Diesel	1248	4	<b>22</b>	<b>773</b>
10/07→	<b>500 1.2</b>	169 A4.000	Petrol	1242	4	<b>45</b>	<b>797</b>
12/09→	<b>500 1.3</b>	199 B1.000	Diesel	1248	4	<b>30</b>	<b>780</b>
10/07→	<b>500 1.4</b>	169 A3.000	Petrol	1368	4	<b>65</b>	<b>813</b>
08/08→	<b>500 1.4</b>	312 A1.000	Petrol	1368	4	<b>75</b>	<b>821</b>
08/08→	<b>500 1.4</b>	312 A3.000	Petrol	1368	4	<b>68</b>	<b>822</b>
09/09→	<b>500 C 0.9</b>	312 A2.000	Petrol	875	2		<b>922</b>
12/13→	<b>500 C 0.9</b>	199 B6.000	Petrol	875	2		<b>920</b>
09/09→	<b>500 C 1.2</b>	169 A1.000	Diesel	1248	4	<b>22</b>	<b>773</b>
09/09→	<b>500 C 1.2</b>	169 A4.000	Petrol	1242	4	<b>45</b>	<b>797</b>
09/09→	<b>500 C 1.3</b>	199 B1.000	Diesel	1248	4	<b>30</b>	<b>780</b>
09/09→	<b>500 C 1.4</b>	169 A3.000	Petrol	1368	4	<b>65</b>	<b>813</b>
09/09→	<b>500 C 1.4</b>	312 A3.000	Petrol	1368	4	<b>68</b>	<b>822</b>
01/11→	<b>500 C 1.4</b>	312 A1.000	Petrol	1368	4	<b>75</b>	<b>821</b>
01/60→12/66	<b>500 ESTATE 0.5</b>	120.000	Petrol	499	2	<b>21</b>	<b>772</b>
09/12→	<b>500L 0.9</b>	199 B6.000	Petrol	875	2		<b>920</b>
03/13→	<b>500L 0.9</b>	312 A2.000	Petrol	875	2		<b>922</b>
09/12→	<b>500L 1.3</b>	199 B4.000	Diesel	1248	4	<b>32</b>	<b>782</b>
09/12→	<b>500L 1.4</b>	843 A1.000	Petrol	1368	4	<b>77</b>	<b>818</b>
09/12→	<b>500L 1.6</b>	199 B5.000	Diesel	1598	4	<b>117</b>	
09/13→	<b>500L 1.6</b>	955 A3.000	Diesel	1598	4	<b>116</b>	<b>864</b>
07/64→10/72	<b>850 0.8</b>	100 G.000	Petrol	843	4	<b>4</b>	<b>751</b>
07/64→10/72	<b>850 0.8</b>	100 G.002	Petrol	843	4	<b>4</b>	<b>752</b>
03/68→10/72	<b>850 0.8</b>	100 GB.000	Petrol	843	4	<b>4</b>	<b>753</b>
02/68→10/72	<b>850 COUPE 0.9</b>	100 GL.040	Petrol	903	4		<b>759</b>
03/68→12/72	<b>850 SPIDER 0.9</b>	100 GL.040	Petrol	903	4		<b>759</b>
01/78→01/86	<b>900 T/E PANORAMA 0.9</b>	100 GF.000	Petrol	903	4	<b>8</b>	<b>758</b>
01/78→01/86	<b>900 T/E PULMINO 0.9</b>	100 GF.000	Petrol	903	4	<b>8</b>	<b>758</b>
04/81→12/85	<b>ARGENTA 1.6</b>	132 D.000	Petrol	1585	4	<b>378</b>	<b>1058</b>
06/78→12/85	<b>ARGENTA 2.0</b>	132 C2.000	Petrol	1995	4	<b>430</b>	<b>1112</b>
06/78→12/85	<b>ARGENTA 2.0</b>	132 D1.000	Petrol	1995	4	<b>430</b>	<b>1112</b>
06/81→07/86	<b>ARGENTA 2.0</b>	132 C3.000	Petrol	1995	4	<b>431</b>	<b>1112</b>
06/81→11/85	<b>ARGENTA 2.4</b>	8144.61	Diesel	2428	4	<b>612</b>	<b>1250</b>
07/83→08/85	<b>ARGENTA 2.4</b>	8144.61.500.81	Diesel	2445	4	<b>631</b>	<b>1270</b>
04/95→05/05	<b>BARCHETTA 1.8</b>	183 A1.000	Petrol	1747	4	<b>197</b>	<b>929</b>
04/95→05/05	<b>BARCHETTA 1.8</b>	188 A6.000	Petrol	1747	4	<b>198</b>	<b>931</b>
12/98→12/02	<b>BRAVA 1.2</b>	182 B2.000	Petrol	1242	4	<b>57</b>	<b>807</b>
10/00→10/01	<b>BRAVA 1.2</b>	188 A5.000	Petrol	1242	4	<b>60</b>	<b>810</b>
10/95→08/98	<b>BRAVA 1.4</b>	182 A3.000	Petrol	1370	4	<b>184</b>	<b>923</b>
10/95→10/01	<b>BRAVA 1.4</b>	182 A5.000	Petrol	1370	4	<b>185</b>	<b>923</b>
10/95→10/01	<b>BRAVA 1.6</b>	182 A6.000	Petrol	1581	4	<b>553</b>	<b>1210</b>
02/96→10/01	<b>BRAVA 1.6</b>	182 A4.000	Petrol	1581	4	<b>551</b>	<b>1208</b>
01/99→12/02	<b>BRAVA 1.6</b>	182 B6.000	Petrol	1596	4	<b>181</b>	<b>916</b>
10/95→10/01	<b>BRAVA 1.8</b>	182 A2.000	Petrol	1747	4	<b>194</b>	<b>929</b>
10/95→10/01	<b>BRAVA 1.9</b>	160 A7.000	Diesel	1929	4	<b>313</b>	<b>1001</b>
03/96→10/01	<b>BRAVA 1.9</b>	182 A7.000	Diesel	1910	4	<b>208</b>	<b>936</b>
03/96→10/01	<b>BRAVA 1.9</b>	182 A8.000	Diesel	1910	4	<b>209</b>	<b>936</b>
12/98→12/02	<b>BRAVA 1.9</b>	182 B4.000	Diesel	1910	4	<b>210</b>	<b>937</b>
09/00→10/01	<b>BRAVA 1.9</b>	182 B9.000	Diesel	1910	4	<b>211</b>	<b>939</b>
09/98→08/00	<b>BRAVA 2.0</b>	182 B7.000	Petrol	1998	5	<b>262</b>	<b>968</b>
12/98→10/01	<b>BRAVO I 1.2</b>	182 B2.000	Petrol	1242	4	<b>57</b>	<b>807</b>
10/00→10/01	<b>BRAVO I 1.2</b>	188 A5.000	Petrol	1242	4	<b>60</b>	<b>810</b>
10/95→10/01	<b>BRAVO I 1.4</b>	182 A3.000	Petrol	1370	4	<b>184</b>	<b>923</b>
10/95→10/01	<b>BRAVO I 1.4</b>	182 A5.000	Petrol	1370	4	<b>185</b>	<b>923</b>
10/95→10/01	<b>BRAVO I 1.6</b>	182 A6.000	Petrol	1581	4	<b>553</b>	<b>1210</b>
03/96→10/01	<b>BRAVO I 1.6</b>	182 A4.000	Petrol	1581	4	<b>551</b>	<b>1208</b>
09/00→02/02	<b>BRAVO I 1.6</b>	182 B6.000	Petrol	1596	4	<b>181</b>	<b>916</b>
10/95→10/01	<b>BRAVO I 1.8</b>	182 A2.000	Petrol	1747	4	<b>194</b>	<b>929</b>
10/95→10/01	<b>BRAVO I 1.9</b>	160 A7.000	Diesel	1929	4	<b>313</b>	<b>1001</b>
03/96→10/01	<b>BRAVO I 1.9</b>	182 A7.000	Diesel	1910	4	<b>208</b>	<b>936</b>
03/96→10/01	<b>BRAVO I 1.9</b>	182 A8.000	Diesel	1910	4	<b>209</b>	<b>936</b>
12/98→10/01	<b>BRAVO I 1.9</b>	182 B4.000	Diesel	1910	4	<b>210</b>	<b>937</b>
09/00→10/01	<b>BRAVO I 1.9</b>	182 B9.000	Diesel	1910	4	<b>211</b>	<b>939</b>
10/95→07/98	<b>BRAVO I 2.0</b>	182 A1.000	Petrol	1998	5	<b>260</b>	<b>966</b>
07/98→10/01	<b>BRAVO I 2.0</b>	182 B7.000	Petrol	1998	5	<b>262</b>	<b>968</b>
04/07→	<b>BRAVO II 1.4</b>	192 B2.000	Petrol	1368	4	<b>66</b>	<b>813</b>





ccm

X



9



09/07→	<b>BRAVO II 1.4</b>	198 A1.000	Petrol	1368	4	<b>69</b>	<b>815</b>
09/07→	<b>BRAVO II 1.4</b>	198 A4.000	Petrol	1368	4	<b>69</b>	<b>815</b>
03/08→	<b>BRAVO II 1.4</b>	198 A7.000	Petrol	1368	4	<b>68</b>	<b>815</b>
03/08→	<b>BRAVO II 1.6</b>	198 A2.000	Diesel	1598	4	<b>116</b>	<b>864</b>
03/08→	<b>BRAVO II 1.6</b>	198 A3.000	Diesel	1598	4	<b>116</b>	<b>865</b>
03/08→	<b>BRAVO II 1.6</b>	198 A6.000	Diesel	1598	4	<b>117</b>	<b>866</b>
11/08→	<b>BRAVO II 1.6</b>	955 A4.000	Diesel	1598	4	<b>117</b>	<b>869</b>
11/06→	<b>BRAVO II 1.9</b>	192 A1.000	Diesel	1910	4	<b>221</b>	<b>945</b>
11/06→	<b>BRAVO II 1.9</b>	192 B4.000	Diesel	1910	4	<b>227</b>	<b>949</b>
04/07→12/08	<b>BRAVO II 1.9</b>	192 B5.000	Diesel	1910	4	<b>228</b>	<b>948</b>
04/07→	<b>BRAVO II 1.9</b>	192 A8.000	Diesel	1910	4	<b>225</b>	<b>947</b>
04/07→	<b>BRAVO II 1.9</b>	937 A5.000	Diesel	1910	4	<b>240</b>	<b>946</b>
09/08→	<b>BRAVO II 2.0</b>	198 A5.000	Diesel	1956	4	<b>341</b>	<b>1030</b>
09/08→	<b>BRAVO II 2.0</b>	844 A2.000	Diesel	1956	4	<b>342</b>	<b>1034</b>
03/08→	<b>BRAVO VAN 1.6</b>	198 A3.000	Diesel	1598	4	<b>116</b>	<b>865</b>
06/74→10/89	<b>CAMPAGNOLA 2.0</b>	6132 AZ 2.000	Petrol	1995	4	<b>479</b>	<b>1148</b>
06/74→10/89	<b>CAMPAGNOLA 2.4</b>	8144.61.200	Diesel	2445	4	<b>628</b>	<b>1268</b>
12/91→01/96	<b>CINQUECENTO 0.7</b>	170 A.000	Petrol	704	2	<b>165</b>	<b>905</b>
07/94→01/98	<b>CINQUECENTO 0.7</b>	170 A.046	Petrol	704	2	<b>165</b>	<b>906</b>
07/91→12/93	<b>CINQUECENTO 0.9</b>	170 A1.000	Petrol	903	4	<b>14</b>	<b>763</b>
07/91→12/93	<b>CINQUECENTO 0.9</b>	170 A1.046	Petrol	903	4	<b>15</b>	<b>763</b>
07/91→07/99	<b>CINQUECENTO 0.9</b>	1170 A1.000	Petrol	899	4	<b>5</b>	<b>755</b>
07/91→07/99	<b>CINQUECENTO 0.9</b>	1170 A1.046	Petrol	899	4	<b>6</b>	<b>756</b>
10/94→01/98	<b>CINQUECENTO 1.1</b>	176 B2.000	Petrol	1108	4	<b>38</b>	<b>787</b>
03/96→08/00	<b>COUPE 1.8</b>	183 A1.000	Petrol	1747	4	<b>197</b>	<b>929</b>
11/93→08/96	<b>COUPE 2.0</b>	175 A1.000	Petrol	1995	4	<b>443</b>	<b>1125</b>
11/93→08/96	<b>COUPE 2.0</b>	836 A3.000	Petrol	1995	4	<b>476</b>	<b>1121</b>
08/96→04/98	<b>COUPE 2.0</b>	182 A1.000	Petrol	1998	5	<b>260</b>	<b>966</b>
08/96→08/00	<b>COUPE 2.0</b>	175 A3.000	Petrol	1998	5	<b>259</b>	<b>965</b>
04/98→08/00	<b>COUPE 2.0</b>	182 B3.000	Petrol	1998	5	<b>261</b>	<b>967</b>
12/85→12/90	<b>CROMA 1.6</b>	154 A.048	Petrol	1585	4	<b>384</b>	<b>1067</b>
12/05→	<b>CROMA 1.8</b>	939 A4.000	Petrol	1796	4	<b>182</b>	<b>917</b>
05/89→10/92	<b>CROMA 1.9</b>	154 C6.000	Diesel	1929	4	<b>310</b>	<b>1004</b>
11/92→12/96	<b>CROMA 1.9</b>	154 D1.000	Diesel	1929	4	<b>310</b>	<b>1005</b>
06/05→	<b>CROMA 1.9</b>	939 A1.000	Diesel	1910	4	<b>247</b>	<b>945</b>
06/05→	<b>CROMA 1.9</b>	939 A2.000	Diesel	1910	4	<b>249</b>	<b>961</b>
06/05→	<b>CROMA 1.9</b>	939 A7.000	Diesel	1910	4	<b>227</b>	<b>960</b>
12/05→	<b>CROMA 1.9</b>	939 A8.000	Diesel	1910	4	<b>252</b>	<b>962</b>
12/85→02/89	<b>CROMA 2.0</b>	154 A1.000	Petrol	1995	4	<b>434</b>	<b>1114</b>
12/85→06/90	<b>CROMA 2.0</b>	154 A2.000	Petrol	1995	4	<b>435</b>	<b>1115</b>
03/86→09/90	<b>CROMA 2.0</b>	834 B.048	Petrol	1995	4	<b>455</b>	<b>1136</b>
11/86→08/96	<b>CROMA 2.0</b>	834 C.146	Petrol	1995	4	<b>464</b>	<b>1141</b>
03/87→09/92	<b>CROMA 2.0</b>	154 C3.000	Petrol	1995	4	<b>436</b>	<b>1116</b>
03/87→09/92	<b>CROMA 2.0</b>	834 B.000	Petrol	1995	4	<b>453</b>	<b>1133</b>
06/87→08/96	<b>CROMA 2.0</b>	154 C4.046	Petrol	1995	4	<b>438</b>	<b>1119</b>
10/87→08/96	<b>CROMA 2.0</b>	154 C3.046	Petrol	1995	4	<b>437</b>	<b>1117</b>
10/87→08/96	<b>CROMA 2.0</b>	834 B.146	Petrol	1995	4	<b>457</b>	<b>1137</b>
08/92→08/96	<b>CROMA 2.0</b>	154 E1.000	Petrol	1995	4	<b>439</b>	<b>1121</b>
06/05→	<b>CROMA 2.2</b>	194 A1.000	Petrol	2198	4	<b>517</b>	<b>1174</b>
12/85→08/89	<b>CROMA 2.4</b>	8144.91.2000	Diesel	2445	4	<b>634</b>	<b>1272</b>
06/05→	<b>CROMA 2.4</b>	939 A3.000	Diesel	2387	5	<b>286</b>	<b>987</b>
12/85→12/89	<b>CROMA 2.5</b>	8144.67	Diesel	2500	4	<b>679</b>	<b>1318</b>
05/89→08/96	<b>CROMA 2.5</b>	8144.97	Diesel	2499	4	<b>668</b>	<b>1307</b>
05/89→08/96	<b>CROMA 2.5</b>	8144.97 Y	Diesel	2500	4	<b>682</b>	<b>1320</b>
05/89→08/96	<b>CROMA 2.5</b>	8144.97.2400	Diesel	2499	4	<b>670</b>	<b>1307</b>
12/91→08/96	<b>CROMA 2.5</b>	8144.97 S	Diesel	2500	4	<b>680</b>	<b>1307</b>
06/93→08/96	<b>CROMA 2.5</b>	834 G.000	Petrol	2492	V6	<b>592</b>	<b>1237</b>
03/01→	<b>DOBLO 1.2</b>	223 A5.000	Petrol	1242	4	<b>63</b>	<b>805</b>
12/04→05/05	<b>DOBLO 1.3</b>	188 A9.000	Diesel	1248	4	<b>22</b>	<b>776</b>
05/05→	<b>DOBLO 1.3</b>	199 A2.000	Diesel	1248	4	<b>22</b>	<b>777</b>
10/05→	<b>DOBLO 1.3</b>	223 A9.000	Diesel	1248	4	<b>33</b>	<b>783</b>
10/05→	<b>DOBLO 1.4</b>	350 A1.000	Petrol	1368	4	<b>76</b>	<b>825</b>
10/01→	<b>DOBLO 1.6</b>	182 B6.000	Petrol	1596	4	<b>181</b>	<b>916</b>
03/01→	<b>DOBLO 1.9</b>	223 A6.000	Diesel	1910	4	<b>230</b>	<b>951</b>
10/01→	<b>DOBLO 1.9</b>	182 B9.000	Diesel	1910	4	<b>211</b>	<b>939</b>
10/01→	<b>DOBLO 1.9</b>	223 B2.000	Diesel	1910	4	<b>233</b>	<b>938</b>
07/03→	<b>DOBLO 1.9</b>	223 A7.000	Diesel	1910	4	<b>231</b>	<b>942</b>
07/03→	<b>DOBLO 1.9</b>	223 B1.000	Diesel	1910	4	<b>232</b>	<b>938</b>
10/05→	<b>DOBLO 1.9</b>	186 A9.000	Diesel	1910	4	<b>215</b>	<b>942</b>
02/10→	<b>DOBLO BOX BODY / ESTATE 1.3</b>	199 A3.000	Diesel	1248	4	<b>28</b>	<b>778</b>
02/10→	<b>DOBLO BOX BODY / ESTATE 1.3</b>	263 A2.000	Diesel	1248	4	<b>32</b>	<b>784</b>
02/10→	<b>DOBLO BOX BODY / ESTATE 1.4</b>	843 A1.000	Petrol	1368	4	<b>77</b>	<b>818</b>



ccm

x



9



06/10→	<b>DOBLO BOX BODY / ESTATE 1.4</b>	198 A4.000	Petrol	1368	4	<b>69</b>	<b>815</b>
02/10→	<b>DOBLO BOX BODY / ESTATE 1.6</b>	198 A3.000	Diesel	1598	4	<b>116</b>	<b>865</b>
02/10→	<b>DOBLO BOX BODY / ESTATE 1.6</b>	263 A3.000	Diesel	1598	4	<b>116</b>	<b>866</b>
02/10→	<b>DOBLO BOX BODY / ESTATE 1.6</b>	263 A4.000	Diesel	1598	4	<b>117</b>	<b>866</b>
02/10→	<b>DOBLO BOX BODY / ESTATE 2.0</b>	263 A1.000	Diesel	1956	4	<b>341</b>	<b>1032</b>
03/01→	<b>DOBLO CARGO 1.2</b>	223 A5.000	Petrol	1242	4	<b>63</b>	<b>805</b>
05/04→12/06	<b>DOBLO CARGO 1.3</b>	188 A8.000	Diesel	1248	4	<b>25</b>	<b>776</b>
05/04→12/06	<b>DOBLO CARGO 1.3</b>	188 A9.000	Diesel	1248	4	<b>22</b>	<b>776</b>
10/05→01/10	<b>DOBLO CARGO 1.3</b>	199 A2.000	Diesel	1248	4	<b>22</b>	<b>777</b>
08/06→	<b>DOBLO CARGO 1.3</b>	223 A9.000	Diesel	1248	4	<b>33</b>	<b>783</b>
10/05→	<b>DOBLO CARGO 1.4</b>	350 A1.000	Petrol	1368	4	<b>76</b>	<b>825</b>
10/01→	<b>DOBLO CARGO 1.6</b>	182 B6.000	Petrol	1596	4	<b>181</b>	<b>916</b>
03/01→	<b>DOBLO CARGO 1.9</b>	223 A6.000	Diesel	1910	4	<b>230</b>	<b>951</b>
10/01→	<b>DOBLO CARGO 1.9</b>	182 B9.000	Diesel	1910	4	<b>211</b>	<b>939</b>
07/03→	<b>DOBLO CARGO 1.9</b>	223 A7.000	Diesel	1910	4	<b>231</b>	<b>942</b>
07/03→	<b>DOBLO CARGO 1.9</b>	223 B1.000	Diesel	1910	4	<b>232</b>	<b>938</b>
12/06→	<b>DOBLO CARGO 1.9</b>	186 A9.000	Diesel	1910	4	<b>215</b>	<b>942</b>
02/10→	<b>DOBLO MPV 1.3</b>	199 A3.000	Diesel	1248	4	<b>28</b>	<b>778</b>
02/10→	<b>DOBLO MPV 1.3</b>	263 A2.000	Diesel	1248	4	<b>32</b>	<b>784</b>
02/10→	<b>DOBLO MPV 1.4</b>	198 A4.000	Petrol	1368	4	<b>69</b>	<b>815</b>
02/10→	<b>DOBLO MPV 1.4</b>	843 A1.000	Petrol	1368	4	<b>77</b>	<b>818</b>
02/10→	<b>DOBLO MPV 1.6</b>	198 A3.000	Diesel	1598	4	<b>116</b>	<b>865</b>
02/10→	<b>DOBLO MPV 1.6</b>	263 A4.000	Diesel	1598	4	<b>117</b>	<b>866</b>
02/10→	<b>DOBLO MPV 2.0</b>	263 A1.000	Diesel	1956	4	<b>341</b>	<b>1032</b>
02/10→	<b>DOBLO PLATFORM/CHASSIS 1.3</b>	199 A3.000	Diesel	1248	4	<b>28</b>	<b>778</b>
02/10→	<b>DOBLO PLATFORM/CHASSIS 1.3</b>	263 A2.000	Diesel	1248	4	<b>32</b>	<b>784</b>
04/10→	<b>DOBLO PLATFORM/CHASSIS 1.4</b>	843 A1.000	Petrol	1368	4	<b>77</b>	<b>818</b>
02/10→	<b>DOBLO PLATFORM/CHASSIS 1.6</b>	198 A3.000	Diesel	1598	4	<b>116</b>	<b>865</b>
02/10→	<b>DOBLO PLATFORM/CHASSIS 1.6</b>	263 A4.000	Diesel	1598	4	<b>117</b>	<b>866</b>
02/11→	<b>DOBLO PLATFORM/CHASSIS 1.6</b>	263 A3.000	Diesel	1598	4	<b>116</b>	<b>866</b>
02/10→	<b>DOBLO PLATFORM/CHASSIS 2.0</b>	263 A1.000	Diesel	1956	4	<b>341</b>	<b>1032</b>
01/82→10/88	<b>DUCATO BOX 1.8</b>	169 B	Petrol	1796	4	<b>413</b>	<b>1094</b>
01/88→03/94	<b>DUCATO BOX 1.9</b>	149 B1.000	Diesel	1929	4	<b>307</b>	<b>1001</b>
03/89→03/94	<b>DUCATO BOX 1.9</b>	280 A1.000	Diesel	1929	4	<b>320</b>	<b>1010</b>
03/94→04/02	<b>DUCATO BOX 1.9</b>	230 A2.000	Diesel	1929	4	<b>318</b>	<b>1009</b>
03/94→04/02	<b>DUCATO BOX 1.9</b>	230 A3.000	Diesel	1929	4	<b>319</b>	<b>1010</b>
08/94→04/02	<b>DUCATO BOX 1.9</b>	230 A4.000	Diesel	1929	4	<b>319</b>	<b>1010</b>
04/98→04/02	<b>DUCATO BOX 1.9</b>	DHX (XUD9TF/L)	Diesel	1905	4	<b>336</b>	<b>1026</b>
04/98→04/02	<b>DUCATO BOX 1.9</b>	DJY	Diesel	1905	4	<b>339</b>	<b>1029</b>
01/82→08/90	<b>DUCATO BOX 2.0</b>	XN 1T	Petrol	1971	4	<b>576</b>	<b>1225</b>
07/85→08/90	<b>DUCATO BOX 2.0</b>	170 B	Petrol	1971	4	<b>574</b>	<b>1224</b>
03/89→05/94	<b>DUCATO BOX 2.0</b>	170 D	Petrol	1971	4	<b>575</b>	<b>1224</b>
03/94→04/02	<b>DUCATO BOX 2.0</b>	RFW	Petrol	1998	4	<b>513</b>	<b>1176</b>
10/01→	<b>DUCATO BOX 2.0</b>	RHV (DW10)	Diesel	1997	4	<b>494</b>	<b>1163</b>
04/02→	<b>DUCATO BOX 2.0</b>	RFL	Petrol	1998	4	<b>509</b>	<b>1175</b>
06/11→	<b>DUCATO BOX 2.0</b>	250 A1.000	Diesel	1956	4	<b>340</b>	<b>1032</b>
07/06→	<b>DUCATO BOX 2.2</b>	4HV	Diesel	2198	4	<b>516</b>	<b>1182</b>
04/02→	<b>DUCATO BOX 2.3</b>	F1AE0481C	Diesel	2286	4	<b>580</b>	<b>1229</b>
07/06→	<b>DUCATO BOX 2.3</b>	F1AE0481D	Diesel	2287	4	<b>585</b>	<b>1232</b>
08/06→	<b>DUCATO BOX 2.3</b>	F1AE0481T	Diesel	2286	4	<b>581</b>	<b>1230</b>
01/07→	<b>DUCATO BOX 2.3</b>	F1AE0481N	Diesel	2287	4	<b>589</b>	<b>1233</b>
01/07→	<b>DUCATO BOX 2.3</b>	F1AE3481D	Diesel	2287	4	<b>591</b>	<b>1235</b>
06/11→	<b>DUCATO BOX 2.3</b>	F1AE3481E	Diesel	2287	4	<b>589</b>	<b>1235</b>
10/11→	<b>DUCATO BOX 2.3</b>	F1AE3481G	Diesel	2287	4	<b>589</b>	<b>1236</b>
01/82→08/90	<b>DUCATO BOX 2.4</b>	8144.61	Diesel	2428	4	<b>612</b>	<b>1250</b>
01/82→05/94	<b>DUCATO BOX 2.5</b>	8144.67	Diesel	2500	4	<b>679</b>	<b>1318</b>
01/82→08/90	<b>DUCATO BOX 2.5</b>	CRD93L (U25-661)	Diesel	2500	4	<b>684</b>	<b>1321</b>
09/86→03/94	<b>DUCATO BOX 2.5</b>	8140.27	Diesel	2500	4	<b>672</b>	<b>1311</b>
09/86→05/90	<b>DUCATO BOX 2.5</b>	8140.61	Diesel	2445	4	<b>618</b>	<b>1260</b>
03/94→04/02	<b>DUCATO BOX 2.5</b>	8140.47	Diesel	2500	4	<b>674</b>	<b>1313</b>
03/94→04/02	<b>DUCATO BOX 2.5</b>	8140.47R	Diesel	2500	4	<b>675</b>	<b>1313</b>
03/94→04/02	<b>DUCATO BOX 2.5</b>	8140.67	Diesel	2500	4	<b>676</b>	<b>1314</b>
10/97→04/02	<b>DUCATO BOX 2.8</b>	8140.43	Diesel	2800	4	<b>736</b>	<b>1344</b>
05/98→04/02	<b>DUCATO BOX 2.8</b>	8140.63	Diesel	2800	4	<b>737</b>	<b>1345</b>
11/00→	<b>DUCATO BOX 2.8</b>	8140.43S	Diesel	2798	4	<b>731</b>	<b>1342</b>
05/04→	<b>DUCATO BOX 2.8</b>	8140.43N	Diesel	2798	4	<b>726</b>	<b>1340</b>
07/06→	<b>DUCATO BOX 3.0</b>	F1CE0481D	Diesel	2999	4	<b>746</b>	<b>1353</b>
07/06→	<b>DUCATO BOX 3.0</b>	F1CE3481M	Diesel	2999	4	<b>747</b>	<b>1353</b>
04/09→	<b>DUCATO BOX 3.0</b>	F1CE0441A	Petrol	2999	4	<b>745</b>	<b>1353</b>
04/10→	<b>DUCATO BOX 3.0</b>	F1CE3481N	Diesel	2999	4	<b>747</b>	<b>1353</b>
06/11→	<b>DUCATO BOX 3.0</b>	F1CE3481E	Diesel	2999	4	<b>747</b>	<b>1353</b>
03/94→04/02	<b>DUCATO BUS 1.9</b>	230 A3.000	Diesel	1929	4	<b>319</b>	<b>1010</b>



ccm

X



9



08/94→04/02	DUCATO BUS 1.9	230 A4.000	Diesel	1929	4	319	1010
06/95→04/02	DUCATO BUS 1.9	230 A2.000	Diesel	1929	4	318	1009
04/98→04/02	DUCATO BUS 1.9	D9B	Diesel	1905	4	333	1024
04/98→04/02	DUCATO BUS 1.9	D9B (XUD9A)	Diesel	1905	4	334	1025
04/98→04/02	DUCATO BUS 1.9	DHX (XUD9TF/L)	Diesel	1905	4	336	1026
04/98→04/02	DUCATO BUS 1.9	DJY	Diesel	1905	4	339	1029
03/94→04/02	DUCATO BUS 2.0	RFW	Petrol	1998	4	513	1176
10/01→	DUCATO BUS 2.0	RHV (DW10)	Diesel	1997	4	494	1163
04/02→	DUCATO BUS 2.0	RFL	Petrol	1998	4	509	1175
06/11→	DUCATO BUS 2.0	250 A1.000	Diesel	1956	4	340	1032
07/06→	DUCATO BUS 2.2	4HV	Diesel	2198	4	516	1182
04/02→	DUCATO BUS 2.3	F1AE0481C	Diesel	2286	4	580	1229
07/06→	DUCATO BUS 2.3	F1AE0481D	Diesel	2287	4	585	1232
01/07→	DUCATO BUS 2.3	F1AE3481D	Diesel	2287	4	591	1235
06/11→	DUCATO BUS 2.3	F1AE3481E	Diesel	2287	4	589	1235
10/11→	DUCATO BUS 2.3	F1AE3481G	Diesel	2287	4	589	1236
03/94→04/02	DUCATO BUS 2.5	8140.47	Diesel	2500	4	674	1313
07/94→04/02	DUCATO BUS 2.5	8140.47R	Diesel	2500	4	675	1313
08/94→04/02	DUCATO BUS 2.5	8140.67	Diesel	2500	4	676	1314
10/97→04/02	DUCATO BUS 2.8	8140.43	Diesel	2800	4	736	1344
02/98→04/02	DUCATO BUS 2.8	8140.63	Diesel	2800	4	737	1345
11/00→	DUCATO BUS 2.8	8140.43S	Diesel	2798	4	731	1342
04/04→07/06	DUCATO BUS 2.8	8140.43N	Diesel	2798	4	726	1340
07/06→	DUCATO BUS 3.0	F1CE0481D	Diesel	2999	4	746	1353
07/06→	DUCATO BUS 3.0	F1CE3481M	Diesel	2999	4	747	
04/09→	DUCATO BUS 3.0	F1CE0441A	Petrol	2999	4	745	
04/10→	DUCATO BUS 3.0	F1CE3481N	Diesel	2999	4	747	
06/11→	DUCATO BUS 3.0	F1CE3481E	Diesel	2999	4	747	
07/82→12/88	DUCATO PANORAMA 1.8	XM7T	Petrol	1796	4		1095
02/87→03/94	DUCATO PANORAMA 1.9	149 B1.000	Diesel	1929	4	307	1001
03/89→03/94	DUCATO PANORAMA 1.9	280 A1.000	Diesel	1929	4	320	1010
07/82→05/85	DUCATO PANORAMA 2.0	XN 1T	Petrol	1971	4	576	1225
01/86→08/90	DUCATO PANORAMA 2.0	170 B	Petrol	1971	4	574	1224
09/88→05/94	DUCATO PANORAMA 2.0	170 D	Petrol	1971	4	575	1224
07/82→12/85	DUCATO PANORAMA 2.4	8144.61	Diesel	2428	4	612	1250
01/86→08/90	DUCATO PANORAMA 2.5	8144.21	Diesel	2445	4	624	1265
01/86→03/94	DUCATO PANORAMA 2.5	8144.67	Diesel	2500	4	679	1318
01/86→08/90	DUCATO PANORAMA 2.5	CRD93L (U25-661)	Diesel	2500	4	684	1321
01/87→08/90	DUCATO PANORAMA 2.5	8144.21.220	Diesel	2445	4	626	1266
08/90→03/94	DUCATO PANORAMA 2.5	8140.27	Diesel	2500	4	672	1311
01/88→08/90	DUCATO PLATFORM/CHASSIS 1.9	149 B1.000	Diesel	1929	4	307	1001
03/89→03/94	DUCATO PLATFORM/CHASSIS 1.9	280 A1.000	Diesel	1929	4	320	1010
03/94→04/02	DUCATO PLATFORM/CHASSIS 1.9	230 A2.000	Diesel	1929	4	318	1009
03/94→04/02	DUCATO PLATFORM/CHASSIS 1.9	230 A3.000	Diesel	1929	4	319	1010
08/94→04/02	DUCATO PLATFORM/CHASSIS 1.9	230 A4.000	Diesel	1929	4	319	1010
04/98→04/02	DUCATO PLATFORM/CHASSIS 1.9	DHX (XUD9TF/L)	Diesel	1905	4	336	1026
04/98→04/02	DUCATO PLATFORM/CHASSIS 1.9	DJY	Diesel	1905	4	339	1029
07/85→08/90	DUCATO PLATFORM/CHASSIS 2.0	170 B	Petrol	1971	4	574	1224
08/88→05/94	DUCATO PLATFORM/CHASSIS 2.0	170 D	Petrol	1971	4	575	1224
06/98→04/02	DUCATO PLATFORM/CHASSIS 2.0	RFW	Petrol	1998	4	513	1176
07/01→07/06	DUCATO PLATFORM/CHASSIS 2.0	RHV (DW10)	Diesel	1997	4	494	1163
04/02→07/06	DUCATO PLATFORM/CHASSIS 2.0	RFL	Petrol	1998	4	509	1175
06/11→	DUCATO PLATFORM/CHASSIS 2.0	250 A1.000	Diesel	1956	4	340	1032
07/06→	DUCATO PLATFORM/CHASSIS 2.2	4HV	Diesel	2198	4	516	1182
04/02→07/06	DUCATO PLATFORM/CHASSIS 2.3	F1AE0481C	Diesel	2286	4	580	1229
07/06→	DUCATO PLATFORM/CHASSIS 2.3	F1AE0481D	Diesel	2287	4	585	1232
01/07→	DUCATO PLATFORM/CHASSIS 2.3	F1AE0481N	Diesel	2287	4	589	1233
01/07→	DUCATO PLATFORM/CHASSIS 2.3	F1AE3481D	Diesel	2287	4	591	1235
06/11→	DUCATO PLATFORM/CHASSIS 2.3	F1AE3481E	Diesel	2287	4	589	1235
10/11→	DUCATO PLATFORM/CHASSIS 2.3	F1AE3481G	Diesel	2287	4	589	1236
07/82→03/94	DUCATO PLATFORM/CHASSIS 2.5	8144.67	Diesel	2500	4	679	1318
07/82→08/90	DUCATO PLATFORM/CHASSIS 2.5	CRD93L (U25-661)	Diesel	2500	4	684	1321
01/86→08/90	DUCATO PLATFORM/CHASSIS 2.5	8144.21	Diesel	2445	4	624	1265
07/90→03/94	DUCATO PLATFORM/CHASSIS 2.5	8140.27	Diesel	2500	4	672	1311
03/94→04/02	DUCATO PLATFORM/CHASSIS 2.5	8140.47	Diesel	2500	4	674	1313
03/94→04/02	DUCATO PLATFORM/CHASSIS 2.5	8140.47R	Diesel	2500	4	675	1313
03/94→04/02	DUCATO PLATFORM/CHASSIS 2.5	8140.67	Diesel	2500	4	676	1314
02/98→04/02	DUCATO PLATFORM/CHASSIS 2.8	8140.63	Diesel	2800	4	737	1345
05/98→04/02	DUCATO PLATFORM/CHASSIS 2.8	8140.43	Diesel	2800	4	736	1344
11/00→07/06	DUCATO PLATFORM/CHASSIS 2.8	8140.43S	Diesel	2798	4	731	1342
05/04→07/06	DUCATO PLATFORM/CHASSIS 2.8	8140.43N	Diesel	2798	4	726	1340
07/06→	DUCATO PLATFORM/CHASSIS 3.0	F1CE0481D	Diesel	2999	4	746	1353



ccm

x



9



07/06→	DUCATO PLATFORM/CHASSIS 3.0	F1CE3481M	Diesel	2999	4	747	
04/09→	DUCATO PLATFORM/CHASSIS 3.0	F1CE0441A	Petrol	2999	4	745	
04/10→	DUCATO PLATFORM/CHASSIS 3.0	F1CE3481N	Diesel	2999	4	747	
06/11→	DUCATO PLATFORM/CHASSIS 3.0	F1CE3481E	Diesel	2999	4	747	
01/87→12/91	DUNA 1.1	146 A6.000	Petrol	1116	4	126	874
01/87→12/91	DUNA 1.3	146 A5.000	Petrol	1301	4	521	1185
01/87→12/91	DUNA 1.7	149 B3.000	Diesel	1698	4	301	994
07/91→07/96	DUNA SALOON 1.1	146 A4.048	Petrol	1116	4	125	873
01/87→12/91	DUNA WEEKEND 1.1	146 A6.000	Petrol	1116	4	126	874
01/87→12/91	DUNA WEEKEND 1.3	146 A5.000	Petrol	1301	4	521	1185
01/87→12/91	DUNA WEEKEND 1.7	149 B3.000	Diesel	1698	4	301	994
04/86→10/92	ELBA 1.3	127 A5.000	Diesel	1302	4	95	846
04/86→12/96	ELBA 1.5	149 C1.000	Petrol	1499	4	539	1197
04/89→12/96	ELBA 1.7	146 B2.000	Diesel	1698	4	299	994
10/77→12/84	FIORINO 0.9	100 GL.000	Petrol	903	4	8	758
01/80→12/87	FIORINO 1.0	127 A.000	Petrol	1049	4	88	839
12/86→04/88	FIORINO 1.0	156 A.000	Petrol	1049	4	98	848
11/86→04/88	FIORINO 1.1	146 A9.000	Petrol	1116	4	127	875
03/82→12/87	FIORINO 1.3	127 A5.000	Diesel	1302	4	95	846
12/87→08/93	FIORINO 1.3	146 A5.000	Petrol	1301	4	521	1185
01/88→08/93	FIORINO 1.5	149 C1.000	Petrol	1499	4	539	1197
12/87→12/90	FIORINO 1.7	149 B3.000	Diesel	1698	4	301	994
01/88→10/93	FIORINO 1.7	149 B2.000	Diesel	1697	4	295	995
05/88→12/93	FIORINO BOX 1.1	146 A9.000	Petrol	1116	4	127	875
01/88→12/94	FIORINO BOX 1.3	146 A5.000	Petrol	1301	4	521	1185
11/92→05/01	FIORINO BOX 1.4	146 C5.000	Petrol	1372	4	171	910
05/94→05/01	FIORINO BOX 1.4	146 D5.000	Petrol	1372	4	171	910
05/88→12/93	FIORINO BOX 1.5	149 C1.000	Petrol	1499	4	539	1197
10/93→05/01	FIORINO BOX 1.6	146 C6.000	Petrol	1581	4	540	1198
10/93→05/01	FIORINO BOX 1.6	146 D6.000	Petrol	1581	4	540	1198
01/88→10/99	FIORINO BOX 1.7	146 B2.000	Diesel	1698	4	299	994
05/88→05/00	FIORINO BOX 1.7	149 B3.000	Diesel	1698	4	301	994
11/96→05/01	FIORINO BOX 1.7	146 D7.000	Diesel	1698	4	300	996
11/07→	FIORINO BOX BODY / ESTATE 1.3	199 A9.000	Diesel	1248	4	30	780
07/09→	FIORINO BOX BODY / ESTATE 1.3	199 B1.000	Diesel	1248	4	30	780
11/07→	FIORINO BOX BODY / ESTATE 1.4	KFT	Petrol	1360	4	85	837
11/07→	FIORINO BOX BODY / ESTATE 1.4	KFV	Petrol	1360	4	85	837
10/09→	FIORINO BOX BODY / ESTATE 1.4	350 A1.000	Petrol	1368	4	76	825
09/87→12/88	FIORINO PICK UP 1.0	156 A.000	Petrol	1049	4	98	848
05/84→12/88	FIORINO PICK UP 1.3	127 A5.000	Diesel	1302	4	95	846
01/88→12/94	FIORINO PICK UP 1.3	146 A5.000	Petrol	1301	4	521	1185
05/94→05/01	FIORINO PICK UP 1.4	146 D5.000	Petrol	1372	4	171	910
01/88→10/92	FIORINO PICK UP 1.5	149 C1.000	Petrol	1499	4	539	1197
01/94→05/01	FIORINO PICK UP 1.6	146 C6.000	Petrol	1581	4	540	1198
01/94→05/01	FIORINO PICK UP 1.6	146 D6.000	Petrol	1581	4	540	1198
05/88→10/99	FIORINO PICK UP 1.7	149 B3.000	Diesel	1698	4	301	994
10/93→10/99	FIORINO PICK UP 1.7	146 B2.000	Diesel	1698	4	299	994
01/97→05/01	FIORINO PICK UP 1.7	146 D7.000	Diesel	1698	4	300	996
08/11→	FREEMONT 2.0	939 B5.000	Diesel	1956	4	340	1035
08/11→	FREEMONT 2.0	940 A5.000	Diesel	1956	4	340	1035
05/73→12/79	X 1/9 1.3	128 AS.000	Petrol	1290	4	507	1173
11/78→12/89	X 1/9 1.5	138 AS.000	Petrol	1499	4	537	1192
06/85→12/89	X 1/9 1.5	138 BS.031	Petrol	1499	4		1190
01/04→	IDEA 1.2	188 A5.000	Petrol	1242	4	60	810
01/04→	IDEA 1.3	188 A9.000	Diesel	1248	4	22	776
10/05→	IDEA 1.3	199 A3.000	Diesel	1248	4	28	778
05/08→	IDEA 1.3	199 B1.000	Diesel	1248	4	30	780
12/03→	IDEA 1.4	192 B2.000	Petrol	1368	4	66	813
01/04→	IDEA 1.4	843 A1.000	Petrol	1368	4	77	818
10/05→	IDEA 1.4	350 A1.000	Petrol	1368	4	76	825
05/08→	IDEA 1.6	350 A2.000	Diesel	1598	4	117	867
01/04→	IDEA 1.9	188 B2.000	Diesel	1910	4	220	942
06/07→	LINEA 1.3	199 A3.000	Diesel	1248	4	28	778
06/07→	LINEA 1.4	350 A1.000	Petrol	1368	4	76	825
09/07→	LINEA 1.4	198 A4.000	Petrol	1368	4	69	815
06/09→	LINEA 1.6	198 A3.000	Diesel	1598	4	116	865
10/98→05/02	MAREA 1.2	182 B2.000	Petrol	1242	4	57	807
09/96→05/02	MAREA 1.4	182 A3.000	Petrol	1370	4	184	923
09/96→05/02	MAREA 1.6	182 A4.000	Petrol	1581	4	551	1208
04/97→05/02	MAREA 1.6	185 A4.000	Petrol	1581	4	555	1208
04/99→05/02	MAREA 1.6	186 A4.000	Petrol	1581	4	557	1212
09/00→08/02	MAREA 1.6	182 B5.098	Petrol	1581	4	554	1206



ccm

X



9



09/00→08/02	<b>MAREA 1.6</b>	182 B6.000	Petrol	1596	4	<b>181</b>	<b>916</b>
09/96→05/02	<b>MAREA 1.8</b>	182 A2.000	Petrol	1747	4	<b>194</b>	<b>929</b>
09/96→05/02	<b>MAREA 1.9</b>	182 A7.000	Diesel	1910	4	<b>208</b>	<b>936</b>
09/96→05/02	<b>MAREA 1.9</b>	182 A8.000	Diesel	1910	4	<b>209</b>	<b>936</b>
04/99→01/01	<b>MAREA 1.9</b>	182 B4.000	Diesel	1910	4	<b>210</b>	<b>937</b>
01/01→05/02	<b>MAREA 1.9</b>	186 A6.000	Diesel	1910	4	<b>213</b>	<b>941</b>
09/96→04/99	<b>MAREA 2.0</b>	182 A1.000	Petrol	1998	5	<b>260</b>	<b>966</b>
04/99→01/01	<b>MAREA 2.0</b>	182 B7.000	Petrol	1998	5	<b>262</b>	<b>968</b>
01/01→05/02	<b>MAREA 2.0</b>	185 A8.000	Petrol	1998	5	<b>265</b>	<b>970</b>
09/96→04/99	<b>MAREA 2.4</b>	185 A2.000	Diesel	2387	5	<b>269</b>	<b>972</b>
04/99→05/02	<b>MAREA 2.4</b>	185 A6.000	Diesel	2387	5	<b>270</b>	<b>973</b>
04/99→05/02	<b>MAREA 2.4</b>	839 A5.000	Diesel	2387	5	<b>273</b>	<b>973</b>
10/98→05/02	<b>MAREA WEEKEND 1.2</b>	182 B2.000	Petrol	1242	4	<b>57</b>	<b>807</b>
09/96→05/02	<b>MAREA WEEKEND 1.4</b>	182 A3.000	Petrol	1370	4	<b>184</b>	<b>923</b>
09/96→05/02	<b>MAREA WEEKEND 1.6</b>	182 A4.000	Petrol	1581	4	<b>551</b>	<b>1208</b>
09/00→08/02	<b>MAREA WEEKEND 1.6</b>	182 B6.000	Petrol	1596	4	<b>181</b>	<b>916</b>
09/96→05/02	<b>MAREA WEEKEND 1.8</b>	182 A2.000	Petrol	1747	4	<b>194</b>	<b>929</b>
09/96→05/02	<b>MAREA WEEKEND 1.9</b>	182 A7.000	Diesel	1910	4	<b>208</b>	<b>936</b>
09/96→05/02	<b>MAREA WEEKEND 1.9</b>	182 A8.000	Diesel	1910	4	<b>209</b>	<b>936</b>
09/96→05/02	<b>MAREA WEEKEND 1.9</b>	182 B9.000	Diesel	1910	4	<b>211</b>	<b>939</b>
04/99→05/02	<b>MAREA WEEKEND 1.9</b>	182 B4.000	Diesel	1910	4	<b>210</b>	<b>937</b>
01/01→05/02	<b>MAREA WEEKEND 1.9</b>	186 A6.000	Diesel	1910	4	<b>213</b>	<b>941</b>
09/96→04/99	<b>MAREA WEEKEND 2.0</b>	182 A1.000	Petrol	1998	5	<b>260</b>	<b>966</b>
04/99→02/03	<b>MAREA WEEKEND 2.0</b>	182 B7.000	Petrol	1998	5	<b>262</b>	<b>968</b>
01/01→05/02	<b>MAREA WEEKEND 2.0</b>	185 A8.000	Petrol	1998	5	<b>265</b>	<b>970</b>
09/96→04/99	<b>MAREA WEEKEND 2.4</b>	185 A2.000	Diesel	2387	5	<b>269</b>	<b>972</b>
04/99→05/02	<b>MAREA WEEKEND 2.4</b>	185 A6.000	Diesel	2387	5	<b>270</b>	<b>973</b>
04/99→05/02	<b>MAREA WEEKEND 2.4</b>	839 A5.000	Diesel	2387	5	<b>273</b>	<b>973</b>
04/99→06/10	<b>MULTIPLA 1.6</b>	182 A4.000	Petrol	1581	4	<b>551</b>	<b>1208</b>
04/99→06/10	<b>MULTIPLA 1.6</b>	186 A3.000	LPG	1581	4	<b>556</b>	<b>1211</b>
04/99→06/10	<b>MULTIPLA 1.6</b>	186 A4.000	Petrol	1581	4	<b>557</b>	<b>1212</b>
09/00→06/10	<b>MULTIPLA 1.6</b>	182 B6.000	Petrol	1596	4	<b>181</b>	<b>916</b>
04/99→06/10	<b>MULTIPLA 1.9</b>	182 B4.000	Diesel	1910	4	<b>210</b>	<b>937</b>
03/01→07/02	<b>MULTIPLA 1.9</b>	186 A6.000	Diesel	1910	4	<b>213</b>	<b>941</b>
04/02→06/10	<b>MULTIPLA 1.9</b>	186 A9.000	Diesel	1910	4	<b>215</b>	<b>942</b>
07/02→06/10	<b>MULTIPLA 1.9</b>	186 A8.000	Diesel	1910	4	<b>214</b>	<b>939</b>
07/97→08/02	<b>PALIO 1.2</b>	178 B7.045	Petrol	1242	4	<b>54</b>	<b>804</b>
07/97→08/02	<b>PALIO 1.2</b>	178 C4.066	Petrol	1242	4	<b>55</b>	<b>804</b>
07/97→08/02	<b>PALIO 1.2</b>	188 A4.000	Petrol	1242	4	<b>58</b>	<b>809</b>
06/98→	<b>PALIO 1.2</b>	176 A8.000	Petrol	1242	4	<b>48</b>	<b>799</b>
06/98→	<b>PALIO 1.2</b>	178 B5.000	Petrol	1242	4	<b>53</b>	<b>803</b>
06/98→	<b>PALIO 1.2</b>	178 E2.000	Petrol	1242	4	<b>56</b>	<b>805</b>
04/96→	<b>PALIO 1.4</b>	178 B2.000	Petrol	1372	4	<b>176</b>	<b>910</b>
04/96→	<b>PALIO 1.4</b>	178 B2.016	Petrol	1372	4	<b>177</b>	<b>910</b>
06/03→	<b>PALIO 1.4</b>	834 A1.000	Petrol	1368	4	<b>71</b>	<b>826</b>
06/04→	<b>PALIO 1.5</b>	178 E5.022	Petrol	1461	4	<b>87</b>	
04/96→	<b>PALIO 1.6</b>	178 B3.000	Petrol	1581	4	<b>548</b>	<b>1205</b>
04/96→02/01	<b>PALIO WEEKEND 1.2</b>	178 B5.000	Petrol	1242	4	<b>53</b>	<b>803</b>
07/97→	<b>PALIO WEEKEND 1.2</b>	188 A4.000	Petrol	1242	4	<b>58</b>	<b>809</b>
06/99→10/02	<b>PALIO WEEKEND 1.2</b>	178 E2.000	Petrol	1242	4	<b>56</b>	<b>805</b>
02/01→	<b>PALIO WEEKEND 1.2</b>	178 C4.066	Petrol	1242	4	<b>55</b>	<b>804</b>
09/01→	<b>PALIO WEEKEND 1.2</b>	188 A5.000	Petrol	1242	4	<b>60</b>	<b>810</b>
01/04→	<b>PALIO WEEKEND 1.2</b>	178 E9.011	Petrol	1242	4		<b>806</b>
07/97→08/01	<b>PALIO WEEKEND 1.4</b>	178 B2.000	Petrol	1372	4	<b>176</b>	<b>910</b>
02/05→	<b>PALIO WEEKEND 1.4</b>	310 A2.011	Petrol	1368	4		<b>820</b>
02/02→	<b>PALIO WEEKEND 1.5</b>	178 E5.022	Petrol	1461	4	<b>87</b>	
04/96→02/01	<b>PALIO WEEKEND 1.6</b>	178 B3.000	Petrol	1581	4	<b>548</b>	<b>1205</b>
07/97→10/03	<b>PALIO WEEKEND 1.6</b>	178 C7.098	Petrol	1581	4	<b>549</b>	<b>1206</b>
07/97→10/03	<b>PALIO WEEKEND 1.6</b>	178 D2.011	Petrol	1581	4	<b>550</b>	<b>1207</b>
02/01→	<b>PALIO WEEKEND 1.6</b>	182 B6.000	Petrol	1596	4	<b>181</b>	<b>916</b>
04/96→03/01	<b>PALIO WEEKEND 1.7</b>	176 A3.000	Diesel	1698	4	<b>302</b>	<b>997</b>
03/01→	<b>PALIO WEEKEND 1.9</b>	223 A6.000	Diesel	1910	4	<b>230</b>	<b>951</b>
09/01→	<b>PALIO WEEKEND 1.9</b>	188 A2.000	Diesel	1910	4	<b>216</b>	<b>941</b>
01/82→07/04	<b>PANDA 0.7</b>	141 A.000	Petrol	652	2	<b>103</b>	<b>851</b>
01/86→01/95	<b>PANDA 0.7</b>	156 A4.000	Petrol	770	4	<b>2</b>	<b>750</b>
02/81→12/85	<b>PANDA 0.8</b>	100 GL6.000	Petrol	843	4		<b>754</b>
01/86→01/95	<b>PANDA 0.8</b>	141 B.000	Petrol	769	4	<b>1</b>	<b>749</b>
01/95→10/03	<b>PANDA 0.8</b>	156 A4.048	Petrol	770	4	<b>3</b>	<b>750</b>
10/80→04/86	<b>PANDA 0.9</b>	146 A.048	Petrol	903	4	<b>12</b>	<b>751</b>
10/80→06/94	<b>PANDA 0.9</b>	100 GL3.000	Petrol	903	4	<b>10</b>	<b>760</b>
10/80→06/94	<b>PANDA 0.9</b>	146 A.000	Petrol	903	4	<b>11</b>	<b>761</b>
09/82→12/86	<b>PANDA 0.9</b>	A 112 B1.054	Petrol	965	4	<b>20</b>	<b>770</b>



ccm



9



04/92→12/96	<b>PANDA 0.9</b>	1170 A1.046	Petrol	899	4	6	756
02/12→	<b>PANDA 0.9</b>	312 A2.000	Petrol	875	2		922
01/85→12/92	<b>PANDA 1.0</b>	156 A3.000	Petrol	999	4	37	793
01/86→07/89	<b>PANDA 1.0</b>	156 A3.100	Petrol	999	4	36	790
01/86→04/92	<b>PANDA 1.0</b>	156 A2.100	Petrol	999	4	36	793
05/86→08/98	<b>PANDA 1.0</b>	141 C2.000	Petrol	999	4	41	790
05/86→08/98	<b>PANDA 1.0</b>	156 A2.246	Petrol	999	4	36	785
05/91→07/04	<b>PANDA 1.1</b>	156 C.046	Petrol	1108	4	37	785
02/95→	<b>PANDA 1.1</b>	187 A1.000	Petrol	1108	4	40	789
02/95→07/04	<b>PANDA 1.1</b>	176 B2.000	Petrol	1108	4	38	787
09/03→	<b>PANDA 1.2</b>	188 A4.000	Petrol	1242	4	58	809
06/06→	<b>PANDA 1.2</b>	169 A1.000	Diesel	1248	4	22	773
06/06→	<b>PANDA 1.2</b>	169 A5.000	Diesel	1248	4	24	775
11/09→	<b>PANDA 1.2</b>	169 A4.000	Petrol	1242	4	45	797
04/86→12/92	<b>PANDA 1.3</b>	156 A5.000	Diesel	1302	4	96	845
09/03→	<b>PANDA 1.3</b>	188 A8.000	Diesel	1248	4	25	776
09/03→	<b>PANDA 1.3</b>	188 A9.000	Diesel	1248	4	22	776
02/12→	<b>PANDA 1.3</b>	199 A9.000	Diesel	1248	4	30	780
10/06→	<b>PANDA 1.4</b>	169 A3.000	Petrol	1368	4	65	813
01/10→	<b>PANDA 1.4</b>	350 A1.000	Petrol	1368	4	76	825
01/86→07/92	<b>PANDA VAN 0.8</b>	141 B.000	Petrol	769	4	1	749
01/86→02/92	<b>PANDA VAN 1.0</b>	156 A2.100	Petrol	999	4	36	793
01/86→02/92	<b>PANDA VAN 1.0</b>	156 A3.100	Petrol	999	4	36	790
08/92→02/04	<b>PANDA VAN 1.0</b>	156 A2.246	Petrol	999	4	36	785
05/91→03/95	<b>PANDA VAN 1.1</b>	156 C.046	Petrol	1108	4	37	785
09/00→	<b>PANDA VAN 1.1</b>	187 A1.000	Petrol	1108	4	40	789
09/04→	<b>PANDA VAN 1.2</b>	188 A4.000	Petrol	1242	4	58	809
01/06→	<b>PANDA VAN 1.2</b>	169 A1.000	Diesel	1248	4	22	773
09/10→	<b>PANDA VAN 1.2</b>	169 A4.000	Petrol	1242	4	45	797
03/04→	<b>PANDA VAN 1.3</b>	188 A8.000	Diesel	1248	4	25	776
03/04→	<b>PANDA VAN 1.3</b>	188 A9.000	Diesel	1248	4	22	776
10/09→	<b>PANDA VAN 1.4</b>	350 A1.000	Petrol	1368	4	76	825
01/86→12/90	<b>PENNY VAN 1.1</b>	146 A6.000	Petrol	1116	4	126	874
01/86→12/90	<b>PENNY VAN 1.3</b>	146 A5.000	Petrol	1301	4	521	1185
01/86→12/90	<b>PENNY VAN 1.7</b>	149 B3.000	Diesel	1698	4	301	994
03/85→12/96	<b>PREMIO 1.6</b>	159 A3.000	Petrol	1581	4	541	1199
03/12→	<b>PUNTO 0.9</b>	312 A2.000	Petrol	875	2		922
07/13→	<b>PUNTO 0.9</b>	199 B6.000	Petrol	875	2		920
09/93→09/99	<b>PUNTO 1.1</b>	176 A6.000	Petrol	1108	4	36	787
09/93→09/99	<b>PUNTO 1.1</b>	176 B2.000	Petrol	1108	4	38	787
10/93→09/99	<b>PUNTO 1.2</b>	176 A8.000	Petrol	1242	4	48	799
01/94→09/99	<b>PUNTO 1.2</b>	176 A7.000	Petrol	1242	4	47	798
03/94→09/99	<b>PUNTO 1.2</b>	176 B1.000	Petrol	1242	4	49	800
03/94→09/99	<b>PUNTO 1.2</b>	176 B4.000	Petrol	1242	4	50	799
04/97→09/99	<b>PUNTO 1.2</b>	176 B9.000	Petrol	1242	4	52	801
09/99→	<b>PUNTO 1.2</b>	188 A4.000	Petrol	1242	4	58	809
09/99→	<b>PUNTO 1.2</b>	188 A5.000	Petrol	1242	4	60	810
03/12→	<b>PUNTO 1.2</b>	169 A4.000	Petrol	1242	4	45	797
06/03→	<b>PUNTO 1.3</b>	188 A9.000	Diesel	1248	4	22	776
03/12→	<b>PUNTO 1.3</b>	199 A2.000	Diesel	1248	4	22	777
03/12→	<b>PUNTO 1.3</b>	199 A9.000	Diesel	1248	4	30	780
03/12→	<b>PUNTO 1.3</b>	199 B1.000	Diesel	1248	4	30	780
03/12→	<b>PUNTO 1.3</b>	199 B4.000	Diesel	1248	4	32	782
01/94→09/96	<b>PUNTO 1.4</b>	176 A4.000	Petrol	1372	4	175	914
09/96→09/99	<b>PUNTO 1.4</b>	176 B6.000	Petrol	1372	4	175	914
09/03→	<b>PUNTO 1.4</b>	843 A1.000	Petrol	1368	4	77	818
11/05→	<b>PUNTO 1.4</b>	199 A6.000	Petrol	1368	4	73	818
03/12→	<b>PUNTO 1.4</b>	199 A7.000	Petrol	1368	4	74	819
03/12→	<b>PUNTO 1.4</b>	350 A1.000	Petrol	1368	4	76	825
03/12→	<b>PUNTO 1.4</b>	955 A2.000	Petrol	1368	4	79	821
03/12→	<b>PUNTO 1.4</b>	955 A6.000	Petrol	1368	4	79	821
01/94→04/97	<b>PUNTO 1.6</b>	176 A9.000	Petrol	1581	4	547	1204
01/94→09/99	<b>PUNTO 1.7</b>	176 A3.000	Diesel	1698	4	302	997
01/94→09/99	<b>PUNTO 1.7</b>	176 A5.000	Diesel	1698	4	303	998
04/94→09/97	<b>PUNTO 1.7</b>	176 B3.000	Diesel	1698	4	304	994
09/96→09/99	<b>PUNTO 1.7</b>	176 B7.000	Diesel	1698	4	302	998
09/99→	<b>PUNTO 1.8</b>	183 A1.000	Petrol	1747	4	197	929
09/99→	<b>PUNTO 1.8</b>	188 A6.000	Petrol	1747	4	198	931
09/99→	<b>PUNTO 1.9</b>	188 A2.000	Diesel	1910	4	216	941
09/99→	<b>PUNTO 1.9</b>	188 A3.000	Diesel	1910	4	217	943
10/01→	<b>PUNTO 1.9</b>	188 A7.000	Diesel	1910	4	218	941
06/03→	<b>PUNTO 1.9</b>	188 B2.000	Diesel	1910	4	220	942



ccm

X



9



04/94→06/00	PUNTO CONVERTIBLE 1.2	176 A7.000	Petrol	1242	4	47	798
05/95→06/00	PUNTO CONVERTIBLE 1.2	176 B1.000	Petrol	1242	4	49	800
05/95→06/00	PUNTO CONVERTIBLE 1.2	176 B4.000	Petrol	1242	4	50	799
04/97→06/00	PUNTO CONVERTIBLE 1.2	176 B9.000	Petrol	1242	4	52	801
04/94→04/97	PUNTO CONVERTIBLE 1.6	176 A9.000	Petrol	1581	4	547	1204
10/09→02/12	PUNTO EVO 1.2	169 A4.000	Petrol	1242	4	45	797
10/09→02/12	PUNTO EVO 1.2	199 A4.000	Petrol	1242	4	62	797
07/08→02/12	PUNTO EVO 1.3	199 B2.000	Diesel	1248	4	25	780
10/09→02/12	PUNTO EVO 1.3	199 A2.000	Diesel	1248	4	22	777
10/09→02/12	PUNTO EVO 1.3	199 A3.000	Diesel	1248	4	28	778
10/09→02/12	PUNTO EVO 1.3	199 A9.000	Diesel	1248	4	30	780
10/09→02/12	PUNTO EVO 1.3	199 B1.000	Diesel	1248	4	30	780
10/09→02/12	PUNTO EVO 1.3	199 B4.000	Diesel	1248	4	32	782
10/09→02/12	PUNTO EVO 1.3	223 A9.000	Diesel	1248	4	33	783
07/08→02/12	PUNTO EVO 1.4	199 A8.000	Petrol	1368	4	68	815
07/08→	PUNTO EVO 1.4	955 A8.000	Petrol	1368	4	79	820
06/09→02/12	PUNTO EVO 1.4	350 A1.000	Petrol	1368	4	76	825
07/09→02/12	PUNTO EVO 1.4	199 A7.000	Petrol	1368	4	74	819
10/09→02/12	PUNTO EVO 1.4	955 A2.000	Petrol	1368	4	79	821
10/09→02/12	PUNTO EVO 1.4	955 A6.000	Petrol	1368	4	79	821
10/09→02/12	PUNTO EVO 1.6	955 A3.000	Diesel	1598	4	116	864
10/05→12/11	PUNTO / GRANDE PUNTO 1.2	188 A4.000	Petrol	1242	4	58	809
10/05→	PUNTO / GRANDE PUNTO 1.2	199 A4.000	Petrol	1242	4	62	797
09/10→	PUNTO / GRANDE PUNTO 1.2	169 A4.000	Petrol	1242	4	45	797
10/05→	PUNTO / GRANDE PUNTO 1.3	199 A2.000	Diesel	1248	4	22	777
10/05→	PUNTO / GRANDE PUNTO 1.3	199 A3.000	Diesel	1248	4	28	778
07/08→	PUNTO / GRANDE PUNTO 1.3	199 B2.000	Diesel	1248	4	25	780
04/10→	PUNTO / GRANDE PUNTO 1.3	199 B4.000	Diesel	1248	4	32	782
04/10→	PUNTO / GRANDE PUNTO 1.3	223 A9.000	Diesel	1248	4	33	783
10/05→	PUNTO / GRANDE PUNTO 1.4	199 A6.000	Petrol	1368	4	73	818
10/05→	PUNTO / GRANDE PUNTO 1.4	350 A1.000	Petrol	1368	4	76	825
06/06→	PUNTO / GRANDE PUNTO 1.4	199 A7.000	Petrol	1368	4	74	819
09/07→07/12	PUNTO / GRANDE PUNTO 1.4	198 A1.000	Petrol	1368	4	69	815
09/07→	PUNTO / GRANDE PUNTO 1.4	198 A4.000	Petrol	1368	4	69	815
12/07→	PUNTO / GRANDE PUNTO 1.4	199 A8.000	Petrol	1368	4	68	815
12/07→	PUNTO / GRANDE PUNTO 1.4	955 A8.000	Petrol	1368	4	79	820
07/08→	PUNTO / GRANDE PUNTO 1.6	955 A3.000	Diesel	1598	4	116	864
10/05→	PUNTO / GRANDE PUNTO 1.9	199 A5.000	Diesel	1910	4	229	950
10/05→	PUNTO / GRANDE PUNTO 1.9	939 A1.000	Diesel	1910	4	247	945
06/06→	PUNTO / GRANDE PUNTO 1.9	939 A7.000	Diesel	1910	4	227	960
03/12→	PUNTO VAN 0.9	312 A2.000	Petrol	875	2		922
04/96→02/00	PUNTO VAN 1.1	176 B2.000	Petrol	1108	4	38	787
02/00→10/09	PUNTO VAN 1.2	188 A4.000	Petrol	1242	4	58	809
06/03→10/09	PUNTO VAN 1.3	188 A9.000	Diesel	1248	4	22	776
04/08→	PUNTO VAN 1.3	199 A2.000	Diesel	1248	4	22	777
04/08→	PUNTO VAN 1.3	199 A9.000	Diesel	1248	4	30	780
03/09→	PUNTO VAN 1.3	199 B1.000	Diesel	1248	4	30	780
01/10→02/12	PUNTO VAN 1.3	199 A3.000	Diesel	1248	4	28	778
03/12→	PUNTO VAN 1.3	199 B4.000	Diesel	1248	4	32	782
04/08→	PUNTO VAN 1.4	350 A1.000	Petrol	1368	4	76	825
04/96→02/00	PUNTO VAN 1.7	176 A5.000	Diesel	1698	4	303	998
04/96→02/00	PUNTO VAN 1.7	176 B3.000	Diesel	1698	4	304	994
09/96→09/99	PUNTO VAN 1.7	176 B7.000	Diesel	1698	4	302	998
02/00→10/09	PUNTO VAN 1.9	188 A3.000	Diesel	1910	4	217	943
02/00→10/09	PUNTO VAN 1.9	188 A7.000	Diesel	1910	4	218	941
02/08→	QUBO 1.3	199 A9.000	Diesel	1248	4	30	780
07/10→	QUBO 1.3	199 B1.000	Diesel	1248	4	30	780
02/08→	QUBO 1.4	KFT	Petrol	1360	4	85	837
02/08→	QUBO 1.4	KFV	Petrol	1360	4	85	837
10/09→	QUBO 1.4	350 A1.000	Petrol	1368	4	76	825
09/83→07/86	REGATA 1.3	138 B2.000	Petrol	1302	4	526	1188
09/83→07/89	REGATA 1.3	149 A3.000	Petrol	1301	4	522	1186
09/83→07/89	REGATA 1.3	149 A7.000	Petrol	1302	4	526	1188
09/83→04/85	REGATA 1.5	138 B3.000	Petrol	1498	4	529	1191
12/83→12/87	REGATA 1.5	138 B3.048	Petrol	1498	4	530	1193
12/83→12/87	REGATA 1.5	138 C3.048	Petrol	1498	4	532	1194
05/85→12/87	REGATA 1.5	149 A5.000	Petrol	1498	4	533	1194
07/85→07/89	REGATA 1.5	138 C2.048	Petrol	1499	4	538	1196
07/85→07/89	REGATA 1.5	149 C1.000	Petrol	1499	4	539	1197
10/83→07/89	REGATA 1.6	149 C3.000	Petrol	1585	4	383	1063
10/83→06/90	REGATA 1.6	149 A.000	Petrol	1585	4		1063
10/83→12/90	REGATA 1.6	149 A2.000	Petrol	1585	4	380	1064



ccm

x



9



10/83→12/90	REGATA 1.6	149 A4.000	Petrol	1585	4	381	1065
01/87→07/89	REGATA 1.6	149 C2.000	Petrol	1595	4		1063
09/83→12/86	REGATA 1.7	138 B6.000	Diesel	1714	4	328	1018
05/85→03/89	REGATA 1.7	149 B3.000	Diesel	1698	4	301	994
04/84→07/89	REGATA 1.9	149 A1.000	Diesel	1929	4	306	1001
05/86→07/89	REGATA 1.9	831 D1.000	Diesel	1929	4	322	1012
01/84→07/89	REGATA WEEKEND 1.3	138 B2.000	Petrol	1302	4	526	1188
01/84→04/89	REGATA WEEKEND 1.5	138 B3.000	Petrol	1498	4	529	1191
09/84→07/89	REGATA WEEKEND 1.5	138 B3.048	Petrol	1498	4	530	1193
09/84→07/89	REGATA WEEKEND 1.5	138 C3.048	Petrol	1498	4	532	1194
12/86→07/89	REGATA WEEKEND 1.5	138 C2.048	Petrol	1499	4	538	1196
09/84→12/86	REGATA WEEKEND 1.6	149 A4.000	Petrol	1585	4	381	1065
01/87→07/89	REGATA WEEKEND 1.6	149 C2.000	Petrol	1595	4		1063
01/87→12/90	REGATA WEEKEND 1.6	149 C3.000	Petrol	1585	4	383	1063
01/84→12/89	REGATA WEEKEND 1.7	149 B3.000	Diesel	1698	4	301	994
04/84→07/89	REGATA WEEKEND 1.9	149 A1.000	Diesel	1929	4	306	1001
05/86→07/89	REGATA WEEKEND 1.9	831 D1.000	Diesel	1929	4	322	1012
10/79→09/83	RITMO CONVERTIBLE 1.3	138 A1.000	Petrol	1301	4	519	1184
10/85→12/87	RITMO CONVERTIBLE 1.3	138 B2.000	Petrol	1302	4	526	1188
01/80→07/89	RITMO CONVERTIBLE 1.5	138 A4.000	Petrol	1498	4	528	1191
02/83→01/84	RITMO CONVERTIBLE 1.5	138 A2.000	Petrol	1498	4	527	1191
02/83→01/84	RITMO CONVERTIBLE 1.5	138 C3.048	Petrol	1498	4	532	1194
03/83→12/86	RITMO CONVERTIBLE 1.5	138 B3.000	Petrol	1498	4	529	1191
10/85→12/87	RITMO CONVERTIBLE 1.6	138 AR.000	Petrol	1585	4	379	1058
10/85→12/87	RITMO CONVERTIBLE 1.6	138 AR.048	Petrol	1585	4		1062
09/78→09/82	RITMO I 1.0	127 A6.000	Petrol	1049	4	90	840
01/78→09/82	RITMO I 1.3	138 A1.000	Petrol	1301	4	519	1184
01/81→09/82	RITMO I 1.3	138 A3.000	Petrol	1301	4	520	1184
11/83→08/85	RITMO I 1.3	149 A3.000	Petrol	1301	4	522	1186
11/83→08/85	RITMO I 1.3	149 A7.000	Petrol	1302	4	526	1188
01/78→10/82	RITMO I 1.5	138 A2.000	Petrol	1498	4	527	1191
01/78→10/82	RITMO I 1.5	138 C3.048	Petrol	1498	4	532	1194
01/81→05/87	RITMO I 1.5	138 A4.000	Petrol	1498	4	528	1191
10/85→05/87	RITMO I 1.5	138 C2.048	Petrol	1499	4	538	1196
10/85→05/87	RITMO I 1.5	149 C1.000	Petrol	1499	4	539	1197
05/81→12/82	RITMO I 1.6	138 AR.000	Petrol	1585	4	379	1058
09/85→12/87	RITMO I 1.6	149 C2.000	Petrol	1595	4		1063
10/79→09/82	RITMO I 1.7	138 A5.000	Diesel	1714	4	327	1016
11/81→09/82	RITMO I 2.0	138 AR1.000	Petrol	1995	4	433	1111
10/82→12/87	RITMO II 1.1	138 B.000	Petrol	1116	4	121	871
10/82→12/87	RITMO II 1.1	138 B1.000	Petrol	1116	4	122	873
10/82→12/87	RITMO II 1.1	138 C1.000	Petrol	1116	4	123	873
04/85→12/87	RITMO II 1.1	146 A4.048	Petrol	1116	4	125	873
01/83→04/85	RITMO II 1.3	138 B2.000	Petrol	1302	4	526	1188
01/83→12/87	RITMO II 1.5	138 B3.000	Petrol	1498	4	529	1191
08/85→05/87	RITMO II 1.5	149 A5.000	Petrol	1498	4	533	1194
09/85→12/88	RITMO II 1.5	138 A2.000	Petrol	1498	4	527	1191
09/85→12/88	RITMO II 1.5	138 C2.048	Petrol	1499	4	538	1196
09/85→12/88	RITMO II 1.5	149 C1.000	Petrol	1499	4	539	1197
01/83→12/87	RITMO II 1.6	138 AR.000	Petrol	1585	4	379	1058
01/83→12/87	RITMO II 1.6	149 A4.000	Petrol	1585	4	381	1065
10/82→10/85	RITMO II 1.7	138 B6.000	Diesel	1714	4	328	1018
05/85→12/87	RITMO II 1.7	138 C.000	Diesel	1698	4	298	993
05/85→12/87	RITMO II 1.7	149 B3.000	Diesel	1698	4	301	994
12/85→12/87	RITMO II 1.9	831 D1.000	Diesel	1929	4	322	1012
12/82→12/87	RITMO II 2.0	138 AR1.000	Petrol	1995	4	433	1111
04/83→12/87	RITMO II 2.0	138 AR2.000	Petrol	1995	4	433	1111
01/07→	SCUDO 1.6	9HU	Diesel	1560	4	86	838
01/07→	SCUDO 2.0	RHK	Diesel	1997	4	489	1160
01/07→	SCUDO 2.0	RHR	Diesel	1997	4	493	1162
07/10→	SCUDO 2.0	RHH	Diesel	1997	4	488	1158
04/11→	SCUDO 2.0	RH02	Diesel	1997	4	488	1153
02/96→12/06	SCUDO BOX 1.6	220 A 2.000	Petrol	1581	4	558	1204
01/07→	SCUDO BOX 1.6	9HU	Diesel	1560	4	86	838
02/96→12/06	SCUDO BOX 1.9	D9B	Diesel	1905	4	333	1024
02/96→12/06	SCUDO BOX 1.9	DHX (XUD9TF/L)	Diesel	1905	4	336	1026
02/98→12/06	SCUDO BOX 1.9	D8B	Diesel	1905	4	331	1022
04/98→12/06	SCUDO BOX 1.9	WJZ (DW8)	Diesel	1868	4	294	992
05/99→12/06	SCUDO BOX 2.0	RHW (DW10ATED4)	Diesel	1997	4	495	1162
12/99→12/06	SCUDO BOX 2.0	RHX	Diesel	1997	4	497	1165
05/00→12/06	SCUDO BOX 2.0	RFN (EW10J4)	Petrol	1997	4	485	1156
12/02→12/06	SCUDO BOX 2.0	RHZ	Diesel	1997	4	497	1165





ccm

X



9



01/07→	<b>SCUDO BOX 2.0</b>	RHK	Diesel	1997	4	<b>489</b>	<b>1160</b>
01/07→	<b>SCUDO BOX 2.0</b>	RHR	Diesel	1997	4	<b>493</b>	<b>1162</b>
07/10→	<b>SCUDO BOX 2.0</b>	RHH	Diesel	1997	4	<b>488</b>	<b>1158</b>
05/11→	<b>SCUDO BOX 2.0</b>	RH02	Diesel	1997	4	<b>488</b>	<b>1153</b>
02/96→12/06	<b>SCUDO COMBINATO 1.6</b>	220 A 2.000	Petrol	1581	4	<b>558</b>	<b>1204</b>
02/96→04/98	<b>SCUDO COMBINATO 1.9</b>	D9B	Diesel	1905	4	<b>333</b>	<b>1024</b>
02/96→12/06	<b>SCUDO COMBINATO 1.9</b>	D8B	Diesel	1905	4	<b>331</b>	<b>1022</b>
02/96→12/06	<b>SCUDO COMBINATO 1.9</b>	DHX (XUD9TF/L)	Diesel	1905	4	<b>336</b>	<b>1026</b>
04/98→12/06	<b>SCUDO COMBINATO 1.9</b>	WJZ (DW8)	Diesel	1868	4	<b>294</b>	<b>992</b>
05/99→12/06	<b>SCUDO COMBINATO 2.0</b>	RHW (DW10ATED4)	Diesel	1997	4	<b>495</b>	<b>1162</b>
12/99→12/06	<b>SCUDO COMBINATO 2.0</b>	RHZ	Diesel	1997	4	<b>497</b>	<b>1165</b>
06/00→12/06	<b>SCUDO COMBINATO 2.0</b>	RFN (EW10J4)	Petrol	1997	4	<b>485</b>	<b>1156</b>
01/04→12/06	<b>SCUDO COMBINATO 2.0</b>	RHX	Diesel	1997	4	<b>497</b>	<b>1165</b>
01/07→	<b>SCUDO PLATFORM/CHASSIS 1.6</b>	9HU	Diesel	1560	4	<b>86</b>	<b>838</b>
01/07→	<b>SCUDO PLATFORM/CHASSIS 2.0</b>	DW10BTED4	Diesel	1997	4	<b>483</b>	<b>1154</b>
01/07→	<b>SCUDO PLATFORM/CHASSIS 2.0</b>	RHK	Diesel	1997	4	<b>489</b>	<b>1160</b>
01/07→	<b>SCUDO PLATFORM/CHASSIS 2.0</b>	RHR	Diesel	1997	4	<b>493</b>	<b>1162</b>
07/10→	<b>SCUDO PLATFORM/CHASSIS 2.0</b>	RHH	Diesel	1997	4	<b>488</b>	<b>1158</b>
05/11→	<b>SCUDO PLATFORM/CHASSIS 2.0</b>	RH02	Diesel	1997	4	<b>488</b>	<b>1153</b>
06/06→	<b>SEDICI 1.6</b>	M16A	Petrol	1586	4	<b>111</b>	<b>858</b>
06/06→	<b>SEDICI 1.9</b>	D19AA	Diesel	1910	4	<b>257</b>	<b>950</b>
06/06→	<b>SEDICI 2.0</b>	D20AA	Diesel	1956	4	<b>340</b>	<b>1032</b>
01/98→01/10	<b>SEICENTO 0.9</b>	1170 A1.046	Petrol	899	4	<b>6</b>	<b>756</b>
01/98→01/10	<b>SEICENTO 1.1</b>	176 B2.000	Petrol	1108	4	<b>38</b>	<b>787</b>
01/98→01/10	<b>SEICENTO 1.1</b>	187 A1.000	Petrol	1108	4	<b>40</b>	<b>789</b>
01/98→01/10	<b>SEICENTO VAN 0.9</b>	1170 A1.046	Petrol	899	4	<b>6</b>	<b>756</b>
01/98→01/10	<b>SEICENTO VAN 1.1</b>	176 B2.000	Petrol	1108	4	<b>38</b>	<b>787</b>
09/00→	<b>SIENA 1.0</b>	178 D9.011	Petrol	999	4	<b>34</b>	
09/98→	<b>SIENA 1.2</b>	178 B5.000	Petrol	1242	4	<b>53</b>	<b>803</b>
09/01→	<b>SIENA 1.2</b>	178 C4.066	Petrol	1242	4	<b>55</b>	<b>804</b>
09/01→	<b>SIENA 1.2</b>	188 A4.000	Petrol	1242	4	<b>58</b>	<b>809</b>
09/01→	<b>SIENA 1.2</b>	188 A5.000	Petrol	1242	4	<b>60</b>	<b>810</b>
03/04→05/05	<b>SIENA 1.2</b>	178 E9.011	Petrol	1242	4		<b>806</b>
09/03→	<b>SIENA 1.3</b>	188 A9.000	Diesel	1248	4	<b>22</b>	<b>776</b>
04/96→	<b>SIENA 1.4</b>	178 B2.000	Petrol	1372	4	<b>176</b>	<b>910</b>
04/96→	<b>SIENA 1.4</b>	178 B2.016	Petrol	1372	4	<b>177</b>	<b>910</b>
06/04→10/07	<b>SIENA 1.4</b>	178 F3.011	Petrol	1368	4		<b>814</b>
09/98→	<b>SIENA 1.6</b>	178 B3.000	Petrol	1581	4	<b>548</b>	<b>1205</b>
11/00→	<b>SIENA 1.6</b>	182 B6.000	Petrol	1596	4	<b>181</b>	<b>916</b>
02/06→	<b>SIENA 1.7</b>	176 A3.000	Diesel	1698	4	<b>302</b>	<b>997</b>
06/04→	<b>SIENA 1.8</b>	93313090-7U	Petrol	1796	4	<b>183</b>	<b>919</b>
11/00→	<b>SIENA 1.9</b>	223 A6.000	Diesel	1910	4	<b>230</b>	<b>951</b>
02/02→11/06	<b>STILO 1.2</b>	188 A5.000	Petrol	1242	4	<b>60</b>	<b>810</b>
01/04→11/06	<b>STILO 1.4</b>	843 A1.000	Petrol	1368	4	<b>77</b>	<b>818</b>
03/05→11/06	<b>STILO 1.4</b>	192 B2.000	Petrol	1368	4	<b>66</b>	<b>813</b>
10/01→11/06	<b>STILO 1.6</b>	182 B6.000	Petrol	1596	4	<b>181</b>	<b>916</b>
05/05→11/06	<b>STILO 1.6</b>	192 B3.000	Petrol	1598	4	<b>114</b>	<b>862</b>
10/01→11/06	<b>STILO 1.8</b>	192 A4.000	Petrol	1747	4	<b>199</b>	<b>931</b>
10/01→11/06	<b>STILO 1.9</b>	192 A1.000	Diesel	1910	4	<b>221</b>	<b>945</b>
10/01→11/06	<b>STILO 1.9</b>	937 A7.000	Diesel	1910	4	<b>244</b>	<b>957</b>
02/02→11/06	<b>STILO 1.9</b>	192 A3.000	Diesel	1910	4	<b>222</b>	<b>941</b>
09/03→11/06	<b>STILO 1.9</b>	937 A4.000	Diesel	1910	4	<b>239</b>	<b>946</b>
01/04→11/06	<b>STILO 1.9</b>	192 A5.000	Diesel	1910	4	<b>223</b>	<b>946</b>
04/04→11/06	<b>STILO 1.9</b>	192 B1.000	Diesel	1910	4	<b>223</b>	<b>946</b>
09/04→11/06	<b>STILO 1.9</b>	192 B5.000	Diesel	1910	4	<b>228</b>	<b>948</b>
09/05→11/06	<b>STILO 1.9</b>	192 A8.000	Diesel	1910	4	<b>225</b>	<b>947</b>
09/05→11/06	<b>STILO 1.9</b>	192 A9.000	Diesel	1910	4	<b>226</b>	<b>948</b>
09/05→11/06	<b>STILO 1.9</b>	937 A5.000	Diesel	1910	4	<b>240</b>	<b>946</b>
10/01→11/06	<b>STILO 2.4</b>	192 A2.000	Petrol	2446	5	<b>354</b>	<b>1044</b>
01/04→08/08	<b>STILO MULTI WAGON 1.4</b>	843 A1.000	Petrol	1368	4	<b>77</b>	<b>818</b>
03/05→08/08	<b>STILO MULTI WAGON 1.4</b>	192 B2.000	Petrol	1368	4	<b>66</b>	<b>813</b>
01/03→08/08	<b>STILO MULTI WAGON 1.6</b>	182 B6.000	Petrol	1596	4	<b>181</b>	<b>916</b>
03/05→12/07	<b>STILO MULTI WAGON 1.6</b>	192 B3.000	Petrol	1598	4	<b>114</b>	<b>862</b>
01/03→08/08	<b>STILO MULTI WAGON 1.8</b>	192 A4.000	Petrol	1747	4	<b>199</b>	<b>931</b>
01/03→08/08	<b>STILO MULTI WAGON 1.9</b>	192 A1.000	Diesel	1910	4	<b>221</b>	<b>945</b>
01/03→08/08	<b>STILO MULTI WAGON 1.9</b>	192 A3.000	Diesel	1910	4	<b>222</b>	<b>941</b>
01/03→08/08	<b>STILO MULTI WAGON 1.9</b>	937 A7.000	Diesel	1910	4	<b>244</b>	<b>957</b>
09/03→08/08	<b>STILO MULTI WAGON 1.9</b>	937 A4.000	Diesel	1910	4	<b>239</b>	<b>946</b>
01/04→08/08	<b>STILO MULTI WAGON 1.9</b>	192 A5.000	Diesel	1910	4	<b>223</b>	<b>946</b>
04/04→08/08	<b>STILO MULTI WAGON 1.9</b>	192 B1.000	Diesel	1910	4	<b>223</b>	<b>946</b>
09/04→08/08	<b>STILO MULTI WAGON 1.9</b>	192 B5.000	Diesel	1910	4	<b>228</b>	<b>948</b>
09/05→08/08	<b>STILO MULTI WAGON 1.9</b>	192 A8.000	Diesel	1910	4	<b>225</b>	<b>947</b>



ccm



9



09/05→08/08	STILO MULTI WAGON 1.9	192 A9.000	Diesel	1910	4	226	948
09/05→08/08	STILO MULTI WAGON 1.9	937 A5.000	Diesel	1910	4	240	946
06/99→	STRADA PICKUP 1.2	178 B5.000	Petrol	1242	4	53	803
04/03→	STRADA PICKUP 1.2	188 A4.000	Petrol	1242	4	58	809
05/06→	STRADA PICKUP 1.3	223 A9.000	Diesel	1248	4	33	783
10/10→	STRADA PICKUP 1.3	199 B1.000	Diesel	1248	4	30	780
06/99→	STRADA PICKUP 1.7	176 A3.000	Diesel	1698	4	302	997
12/00→	STRADA PICKUP 1.9	223 A6.000	Diesel	1910	4	230	951
04/03→	STRADA PICKUP 1.9	188 A2.000	Diesel	1910	4	216	941
03/89→03/94	TALENTO BOX 1.9	149 B1.000	Diesel	1929	4	307	1001
03/89→03/94	TALENTO BOX 2.0	170 B	Petrol	1971	4	574	1224
03/89→03/94	TALENTO BUS 1.9	149 B1.000	Diesel	1929	4	307	1001
03/89→03/94	TALENTO BUS 2.0	170 B	Petrol	1971	4	574	1224
03/89→03/94	TALENTO PLATFORM/CHASSIS 1.9	149 B1.000	Diesel	1929	4	307	1001
03/89→03/94	TALENTO PLATFORM/CHASSIS 2.0	170 B	Petrol	1971	4	574	1224
03/91→08/96	TEMPRA 1.4	159 A2.000	Petrol	1372	4	172	911
03/92→08/96	TEMPRA 1.4	160 A1.046	Petrol	1372	4	173	912
03/92→08/96	TEMPRA 1.4	836 A4.000	Petrol	1372	4	172	912
03/90→04/93	TEMPRA 1.6	159 A3.000	Petrol	1581	4	541	1199
04/90→08/96	TEMPRA 1.6	159 A3.048	Petrol	1581	4	543	1200
06/90→07/92	TEMPRA 1.6	159 A3.046	Petrol	1581	4	542	1199
06/92→08/96	TEMPRA 1.6	835 C1.000	Petrol	1581	4	562	1215
06/94→08/96	TEMPRA 1.6	159 B9.000	Petrol	1581	4	545	1202
03/90→08/96	TEMPRA 1.8	159 A4.000	Petrol	1756	4	398	1080
03/92→08/96	TEMPRA 1.8	159 A4.046	Petrol	1756	4	399	1080
09/93→08/96	TEMPRA 1.8	835 C2.000	Petrol	1756	4	403	1085
09/93→08/96	TEMPRA 1.8	835 C4.000	Petrol	1756	4	406	1086
10/94→08/96	TEMPRA 1.8	836 A5.000	Petrol	1756	4	409	1089
05/90→08/96	TEMPRA 1.9	160 A6.000	Diesel	1929	4	311	1006
05/90→08/96	TEMPRA 1.9	160 D1.000	Diesel	1929	4	315	1006
07/91→08/96	TEMPRA 1.9	149 A1.000	Diesel	1929	4	306	1001
07/91→08/96	TEMPRA 1.9	160 A7.000	Diesel	1929	4	313	1001
07/92→08/96	TEMPRA 1.9	160 B6.046	Diesel	1929	4	314	1006
10/90→08/96	TEMPRA 2.0	159 A6.046	Petrol	1995	4	441	1123
03/91→08/96	TEMPRA S.W. 1.4	159 A2.000	Petrol	1372	4	172	911
10/92→08/96	TEMPRA S.W. 1.4	160 A1.046	Petrol	1372	4	173	912
10/92→08/96	TEMPRA S.W. 1.4	836 A4.000	Petrol	1372	4	172	912
10/90→08/96	TEMPRA S.W. 1.6	159 A3.046	Petrol	1581	4	542	1199
10/90→08/96	TEMPRA S.W. 1.6	835 C1.000	Petrol	1581	4	562	1215
12/90→04/93	TEMPRA S.W. 1.6	159 A3.000	Petrol	1581	4	541	1199
10/92→08/96	TEMPRA S.W. 1.6	159 A3.048	Petrol	1581	4	543	1200
06/94→08/96	TEMPRA S.W. 1.6	159 B9.000	Petrol	1581	4	545	1202
03/90→08/96	TEMPRA S.W. 1.8	159 A4.000	Petrol	1756	4	398	1080
03/92→12/93	TEMPRA S.W. 1.8	159 A4.046	Petrol	1756	4	399	1080
09/93→08/96	TEMPRA S.W. 1.8	835 C2.000	Petrol	1756	4	403	1085
09/93→08/96	TEMPRA S.W. 1.8	835 C4.000	Petrol	1756	4	406	1086
10/94→08/96	TEMPRA S.W. 1.8	836 A5.000	Petrol	1756	4	409	1089
07/91→02/95	TEMPRA S.W. 1.9	160 A6.000	Diesel	1929	4	311	1006
07/91→02/95	TEMPRA S.W. 1.9	160 D1.000	Diesel	1929	4	315	1006
07/91→08/96	TEMPRA S.W. 1.9	149 A1.000	Diesel	1929	4	306	1001
07/91→08/96	TEMPRA S.W. 1.9	160 A7.000	Diesel	1929	4	313	1001
03/92→06/93	TEMPRA S.W. 1.9	160 B6.046	Diesel	1929	4	314	1006
01/91→03/95	TEMPRA S.W. 2.0	159 A6.046	Petrol	1995	4	441	1123
01/88→10/91	TIPO 1.1	160 A3.000	Petrol	1108	4	37	786
07/87→12/89	TIPO 1.4	160 A1.000	Petrol	1372	4	172	911
07/87→12/89	TIPO 1.4	160 A1.048	Petrol	1372	4	174	912
05/89→04/95	TIPO 1.4	159 A2.000	Petrol	1372	4	172	911
05/89→04/95	TIPO 1.4	160 A1.046	Petrol	1372	4	173	912
05/89→04/95	TIPO 1.4	836 A4.000	Petrol	1372	4	172	912
01/88→10/92	TIPO 1.6	160 A2.000	Petrol	1581	4	546	1203
02/88→05/91	TIPO 1.6	149 C2.046	Petrol	1595	4	392	1063
05/89→10/95	TIPO 1.6	159 A3.000	Petrol	1581	4	541	1199
07/90→01/93	TIPO 1.6	159 A3.046	Petrol	1581	4	542	1199
10/92→04/95	TIPO 1.6	159 A3.048	Petrol	1581	4	543	1200
10/92→04/95	TIPO 1.6	835 C1.000	Petrol	1581	4	562	1215
01/88→10/95	TIPO 1.7	149 B4.000	Diesel	1697	4	296	994
11/89→06/92	TIPO 1.8	160 A5.000	Petrol	1756	4	400	1081
10/90→06/93	TIPO 1.8	159 A4.046	Petrol	1756	4	399	1080
10/90→10/95	TIPO 1.8	159 A4.000	Petrol	1756	4	398	1080
03/93→10/95	TIPO 1.8	836 A5.000	Petrol	1756	4	409	1089
04/93→04/95	TIPO 1.8	835 C2.000	Petrol	1756	4	403	1085
09/93→04/95	TIPO 1.8	835 C4.000	Petrol	1756	4	406	1086



ccm

X



9



09/90→04/95	<b>TIPO 1.9</b>	160 A6.000	Diesel	1929	4	311	1006
09/90→04/95	<b>TIPO 1.9</b>	160 A6.046	Diesel	1929	4	312	1006
09/90→04/95	<b>TIPO 1.9</b>	160 D1.000	Diesel	1929	4	315	1006
07/91→08/96	<b>TIPO 1.9</b>	149 A1.000	Diesel	1929	4	306	1001
07/91→08/96	<b>TIPO 1.9</b>	160 A7.000	Diesel	1929	4	313	1001
03/92→06/93	<b>TIPO 1.9</b>	160 B6.046	Diesel	1929	4	314	1006
03/90→04/95	<b>TIPO 2.0</b>	159 A6.046	Petrol	1995	4	441	1123
06/90→10/92	<b>TIPO 2.0</b>	159 A5.046	Petrol	1995	4	440	1122
07/91→04/95	<b>TIPO 2.0</b>	160 A8.046	Petrol	1995	4	442	1124
03/93→04/95	<b>TIPO 2.0</b>	836 A3.000	Petrol	1995	4	476	1121
03/93→04/95	<b>TIPO 2.0</b>	836 A3.011	Petrol	1995	4	477	1146
05/97→08/02	<b>ULYSSE 1.8</b>	LFW	Petrol	1761	4	330	1021
02/95→08/02	<b>ULYSSE 1.9</b>	DHX (XUD9TF/L)	Diesel	1905	4	336	1026
06/94→08/02	<b>ULYSSE 2.0</b>	RFU (XU10J2C)	Petrol	1998	4	510	1176
06/94→08/02	<b>ULYSSE 2.0</b>	RGX (XU10J2CTE)	Petrol	1998	4	514	1179
05/98→09/00	<b>ULYSSE 2.0</b>	RFV	Petrol	1998	4	512	1178
05/99→08/06	<b>ULYSSE 2.0</b>	RHW (DW10ATED4)	Diesel	1997	4	495	1162
10/99→08/02	<b>ULYSSE 2.0</b>	RHZ	Diesel	1997	4	497	1165
09/00→06/11	<b>ULYSSE 2.0</b>	RFN (EW10J4)	Petrol	1997	4	485	1156
05/03→08/06	<b>ULYSSE 2.0</b>	RHM (DW10ATED4)	Diesel	1997	4	490	1161
05/06→06/11	<b>ULYSSE 2.0</b>	RHK	Diesel	1997	4	489	1160
05/06→06/11	<b>ULYSSE 2.0</b>	RHR	Diesel	1997	4	493	1162
03/96→10/99	<b>ULYSSE 2.1</b>	P8C	Diesel	2088	4	499	1167
08/02→08/06	<b>ULYSSE 2.2</b>	4HW (DW12ATED4)	Diesel	2179	4	505	1169
03/08→06/11	<b>ULYSSE 2.2</b>	4HP	Diesel	2179	4	501	1153
03/08→06/11	<b>ULYSSE 2.2</b>	4HR	Diesel	2179	4	501	1168
03/08→06/11	<b>ULYSSE 2.2</b>	4HS	Diesel	2179	4	501	1168
03/08→06/11	<b>ULYSSE 2.2</b>	4HT (DW12BTED4)	Diesel	2179	4	502	1168
08/02→06/11	<b>ULYSSE 3.0</b>	XFW	Petrol	2946	V6	572	1223
03/83→09/92	<b>UNO 0.9</b>	146 A.000	Petrol	903	4	11	761
03/83→09/92	<b>UNO 0.9</b>	146 A1.000	Petrol	903	4	13	762
04/84→08/00	<b>UNO 1.0</b>	156 A2.246	Petrol	999	4	36	785
06/86→12/93	<b>UNO 1.0</b>	156 A2.048	Petrol	999	4	36	790
06/86→12/93	<b>UNO 1.0</b>	156 A2.100	Petrol	999	4	36	793
06/89→02/92	<b>UNO 1.0</b>	156 A2.000	Petrol	999	4	43	793
01/83→08/89	<b>UNO 1.1</b>	138 B.000	Petrol	1116	4	121	871
05/85→08/89	<b>UNO 1.1</b>	146 A4.048	Petrol	1116	4	125	873
01/86→12/89	<b>UNO 1.1</b>	146 A4.044	Petrol	1116	4	124	873
04/89→06/06	<b>UNO 1.1</b>	160 A3.000	Petrol	1108	4	37	786
01/90→12/93	<b>UNO 1.1</b>	156 C.046	Petrol	1108	4	37	785
06/92→12/93	<b>UNO 1.1</b>	146 C3.000	Petrol	1116	4	128	876
01/83→04/85	<b>UNO 1.3</b>	138 B2.000	Petrol	1302	4	526	1188
06/83→03/92	<b>UNO 1.3</b>	127 A5.000	Diesel	1302	4	95	846
06/83→03/92	<b>UNO 1.3</b>	146 B1.000	Diesel	1301	4	94	845
04/85→08/89	<b>UNO 1.3</b>	146 A2.000	Petrol	1301	4	166	907
05/85→08/89	<b>UNO 1.3</b>	149 A7.000	Petrol	1302	4	526	1188
01/87→12/87	<b>UNO 1.3</b>	146 A2.146	Petrol	1301	4	167	908
09/89→03/91	<b>UNO 1.3</b>	146 A2.246	Petrol	1301	4	167	907
10/86→10/90	<b>UNO 1.4</b>	146 B.000	Diesel	1367	4	106	853
10/86→10/90	<b>UNO 1.4</b>	146 B3.000	Diesel	1367	4	106	853
10/88→08/00	<b>UNO 1.4</b>	146 A8.000	Petrol	1372	4	168	909
09/89→10/92	<b>UNO 1.4</b>	160 A1.048	Petrol	1372	4	174	912
09/89→09/93	<b>UNO 1.4</b>	146 A8.046	Petrol	1372	4	169	909
09/89→12/93	<b>UNO 1.4</b>	146 C1.000	Petrol	1372	4	170	910
09/89→07/96	<b>UNO 1.4</b>	160 A1.046	Petrol	1372	4	173	912
10/85→12/93	<b>UNO 1.5</b>	138 C2.048	Petrol	1499	4	538	1196
10/85→12/93	<b>UNO 1.5</b>	149 C1.000	Petrol	1499	4	539	1197
12/89→12/93	<b>UNO 1.6</b>	159 A3.046	Petrol	1581	4	542	1199
12/92→12/95	<b>UNO 1.6</b>	159 A3.048	Petrol	1581	4	543	1200
07/86→08/89	<b>UNO 1.7</b>	149 B3.000	Diesel	1698	4	301	994
09/89→08/00	<b>UNO 1.7</b>	146 B2.000	Diesel	1698	4	299	994
09/89→03/94	<b>UNO 1.9</b>	149 B5.046	Diesel	1929	4	308	1002
02/88→07/96	<b>UNO BOX 0.9</b>	146 A.000	Petrol	903	4	11	761
02/88→07/96	<b>UNO BOX 0.9</b>	146 A1.000	Petrol	903	4	13	762
02/88→02/92	<b>UNO BOX 1.1</b>	146 A4.048	Petrol	1116	4	125	873
02/88→02/92	<b>UNO BOX 1.1</b>	146 A6.000	Petrol	1116	4	126	874
02/88→02/92	<b>UNO BOX 1.7</b>	146 B2.000	Diesel	1698	4	299	994
02/88→02/92	<b>UNO BOX 1.7</b>	149 B4.046	Diesel	1697	4	297	993



ccm

x



9



01/78→12/89	<b>DAILY I BOX BODY / ESTATE 2.4</b>	8140.61.200	Diesel	2445	4	<b>620</b>	<b>1262</b>
01/85→12/89	<b>DAILY I BOX BODY / ESTATE 2.4</b>	8140.21.200	Diesel	2445	4	<b>614</b>	<b>1252</b>
01/85→12/89	<b>DAILY I BOX BODY / ESTATE 2.5</b>	8140.27 S	Diesel	2445	4	<b>617</b>	<b>1258</b>
01/78→12/89	<b>DAILY I PLATFORM/CHASSIS 2.4</b>	8140.61.200	Diesel	2445	4	<b>620</b>	<b>1262</b>
01/85→12/89	<b>DAILY I PLATFORM/CHASSIS 2.4</b>	8140.21.200	Diesel	2445	4	<b>614</b>	<b>1252</b>
01/85→12/89	<b>DAILY I PLATFORM/CHASSIS 2.5</b>	8140.27 S	Diesel	2445	4	<b>617</b>	<b>1258</b>
01/89→04/96	<b>DAILY II BOX BODY / ESTATE 2.5</b>	8140.27.2720	Diesel	2499	4	<b>641</b>	<b>1284</b>
01/89→05/96	<b>DAILY II BOX BODY / ESTATE 2.5</b>	8140.27.2700	Diesel	2499	4	<b>641</b>	<b>1283</b>
01/89→08/98	<b>DAILY II BOX BODY / ESTATE 2.5</b>	8140.47R	Diesel	2499	4	<b>658</b>	<b>1297</b>
01/89→08/98	<b>DAILY II BOX BODY / ESTATE 2.5</b>	8140.47R.2790	Diesel	2499	4	<b>660</b>	<b>1298</b>
01/89→08/98	<b>DAILY II BOX BODY / ESTATE 2.5</b>	8140.67F.	Diesel	2499	4	<b>663</b>	<b>1302</b>
01/89→08/98	<b>DAILY II BOX BODY / ESTATE 2.5</b>	8140.67F.3710	Diesel	2499	4		<b>1300</b>
01/89→08/98	<b>DAILY II BOX BODY / ESTATE 2.5</b>	8140.67F.3711	Diesel	2499	4		<b>1300</b>
01/89→08/98	<b>DAILY II BOX BODY / ESTATE 2.5</b>	8140.67F.3713	Diesel	2499	4		<b>1300</b>
01/89→08/98	<b>DAILY II BOX BODY / ESTATE 2.5</b>	8140.67F.3721	Diesel	2499	4		<b>1300</b>
01/89→08/98	<b>DAILY II BOX BODY / ESTATE 2.5</b>	8140.07.2700	Diesel	2499	4	<b>635</b>	<b>1275</b>
01/89→08/98	<b>DAILY II BOX BODY / ESTATE 2.5</b>	8140.07.2712	Diesel	2499	4	<b>637</b>	<b>1278</b>
01/90→04/96	<b>DAILY II BOX BODY / ESTATE 2.5</b>	8140.47.2700	Diesel	2499	4	<b>652</b>	<b>1291</b>
06/90→04/96	<b>DAILY II BOX BODY / ESTATE 2.5</b>	8140.47.2711	Diesel	2499	4	<b>641</b>	<b>1292</b>
06/90→04/96	<b>DAILY II BOX BODY / ESTATE 2.5</b>	8140.47.2721	Diesel	2499	4	<b>653</b>	<b>1293</b>
01/91→08/98	<b>DAILY II BOX BODY / ESTATE 2.5</b>	8140.67F.3701	Diesel	2499	4		<b>1300</b>
09/96→08/98	<b>DAILY II BOX BODY / ESTATE 2.5</b>	8140.97.2781	Diesel	2499	4	<b>664</b>	<b>1303</b>
02/95→05/99	<b>DAILY II BOX BODY / ESTATE 2.8</b>	8140.43.	Diesel	2798	4	<b>717</b>	<b>1333</b>
01/96→05/99	<b>DAILY II BOX BODY / ESTATE 2.8</b>	8140.23.	Diesel	2798	4	<b>710</b>	<b>1329</b>
09/98→05/99	<b>DAILY II BOX BODY / ESTATE 2.8</b>	8140.63.	Diesel	2798	4	<b>734</b>	<b>1343</b>
06/90→04/96	<b>DAILY II BUS 2.5</b>	8140.47.2711	Diesel	2499	4	<b>641</b>	<b>1292</b>
06/90→04/96	<b>DAILY II BUS 2.5</b>	8140.47.2721	Diesel	2499	4	<b>653</b>	<b>1293</b>
01/91→12/96	<b>DAILY II BUS 2.5</b>	8140.27.2720	Diesel	2499	4	<b>641</b>	<b>1284</b>
05/96→05/99	<b>DAILY II BUS 2.8</b>	8140.23.	Diesel	2798	4	<b>710</b>	<b>1329</b>
05/96→05/99	<b>DAILY II BUS 2.8</b>	8140.43.	Diesel	2798	4	<b>717</b>	<b>1333</b>
01/89→04/96	<b>DAILY II DUMPTRUCK 2.5</b>	8140.47R.2790	Diesel	2499	4	<b>660</b>	<b>1298</b>
01/89→04/96	<b>DAILY II DUMPTRUCK 2.5</b>	8140.27.2700	Diesel	2499	4	<b>641</b>	<b>1283</b>
06/90→04/96	<b>DAILY II DUMPTRUCK 2.5</b>	8140.47.2711	Diesel	2499	4	<b>641</b>	<b>1292</b>
06/90→04/96	<b>DAILY II DUMPTRUCK 2.5</b>	8140.47.2721	Diesel	2499	4	<b>653</b>	<b>1293</b>
05/91→04/96	<b>DAILY II DUMPTRUCK 2.5</b>	8140.47.2700	Diesel	2499	4	<b>652</b>	<b>1291</b>
01/92→04/96	<b>DAILY II DUMPTRUCK 2.5</b>	8140.27.2720	Diesel	2499	4	<b>641</b>	<b>1284</b>
05/96→05/99	<b>DAILY II DUMPTRUCK 2.8</b>	8140.23.	Diesel	2798	4	<b>710</b>	<b>1329</b>
05/96→05/99	<b>DAILY II DUMPTRUCK 2.8</b>	8140.43.	Diesel	2798	4	<b>717</b>	<b>1333</b>
09/98→05/99	<b>DAILY II DUMPTRUCK 2.8</b>	8140.63.	Diesel	2798	4	<b>734</b>	<b>1343</b>
01/89→04/96	<b>DAILY II PLATFORM/CHASSIS 2.5</b>	8140.27.2700	Diesel	2499	4	<b>641</b>	<b>1283</b>
01/89→04/96	<b>DAILY II PLATFORM/CHASSIS 2.5</b>	8140.27.2720	Diesel	2499	4	<b>641</b>	<b>1284</b>
01/89→12/96	<b>DAILY II PLATFORM/CHASSIS 2.5</b>	8140.47R	Diesel	2499	4	<b>658</b>	<b>1297</b>
01/89→12/96	<b>DAILY II PLATFORM/CHASSIS 2.5</b>	8140.47R.2790	Diesel	2499	4	<b>660</b>	<b>1298</b>
01/89→12/96	<b>DAILY II PLATFORM/CHASSIS 2.5</b>	8140.97.2781	Diesel	2499	4	<b>664</b>	<b>1303</b>
01/89→08/98	<b>DAILY II PLATFORM/CHASSIS 2.5</b>	8140.67F.	Diesel	2499	4	<b>663</b>	<b>1302</b>
01/89→08/98	<b>DAILY II PLATFORM/CHASSIS 2.5</b>	8140.07.2700	Diesel	2499	4	<b>635</b>	<b>1275</b>
01/89→08/98	<b>DAILY II PLATFORM/CHASSIS 2.5</b>	8140.07.2712	Diesel	2499	4	<b>637</b>	<b>1278</b>
01/90→04/96	<b>DAILY II PLATFORM/CHASSIS 2.5</b>	8140.47.2700	Diesel	2499	4	<b>652</b>	<b>1291</b>
06/90→04/96	<b>DAILY II PLATFORM/CHASSIS 2.5</b>	8140.47.2711	Diesel	2499	4	<b>641</b>	<b>1292</b>
06/90→04/96	<b>DAILY II PLATFORM/CHASSIS 2.5</b>	8140.47.2721	Diesel	2499	4	<b>653</b>	<b>1293</b>
01/92→08/98	<b>DAILY II PLATFORM/CHASSIS 2.5</b>	8140.67F.3710	Diesel	2499	4		<b>1300</b>
01/92→08/98	<b>DAILY II PLATFORM/CHASSIS 2.5</b>	8140.67F.3711	Diesel	2499	4		<b>1300</b>
01/92→08/98	<b>DAILY II PLATFORM/CHASSIS 2.5</b>	8140.67F.3713	Diesel	2499	4		<b>1300</b>
01/92→08/98	<b>DAILY II PLATFORM/CHASSIS 2.5</b>	8140.67F.3721	Diesel	2499	4		<b>1300</b>
01/96→05/99	<b>DAILY II PLATFORM/CHASSIS 2.8</b>	8140.23.	Diesel	2798	4	<b>710</b>	<b>1329</b>
05/96→05/99	<b>DAILY II PLATFORM/CHASSIS 2.8</b>	8140.43.	Diesel	2798	4	<b>717</b>	<b>1333</b>
09/98→05/99	<b>DAILY II PLATFORM/CHASSIS 2.8</b>	8140.63.	Diesel	2798	4	<b>734</b>	<b>1343</b>
09/02→	<b>DAILY III BOX BODY / ESTATE 2.3</b>	F1AE0481A	Diesel	2287	4	<b>582</b>	<b>1229</b>
09/02→	<b>DAILY III BOX BODY / ESTATE 2.3</b>	F1AE0481B	Diesel	2287	4	<b>583</b>	<b>1229</b>
01/05→04/06	<b>DAILY III BOX BODY / ESTATE 2.3</b>	F1AE0481M	Diesel	2287	4	<b>588</b>	<b>1232</b>
11/97→07/07	<b>DAILY III BOX BODY / ESTATE 2.8</b>	8140.23.	Diesel	2798	4	<b>710</b>	<b>1329</b>
05/99→	<b>DAILY III BOX BODY / ESTATE 2.8</b>	8140.43C	Diesel	2798	4	<b>724</b>	<b>1336</b>
05/99→	<b>DAILY III BOX BODY / ESTATE 2.8</b>	8140.43S	Diesel	2798	4	<b>732</b>	<b>1339</b>
05/99→	<b>DAILY III BOX BODY / ESTATE 2.8</b>	8140.63.	Diesel	2798	4	<b>734</b>	<b>1343</b>
01/01→	<b>DAILY III BOX BODY / ESTATE 2.8</b>	8140.43N	Diesel	2798	4	<b>727</b>	<b>1339</b>
11/01→04/06	<b>DAILY III BOX BODY / ESTATE 2.8</b>	8140.43R	Diesel	2798	4	<b>730</b>	<b>1341</b>
07/99→04/06	<b>DAILY III BOX BODY / ESTATE 3.0</b>	F1CE0481A	Diesel	2998	4	<b>742</b>	<b>1352</b>
09/04→04/06	<b>DAILY III BOX BODY / ESTATE 3.0</b>	F1CE0481B	Diesel	2998	4	<b>742</b>	<b>1352</b>
09/02→	<b>DAILY III PLATFORM/CHASSIS 2.3</b>	F1AE0481A	Diesel	2287	4	<b>582</b>	<b>1229</b>
09/02→	<b>DAILY III PLATFORM/CHASSIS 2.3</b>	F1AE0481B	Diesel	2287	4	<b>583</b>	<b>1229</b>
01/05→	<b>DAILY III PLATFORM/CHASSIS 2.3</b>	F1AE0481M	Diesel	2287	4	<b>588</b>	<b>1232</b>



ccm

X



9



05/99→	DAILY III PLATFORM/CHASSIS 2.8	8140.43B	Diesel	2798	4	720	1335
05/99→	DAILY III PLATFORM/CHASSIS 2.8	8140.43C	Diesel	2798	4	724	1336
05/99→	DAILY III PLATFORM/CHASSIS 2.8	8140.43S	Diesel	2798	4	732	1339
05/99→	DAILY III PLATFORM/CHASSIS 2.8	8140.63.	Diesel	2798	4	734	1343
01/01→	DAILY III PLATFORM/CHASSIS 2.8	8140.43N	Diesel	2798	4	727	1339
11/01→04/06	DAILY III PLATFORM/CHASSIS 2.8	8140.43R	Diesel	2798	4	730	1341
09/04→04/06	DAILY III PLATFORM/CHASSIS 3.0	F1CE0481A	Diesel	2998	4	742	1352
09/04→04/06	DAILY III PLATFORM/CHASSIS 3.0	F1CE0481B	Diesel	2998	4	742	1352
05/06→	DAILY IV BOX BODY / ESTATE 2.3	F1AE0481FA	Diesel	2287	4	586	1232
05/06→	DAILY IV BOX BODY / ESTATE 2.3	F1AE0481GA	Diesel	2287	4	586	1232
05/06→	DAILY IV BOX BODY / ESTATE 2.3	F1AE0481HA	Diesel	2287	4	586	1232
05/06→	DAILY IV BOX BODY / ESTATE 3.0	F1CE0481FA	Diesel	2998	4	743	1352
05/06→	DAILY IV BOX BODY / ESTATE 3.0	F1CE0481HA	Diesel	2998	4	743	1354
05/06→	DAILY IV BOX BODY / ESTATE 3.0	F1CE0481HC	Diesel	2998	4	743	1354
06/06→	DAILY IV BOX BODY / ESTATE 3.0	F1CE0481L	Diesel	2998	4		1353
07/07→	DAILY IV BOX BODY / ESTATE 3.0	F1CE0441A	Gas	2998	4		1351
07/07→	DAILY IV BOX BODY / ESTATE 3.0	F1CE3481LC	Diesel	2998	4	744	
05/06→	DAILY IV BUS 2.3	F1AE0481HA	Diesel	2287	4	586	1232
07/09→	DAILY IV BUS 3.0	F1CE0441A	Gas	2998	4		1351
05/06→	DAILY IV DUMPTRUCK 2.3	F1AE0481FA	Diesel	2287	4	586	1232
05/06→	DAILY IV DUMPTRUCK 2.3	F1AE0481GA	Diesel	2287	4	586	1232
07/07→	DAILY IV DUMPTRUCK 2.3	F1AE0481HA	Diesel	2287	4	586	1232
05/06→	DAILY IV DUMPTRUCK 3.0	F1CE0481FA	Diesel	2998	4	743	1352
05/06→	DAILY IV DUMPTRUCK 3.0	F1CE0481HA	Diesel	2998	4	743	1354
05/06→	DAILY IV DUMPTRUCK 3.0	F1CE0481HC	Diesel	2998	4	743	1354
07/07→	DAILY IV DUMPTRUCK 3.0	F1CE3481LC	Diesel	2998	4	744	
05/06→	DAILY IV PLATFORM/CHASSIS 2.3	F1AE0481FA	Diesel	2287	4	586	1232
05/06→	DAILY IV PLATFORM/CHASSIS 2.3	F1AE0481GA	Diesel	2287	4	586	1232
05/06→	DAILY IV PLATFORM/CHASSIS 2.3	F1AE0481HA	Diesel	2287	4	586	1232
05/06→	DAILY IV PLATFORM/CHASSIS 3.0	F1CE0481FA	Diesel	2998	4	743	1352
05/06→	DAILY IV PLATFORM/CHASSIS 3.0	F1CE0481HA	Diesel	2998	4	743	1354
05/06→	DAILY IV PLATFORM/CHASSIS 3.0	F1CE0481HC	Diesel	2998	4	743	1354
07/07→	DAILY IV PLATFORM/CHASSIS 3.0	F1CE0441A	Gas	2998	4		1351
07/07→	DAILY IV PLATFORM/CHASSIS 3.0	F1CE3481LC	Diesel	2998	4	744	
09/11→	DAILY V BOX BODY / ESTATE 2.3	F1AE3481A	Diesel	2287	4	587	1234
09/11→	DAILY V BOX BODY / ESTATE 2.3	F1AE3481B	Diesel	2287	4	587	1234
09/11→	DAILY V BOX BODY / ESTATE 2.3	F1AE3481C	Diesel	2287	4	587	1234
09/11→	DAILY V DUMPTRUCK 2.3	F1AE3481A	Diesel	2287	4	587	1234
09/11→	DAILY V DUMPTRUCK 2.3	F1AE3481B	Diesel	2287	4	587	1234
09/11→	DAILY V PLATFORM/CHASSIS 2.3	F1AE3481A	Diesel	2287	4	587	1234
09/11→	DAILY V PLATFORM/CHASSIS 2.3	F1AE3481B	Diesel	2287	4	587	1234
	M26 2.5	8140 SC 27.02	Diesel	2500	4	678	1317
	M26 2.8	8140.23.2585	Diesel	2799	4	711	1331
10/08→	MASSIF PICKUP 3.0	F1CE0481FA	Diesel	2998	4	743	1352
10/08→	MASSIF PICKUP 3.0	F1CE0481HA	Diesel	2998	4	743	1354
10/08→	MASSIF SINGLE CAB 3.0	F1CE0481FA	Diesel	2998	4	743	1352
10/08→	MASSIF SINGLE CAB 3.0	F1CE0481HA	Diesel	2998	4	743	1354
10/08→	MASSIF STATION WAGON 3.0	F1CE0481FA	Diesel	2998	4	743	1352
10/08→	MASSIF STATION WAGON 3.0	F1CE0481HA	Diesel	2998	4	743	1354



ccm

x



9



03/81→06/86	<b>A 112 0.9</b>	A112 A.000	Petrol	903	4	<b>16</b>	<b>765</b>
03/81→06/86	<b>A 112 0.9</b>	A112 A5.000	Petrol	903	4	<b>16</b>	<b>766</b>
03/81→06/86	<b>A 112 0.9</b>	A112 B2.000	Petrol	903	4	<b>17</b>	<b>765</b>
03/78→02/84	<b>A 112 1.0</b>	A112 A2.000	Petrol	1050	4	<b>18</b>	<b>767</b>
03/84→12/86	<b>A 112 1.0</b>	A112 B1.000	Petrol	965	4	<b>19</b>	<b>769</b>
08/73→07/76	<b>BETA 1.4</b>	828 A2.000	Petrol	1438	4	<b>145</b>	<b>889</b>
08/73→07/82	<b>BETA 1.6</b>	828 B.000	Petrol	1585	V4	<b>385</b>	<b>1068</b>
08/73→07/76	<b>BETA 1.8</b>	828 A1.000	Petrol	1756	4		<b>1082</b>
04/76→07/82	<b>BETA 2.0</b>	828 B1.000	Petrol	1995	4	<b>385</b>	<b>1068</b>
12/81→12/84	<b>BETA COUPE 1.4</b>	828 D3.000	Petrol	1367	4		<b>852</b>
04/76→12/84	<b>BETA COUPE 1.6</b>	828 B.000	Petrol	1585	V4	<b>385</b>	<b>1068</b>
04/76→12/84	<b>BETA COUPE 2.0</b>	828 B1.000	Petrol	1995	4	<b>385</b>	<b>1068</b>
07/83→12/84	<b>BETA COUPE 2.0</b>	828 B7.000	Petrol	1995	4	<b>446</b>	<b>1078</b>
08/80→09/84	<b>BETA H.P.E. 1.6</b>	828 B.000	Petrol	1585	V4	<b>385</b>	<b>1068</b>
05/76→09/84	<b>BETA H.P.E. 2.0</b>	828 B1.000	Petrol	1995	4	<b>385</b>	<b>1068</b>
05/81→09/84	<b>BETA H.P.E. 2.0</b>	828 B4.000	Petrol	1995	4	<b>445</b>	<b>1127</b>
09/75→05/81	<b>BETA MONTE CARLO 2.0</b>	134 AS.000	Petrol	1995	4	<b>377</b>	<b>1078</b>
05/76→08/82	<b>BETA SPIDER 1.6</b>	828 B.000	Petrol	1585	V4	<b>385</b>	<b>1068</b>
05/76→10/86	<b>BETA SPIDER 2.0</b>	828 B1.000	Petrol	1995	4	<b>385</b>	<b>1068</b>
08/89→03/93	<b>DEDRA 1.6</b>	835 A1.046	Petrol	1581	4	<b>560</b>	<b>1214</b>
08/89→06/94	<b>DEDRA 1.6</b>	835 A1.000	Petrol	1581	4	<b>559</b>	<b>1213</b>
04/93→07/99	<b>DEDRA 1.6</b>	835 C1.000	Petrol	1581	4	<b>561</b>	<b>1214</b>
07/94→07/99	<b>DEDRA 1.6</b>	159 B9.000	Petrol	1581	4	<b>544</b>	<b>1201</b>
01/96→07/99	<b>DEDRA 1.6</b>	182 A4.000	Petrol	1581	4	<b>552</b>	<b>1209</b>
09/89→06/94	<b>DEDRA 1.8</b>	835 A2.000	Petrol	1756	4	<b>401</b>	<b>1083</b>
09/89→07/99	<b>DEDRA 1.8</b>	835 A2.046	Petrol	1756	4	<b>402</b>	<b>1084</b>
08/93→07/99	<b>DEDRA 1.8</b>	835 C5.000	Petrol	1756	4	<b>407</b>	<b>1087</b>
07/94→07/99	<b>DEDRA 1.8</b>	836 A5.000	Petrol	1756	4	<b>408</b>	<b>1084</b>
03/96→07/99	<b>DEDRA 1.8</b>	182 A2.000	Petrol	1747	4	<b>195</b>	<b>929</b>
03/96→07/99	<b>DEDRA 1.8</b>	183 A1.000	Petrol	1747	4	<b>196</b>	<b>930</b>
04/89→07/99	<b>DEDRA 1.9</b>	160 D1.000	Diesel	1929	4	<b>316</b>	<b>1007</b>
04/89→07/99	<b>DEDRA 1.9</b>	835 A4.000	Diesel	1929	4	<b>323</b>	<b>1013</b>
04/89→07/99	<b>DEDRA 1.9</b>	835 A4.046	Diesel	1929	4	<b>324</b>	<b>1013</b>
09/89→07/92	<b>DEDRA 2.0</b>	835 A5.000	Petrol	1995	4	<b>469</b>	<b>1142</b>
09/89→07/99	<b>DEDRA 2.0</b>	835 A5.046	Petrol	1995	4	<b>470</b>	<b>1143</b>
05/90→07/94	<b>DEDRA 2.0</b>	835 A7.000	Petrol	1995	4	<b>471</b>	<b>1129</b>
11/90→06/94	<b>DEDRA 2.0</b>	835 A8.000	Petrol	1995	4	<b>472</b>	<b>1144</b>
11/90→07/94	<b>DEDRA 2.0</b>	835 A7.046	Petrol	1995	4	<b>448</b>	<b>1129</b>
04/91→07/99	<b>DEDRA 2.0</b>	835 A8.046	Petrol	1995	4	<b>473</b>	<b>1145</b>
07/94→07/99	<b>DEDRA 2.0</b>	836 A3.000	Petrol	1995	4	<b>475</b>	<b>1121</b>
10/94→07/99	<b>DEDRA SW 1.6</b>	159 B9.000	Petrol	1581	4	<b>544</b>	<b>1201</b>
01/96→07/99	<b>DEDRA SW 1.6</b>	182 A4.000	Petrol	1581	4	<b>552</b>	<b>1209</b>
07/94→07/99	<b>DEDRA SW 1.8</b>	836 A5.000	Petrol	1756	4	<b>408</b>	<b>1084</b>
03/96→07/99	<b>DEDRA SW 1.8</b>	182 A2.000	Petrol	1747	4	<b>195</b>	<b>929</b>
03/96→07/99	<b>DEDRA SW 1.8</b>	183 A1.000	Petrol	1747	4	<b>196</b>	<b>930</b>
07/94→07/99	<b>DEDRA SW 1.9</b>	160 D1.000	Diesel	1929	4	<b>316</b>	<b>1007</b>
07/94→07/99	<b>DEDRA SW 1.9</b>	835 A4.000	Diesel	1929	4	<b>323</b>	<b>1013</b>
07/94→07/99	<b>DEDRA SW 2.0</b>	836 A3.000	Petrol	1995	4	<b>475</b>	<b>1121</b>
01/86→12/90	<b>DELTA I 1.1</b>	831 B8.000	Petrol	1116	4	<b>129</b>	<b>877</b>
09/79→08/92	<b>DELTA I 1.3</b>	831 A2.000	Petrol	1301	4	<b>523</b>	<b>1187</b>
09/79→08/92	<b>DELTA I 1.3</b>	831 B.000	Petrol	1301	4	<b>524</b>	<b>1187</b>
09/79→12/92	<b>DELTA I 1.5</b>	831 A1.000	Petrol	1498	4	<b>534</b>	<b>1195</b>
09/79→12/92	<b>DELTA I 1.5</b>	831 B1.000	Petrol	1498	4	<b>535</b>	<b>1192</b>
11/82→04/86	<b>DELTA I 1.6</b>	831 A4.000	Petrol	1585	4	<b>386</b>	<b>1069</b>
10/83→12/86	<b>DELTA I 1.6</b>	831 A7.000	Petrol	1585	4	<b>387</b>	<b>1070</b>
08/86→08/88	<b>DELTA I 1.6</b>	831 B3.000	Petrol	1585	4	<b>388</b>	<b>1071</b>
08/86→08/88	<b>DELTA I 1.6</b>	831 B7.000	Petrol	1585	4	<b>390</b>	<b>1066</b>
04/87→03/89	<b>DELTA I 1.6</b>	831 B7.046	Petrol	1585	4	<b>391</b>	<b>1073</b>
05/87→08/92	<b>DELTA I 1.6</b>	149 C2.000	Petrol	1585	4	<b>382</b>	<b>1066</b>
10/86→12/89	<b>DELTA I 1.9</b>	831 D1.000	Diesel	1929	4	<b>321</b>	<b>1011</b>
11/86→08/88	<b>DELTA I 2.0</b>	831 B5.000	Petrol	1995	4	<b>448</b>	<b>1129</b>
12/86→12/92	<b>DELTA I 2.0</b>	831 C5.046	Petrol	1995	4	<b>450</b>	<b>1131</b>
10/87→02/89	<b>DELTA I 2.0</b>	831 C5.000	Petrol	1995	4	<b>449</b>	<b>1130</b>
03/89→09/91	<b>DELTA I 2.0</b>	831 D5.000	Petrol	1995	4	<b>451</b>	<b>1132</b>
06/93→01/94	<b>DELTA I 2.0</b>	831 E5.000	Petrol	1995	4	<b>452</b>	<b>1125</b>
06/93→01/94	<b>DELTA I 2.0</b>	831 E5.046	Petrol	1995	4	<b>452</b>	<b>1125</b>
10/94→08/99	<b>DELTA II 1.4</b>	160 A1.046	Petrol	1372	4	<b>173</b>	<b>913</b>
10/94→08/99	<b>DELTA II 1.4</b>	836 A4.000	Petrol	1372	4	<b>178</b>	<b>915</b>
06/93→08/99	<b>DELTA II 1.6</b>	835 C1.000	Petrol	1581	4	<b>561</b>	<b>1214</b>
01/96→08/99	<b>DELTA II 1.6</b>	182 A4.000	Petrol	1581	4	<b>552</b>	<b>1209</b>
03/96→08/99	<b>DELTA II 1.6</b>	182 A6.000	Petrol	1581	4	<b>552</b>	<b>1209</b>
06/93→08/99	<b>DELTA II 1.8</b>	835 C2.000	Petrol	1756	4	<b>404</b>	<b>1083</b>



ccm X

**9**

07/94→08/99	<b>DELTA II 1.8</b>	835 C4.000	Petrol	1756	4	<b>405</b>	<b>1084</b>
07/94→08/99	<b>DELTA II 1.8</b>	836 A6.000	Petrol	1756	4	<b>410</b>	<b>1090</b>
07/94→08/99	<b>DELTA II 1.8</b>	836 C4.000	Petrol	1756	4	<b>405</b>	<b>1084</b>
03/96→08/99	<b>DELTA II 1.8</b>	182 A2.000	Petrol	1747	4	<b>195</b>	<b>929</b>
03/96→08/99	<b>DELTA II 1.8</b>	183 A1.000	Petrol	1747	4	<b>196</b>	<b>930</b>
10/94→08/99	<b>DELTA II 1.9</b>	160 D1.000	Diesel	1929	4	<b>316</b>	<b>1007</b>
10/94→08/99	<b>DELTA II 1.9</b>	835 A4.000	Diesel	1929	4	<b>323</b>	<b>1013</b>
06/93→08/99	<b>DELTA II 2.0</b>	836 A2.000	Petrol	1995	4	<b>474</b>	<b>1125</b>
06/93→08/99	<b>DELTA II 2.0</b>	836 A3.000	Petrol	1995	4	<b>475</b>	<b>1121</b>
07/96→08/99	<b>DELTA II 2.0</b>	175 A4.000	Petrol	1995	4	<b>444</b>	<b>1126</b>
09/08→	<b>DELTA III 1.4</b>	198 A1.000	Petrol	1368	4	<b>68</b>	<b>816</b>
09/08→	<b>DELTA III 1.4</b>	198 A4.000	Petrol	1368	4	<b>70</b>	<b>816</b>
07/10→	<b>DELTA III 1.4</b>	198 A7.000	Petrol	1368	4	<b>68</b>	<b>816</b>
08/08→	<b>DELTA III 1.6</b>	955 A4.000	Diesel	1598	4	<b>117</b>	<b>869</b>
09/08→	<b>DELTA III 1.6</b>	198 A2.000	Diesel	1598	4	<b>116</b>	<b>864</b>
04/11→	<b>DELTA III 1.6</b>	944 A 3.000	Diesel	1598	4	<b>117</b>	<b>866</b>
01/09→	<b>DELTA III 1.8</b>	939 B1.000	Petrol	1742	4	<b>329</b>	<b>1019</b>
01/09→	<b>DELTA III 1.9</b>	844 A1.000	Diesel	1910	4	<b>234</b>	<b>952</b>
09/08→	<b>DELTA III 2.0</b>	198 A5.000	Diesel	1956	4	<b>341</b>	<b>1030</b>
09/08→	<b>DELTA III 2.0</b>	198 A8.000	Diesel	1956	4	<b>341</b>	<b>1032</b>
09/08→	<b>DELTA III 2.0</b>	844 A2.000	Diesel	1956	4		<b>1034</b>
10/94→10/01	<b>KAPPA 2.0</b>	838 A1.000	Petrol	1998	5	<b>266</b>	<b>966</b>
02/95→10/01	<b>KAPPA 2.0</b>	838 A4.000	Petrol	1995	4	<b>478</b>	<b>1147</b>
07/96→10/01	<b>KAPPA 2.0</b>	838 A6.000	Petrol	1998	5	<b>267</b>	<b>968</b>
06/98→10/01	<b>KAPPA 2.0</b>	175 A3.000	Petrol	1998	5	<b>258</b>	<b>965</b>
08/94→10/01	<b>KAPPA 2.4</b>	838 A2.000	Petrol	2446	5	<b>355</b>	<b>1045</b>
08/94→10/01	<b>KAPPA 2.4</b>	838 A2.027	Petrol	2446	5	<b>355</b>	<b>1045</b>
08/94→10/01	<b>KAPPA 2.4</b>	838 A3.000	Diesel	2387	5	<b>271</b>	<b>974</b>
08/94→10/01	<b>KAPPA 2.4</b>	838 A7.000	Diesel	2387	5	<b>271</b>	<b>974</b>
06/98→10/01	<b>KAPPA 2.4</b>	838 A8.000	Diesel	2387	5	<b>272</b>	<b>975</b>
08/94→10/01	<b>KAPPA 3.0</b>	838 B.000	Petrol	2959	V6	<b>686</b>	<b>1323</b>
07/96→03/01	<b>KAPPA COUPE 2.0</b>	838 A6.000	Petrol	1998	5	<b>267</b>	<b>968</b>
11/96→03/01	<b>KAPPA COUPE 2.0</b>	838 A4.000	Petrol	1995	4	<b>478</b>	<b>1147</b>
06/98→03/01	<b>KAPPA COUPE 2.0</b>	175 A3.000	Petrol	1998	5	<b>258</b>	<b>965</b>
11/96→03/01	<b>KAPPA COUPE 2.4</b>	838 A2.000	Petrol	2446	5	<b>355</b>	<b>1045</b>
11/96→03/01	<b>KAPPA COUPE 3.0</b>	838 B.000	Petrol	2959	V6	<b>686</b>	<b>1323</b>
07/96→10/01	<b>KAPPA SW 2.0</b>	838 A4.000	Petrol	1995	4	<b>478</b>	<b>1147</b>
07/96→10/01	<b>KAPPA SW 2.0</b>	838 A6.000	Petrol	1998	5	<b>267</b>	<b>968</b>
06/98→10/01	<b>KAPPA SW 2.0</b>	175 A3.000	Petrol	1998	5	<b>258</b>	<b>965</b>
07/96→10/01	<b>KAPPA SW 2.4</b>	838 A2.000	Petrol	2446	5	<b>355</b>	<b>1045</b>
07/96→10/01	<b>KAPPA SW 2.4</b>	838 A3.000	Diesel	2387	5	<b>271</b>	<b>974</b>
07/96→10/01	<b>KAPPA SW 2.4</b>	838 A7.000	Diesel	2387	5	<b>271</b>	<b>974</b>
06/98→10/01	<b>KAPPA SW 2.4</b>	838 A8.000	Diesel	2387	5	<b>272</b>	<b>975</b>
07/96→10/01	<b>KAPPA SW 3.0</b>	838 B.000	Petrol	2959	V6	<b>686</b>	<b>1323</b>
07/99→10/05	<b>LYBRA 1.6</b>	182 A4.000	Petrol	1581	4	<b>552</b>	<b>1209</b>
10/00→10/05	<b>LYBRA 1.6</b>	182 B6.000	Petrol	1596	4	<b>180</b>	<b>916</b>
07/99→10/05	<b>LYBRA 1.8</b>	839 A4.000	Petrol	1747	4	<b>200</b>	<b>929</b>
07/99→10/05	<b>LYBRA 1.8</b>	839 A7.000	Petrol	1747	4	<b>201</b>	<b>931</b>
07/99→10/05	<b>LYBRA 1.8</b>	839 A9.000	Petrol	1747	4	<b>202</b>	<b>932</b>
07/99→09/00	<b>LYBRA 1.9</b>	AR 32302	Diesel	1910	4	<b>254</b>	<b>937</b>
09/00→05/01	<b>LYBRA 1.9</b>	AR 37101	Diesel	1910	4	<b>255</b>	<b>964</b>
05/01→10/05	<b>LYBRA 1.9</b>	937 A2.000	Diesel	1910	4	<b>235</b>	<b>953</b>
07/99→09/00	<b>LYBRA 2.0</b>	182 B7.000	Petrol	1998	5	<b>263</b>	<b>966</b>
09/00→10/05	<b>LYBRA 2.0</b>	185 A8.000	Petrol	1998	5	<b>264</b>	<b>970</b>
07/99→02/01	<b>LYBRA 2.4</b>	839 A5.000	Diesel	2387	5	<b>273</b>	<b>973</b>
07/99→02/01	<b>LYBRA 2.4</b>	AR 32501	Diesel	2387	5	<b>273</b>	<b>975</b>
09/00→05/02	<b>LYBRA 2.4</b>	839 A6.000	Diesel	2387	5	<b>275</b>	<b>977</b>
05/02→10/05	<b>LYBRA 2.4</b>	841 C.000	Diesel	2387	5	<b>276</b>	<b>977</b>
07/99→10/05	<b>LYBRA SW 1.6</b>	182 A4.000	Petrol	1581	4	<b>552</b>	<b>1209</b>
10/00→10/05	<b>LYBRA SW 1.6</b>	182 B6.000	Petrol	1596	4	<b>180</b>	<b>916</b>
07/99→10/05	<b>LYBRA SW 1.8</b>	839 A4.000	Petrol	1747	4	<b>200</b>	<b>929</b>
07/99→10/05	<b>LYBRA SW 1.8</b>	839 A7.000	Petrol	1747	4	<b>201</b>	<b>931</b>
07/99→09/00	<b>LYBRA SW 1.9</b>	AR 32302	Diesel	1910	4	<b>254</b>	<b>937</b>
09/00→05/01	<b>LYBRA SW 1.9</b>	AR 37101	Diesel	1910	4	<b>255</b>	<b>964</b>
05/01→10/05	<b>LYBRA SW 1.9</b>	937 A2.000	Diesel	1910	4	<b>235</b>	<b>953</b>
07/99→09/00	<b>LYBRA SW 2.0</b>	182 B7.000	Petrol	1998	5	<b>263</b>	<b>966</b>
09/00→10/05	<b>LYBRA SW 2.0</b>	185 A8.000	Petrol	1998	5	<b>264</b>	<b>970</b>
10/99→09/00	<b>LYBRA SW 2.4</b>	839 A5.000	Diesel	2387	5	<b>273</b>	<b>973</b>
10/99→09/00	<b>LYBRA SW 2.4</b>	AR 32501	Diesel	2387	5	<b>273</b>	<b>975</b>
09/00→10/05	<b>LYBRA SW 2.4</b>	839 A6.000	Diesel	2387	5	<b>275</b>	<b>977</b>
05/02→10/05	<b>LYBRA SW 2.4</b>	841 C.000	Diesel	2387	5	<b>276</b>	<b>977</b>
10/04→	<b>MUSA 1.3</b>	188 A9.000	Diesel	1248	4	<b>22</b>	<b>776</b>



ccm

x



9



09/06→	MUSA 1.3	199 A3.000	Diesel	1248	4	29	778
03/09→	MUSA 1.3	199 B1.000	Diesel	1248	4	30	781
10/04→	MUSA 1.4	843 A 1.000	Petrol	1368	4	77	813
09/05→	MUSA 1.4	350 A1.000	Petrol	1368	4	76	825
10/07→	MUSA 1.4	192 B2.000	Petrol	1368	4	67	813
07/08→	MUSA 1.6	350 A2.000	Diesel	1598	4	116	867
07/08→	MUSA 1.6	350 A3.000	Diesel	1598	4	117	866
10/04→	MUSA 1.9	188 B2.000	Diesel	1910	4	219	944
09/02→11/10	PHEDRA 2.0	RFN (EW10J4)	Petrol	1997	4	486	1156
09/02→11/10	PHEDRA 2.0	RHW (DW10ATED4)	Diesel	1997	4	496	1164
07/03→11/10	PHEDRA 2.0	RHM (DW10ATED4)	Diesel	1997	4	491	1159
06/06→11/10	PHEDRA 2.0	RHK (DW10UTED4)	Diesel	1997	4	483	1159
07/06→11/10	PHEDRA 2.0	RHR (DW10BTED4)	Diesel	1997	4	492	1162
09/02→11/10	PHEDRA 2.2	4HW(DW12ATED4)	Diesel	2179	4	504	1170
04/06→11/10	PHEDRA 2.2	4HP	Diesel	2179	4	501	1153
04/06→11/10	PHEDRA 2.2	4HR	Diesel	2179	4	501	1168
03/08→11/10	PHEDRA 2.2	4HS	Diesel	2179	4	501	1168
03/08→11/10	PHEDRA 2.2	4HT	Diesel	2179	4	503	1168
09/02→11/10	PHEDRA 3.0	ES9 J4S	Petrol	2946	V6	570	1222
01/83→02/92	PRISMA 1.3	831 A2.000	Petrol	1301	4	523	1187
01/83→04/86	PRISMA 1.5	831 A1.000	Petrol	1498	4	534	1195
09/85→02/92	PRISMA 1.5	138 C2.048	Petrol	1498	4	531	1190
09/85→02/92	PRISMA 1.5	831 B1.048	Petrol	1498	4	536	1192
08/86→02/92	PRISMA 1.5	831 B1.000	Petrol	1498	4	535	1192
01/83→04/86	PRISMA 1.6	831 A4.000	Petrol	1585	4	386	1069
05/86→12/89	PRISMA 1.6	831 B7.000	Petrol	1585	4	390	1066
08/86→02/92	PRISMA 1.6	831 B6.000	Petrol	1585	4	389	1072
05/87→12/89	PRISMA 1.6	149 C2.000	Petrol	1585	4	382	1066
01/83→02/92	PRISMA 1.9	831 D.000	Diesel	1911	4	305	1000
05/85→12/89	PRISMA 1.9	831 D1.000	Diesel	1929	4	321	1011
04/86→12/89	PRISMA 2.0	831 B4.000	Petrol	1995	4	447	1128
11/84→12/87	THEMA 2.0	834 C.000	Petrol	1995	4	462	1140
11/84→09/88	THEMA 2.0	834 B.000	Petrol	1995	4	454	1134
03/86→09/88	THEMA 2.0	834 B.048	Petrol	1995	4	456	1135
07/86→05/90	THEMA 2.0	834 C.146	Petrol	1995	4	463	1140
09/87→05/92	THEMA 2.0	834 B.146	Petrol	1995	4	458	1135
05/88→08/92	THEMA 2.0	834 B2.000	Petrol	1995	4	460	1138
09/88→05/92	THEMA 2.0	834 B1.000	Petrol	1995	4	459	1135
12/88→06/90	THEMA 2.0	834 C1.000	Petrol	1995	4	465	1126
02/89→05/92	THEMA 2.0	834 B2.246	Petrol	1995	4	461	1139
04/89→05/92	THEMA 2.0	834 C1.246	Petrol	1995	4	466	1124
08/92→12/93	THEMA 2.0	834 F1.000	Petrol	1995	4	467	1121
10/92→07/94	THEMA 2.0	834 F2.000	Petrol	1995	4	468	1126
11/84→09/88	THEMA 2.4	8144.91	Diesel	2445	4	633	1271
05/88→07/92	THEMA 2.5	8144.97S	Diesel	2500	4	681	1319
06/88→05/92	THEMA 2.5	8144.97	Diesel	2499	4	667	1308
05/92→07/94	THEMA 2.5	8144.97 Y	Diesel	2500	4	683	1319
11/84→09/88	THEMA 2.8	834 E.000	Petrol	2849	6		1244
06/88→05/92	THEMA 2.8	834 E.146	Petrol	2849	V6		1244
08/92→07/94	THEMA 3.0	834 F.000	Petrol	2959	V6	685	1322
12/88→06/90	THEMA SW 2.0	834 C1.000	Petrol	1995	4	465	1126
01/89→03/92	THEMA SW 2.0	834 C.146	Petrol	1995	4	463	1140
02/89→05/92	THEMA SW 2.0	834 B2.246	Petrol	1995	4	461	1139
04/89→03/93	THEMA SW 2.0	834 C1.246	Petrol	1995	4	466	1124
05/89→08/92	THEMA SW 2.0	834 B2.000	Petrol	1995	4	460	1138
05/92→07/94	THEMA SW 2.0	834 F1.000	Petrol	1995	4	467	1121
11/92→07/94	THEMA SW 2.0	834 F2.000	Petrol	1995	4	468	1126
03/87→09/90	THEMA SW 2.4	8144.91	Diesel	2445	4	633	1271
05/88→07/92	THEMA SW 2.5	8144.97S	Diesel	2500	4	681	1319
06/88→05/92	THEMA SW 2.5	8144.97	Diesel	2499	4	667	1308
09/92→07/94	THEMA SW 2.5	8144.97 Y	Diesel	2500	4	683	1319
09/92→07/94	THEMA SW 3.0	834 F.000	Petrol	2959	V6	685	1322
07/02→07/09	THESES 2.0	841 E.000	Petrol	1998	5	268	971
07/02→07/09	THESES 2.4	841 C.000	Diesel	2387	5	276	977
07/02→07/09	THESES 2.4	841 D.000	Petrol	2446	5	357	1043
05/03→07/09	THESES 2.4	841 G.000	Diesel	2387	5	279	979
09/03→07/09	THESES 2.4	841 M.000	Diesel	2387	5	283	982
09/03→07/09	THESES 2.4	841 N.000	Diesel	2387	5	283	983
04/06→07/09	THESES 2.4	841 P.000	Diesel	2387	5	284	985
07/02→07/09	THESES 3.0	841 A.000	Petrol	2959	V6	687	1324
05/80→01/87	TREVI 1.6	828 B.000	Petrol	1585	V4	385	1068
05/80→01/87	TREVI 2.0	828 B4.000	Petrol	1995	4	445	1127





ccm







X















9















08/83→05/85	<b>TREVI 2.0</b>	828 B7.000	Petrol	1995	4	<b>446</b>	<b>1078</b>
11/95→09/03	<b>Y 1.1</b>	176 B2.000	Petrol	1108	4	<b>39</b>	<b>787</b>
03/96→09/03	<b>Y 1.2</b>	188 A4.000	Petrol	1242	4	<b>59</b>	<b>808</b>
03/96→09/03	<b>Y 1.2</b>	840 A3.000	Petrol	1242	4	<b>64</b>	<b>798</b>
04/97→09/03	<b>Y 1.2</b>	176 B9.000	Petrol	1242	4	<b>51</b>	<b>802</b>
10/00→09/03	<b>Y 1.2</b>	188 A5.000	Petrol	1242	4	<b>61</b>	<b>811</b>
03/96→09/03	<b>Y 1.4</b>	840 A4.000	Petrol	1370	4	<b>186</b>	<b>923</b>
10/96→09/03	<b>Y 1.4</b>	840 A2.000	Petrol	1370	4	<b>186</b>	<b>923</b>
03/85→02/89	<b>Y10 1.0</b>	156 A1.000	Petrol	1049	4	<b>91</b>	<b>841</b>
03/85→07/89	<b>Y10 1.0</b>	156 A.000	Petrol	1049	4	<b>99</b>	<b>848</b>
03/85→02/90	<b>Y10 1.0</b>	156 A2.000	Petrol	999	4	<b>35</b>	<b>793</b>
06/85→06/91	<b>Y10 1.0</b>	156 A2.100	Petrol	999	4	<b>35</b>	<b>795</b>
10/87→02/92	<b>Y10 1.0</b>	156 A2.246	Petrol	999	4	<b>35</b>	<b>785</b>
07/89→12/95	<b>Y10 1.1</b>	156 C.046	Petrol	1108	4	<b>35</b>	<b>785</b>
08/89→06/92	<b>Y10 1.1</b>	156 C.000	Petrol	1108	4	<b>35</b>	<b>785</b>
01/95→12/95	<b>Y10 1.1</b>	176 B2.000	Petrol	1108	4	<b>39</b>	<b>787</b>
11/87→12/95	<b>Y10 1.3</b>	156 B.000	Petrol	1301	4	<b>101</b>	<b>849</b>
02/89→12/95	<b>Y10 1.3</b>	146 A 5.046	Petrol	1297	4	<b>93</b>	<b>841</b>
05/11→	<b>YPSILON 0.9</b>	312 A2.000	Petrol	875	2		<b>922</b>
10/03→12/11	<b>YPSILON 1.2</b>	188 A4.000	Petrol	1242	4	<b>59</b>	<b>808</b>
10/03→12/11	<b>YPSILON 1.2</b>	188 A5.000	Petrol	1242	4	<b>61</b>	<b>811</b>
08/10→	<b>YPSILON 1.2</b>	169 A4.000	Petrol	1242	4	<b>46</b>	<b>797</b>
10/03→12/11	<b>YPSILON 1.3</b>	188 A9.000	Diesel	1248	4	<b>22</b>	<b>776</b>
09/06→12/11	<b>YPSILON 1.3</b>	199 A2.000	Diesel	1248	4	<b>26</b>	<b>777</b>
09/06→12/11	<b>YPSILON 1.3</b>	199 A3.000	Diesel	1248	4	<b>29</b>	<b>778</b>
05/11→	<b>YPSILON 1.3</b>	199 B1.000	Diesel	1248	4	<b>30</b>	<b>781</b>
10/03→12/11	<b>YPSILON 1.4</b>	843 A 1.000	Petrol	1368	4	<b>77</b>	<b>813</b>
02/06→12/11	<b>YPSILON 1.4</b>	350 A1.000	Petrol	1368	4	<b>76</b>	<b>825</b>
05/95→09/02	<b>ZETA 2.0</b>	RGX (XU10J2TE)	Petrol	1998	4	<b>515</b>	<b>1180</b>
05/98→07/00	<b>ZETA 2.0</b>	RFV (XU10J4R)	Petrol	1998	4	<b>511</b>	<b>1177</b>
09/99→09/02	<b>ZETA 2.0</b>	RHW (DW10ATED4)	Diesel	1997	4	<b>496</b>	<b>1164</b>
04/00→09/02	<b>ZETA 2.0</b>	RHZ (DW10ATED)	Diesel	1997	4	<b>498</b>	<b>1159</b>
07/00→09/02	<b>ZETA 2.0</b>	RFN	Petrol	1997	4	<b>487</b>	<b>1157</b>
05/96→09/99	<b>ZETA 2.1</b>	P 8 C	Diesel	2088	4	<b>500</b>	<b>1166</b>







		ccm					<b>9</b>
100 G.000	65.00	843	4	Petrol	4		751
100 G.002	65.00	843	4	Petrol	4		752
100 GB.000	65.00	843	4	Petrol	4		753
100 GBC.000	65.00	903	4	Petrol	7		757
100 GBC.040	65.00	903	4	Petrol			757
100 GBS.000	65.00	903	4	Petrol	7		754
100 GC.000	65.00	843	4	Petrol	4		752
100 GF.000	65.00	903	4	Petrol	8		758
100 GL.000	65.00	903	4	Petrol	8		758
100 GL.040	65.00	903	4	Petrol			759
100 GL.048	65.00	903	4	Petrol	9		751
100 GL.064	65.00	903	4	Petrol			754
100 GL3.000	65.00	903	4	Petrol	10		760
100 GL6.000	65.00	843	4	Petrol			754
110 D.000	67.40	499	2	Petrol			771
110 F.000	67.40	499	2	Petrol	21		772
116 (33)	84.00	1962	4	Petrol			1096
1170 A1.000	65.00	899	4	Petrol	5		755
1170 A1.046	65.00	899	4	Petrol	6		756
120.000	67.40	499	2	Petrol	21		772
124 AC.000	80.00	1438	4	Petrol	143		887
124 B2.000	80.00	1438	4	Petrol	144		888
124 B3.000	84.00	1585	4	Petrol	371		1055
124 BL 1.016	80.00	1438	4	Petrol			870
124 BL.016	73.00	1197	4	Petrol			830
125 A.000	80.00	1608	4	Petrol	150		897
125 B.000	80.00	1608	4	Petrol	151		897
126 A.000	73.50	594	2	Petrol	83		831
126 A1.000	77.00	652	2	Petrol	102		850
126 A1.048	77.00	652	2	Petrol	102		850
126 A2.000	80.00	704	2	Petrol	164		904
126 A2.048	80.00	704	2	Petrol	164		904
126 AB.0C.0	73.50	594	2	Petrol			832
126 AB.5C.0	73.50	594	2	Petrol			832
127 A.000	76.00	1049	4	Petrol	88		839
127 A1.000	76.00	1049	4	Petrol	89		840
127 A3.000	76.00	1301	4	Petrol	100		844
127 A5.000	76.00	1302	4	Diesel	95		846
127 A6.000	76.00	1049	4	Petrol	90		840
128 A 064	80.00	1116	4	Petrol			870
128 A.000	80.00	1116	4	Petrol	118		871
128 A.048	80.00	1116	4	Petrol	119		871
128 A1.000	86.00	1290	4	Petrol	506		1172
128 A3.000	86.40	1301	4	Petrol			1183
128 A5.000	86.40	1499	4	Petrol			1190
128 AC.000	86.00	1290	4	Petrol	506		1172
128 AC5.000	80.00	1116	4	Petrol	120		872
128 AR.000	86.00	1290	4	Petrol			1173
128 AS.000	86.00	1290	4	Petrol	507		1173
128 BB.0A0	80.00	1116	4	Petrol			870
131 A.000	76.00	1297	4	Petrol			842
131 A1.000	84.00	1585	4	Petrol	372		1056
131 A6.000	76.00	1297	4	Petrol	92		843
131 AB.1A.0	84.00	1585	4	Petrol			1057
131 AZ.000	80.00	1440	4	Petrol			890
131 B.000	76.00	1297	4	Petrol			843
131 B1.000	84.00	1585	4	Petrol	373		1058
131 B2.000	84.00	1995	4	Petrol	427		1109
131 BZ 0C0	80.00	1440	4	Petrol			890
131 C.000	78.00	1367	4	Petrol	104		852
131 C1.000	78.00	1367	4	Petrol	105		852
131 C2.000	84.00	1585	4	Petrol	374		1059
131 C3.000	84.00	1585	4	Petrol	375		1060
131 C4.000	84.00	1995	4	Petrol	428		1110
131 FZ	80.00	1440	4	Petrol			890
132 A.000	80.00	1592	4	Petrol	146		891
132 A.9000	80.00	1592	4	Petrol	147		892
132 A1.000	84.00	1756	4	Petrol			1075
132 AB.000	84.00	1756	4	Petrol			1075
132 AB.0A.0	80.00	1592	4	Petrol			894
132 AB.1A.0	84.00	1756	4	Petrol			1075
132 AC.000	80.00	1592	4	Petrol	148		895
132 AC1.000	84.00	1756	4	Petrol	394		1076
132 AZ2.000	84.00	1995	4	Petrol	429		1061
132 B.000	84.00	1756	4	Petrol	395		1077
132 B1.000	84.00	1756	4	Petrol			1078
132 B1.000	84.00	1756	4	Petrol	396		1079
132 B2.000	84.00	1995	4	Petrol			1111







		ccm	X 			<b>9</b>	
132 BB 0A 0	80.00	1592	4	Petrol	149		896
132 BB.1A 0	84.00	1756	4	Petrol			1075
132 BB.1A 0	84.00	1756	4	Petrol			1078
132 C.000	84.00	1585	4	Petrol	376		1058
132 C1.000	84.00	1756	4	Petrol	397		1075
132 C2.000	84.00	1995	4	Petrol	430		1112
132 C2.031	84.00	1995	4	Petrol			1111
132 C2.040	84.00	1995	4	Petrol			1111
132 C3.000	84.00	1995	4	Petrol	431		1112
132 C3.031	84.00	1995	4	Petrol	432		1113
132 C3.040	84.00	1995	4	Petrol			1111
132 C6.000	84.00	1585	4	Petrol	377		1061
132 CB.0A.0	84.00	1585	4	Petrol			1061
132 CB.1A	84.00	1756	4	Petrol			1075
132 D.000	84.00	1585	4	Petrol	378		1058
132 D1.000	84.00	1995	4	Petrol	430		1112
132 DB.2A.0	84.00	1995	4	Petrol			1111
132A.B.000-828	80.00	1592	4	Petrol			893
134 A5.000	84.00	1995	4	Petrol	377		1078
138 A.000	86.40	1302	4	Petrol	525		1183
138 A1.000	86.40	1301	4	Petrol	519		1184
138 A2.000	86.40	1498	4	Petrol	527		1191
138 A3.000	86.40	1301	4	Petrol	520		1184
138 A4.000	86.40	1498	4	Petrol	528		1191
138 A5.000	83.00	1714	4	Diesel	327		1016
138 AE 0A.0	80.00	1116	4	Petrol			870
138 AR.000	84.00	1585	4	Petrol	379		1058
138 AR.048	84.00	1585	4	Petrol			1062
138 AR1.000	84.00	1995	4	Petrol	433		1111
138 AR2.000	84.00	1995	4	Petrol	433		1111
138 AS.000	86.40	1499	4	Petrol	537		1192
138 B.000	80.00	1116	4	Petrol	121		871
138 B1.000	80.00	1116	4	Petrol	122		873
138 B2.000	86.40	1302	4	Petrol	526		1188
138 B3.000	86.40	1498	4	Petrol	529		1191
138 B3.048	86.40	1498	4	Petrol	530		1193
138 B5.000	83.00	1714	4	Diesel			1017
138 B6.000	83.00	1714	4	Diesel	328		1018
138 BS.031	86.40	1499	4	Petrol			1190
138 C.000	82.60	1698	4	Diesel	298		993
138 C.048	86.40	1498	4	Petrol			1190
138 C1.000	80.00	1116	4	Petrol	123		873
138 C2.048	86.40	1498	4	Petrol	531		1190
138 C2.048	86.40	1499	4	Petrol	538		1196
138 C3.048	86.40	1498	4	Petrol	532		1194
141 A.000	77.00	652	2	Petrol	103		851
141 A4.000	65.00	769	4	Petrol			748
141 A4.048	65.00	770	4	Petrol			748
141 B.000	65.00	769	4	Petrol	1		749
141 C2.000	70.00	999	4	Petrol	41		790
146 A 5.046	76.00	1297	4	Petrol	93		841
146 A.000	65.00	903	4	Petrol	11		761
146 A.048	65.00	903	4	Petrol	12		751
146 A1.000	65.00	903	4	Petrol	13		762
146 A2.000	80.50	1301	4	Petrol	166		907
146 A2.146	80.50	1301	4	Petrol	167		908
146 A2.166	76.00	994	4	Petrol	97		847
146 A2.246	80.50	1301	4	Petrol	167		907
146 A4.000	80.00	1116	4	Petrol			870
146 A4.044	80.00	1116	4	Petrol			873
146 A4.048	80.00	1116	4	Petrol	124		873
146 A5.000	86.40	1301	4	Petrol	521		1185
146 A6.000	80.00	1116	4	Petrol	126		874
146 A8.000	80.50	1372	4	Petrol	168		909
146 A8.046	80.50	1372	4	Petrol	169		909
146 A9.000	80.00	1116	4	Petrol	127		875
146 B.000	78.00	1367	4	Diesel	106		853
146 B1.000	76.00	1301	4	Diesel	94		845
146 B2.000	82.60	1698	4	Diesel	299		994
146 B3.000	78.00	1367	4	Diesel	106		853
146 B4.000	70.00	999	4	Petrol	42		791
146 C1.000	80.50	1372	4	Petrol	170		910
146 C3.000	80.00	1116	4	Petrol	128		876
146 C5.000	80.50	1372	4	Petrol	171		910
146 C6.000	86.40	1581	4	Petrol	540		1198
146 D5.000	80.50	1372	4	Petrol	171		910
146 D6.000	86.40	1581	4	Petrol	540		1198
146 D7.000	82.60	1698	4	Diesel	300		996

		ccm	X 			<b>9</b>	
146 E1.011	70.00	999	4	Petrol	34	792	
149 A.000	84.00	1585	4	Petrol		1063	
149 A1.000	82.60	1929	4	Diesel	306	1001	
149 A2.000	84.00	1585	4	Petrol	380	1064	
149 A3.000	86.40	1301	4	Petrol	522	1186	
149 A4.000	84.00	1585	4	Petrol	381	1065	
149 A5.000	86.40	1498	4	Petrol	533	1194	
149 A5.046	86.40	1498	4	Petrol		1190	
149 A7.000	86.40	1302	4	Petrol	526	1188	
149 A7.003	86.40	1301	4	Petrol		1183	
149 A7.046	86.40	1302	4	Petrol		1189	
149 B1.000	82.60	1929	4	Diesel	307	1001	
149 B2.000	82.60	1697	4	Diesel	295	995	
149 B3.000	82.60	1698	4	Diesel	301	994	
149 B4.000	82.60	1697	4	Diesel	296	994	
149 B4.046	82.60	1697	4	Diesel	297	993	
149 B5.046	82.60	1929	4	Diesel	308	1002	
149 C1.000	86.40	1499	4	Petrol	539	1197	
149 C2.000	84.00	1585	4	Petrol	382	1066	
149 C2.000	84.00	1595	4	Petrol		1063	
149 C2.046	84.00	1595	4	Petrol	392	1063	
149 C3.000	84.00	1585	4	Petrol	383	1063	
154 A.048	84.00	1585	4	Petrol	384	1067	
154 A1.000	84.00	1995	4	Petrol	434	1114	
154 A2.000	84.00	1995	4	Petrol	435	1115	
154 B.000	82.60	1929	4	Diesel	309	1003	
154 C3.000	84.00	1995	4	Petrol	436	1116	
154 C3.046	84.00	1995	4	Petrol	437	1117	
154 C4.000	84.00	1995	4	Petrol		1118	
154 C4.046	84.00	1995	4	Petrol	438	1119	
154 C5.000	84.00	1995	4	Petrol		1120	
154 C6.000	82.60	1929	4	Diesel	310	1004	
154 D1.000	82.60	1929	4	Diesel	310	1005	
154 E1.000	84.00	1995	4	Petrol	439	1121	
156 A.000	76.10	1049	4	Petrol	98	848	
156 A.000	76.10	1049	4	Petrol	99	848	
156 A1.000	76.00	1049	4	Petrol	91	841	
156 A2.000	70.00	999	4	Petrol	35	793	
156 A2.000	70.00	999	4	Petrol	43	793	
156 A2.0157	70.00	999	4	Petrol		794	
156 A2.048	70.00	999	4	Petrol	36	790	
156 A2.048	70.00	999	4	Petrol	44	790	
156 A2.050	70.00	999	4	Petrol		794	
156 A2.100	70.00	999	4	Petrol	35	795	
156 A2.100	70.00	999	4	Petrol	36	793	
156 A2.146	70.00	999	4	Petrol	44	790	
156 A2.246	70.00	999	4	Petrol	35	785	
156 A2.246	70.00	999	4	Petrol	36	785	
156 A2.256	70.00	999	4	Petrol		791	
156 A3.000	70.00	999	4	Petrol	37	793	
156 A3.100	70.00	999	4	Petrol	36	790	
156 A4.000	65.00	770	4	Petrol	2	750	
156 A4.048	65.00	770	4	Petrol	3	750	
156 A5.000	76.00	1302	4	Diesel	96	845	
156 B.000	76.10	1301	4	Petrol	101	849	
156 C.000	70.00	1108	4	Petrol	35	785	
156 C.046	70.00	1108	4	Petrol	35	785	
156 C.046	70.00	1108	4	Petrol	37	785	
159 A2.000	80.50	1372	4	Petrol	172	911	
159 A3.000	86.40	1581	4	Petrol	541	1199	
159 A3.046	86.40	1581	4	Petrol	542	1199	
159 A3.048	86.40	1581	4	Petrol	543	1200	
159 A4.000	84.00	1756	4	Petrol	398	1080	
159 A4.046	84.00	1756	4	Petrol	399	1080	
159 A5.046	84.00	1995	4	Petrol	440	1122	
159 A6.046	84.00	1995	4	Petrol	441	1123	
159 B9.000	86.40	1581	4	Petrol	544	1201	
159 B9.000	86.40	1581	4	Petrol	545	1202	
160 A1.000	80.50	1372	4	Petrol	172	911	
160 A1.046	80.50	1372	4	Petrol	173	912	
160 A1.046	80.50	1372	4	Petrol	173	913	
160 A1.048	80.50	1372	4	Petrol	174	912	
160 A2.000	86.40	1581	4	Petrol	546	1203	
160 A3.000	70.00	1108	4	Petrol	37	786	
160 A5.000	84.00	1756	4	Petrol	400	1081	
160 A6.000	82.60	1929	4	Diesel	311	1006	
160 A6.046	82.60	1929	4	Diesel	312	1006	
160 A7.000	82.60	1929	4	Diesel	313	1001	







		ccm	X				<b>9</b>	
160 A8.046	84.00	1995	4	Petrol	442	1124		
160 B6.046	82.60	1929	4	Diesel	314	1006		
160 D1.000	82.60	1929	4	Diesel	315	1006		
160 D1.000	82.60	1929	4	Diesel	316	1007		
160 D100	82.60	1929	4	Diesel	317	1008		
169 A1.000	69.60	1248	4	Diesel	22	773		
169 A3.000	72.00	1368	4	Petrol	65	813		
169 A4.000	70.80	1242	4	Petrol	45	797		
169 A4.000	70.80	1242	4	Petrol	46	797		
169 A5.000	69.60	1248	4	Diesel	23	774		
169 A5.000	69.60	1248	4	Diesel	24	775		
169 B	84.00	1796	4	Petrol	413	1094		
170 A.000	80.00	704	2	Petrol	165	905		
170 A.046	80.00	704	2	Petrol	165	906		
170 A1.000	65.00	903	4	Petrol	14	763		
170 A1.046	65.00	903	4	Petrol	15	763		
170 B	88.00	1971	4	Petrol	574	1224		
170 D	88.00	1971	4	Petrol	575	1224		
175 A1.000	84.00	1995	4	Petrol	443	1125		
175 A3.000	82.00	1998	5	Petrol	258	965		
175 A3.000	82.00	1998	5	Petrol	259	965		
175 A4.000	84.00	1995	4	Petrol	444	1126		
176 A3.000	82.60	1698	4	Diesel	302	997		
176 A4.000	80.50	1372	4	Petrol	175	914		
176 A5.000	82.60	1698	4	Diesel	303	998		
176 A6.000	70.00	1108	4	Petrol	36	787		
176 A7.000	70.80	1242	4	Petrol	47	798		
176 A8.000	70.80	1242	4	Petrol	48	799		
176 A9.000	86.40	1581	4	Petrol	547	1204		
176 B1.000	70.80	1242	4	Petrol	49	800		
176 B2.000	70.00	1108	4	Petrol	38	787		
176 B2.000	70.00	1108	4	Petrol	39	787		
176 B3.000	82.60	1698	4	Diesel	304	994		
176 B4.000	70.80	1242	4	Petrol	50	799		
176 B6.000	80.50	1372	4	Petrol	175	914		
176 B7.000	82.60	1698	4	Diesel	302	998		
176 B9.000	70.80	1242	4	Petrol	51	802		
176 B9.000	70.80	1242	4	Petrol	52	801		
178 B2.000	80.50	1372	4	Petrol	176	910		
178 B2.016	80.50	1372	4	Petrol	177	910		
178 B3.000	86.40	1581	4	Petrol	548	1205		
178 B5.000	70.80	1242	4	Petrol	53	803		
178 B7.045	70.80	1242	4	Petrol	54	804		
178 B9.033	70.00	1108	4	Petrol	34	788		
178 C4.066	70.80	1242	4	Petrol	55	804		
178 C7.098	86.40	1581	4	Petrol	549	1206		
178 C9.066	82.60	1698	4	Diesel		999		
178 D2.011	86.40	1581	4	Petrol	550	1207		
178 D9.011	70.00	999	4	Petrol	34			
178 E2.000	70.80	1242	4	Petrol	56	805		
178 E5.022	75.40	1461	4	Petrol	87			
178 E7.000	80.50	1596	4	Petrol	179			
178 E8.011	70.80	1242	4	Petrol		806		
178 E9.011	70.80	1242	4	Petrol		806		
178 F3.011	72.00	1368	4	Petrol		814		
182 A1.000	82.00	1998	5	Petrol	260	966		
182 A2.000	82.00	1747	4	Petrol	194	929		
182 A2.000	82.00	1747	4	Petrol	195	929		
182 A3.000	82.00	1370	4	Petrol	184	923		
182 A4.000	86.40	1581	4	Petrol	551	1208		
182 A4.000	86.40	1581	4	Petrol	552	1209		
182 A5.000	82.00	1370	4	Petrol	185	923		
182 A6.000	86.40	1581	4	Petrol	552	1209		
182 A6.000	86.40	1581	4	Petrol	553	1210		
182 A7.000	82.00	1910	4	Diesel	208	936		
182 A8.000	82.00	1910	4	Diesel	209	936		
182 B2.000	70.80	1242	4	Petrol	57	807		
182 B3.000	82.00	1998	5	Petrol	261	967		
182 B4.000	82.00	1910	4	Diesel	210	937		
182 B5.098	86.40	1581	4	Petrol	554	1206		
182 B6.000	80.50	1596	4	Petrol	180	916		
182 B6.000	80.50	1596	4	Petrol	181	916		
182 B7.000	82.00	1998	5	Petrol	262	968		
182 B7.000	82.00	1998	5	Petrol	263	966		
182 B9.000 Euro 3 (D3)	82.00	1910	4	Diesel	211	939		
182 B9.000 Euro 3 (D3)	82.00	1910	4	Diesel	212	938		
183 A1.000	82.00	1747	4	Petrol	196	930		
183 A1.000	82.00	1747	4	Petrol	197	929		







		ccm				
					<b>9</b>	
185 A2.000	82.00	2387	5	Diesel	269	972
185 A3.000 Euro 3 (D3)	86.40	1581	4	Petrol	555	1208
185 A4.011	82.00	1998	5	Petrol		969
185 A6.000	82.00	2387	5	Diesel	270	973
185 A7.011	83.00	2446	5	Petrol		1043
185 A8.000	82.00	1998	5	Petrol	264	970
185 A8.000 Euro 3 (D3)	82.00	1998	5	Petrol	265	970
185 B4.000	82.00	1910	4	Diesel		940
186 A3.000	86.40	1581	4	LPG	556	1211
186 A4.000	86.40	1581	4	Petrol	557	1212
186 A6.000	82.00	1910	4	Diesel	213	941
186 A8.000	82.00	1910	4	Diesel	214	939
186 A9.000	82.00	1910	4	Diesel	215	942
187 A1.000	70.00	1108	4	Petrol	40	789
188 A2.000	82.00	1910	4	Diesel	216	941
188 A3.000	82.00	1910	4	Diesel	217	943
188 A4.000	70.80	1242	4	Petrol	58	809
188 A4.000	70.80	1242	4	Petrol	59	808
188 A5.000	70.80	1242	4	Petrol	60	810
188 A5.000 Euro 3 (D3)	70.80	1242	4	Petrol	61	811
188 A6.000	82.00	1747	4	Petrol	198	931
188 A7.000	82.00	1910	4	Diesel	218	941
188 A8.000	69.60	1248	4	Diesel	25	776
188 A9.000	69.60	1248	4	Diesel	22	776
188 B2.000	82.00	1910	4	Diesel	219	944
188 B2.000	82.00	1910	4	Diesel	220	942
192 A1.000	82.00	1910	4	Diesel	221	945
192 A2.000	83.00	2446	5	Petrol	354	1044
192 A3.000	82.00	1910	4	Diesel	222	941
192 A4.000	82.00	1747	4	Petrol	199	931
192 A5.000	82.00	1910	4	Diesel	223	946
192 A5.000 Euro 3 (D3)	82.00	1910	4	Diesel	224	946
192 A7.011	83.00	2446	5	Petrol		1043
192 A8.000	82.00	1910	4	Diesel	225	947
192 A9.000	82.00	1910	4	Diesel	226	948
192 B1.000	82.00	1910	4	Diesel	223	946
192 B1.000	82.00	1910	4	Diesel	224	946
192 B2.000	72.00	1368	4	Petrol	66	813
192 B2.000	72.00	1368	4	Petrol	67	813
192 B3.000	79.00	1598	4	Petrol	114	862
192 B4.000	82.00	1910	4	Diesel	227	949
192 B5.000	82.00	1910	4	Diesel	228	948
194 A1.000	86.00	2198	4	Petrol	517	1174
198 A1.000	72.00	1368	4	Petrol	68	815
198 A1.000	72.00	1368	4	Petrol	68	816
198 A1.000	72.00	1368	4	Petrol	69	815
198 A2.000	79.50	1598	4	Diesel	116	864
198 A3.000	79.50	1598	4	Diesel	116	865
198 A4.000	72.00	1368	4	Petrol	68	815
198 A4.000	72.00	1368	4	Petrol	69	815
198 A4.000	72.00	1368	4	Petrol	70	816
198 A5.000	83.00	1956	4	Diesel	340	1031
198 A5.000	83.00	1956	4	Diesel	341	1030
198 A6.000	79.50	1598	4	Diesel	117	866
198 A7.000	72.00	1368	4	Petrol	68	815
198 A7.000	72.00	1368	4	Petrol	68	816
198 A8.000	83.00	1956	4	Diesel	341	1032
198 A9.000	83.00	1956	4	Diesel		1033
199 A1.000	72.00	1368	4	Petrol		817
199 A1.000	72.00	1368	4	Petrol	71	817
199 A2.000	69.60	1248	4	Diesel	22	777
199 A2.000	69.60	1248	4	Diesel	26	777
199 A3.000	69.60	1248	4	Diesel	27	779
199 A3.000	69.60	1248	4	Diesel	28	778
199 A3.000	69.60	1248	4	Diesel	29	778
199 A4.000 Euro 4 (D4)	70.80	1242	4	Petrol	62	797
199 A5.000	82.00	1910	4	Diesel	229	950
199 A6.000	72.00	1368	4	Petrol	72	818
199 A6.000	72.00	1368	4	Petrol	73	818
199 A7.000	72.00	1368	4	Petrol	74	819
199 A8.000	72.00	1368	4	Petrol	68	815
199 A8.000	72.00	1368	4	Petrol	70	815
199 A9.000 Euro 5	69.60	1248	4	Diesel	30	780
199 B1.000 Euro 5	69.60	1248	4	Diesel	30	780
199 B1.000 Euro 5	69.60	1248	4	Diesel	30	781
199 B2.000 Euro 5	69.60	1248	4	Diesel	25	780
199 B4.000 Euro 5	69.60	1248	4	Diesel	31	782
199 B4.000 Euro5/Euro6	69.60	1248	4	Diesel	32	782







		ccm	X 			<b>9</b>	
199 B5.000 Euro 5	79.50	1598	4	Diesel	117		
199 B6.000 Euro 6	80.50	875	2	Petrol			920
213 H	95.00	4678	6	Diesel			1349
213.000	95.00	4678	6	Diesel			1349
220 A 2.000	86.40	1581	4	Petrol	558		1204
223 A3.011	70.80	1242	4	Petrol			812
223 A5.000	70.80	1242	4	Petrol	63		805
223 A6.000 Euro 3 (D3)	82.00	1910	4	Diesel	230		951
223 A7.000	82.00	1910	4	Diesel	231		942
223 A9.000	69.60	1248	4	Diesel	33		783
223 B1.000	82.00	1910	4	Diesel	232		938
223 B2.000	82.00	1910	4	Diesel	233		938
230 A.000	95.00	2693	4	Diesel			1349
230 A2.000	82.60	1929	4	Diesel	318		1009
230 A3.000	82.60	1929	4	Diesel	319		1010
230 A4.000 Euro 2	82.60	1929	4	Diesel	319		1010
250 A1.000 Euro 5	83.00	1956	4	Diesel	340		1032
263 A1.000 Euro 5	83.00	1956	4	Diesel	341		1032
263 A2.000	69.60	1248	4	Diesel	32		784
263 A3.000	79.50	1598	4	Diesel	116		866
263 A4.000	79.50	1598	4	Diesel	117		866
280 A1.000	82.60	1929	4	Diesel	320		1010
310 A1.011	70.00	999	4	Petrol			796
310 A2.011	72.00	1368	4	Petrol			820
312 A1.000	72.00	1368	4	Petrol	75		821
312 A2.000 Euro 5	80.50	875	2	Petrol			921
312 A2.000 Euro 5	80.50	875	2	Petrol			922
312 A3.000	72.00	1368	4	Petrol	68		822
323 B6.600	72.00	1368	4	Petrol			823
327 A.011	72.00	1368	4	Petrol			824
350 A1.000	72.00	1368	4	Petrol	76		825
350 A1.000 Euro4/Euro5	72.00	1368	4	Petrol	74		825
350 A1.000 Euro4/Euro5	72.00	1368	4	Petrol	76		825
350 A2.000	79.50	1598	4	Diesel	116		867
350 A2.000	79.50	1598	4	Diesel	117		867
350 A3.000	79.50	1598	4	Diesel	117		
350 A3.000	79.50	1598	4	Diesel	117		866
4.108	79.375	1760	4	Diesel	115		863
4HP	85.00	2179	4	Diesel	501		1153
4HR	85.00	2179	4	Diesel	501		1168
4HS Euro 4 (D4)	85.00	2179	4	Diesel	501		1168
4HT (DW12BTED4) Euro 4 (D4)	85.00	2179	4	Diesel	502		1168
4HT Euro 4 (D4)	85.00	2179	4	Diesel	503		1168
4HU Euro 4 (D4)	86.00	2198	4	Diesel			1181
4HV Euro 4 (D4)	86.00	2198	4	Diesel	516		1182
4HW (DW12ATED4)	85.00	2179	4	Diesel	505		1169
4HW(DW12ATED4)	85.00	2179	4	Diesel	504		1170
4HX (DW12TED4)	85.00	2179	4	Diesel			1171
605 D	82.00	1901	4	Diesel			935
6132 AZ 2.000	84.00	1995	4	Petrol	479		1148
8025.01	95.00	1559	2	Diesel	738		1346
803 A.062 (8030.01)	95.00	2339	3	Diesel	739		1346
8030.00	95.00	2340	3	Diesel	740		1348
8035.01	95.00	2338	3	Diesel			1347
8040.00	95.00	3120	4	Diesel	741		1350
804A (8040.01)	95.00	3119	4	Diesel	739		1346
806 A (8060.01/.11)	95.00	4678	6	Diesel			1346
8140 SC 27.02	93.00	2500	4	Diesel	678		1317
8140.07	93.00	2499	4	Diesel			1274
8140.07.2585 Euro 1	93.00	2500	4	Diesel	671		1310
8140.07.2700	93.00	2499	4	Diesel	635		1275
8140.07.2701	93.00	2499	4	Diesel	636		1276
8140.07.2710	93.00	2499	4	Diesel	613		1277
8140.07.2711	93.00	2499	4	Diesel	613		1277
8140.07.2712	93.00	2499	4	Diesel	637		1278
8140.07.2713	93.00	2499	4	Diesel			1277
8140.07.3700 Euro 1	93.00	2499	4	Diesel			1279
8140.07.3710 Euro 1	93.00	2499	4	Diesel	638		1280
8140.07.3711 Euro 1	93.00	2499	4	Diesel	613		1277
8140.07.3712 Euro 1	93.00	2499	4	Diesel	613		1277
8140.07.3713 Euro 1	93.00	2499	4	Diesel	613		1277
8140.21	93.00	2445	4	Diesel	613		1251
8140.21.200	93.00	2445	4	Diesel	614		1252
8140.21.200 D.I.	93.00	2445	4	Diesel	615		1253
8140.21.201	93.00	2445	4	Diesel	613		1254
8140.21.201-203	93.00	2445	4	Diesel			1251
8140.21.202	93.00	2445	4	Diesel	613		1254
8140.21.203	93.00	2445	4	Diesel	613		1254







		ccm	X 			<b>9</b>	
8140.21.212	93.00	2445	4	Diesel	613		1254
8140.21.212, 8140.21.290	93.00	2445	4	Diesel	613		
8140.21.214	93.00	2445	4	Diesel	616		1255
8140.21.290	93.00	2445	4	Diesel	613		1254
8140.23.	94.40	2798	4	Diesel	710		1329
8140.23.2200	94.40	2800	4	Diesel			1330
8140.23.2585 Euro 2	94.40	2799	4	Diesel	711		1331
8140.23.3700 Euro 2	94.40	2798	4	Diesel	711		1331
8140.23.3701 Euro 2	94.40	2798	4	Diesel	712		1332
8140.23.3710 Euro 2	94.40	2798	4	Diesel	712		1332
8140.23.3711 Euro 2	94.40	2798	4	Diesel	712		1332
8140.23.3713 Euro 2	94.40	2798	4	Diesel	712		1332
8140.23.3720 Euro 2	94.40	2798	4	Diesel	712		1332
8140.23.3721 Euro 2	94.40	2798	4	Diesel	712		1332
8140.23.3730 Euro 2	94.40	2798	4	Diesel	712		1332
8140.23.3731 Euro 2	94.40	2798	4	Diesel	712		1332
8140.23.3750 Euro 2	94.40	2798	4	Diesel	712		1332
8140.23.3751 Euro 2	94.40	2798	4	Diesel	712		1332
8140.23.3760 Euro 2	94.40	2798	4	Diesel	713		1332
8140.23.3801 Euro 2	94.40	2798	4	Diesel	714		1332
8140.23.3811 Euro 2	94.40	2798	4	Diesel	714		1332
8140.23.3821 Euro 2	94.40	2798	4	Diesel	714		1332
8140.27	93.00	2500	4	Diesel	672		1311
8140.27 S	93.00	2445	4	Diesel	617		1258
8140.27.210, 8140.27.213	93.00	2445	4	Diesel	613		1256
8140.27.2100	93.00	2500	4	Diesel	673		1312
8140.27.215	93.00	2499	4	Diesel	639		1277
8140.27.218	93.00	2445	4	Diesel	613		1257
8140.27.218	93.00	2499	4	Diesel	639		1281
8140.27.2582	93.00	2499	4	Diesel	640		1282
8140.27.2700	93.00	2499	4	Diesel	641		1283
8140.27.2720	93.00	2499	4	Diesel	641		1284
8140.27.2811	93.00	2499	4	Diesel	642		1285
8140.27R.2700	93.00	2499	4	Diesel	643		1286
8140.27R.2700, 8140.27S.2700, 8140.27.2700, 8140.27R, 8140.27S	93.00	2499	4	Diesel	644		1257
8140.27R.2780	93.00	2499	4	Diesel			1277
8140.27R.2782	93.00	2499	4	Diesel	645		1287
8140.27R.2786	93.00	2499	4	Diesel	646		1277
8140.27R.2787	93.00	2499	4	Diesel			1277
8140.27S.2700	93.00	2499	4	Diesel	647		1288
8140.27S.2701	93.00	2499	4	Diesel	639		1277
8140.27S.2710	93.00	2499	4	Diesel	639		1277
8140.27S.2711	93.00	2499	4	Diesel	639		1277
8140.27S.2720	93.00	2499	4	Diesel	639		1277
8140.27S.2721	93.00	2499	4	Diesel	639		1277
8140.27S.2730	93.00	2499	4	Diesel	639		1277
8140.27S.2731	93.00	2499	4	Diesel	639		1277
8140.27S.2750	93.00	2499	4	Diesel	639		1277
8140.27S.2751	93.00	2499	4	Diesel			1277
8140.27S.2760	93.00	2499	4	Diesel	648		1277
8140.27S.2761	93.00	2499	4	Diesel	649		1277
8140.27S.2770	93.00	2499	4	Diesel	639		1277
8140.27S.2771	93.00	2499	4	Diesel	639		1277
8140.27S.2801	93.00	2499	4	Diesel	650		1289
8140.27S.2811	93.00	2499	4	Diesel	639		1277
8140.27S.2811, 8140.27S.3811	93.00	2499	4	Diesel	613		
8140.27S.2885	93.00	2499	4	Diesel	651		1286
8140.27S.3700	93.00	2499	4	Diesel			1277
8140.27S.3700 Euro 1	93.00	2499	4	Diesel			1290
8140.27S.3701	93.00	2499	4	Diesel	639		1277
8140.27S.3711	93.00	2499	4	Diesel	639		1277
8140.27S.3720	93.00	2499	4	Diesel	639		1277
8140.27S.3721	93.00	2499	4	Diesel	639		1277
8140.27S.3750	93.00	2499	4	Diesel	639		1277
8140.27S.3751	93.00	2499	4	Diesel	639		1277
8140.27S.3760	93.00	2499	4	Diesel	639		1277
8140.27S.3761	93.00	2499	4	Diesel	639		1277
8140.27S.3770	93.00	2499	4	Diesel	648		1277
8140.27S.3771	93.00	2499	4	Diesel	639		1277
8140.27S.3780	93.00	2499	4	Diesel	639		1277
8140.27S.3781	93.00	2499	4	Diesel			1277
8140.27S.3811	93.00	2499	4	Diesel	649		1277
8140.43	94.40	2800	4	Diesel	736		1344
8140.43. Euro 2	94.40	2798	4	Diesel	717		1333
8140.43.2585 Euro 2	94.40	2798	4	Diesel	715		1329
8140.43.3700 Euro 2	94.40	2798	4	Diesel	715		1329
8140.43.3711 Euro 2	94.40	2798	4	Diesel			1332















		ccm	X 			<b>9</b>	
8140.43.3713 Euro 2	94.40	2798	4	Diesel			1332
8140.43.3718 Euro 2	94.40	2798	4	Diesel			1332
8140.43.3721 Euro 2	94.40	2798	4	Diesel			1332
8140.43.3723 Euro 2	94.40	2798	4	Diesel			1332
8140.43.3728 Euro 2	94.40	2798	4	Diesel	716		1332
8140.43.3731 Euro 2	94.40	2798	4	Diesel			1332
8140.43.3900 Euro 2	94.40	2798	4	Diesel	715		1329
8140.43.3911 Euro 2	94.40	2798	4	Diesel			1332
8140.43.3921 Euro 2	94.40	2798	4	Diesel			1332
8140.43.3931 Euro 2	94.40	2798	4	Diesel			1332
8140.43.K	94.40	2798	4	Diesel			1332
8140.43B Euro 3 (D3)	94.40	2798	4	Diesel	720		1335
8140.43B.4300 Euro 3 (D3)	94.40	2798	4	Diesel	718		1334
8140.43B.4305 Euro 3 (D3)	94.40	2798	4	Diesel	718		1334
8140.43B.4320 Euro 3 (D3)	94.40	2798	4	Diesel	719		1334
8140.43B.4325 Euro 3 (D3)	94.40	2798	4	Diesel	718		1334
8140.43B.4330 Euro 3 (D3)	94.40	2798	4	Diesel	718		1334
8140.43B.4335 Euro 3 (D3)	94.40	2798	4	Diesel	718		1334
8140.43C Euro 2	94.40	2798	4	Diesel	724		1336
8140.43C.4000 Euro 3 (D3)	94.40	2798	4	Diesel	718		1332
8140.43C.4005 Euro 3 (D3)	94.40	2798	4	Diesel	718		1332
8140.43C.4020 Euro 3 (D3)	94.40	2798	4	Diesel	721		1332
8140.43C.4021 Euro 3 (D3)	94.40	2798	4	Diesel	721		1332
8140.43C.4025 Euro 3 (D3)	94.40	2798	4	Diesel	718		1332
8140.43C.4026 Euro 3 (D3)	94.40	2798	4	Diesel	718		1332
8140.43C.4030 Euro 3 (D3)	94.40	2798	4	Diesel	722		1332
8140.43C.4031 Euro 3 (D3)	94.40	2798	4	Diesel	722		1332
8140.43C.4035 Euro 3 (D3)	94.40	2798	4	Diesel	723		1332
8140.43C.4036 Euro 3 (D3)	94.40	2798	4	Diesel	719		1332
8140.43K.4000 Euro 3 (D3)	94.40	2798	4	Diesel	725		1337
8140.43K.4020 Euro 3 (D3)	94.40	2798	4	Diesel	718		1332
8140.43K.4030 Euro 3 (D3)	94.40	2798	4	Diesel			1332
8140.43N Euro 3 (D3)	94.40	2798	4	Diesel	726		1340
8140.43N Euro 3 (D3)	94.40	2798	4	Diesel	727		1339
8140.43N.4300 Euro 3 (D3)	94.40	2798	4	Diesel	712		1338
8140.43N.4320 Euro 3 (D3)	94.40	2798	4	Diesel	712		1338
8140.43N.4330 Euro 3 (D3)	94.40	2798	4	Diesel	712		1338
8140.43N.4400 Euro 3 (D3)	94.40	2798	4	Diesel	712		1338
8140.43N.4430 Euro 3 (D3)	94.40	2798	4	Diesel	712		1338
8140.43P Euro 3 (D3)	94.40	2798	4	Diesel	728		1330
8140.43R Euro 3 (D3)	94.40	2798	4	Diesel	730		1341
8140.43R.4300 Euro 3 (D3)	94.40	2798	4	Diesel	712		1332
8140.43R.4320 Euro 3 (D3)	94.40	2798	4	Diesel	712		1332
8140.43R.4330 Euro 3 (D3)	94.40	2798	4	Diesel	712		1332
8140.43R.4400 Euro 3 (D3)	94.40	2798	4	Diesel	712		1332
8140.43R.4420 Euro 3 (D3)	94.40	2798	4	Diesel	712		1332
8140.43R.4430 Euro 3 (D3)	94.40	2798	4	Diesel	729		1332
8140.43S	94.40	2798	4	Diesel	731		1342
8140.43S Euro 3 (D3)	94.40	2798	4	Diesel	732		1339
8140.43S.4000 Euro 3 (D3)	94.40	2798	4	Diesel	712		1338
8140.43S.4020 Euro 3 (D3)	94.40	2798	4	Diesel	712		1338
8140.43S.4030 Euro 3 (D3)	94.40	2798	4	Diesel	712		1338
8140.43S.4140 Euro 3 (D3)	94.40	2798	4	Diesel	712		1338
8140.43S.4300 Euro 3 (D3)	94.40	2798	4	Diesel	712		1338
8140.43S.4320 Euro 3 (D3)	94.40	2798	4	Diesel	712		1338
8140.43S.4330 Euro 3 (D3)	94.40	2798	4	Diesel	712		1338
8140.43S.4400 Euro 3 (D3)	94.40	2798	4	Diesel	712		1338
8140.43S.4420 Euro 3 (D3)	94.40	2798	4	Diesel	712		1338
8140.43S.4430 Euro 3 (D3)	94.40	2798	4	Diesel	712		1338
8140.47	93.00	2500	4	Diesel	674		1313
8140.47.2700 Euro 1	93.00	2499	4	Diesel	652		1291
8140.47.2711 Euro 1	93.00	2499	4	Diesel	641		1292
8140.47.2721 Euro 1	93.00	2499	4	Diesel	653		1293
8140.47.2785 Euro 1	93.00	2499	4	Diesel	654		1294
8140.47.3700	93.00	2499	4	Diesel	655		1259
8140.47.3700 Euro 1	93.00	2499	4	Diesel	656		1295
8140.47.3711 Euro 1	93.00	2499	4	Diesel	657		1296
8140.47.3721 Euro 1	93.00	2499	4	Diesel	639		1296
8140.47.3731 Euro 1	93.00	2499	4	Diesel			1296
8140.47B.3790 Euro 1	93.00	2499	4	Diesel	639		1296
8140.47B.3795 Euro 1	93.00	2499	4	Diesel	639		1296
8140.47R	93.00	2499	4	Diesel	658		1297
8140.47R	93.00	2500	4	Diesel	675		1313
8140.47R.2210	93.00	2499	4	Diesel	659		1290
8140.47R.2790	93.00	2499	4	Diesel	660		1298
8140.47R.2795	93.00	2499	4	Diesel	639		1296
8140.47S Euro 1	93.00	2499	4	Diesel	661		1299
8140.61	93.00	2445	4	Diesel	618		1260







		ccm					
8140.61.200	93.00	2445	4	Diesel	619	1261	
8140.61.200	93.00	2445	4	Diesel	620	1262	
8140.61.204	93.00	2445	4	Diesel	621	1259	
8140.61.300	93.00	2445	4	Diesel	622	1263	
8140.63	94.40	2800	4	Diesel	737	1345	
8140.63. Euro 2	94.40	2798	4	Diesel	734	1343	
8140.63.4000 Euro 3 (D3)	94.40	2798	4	Diesel	733	1343	
8140.67	93.00	2500	4	Diesel	676	1314	
8140.67 (290B7W), 8144.67	93.00	2500	4	Diesel	613	1315	
8140.67.2585 Euro 2	93.00	2500	4	Diesel	677	1316	
8140.67.2700	93.00	2499	4	Diesel		1300	
8140.67F. Euro 2	93.00	2499	4	Diesel	663	1302	
8140.67F.3700 Euro 2	93.00	2499	4	Diesel	662	1301	
8140.67F.3701 Euro 2	93.00	2499	4	Diesel		1300	
8140.67F.3710 Euro 2	93.00	2499	4	Diesel		1300	
8140.67F.3711 Euro 2	93.00	2499	4	Diesel		1300	
8140.67F.3713 Euro 2	93.00	2499	4	Diesel		1300	
8140.67F.3721 Euro 2	93.00	2499	4	Diesel		1300	
8140.97.2781	93.00	2499	4	Diesel	664	1303	
8140.97.2783	93.00	2499	4	Diesel		1304	
8142.61	93.00	2445	4	Diesel	623	1264	
8144. 97S	93.00	2500	4	Diesel	681	1319	
8144.21	93.00	2445	4	Diesel	624	1265	
8144.21.220	93.00	2445	4	Diesel	625	1253	
8144.21.220	93.00	2445	4	Diesel	626	1266	
8144.61	93.00	2428	4	Diesel	612	1250	
8144.61	93.00	2445	4	Diesel	627	1267	
8144.61.200	93.00	2445	4	Diesel	628	1268	
8144.61.200	93.00	2445	4	Diesel	629	1269	
8144.61.200	93.00	2445	4	Diesel	630	1261	
8144.61.500.81	93.00	2445	4	Diesel	631	1270	
8144.65	88.00	1995	4	Diesel	577	1226	
8144.67	93.00	2500	4	Diesel	679	1318	
8144.67.220	93.00	2499	4	Diesel	665	1306	
8144.67.220	93.00	2499	4	Diesel	666	1305	
8144.81.2000	93.00	2445	4	Diesel	632	1259	
8144.91	93.00	2445	4	Diesel	633	1271	
8144.91.2000	93.00	2445	4	Diesel	634	1272	
8144.97	93.00	2499	4	Diesel	667	1308	
8144.97	93.00	2499	4	Diesel	668	1307	
8144.97 S	93.00	2500	4	Diesel	680	1307	
8144.97 Y	93.00	2500	4	Diesel	682	1320	
8144.97 Y	93.00	2500	4	Diesel	683	1319	
8144.97.2200	93.00	2499	4	Diesel		1296	
8144.97.2200	93.00	2499	4	Diesel	669	1309	
8144.97.2400	93.00	2499	4	Diesel		1296	
8144.97.2400	93.00	2499	4	Diesel	670	1307	
8144.97.2500	93.00	2500	4	Diesel		1296	
8149.03.3971	94.40	2798	4	Diesel	735		
828 A1.000	84.00	1756	4	Petrol		1082	
828 A2.000	80.00	1438	4	Petrol	145	889	
828 B.000	84.00	1585	V4	Petrol	385	1068	
828 B1.000	84.00	1995	4	Petrol	385	1068	
828 B4.000	84.00	1995	4	Petrol	445	1127	
828 B7.000	84.00	1995	4	Petrol	446	1078	
828 D3.000	78.00	1367	4	Petrol		852	
831 A1.000	86.40	1498	4	Petrol	534	1195	
831 A2.000	86.40	1301	4	Petrol	523	1187	
831 A4.000	84.00	1585	4	Petrol	386	1069	
831 A7.000	84.00	1585	4	Petrol	387	1070	
831 B.000	86.40	1301	4	Petrol	524	1187	
831 B1.000	86.40	1498	4	Petrol	535	1192	
831 B1.048	86.40	1498	4	Petrol	536	1192	
831 B3.000	84.00	1585	4	Petrol	388	1071	
831 B4.000	84.00	1995	4	Petrol	447	1128	
831 B5.000	84.00	1995	4	Petrol	448	1129	
831 B6.000	84.00	1585	4	Petrol	389	1072	
831 B7.000	84.00	1585	4	Petrol	390	1066	
831 B7.046	84.00	1585	4	Petrol	391	1073	
831 B8.000	80.00	1116	4	Petrol	129	877	
831 C5.000	84.00	1995	4	Petrol	449	1130	
831 C5.046	84.00	1995	4	Petrol	450	1131	
831 D.000	82.60	1911	4	Diesel	305	1000	
831 D1.000	82.60	1929	4	Diesel	321	1011	
831 D1.000	82.60	1929	4	Diesel	322	1012	
831 D5.000	84.00	1995	4	Petrol	451	1132	
831 E5.000	84.00	1995	4	Petrol	452	1125	
831 E5.046	84.00	1995	4	Petrol	452	1125	







		ccm	<b>X</b> 			<b>9</b>	
834 A.000	91.00	2849	V6	Petrol			1244
834 A1.000	72.00	1368	4	Petrol	71		826
834 B.000	84.00	1995	4	Petrol	453		1133
834 B.000	84.00	1995	4	Petrol	454		1134
834 B.048	84.00	1995	4	Petrol	455		1136
834 B.048	84.00	1995	4	Petrol	456		1135
834 B.146	84.00	1995	4	Petrol	457		1137
834 B.146	84.00	1995	4	Petrol	458		1135
834 B1.000	84.00	1995	4	Petrol	459		1135
834 B2.000	84.00	1995	4	Petrol	460		1138
834 B2.246	84.00	1995	4	Petrol	461		1139
834 C.000	84.00	1995	4	Petrol	462		1140
834 C.146	84.00	1995	4	Petrol	463		1140
834 C.146	84.00	1995	4	Petrol	464		1141
834 C1.000	84.00	1995	4	Petrol	465		1126
834 C1.246	84.00	1995	4	Petrol	466		1124
834 E.000	91.00	2849	6	Petrol			1244
834 E.146	91.00	2849	V6	Petrol			1244
834 F.000	93.00	2959	V6	Petrol	685		1322
834 F1.000	84.00	1995	4	Petrol	467		1121
834 F2.000	84.00	1995	4	Petrol	468		1126
834 G.000	88.00	2492	V6	Petrol	592		1237
835 A1.000	86.40	1581	4	Petrol	559		1213
835 A1.046	86.40	1581	4	Petrol	560		1214
835 A2.000	84.00	1756	4	Petrol	401		1083
835 A2.046	84.00	1756	4	Petrol	402		1084
835 A4.000	82.60	1929	4	Diesel	323		1013
835 A4.046	82.60	1929	4	Diesel	324		1013
835 A5.000	84.00	1995	4	Petrol	469		1142
835 A5.046	84.00	1995	4	Petrol	470		1143
835 A7.000	84.00	1995	4	Petrol	471		1129
835 A7.046	84.00	1995	4	Petrol	448		1129
835 A8.000	84.00	1995	4	Petrol	472		1144
835 A8.046	84.00	1995	4	Petrol	473		1145
835 C1.000	86.40	1581	4	Petrol	561		1214
835 C1.000	86.40	1581	4	Petrol	562		1215
835 C2.000	84.00	1756	4	Petrol	403		1085
835 C2.000	84.00	1756	4	Petrol	404		1083
835 C4.000	84.00	1756	4	Petrol	405		1084
835 C4.000	84.00	1756	4	Petrol	406		1086
835 C5.000	84.00	1756	4	Petrol	407		1087
836 A2.000	84.00	1995	4	Petrol	474		1125
836 A2.046	84.00	1756	4	Petrol			1088
836 A3.000	84.00	1995	4	Petrol	475		1121
836 A3.000	84.00	1995	4	Petrol	476		1121
836 A3.011	84.00	1995	4	Petrol	477		1146
836 A4.000	80.50	1372	4	Petrol	172		912
836 A4.000	80.50	1372	4	Petrol	178		915
836 A5.000	84.00	1756	4	Petrol	408		1084
836 A5.000	84.00	1756	4	Petrol	409		1089
836 A6.000	84.00	1756	4	Petrol	410		1090
836 A6.000	84.00	1756	4	Petrol	411		1091
836 C4.000	84.00	1756	4	Petrol	405		1084
838 A1.000	82.00	1998	5	Petrol	266		966
838 A2.000	83.00	2446	5	Petrol	355		1045
838 A2.027	83.00	2446	5	Petrol	355		1045
838 A3.000	82.00	2387	5	Diesel	271		974
838 A4.000	84.00	1995	4	Petrol	478		1147
838 A6.000	82.00	1998	5	Petrol	267		968
838 A7.000	82.00	2387	5	Diesel	271		974
838 A8.000	82.00	2387	5	Diesel	272		975
838 B.000	93.00	2959	V6	Petrol	686		1323
838 B2.000	83.00	2446	5	Petrol	356		1043
839 A4.000	82.00	1747	4	Petrol	200		929
839 A5.000	82.00	2387	5	Diesel	273		973
839 A6.000 Euro 3 (D3)	82.00	2387	5	Diesel	274		976
839 A6.000 Euro 3 (D3)	82.00	2387	5	Diesel	275		977
839 A7.000	82.00	1747	4	Petrol	201		931
839 A9.000	82.00	1747	4	Petrol	202		932
840 A2.000	82.00	1370	4	Petrol	186		923
840 A3.000	70.80	1242	4	Petrol	64		798
840 A4.000	82.00	1370	4	Petrol	186		923
841 A.000	93.00	2959	V6	Petrol	687		1324
841 C.000	82.00	2387	5	Diesel	276		977
841 C000	82.00	2387	5	Diesel	277		976
841 D.000	83.00	2446	5	Petrol	357		1043
841 E.000	82.00	1998	5	Petrol	268		971
841 G.000	82.00	2387	5	Diesel	278		978

		ccm					<b>9</b>
841 G.000	82.00	2387	5	Diesel	279	979	
841 H.000	82.00	2387	5	Diesel	280	981	
841 H.000	82.00	2387	5	Diesel	281	980	
841 M.000	82.00	2387	5	Diesel	282	978	
841 M.000	82.00	2387	5	Diesel	283	982	
841 N.000	82.00	2387	5	Diesel		984	
841 N.000	82.00	2387	5	Diesel	283	983	
841 P.000	82.00	2387	5	Diesel	284	985	
843 A 1.000	72.00	1368	4	Petrol	77	813	
844 A1.000	82.00	1910	4	Diesel		952	
844 A1.000	82.00	1910	4	Diesel	234	952	
844 A2.000	83.00	1956	4	Diesel		1034	
844 A2.000	83.00	1956	4	Diesel	342	1034	
844 A3.000	79.50	1598	4	Diesel		868	
903	65.00	903	4	Petrol	7	764	
932 A.000	93.00	3179	V6	Petrol	707		
932 A2.000	83.00	1970	4	Petrol	343	1036	
93313090-7U	80.50	1796	4	Petrol	183	919	
93313090-H2	80.50	1796	4	Petrol	183	919	
93337154-J1	80.50	1796	4	Petrol	183	919	
936 A.000	93.00	3179	V6	Petrol	708		
936 A6.000	93.00	3179	V6	Petrol	709		
936 B.000	82.00	2387	5	Diesel	285	986	
937 A1.000	83.00	1970	4	Petrol	344	1037	
937 A2.000	82.00	1910	4	Diesel	235	953	
937 A2.000	82.00	1910	4	Diesel	236	954	
937 A3.000	82.00	1910	4	Diesel	237	948	
937 A4.000	82.00	1910	4	Diesel	238	946	
937 A4.000	82.00	1910	4	Diesel	239	946	
937 A5.000	82.00	1910	4	Diesel		955	
937 A5.000	82.00	1910	4	Diesel	240	946	
937 A5.000	82.00	1910	4	Diesel	241	946	
937 A6.000	82.00	1910	4	Diesel	242	956	
937 A7.000	82.00	1910	4	Diesel	243	958	
937 A7.000	82.00	1910	4	Diesel	244	957	
937 A8.000	82.00	1910	4	Diesel	245	959	
939 A.000	87.30	3196	V6	Petrol	573		
939 A1.000	82.00	1910	4	Diesel	246	960	
939 A1.000	82.00	1910	4	Diesel	247	945	
939 A2.000	82.00	1910	4	Diesel	248	961	
939 A2.000	82.00	1910	4	Diesel	249	961	
939 A3.000	82.00	2387	5	Diesel	286	987	
939 A3.000 Euro 4 (D4)	82.00	2387	5	Diesel	287	988	
939 A4.000	80.50	1796	4	Petrol	182	917	
939 A4.000	80.50	1796	4	Petrol	182	918	
939 A5.000	86.00	2198	4	Petrol	518	1174	
939 A6.000	86.00	1859	4	Petrol	508	1174	
939 A7.000	82.00	1910	4	Diesel	227	960	
939 A7.000	82.00	1910	4	Diesel	250	960	
939 A8.000	82.00	1910	4	Diesel	251	963	
939 A8.000	82.00	1910	4	Diesel	252	962	
939 A9.000	82.00	2387	5	Diesel	288	989	
939 B1.000	83.00	1742	4	Petrol	329	1019	
939 B3.000	83.00	1956	4	Diesel	341	1032	
939 B4.000	83.00	1956	4	Diesel	340	1035	
939 B5.000	83.00	1956	4	Diesel	340	1035	
940 A1.000	83.00	1742	4	Petrol	329	1020	
940 A2.000 Euro 5	72.00	1368	4	Petrol	78	820	
940 A3.000	79.50	1598	4	Diesel	116	869	
940 A4.000	83.00	1956	4	Diesel	341	1030	
940 A5.000 Euro 5	83.00	1956	4	Diesel	340	1035	
940 A6.000 Euro 5	72.00	1368	4	Petrol	79	827	
940 A7.000 Euro 5	83.00	1956	4	Diesel		1035	
940 A8.000 Euro 5	83.00	1956	4	Diesel		1035	
940 B1.000	72.00	1368	4	Petrol	80	828	
944 A 3.000	79.50	1598	4	Diesel	117	866	
955 A1.000	72.00	1368	4	Petrol	79	813	
955 A2.000 Euro 5	72.00	1368	4	Petrol	78	821	
955 A2.000 Euro 5	72.00	1368	4	Petrol	79	821	
955 A3.000 Euro 5	79.50	1598	4	Diesel	116	864	
955 A4.000	79.50	1598	4	Diesel	116	869	
955 A4.000	79.50	1598	4	Diesel	117	869	
955 A6.000 Euro 5	72.00	1368	4	Petrol	79	821	
955 A6.000 Euro 5	72.00	1368	4	Petrol	81	821	
955 A7.000	72.00	1368	4	Petrol	78	820	
955 A8.000 Euro 5	72.00	1368	4	Petrol	78	820	
955 A8.000 Euro 5	72.00	1368	4	Petrol	79	820	







		ccm	X 			<b>9</b>	
955 A9.000	72.00	1368	4	Petrol		82	829
9HU	75.00	1560	4	Diesel		86	838
A 112 AB.2C.0	67.20	1050	4	Petrol			768
A 112 B1.054	67.20	965	4	Petrol		20	770
A112 A.000	65.00	903	4	Petrol		16	765
A112 A2.000	67.20	1050	4	Petrol		18	767
A112 A5.000	65.00	903	4	Petrol		16	766
A112 B1.000	67.20	965	4	Petrol		19	769
A112 B2.000	65.00	903	4	Petrol		17	765
AR 00112	78.00	1570	4	Petrol			855
AR 00121	78.00	1570	4	Petrol			855
AR 00500	74.00	1290	4	Petrol			833
AR 00501	74.00	1290	4	Petrol			833
AR 00502	74.00	1290	4	Petrol			833
AR 00504	74.00	1290	4	Petrol			833
AR 00506	74.00	1290	4	Petrol			834
AR 00508	74.00	1290	4	Petrol			833
AR 00510	74.00	1290	4	Petrol			833
AR 00512	84.00	1962	4	Petrol	414		1097
AR 00514	74.00	1290	4	Petrol			833
AR 00515	84.00	1962	4	Petrol	415		1098
AR 00516	78.00	1570	4	Petrol			855
AR 00526	78.00	1570	4	Petrol	108		856
AR 00526 S	78.00	1570	4	Petrol			857
AR 00530	74.00	1290	4	Petrol	84		835
AR 00536	78.00	1570	4	Petrol	109		856
AR 00548	80.00	1779	4	Petrol	152		898
AR 01212	84.00	1962	4	Petrol			1099
AR 01354	80.00	1779	4	Petrol	153		899
AR 01544	84.00	1962	4	Petrol	416		1100
AR 01563	78.10	1570	4	Petrol	113		860
AR 01588	84.00	1962	4	Petrol	417		1101
AR 01590	84.00	1962	4	Petrol	418		1098
AR 01600	78.00	1570	4	Petrol	110		856
AR 01608	80.00	1779	4	Petrol	154		898
AR 01608 X	80.00	1779	4	Petrol	155		898
AR 01615	84.00	1962	4	Petrol			1098
AR 01623	84.00	1962	4	Petrol	419		1102
AR 01644	80.00	1357	4	Petrol	142		886
AR 01646	88.00	2492	V6	Petrol	593		1238
AR 01648	88.00	2492	V6	Petrol	594		1239
AR 01655	84.00	1962	4	Petrol	420		1103
AR 01678	80.00	1779	4	Petrol	154		898
AR 01699	84.00	1962	4	Petrol			1104
AR 01713	84.00	1962	4	Petrol	421		1098
AR 01911	88.00	2492	V6	Petrol	595		1238
AR 01913	88.00	2492	V6	Petrol			1240
AR 01928	88.00	2492	V6	Petrol	596		1238
AR 01932	80.00	1997	V6	Petrol			903
AR 06100	78.00	1567	4	Petrol	107		854
AR 06120	93.00	2959	V6	Petrol	688		1325
AR 06124	93.00	2959	V6	Petrol	688		1325
AR 06134	80.00	1779	4	Petrol	156		899
AR 06158	80.00	1779	4	Petrol	156		899
AR 06166	84.00	1962	4	Petrol	422		1105
AR 06168	80.00	1779	4	Petrol	157		898
AR 06202	80.00	1779	4	Petrol	157		898
AR 06210	80.00	1997	V6	Petrol	163		903
AR 06212	84.00	1962	4	Petrol	421		1103
AR 06224	84.00	1962	4	Petrol	422		1106
AR 06410	93.00	2959	V6	Petrol	689		1326
AR 06412	93.00	2959	V6	Petrol	689		1326
AR 06416	84.00	1995	4	Petrol	422		1149
AR 06420	84.00	1995	4	Petrol	422		1149
AR 06430	93.00	2959	V6	Petrol	690		1324
AR 06476	84.00	1995	4	Petrol	480		1150
AR 10512	84.00	1962	4	Petrol	423		1107
AR 10520	84.00	1962	4	Petrol	424		1108
AR 10527	84.00	1962	4	Petrol	425		1098
AR 10531	74.00	1290	4	Petrol			836
AR 10534	74.00	1290	4	Petrol			836
AR 10538	78.10	1570	4	Petrol			861
AR 10548	80.00	1779	4	Petrol			899
AR 11633	84.00	1962	4	Petrol			1107
AR 11634	84.00	1962	4	Petrol			1099
AR 11642	84.00	1962	4	Petrol	426		1104
AR 11644	80.00	1357	4	Petrol			886
AR 11650	78.00	1570	4	Petrol			855

		ccm					<b>9</b>
AR 11655	84.00	1962	4	Petrol			1099
AR 11671	84.00	1962	4	Petrol	425		1102
AR 11900	88.00	2492	V6	Petrol			1241
AR 16101	93.00	2959	V6	Petrol	691		1327
AR 16102	93.00	2959	V6	Petrol	692		1323
AR 16105	93.00	2959	V6	Petrol	693		1323
AR 16199	93.00	2959	V6	Petrol			1324
AR 16201	83.00	1970	4	Petrol	345		1038
AR 16202	80.00	1996	V6	Petrol	159		901
AR 19510	84.00	1962	4	Petrol			1107
AR 19520	93.00	2959	6	Petrol			1324
AR 30100	80.00	1351	4	Petrol	135		884
AR 30102	80.00	1186	4	Petrol	130		878
AR 30102 S	80.00	1186	4	Petrol	130		879
AR 30104	80.00	1186	4	Petrol	131		880
AR 30124	84.00	1490	4	Petrol	361		1049
AR 30128	84.00	1490	4	Petrol	361		1049
AR 30143	84.00	1490	4	Petrol	362		1050
AR 30146	84.00	1490	4	Petrol	363		1049
AR 30160	80.00	1351	4	Petrol	131		878
AR 30164	80.00	1351	4	Petrol	136		880
AR 30168	80.00	1351	4	Petrol	137		880
AR 30180	80.00	1286	4	Petrol	134		879
AR 30182	84.00	1490	4	Petrol	364		1049
AR 30184	84.00	1286	4	Petrol	360		1048
AR 30198	84.00	1490	4	Petrol			1051
AR 30500	80.00	1186	4	Petrol	130		881
AR 30502	80.00	1351	4	Petrol	138		880
AR 30504	84.00	1490	4	Petrol	365		1049
AR 30508	84.00	1490	4	Petrol	363		1049
AR 30514	84.00	1490	4	Petrol	366		1052
AR 30520	84.00	1490	4	Petrol	361		1049
AR 30550	87.00	1712	4	Petrol	563		1216
AR 30558	87.00	1712	4	Petrol	564		1217
AR 30578	87.00	1712	4	Petrol			1218
AR 30585	80.00	1186	4	Petrol	132		882
AR 30586	80.00	1351	4	Petrol	138		880
AR 30587	80.00	1351	4	Petrol	138		878
AR 30588	84.00	1490	4	Petrol	367		1053
AR 30732	80.00	1351	4	Petrol			879
AR 30734	84.00	1490	4	Petrol	368		1051
AR 30736	87.00	1712	4	Petrol	565		1217
AR 30737	87.00	1712	4	Petrol	565		1217
AR 30737 A	87.00	1712	4	Petrol	566		1219
AR 30738	84.00	1490	4	Petrol			1051
AR 30740	87.00	1712	4	Petrol	567		1220
AR 30743	80.00	1186	4	Petrol			883
AR 30746	87.00	1712	4	Petrol	568		1221
AR 30747	87.00	1712	4	Petrol	568		1221
AR 30750	84.00	1490	4	Petrol	369		1054
AR 30751	84.00	1490	4	Petrol	370		1054
AR 30753	80.00	1351	4	Petrol	139		885
AR 30755	80.00	1351	4	Petrol	140		885
AR 31000	80.00	1186	4	Petrol	133		878
AR 31010	80.00	1351	4	Petrol	141		878
AR 31016	84.00	1490	4	Petrol			1051
AR 32101	82.00	1598	4	Petrol	188		925
AR 32102	82.00	1598	4	Petrol	189		926
AR 32103 D4	82.00	1598	4	Petrol	190		927
AR 32104	82.00	1598	4	Petrol	190		927
AR 32201	82.00	1747	4	Petrol	203		933
AR 32205	82.00	1747	4	Petrol	204		933
AR 32301	83.00	1970	4	Petrol	346		1038
AR 32302	82.00	1910	4	Diesel	253		937
AR 32302	82.00	1910	4	Diesel	254		937
AR 32303	83.00	1970	4	Petrol	347		1039
AR 32310 D4	83.00	1970	4	Petrol	348		1040
AR 32401	88.00	2492	V6	Petrol	597		1242
AR 32402	88.00	2492	V6	Petrol			1241
AR 32405	88.00	2492	V6	Petrol	598		1242
AR 32501	82.00	2387	5	Diesel	273		975
AR 32501	82.00	2387	5	Diesel	289		973
AR 33201	84.00	1596	4	Petrol	393		1074
AR 33401	87.00	1712	4	Petrol	569		1221
AR 33501	80.00	1351	4	Petrol	140		885
AR 33503	82.00	1370	4	Petrol	187		924
AR 33601	82.60	1929	4	Diesel	325		1014
AR 34102	80.00	1996	V6	Petrol	160		901

		ccm	X 			<b>9</b>	
AR 34103	83.00	1970	4	Petrol		349	1038
AR 34201	88.00	2492	V6	Petrol		597	1242
AR 34202	82.00	2387	5	Diesel		290	973
AR 34301	93.00	2959	V6	Petrol		694	1323
AR 34302	93.00	2959	V6	Petrol		695	1324
AR 36101	93.00	2959	V6	Petrol		696	1323
AR 36201	88.00	2492	V6	Petrol		599	1242
AR 36202	82.00	2387	5	Diesel		291	990
AR 36301 D4	83.00	1970	4	Petrol		350	1040
AR 37101	82.00	1910	4	Diesel		255	964
AR 37101	82.00	1910	4	Diesel		256	954
AR 37203	82.00	1598	4	Petrol		191	928
AR 38201	82.00	1598	4	Petrol		192	926
AR 38401	82.00	1747	4	Petrol		205	933
AR 38501	82.00	1370	4	Petrol		187	924
AR 61101	78.10	1567	4	Petrol		112	859
AR 61102	80.00	1779	4	Petrol		157	898
AR 61201	80.00	1779	4	Petrol		158	900
AR 61202	80.00	1779	4	Petrol		158	899
AR 61203	80.00	1779	4	Petrol			899
AR 61501	93.00	2959	V6	Petrol		697	1324
AR 61503	93.00	2959	V6	Petrol		688	1325
AR 64101	80.00	1996	V6	Petrol		161	902
AR 64102	80.00	1996	V6	Petrol		162	902
AR 64103	84.00	1995	4	Petrol		412	1151
AR 64301	93.00	2959	V6	Petrol		698	1326
AR 64303	93.00	2959	V6	Petrol		699	
AR 64304	93.00	2959	V6	Petrol		700	1328
AR 64305	93.00	2959	V6	Petrol		701	1327
AR 64306	93.00	2959	V6	Petrol		702	1324
AR 64307	93.00	2959	V6	Petrol		703	1324
AR 64308	93.00	2959	V6	Petrol		704	1324
AR 64399	93.00	2959	V6	Petrol		705	1324
AR 66201	88.00	2492	V6	Petrol		600	1241
AR 66301	93.00	2959	V6	Petrol		704	1324
AR 66302	93.00	2959	6	Petrol		704	1324
AR 66303	93.00	2959	V6	Petrol		701	1327
AR 66304	93.00	2959	V6	Petrol			1324
AR 66306	93.00	2959	V6	Petrol		706	1324
AR 67101	84.00	1773	4	Petrol		412	1093
AR 67102	84.00	1773	4	Petrol		412	1093
AR 67103	83.40	1748	4	Petrol		358	1046
AR 67105	83.50	1748	4	Petrol		359	1047
AR 67106	82.00	1747	4	Petrol		206	933
AR 67199	82.00	1747	4	Petrol		207	934
AR 67201	84.00	1995	4	Petrol		481	1151
AR 67202	83.00	1995	4	Petrol		353	1042
AR 67203	84.00	1995	4	Petrol		482	1152
AR 67204	83.00	1970	4	Petrol		351	1038
AR 67299	83.00	1970	4	Petrol		352	1041
AR 67301	88.00	2492	V6	Petrol		601	1243
AR 67302	88.00	2492	V6	Petrol		602	1243
AR 67303	88.00	2492	V6	Petrol		603	1243
AR 67402	84.00	1756	4	Petrol		412	1092
AR 67501	82.60	1929	4	Diesel		326	1014
AR 67502	82.60	1929	4	Diesel			1015
AR 67601	82.00	1598	4	Petrol		193	926
B 25.637	93.00	2498	4	Diesel			1273
CRD93L (U25-661)	93.00	2500	4	Diesel		684	1321
D19AA	82.00	1910	4	Diesel		257	950
D20AA Euro 5	83.00	1956	4	Diesel		340	1032
D8B	83.00	1905	4	Diesel		331	1022
D8B (XUD9TE)	83.00	1905	4	Diesel		332	1023
D9B	83.00	1905	4	Diesel		333	1024
D9B (XUD9A)	83.00	1905	4	Diesel		334	1025
DHX	83.00	1905	4	Diesel		337	1027
DHX (XUD9TE)	83.00	1905	4	Diesel		335	1023
DHX (XUD9TF/L)	83.00	1905	4	Diesel		336	1026
DJY	83.00	1905	4	Diesel		339	1029
DJY (XUD9)	83.00	1905	4	Diesel		338	1028
DW10BTED4	85.00	1997	4	Diesel		483	1154
ES9 J4S	87.00	2946	V6	Petrol		570	1222
F1AE 0481 C	88.00	2287	4	Diesel		584	1231
F1AE0481A Euro 3 (D3)	88.00	2287	4	Diesel		582	1229
F1AE0481B Euro 3 (D3)	88.00	2287	4	Diesel		583	1229
F1AE0481C	88.00	2286	4	Diesel		580	1229
F1AE0481D Euro 4 (D4)	88.00	2287	4	Diesel		585	1232
F1AE0481F Euro 4 (D4)	88.00	2287	4	Diesel		587	1230

		ccm					<b>9</b>
F1AE0481FA Euro 4 (D4)	88.00	2287	4	Diesel	586	1232	
F1AE0481G Euro 4 (D4)	88.00	2287	4	Diesel	587	1230	
F1AE0481GA Euro 4 (D4)	88.00	2287	4	Diesel	586	1232	
F1AE0481H Euro 4 (D4)	88.00	2287	4	Diesel	587	1230	
F1AE0481HA Euro 4 (D4)	88.00	2287	4	Diesel	586	1232	
F1AE0481M	88.00	2287	4	Diesel	588	1232	
F1AE0481N	88.00	2287	4	Diesel	589	1233	
F1AE0481R Euro 4 (D4)	88.00	2287	4	Diesel	590	1230	
F1AE0481T	88.00	2286	4	Diesel	581	1230	
F1AE0481U Euro 4 (D4)	88.00	2287	4	Diesel	587	1234	
F1AE0481V Euro 4 (D4)	88.00	2287	4	Diesel	587	1234	
F1AE3481A Euro 5	88.00	2287	4	Diesel	587	1234	
F1AE3481B Euro 5	88.00	2287	4	Diesel	587	1234	
F1AE3481C Euro 5	88.00	2287	4	Diesel	587	1234	
F1AE3481D	88.00	2287	4	Diesel	591	1235	
F1AE3481E	88.00	2287	4	Diesel	589	1235	
F1AE3481G	88.00	2287	4	Diesel	589	1236	
F1CE0441A	95.80	2999	4	Petrol	745		
F1CE0441A EEV	95.80	2998	4	Gas		1351	
F1CE0481A	95.80	2998	4	Diesel	742	1352	
F1CE0481B Euro 3 (D3)	95.80	2998	4	Diesel	742	1352	
F1CE0481D Euro 4 (D4)	95.80	2999	4	Diesel	746	1353	
F1CE0481FA Euro 4 (D4)	95.80	2998	4	Diesel	743	1352	
F1CE0481HA EEV	95.80	2998	4	Diesel	743	1354	
F1CE0481HC Euro 4 (D4)	95.80	2998	4	Diesel	743	1354	
F1CE0481L Euro 4 (D4)	95.80	2998	4	Diesel		1353	
F1CE3481E Euro 5	95.80	2999	4	Diesel	747		
F1CE3481LC EEV	95.80	2998	4	Diesel	744		
F1CE3481M Euro 5	95.80	2999	4	Diesel	747		
F1CE3481N Euro 5	95.80	2999	4	Diesel	747		
J2	80.50	1796	4	Petrol	183	919	
KFT	75.00	1360	4	Petrol	85	837	
KFV	75.00	1360	4	Petrol	85	837	
LFW	83.00	1761	4	Petrol	330	1021	
M 624 AA 30.A	93.00	2959	6	Petrol		1324	
M 624 AB 30.A	93.00	2959	6	Petrol		1324	
M020 AA.09.0	65.00	903	4	Petrol		754	
M16A Euro4/Euro5	78.00	1586	4	Petrol	111	858	
P 8 C	85.00	2088	4	Diesel	500	1166	
P8C	85.00	2088	4	Diesel	499	1167	
PN93327668	80.50	1796	4	Petrol	183	919	
PN93327669	80.50	1796	4	Petrol	183	919	
RFH (EW10A) Euro 4 (D4)	85.00	1997	4	Petrol	484	1155	
RFL	86.00	1998	4	Petrol	509	1175	
RFN	85.00	1997	4	Petrol	487	1157	
RFN (EW10J4)	85.00	1997	4	Petrol	485	1156	
RFN (EW10J4)	85.00	1997	4	Petrol	486	1156	
RFU (XU10J2C)	86.00	1998	4	Petrol	510	1176	
RFV	86.00	1998	4	Petrol	512	1178	
RFV (XU10J4R)	86.00	1998	4	Petrol	511	1177	
RFW	86.00	1998	4	Petrol	513	1176	
RGX (XU10J2CTE)	86.00	1998	4	Petrol	514	1179	
RGX (XU10J2TE)	86.00	1998	4	Petrol	515	1180	
RH02	85.00	1997	4	Diesel	488	1153	
RHH Euro 5	85.00	1997	4	Diesel	488	1158	
RHK	85.00	1997	4	Diesel	489	1160	
RHK (DW10UTED4) Euro 4 (D4)	85.00	1997	4	Diesel	483	1159	
RHM (DW10ATED4)	85.00	1997	4	Diesel	490	1161	
RHM (DW10ATED4)	85.00	1997	4	Diesel	491	1159	
RHR	85.00	1997	4	Diesel	493	1162	
RHR (DW10BTED4) Euro 4 (D4)	85.00	1997	4	Diesel	492	1162	
RHV (DW10)	85.00	1997	4	Diesel	494	1163	
RHW (DW10ATED4)	85.00	1997	4	Diesel	495	1162	
RHW (DW10ATED4)	85.00	1997	4	Diesel	496	1164	
RHX	85.00	1997	4	Diesel	497	1165	
RHZ	85.00	1997	4	Diesel	497	1165	
RHZ (DW10ATED)	85.00	1997	4	Diesel	498	1159	
THY (DK5ATE)	92.00	2446	4	Diesel		1247	
VM 07 B	92.00	2499	4	Diesel	608	1248	
VM 08 B	92.00	2499	4	Diesel	609	1248	
VM 31 B	92.00	2499	4	Diesel	609	1248	
VM 32 B	92.00	2499	4	Diesel	610	1248	
VM 4 HT	88.00	1995	4	Diesel	578	1227	
VM 5 HT	88.00	2494	5	Diesel		1227	
VM 80 A	88.00	1995	4	Diesel	579	1228	
VM 81 A	92.00	2393	4	Diesel	607	1245	
VM 82 A	92.00	1779	3	Diesel	605	1245	
VM 84 A	92.00	2499	4	Diesel	611	1248	



		ccm	<b>X</b> 			<b>9</b>	
VM 96 A	92.00	1779	3	Diesel	<b>605</b>		<b>1245</b>
VM-425 CHIEA 08 B	92.00	2499	4	Diesel			<b>1249</b>
VM-425 SLIRA	92.00	2500	4	Diesel			<b>1249</b>
VM4HT 2.4	92.00	2393	4	Diesel	<b>606</b>		<b>1246</b>
VM4HT/2	88.00	1995	4	Diesel	<b>579</b>		<b>1228</b>
VM-HR 588 HT	88.00	2493	5	Diesel	<b>604</b>		<b>1228</b>
WJY (DW8)	82.20	1868	4	Diesel	<b>292</b>		<b>991</b>
WJY (DW8B)	82.20	1868	4	Diesel	<b>293</b>		<b>991</b>
WJZ (DW8)	82.20	1868	4	Diesel	<b>294</b>		<b>992</b>
XFW	87.00	2946	V6	Petrol	<b>571</b>		
XFW	87.00	2946	V6	Petrol	<b>572</b>		<b>1223</b>
XM7T	84.00	1796	4	Petrol			<b>1095</b>
XN 1T	88.00	1971	4	Petrol	<b>576</b>		<b>1225</b>
Y2	80.50	1796	4	Petrol	<b>183</b>		<b>919</b>



# TOP ENGINE APPLICATIONS

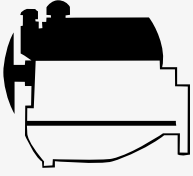

ZYLINDERKOPFANWENDUNGEN

APPLICAZIONI PARTE ALTA DEL MOTORE

APPLICATIONS HAUT MOTEUR

APLICACIONES PARA LA PARTE SUPERIOR DEL MOTOR

GÓRA SILNIKA

ДЕТАЛИ ВЕРХНЕЙ ЧАСТИ ДВИГАТЕЛЯ







تطبيقات المحرك العلوية









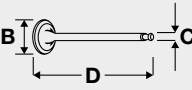
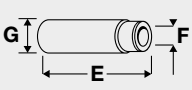

# FIAT GROUP

## 1 65.00 Petrol

141 B.000 4 Cyl. 9.2:1 769cc 25kW (34)PS TD4370 749

					
<b>TB129</b> 104x15 10/88 → 04/91	<b>TBK006</b> 10/88 → 04/91 Component No: TB129; AE1008TP		<b>KIT</b>		

	
B x C x D	Ex F x G
<b>V91286</b> ■ 26.30 x 7.00 x 97.20	<b>VAG92364</b> ■ ■ ■ 42.50 x 7.00 x 13.07
<b>V91287</b> ■ 23.30 x 7.00 x 97.20	







							
<b>BP520</b> Fibre Composite, 1.200mm <b>BP030</b> Fibre Composite, 1.800mm	<b>DR611</b> Eng.8061128 → <b>DS570</b> Eng.8061128 →	<b>GR611</b>	<b>HBS297</b> Ⓢ M9x1.25x91.00mm (x9)	<b>JC973</b> ■	<b>JM333</b>	<b>HR599</b> ■	









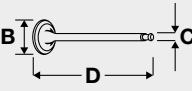
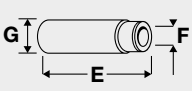

BP520, BP030

## 2 65.00 Petrol

156 A4.000 4 Cyl. 9.4:1 770cc 25kW (34)PS TD11307 750









					
<b>TB129</b> 104x15 05/86 →	<b>TBK006</b> 05/86 → Component No: TB129; AE1008TP		<b>KIT</b>		





	
B x C x D	Ex F x G
<b>V91286</b> ■ 26.30 x 7.00 x 97.20	<b>VAG92364</b> ■ ■ ■ 42.50 x 7.00 x 13.07
<b>V91287</b> ■ 23.30 x 7.00 x 97.20	





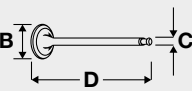
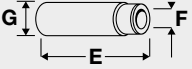







							
<b>BP660</b> Fibre Composite	<b>DP660</b>	<b>GP660</b>	<b>HBS052</b> Ⓢ M9x1.25x95.00mm (x10)	<b>JD148</b> ■ <b>JC660</b> ■	<b>JN667</b>	<b>HR599</b> ■	<b>NA5053</b> 30.00x42.00x7.00mm FPM



BP660



<b>3</b>  <b>65.00</b> <b>Petrol</b> 					
<b>156 A4.048</b>	<b>4 Cyl.</b> <b>9.4:1</b> <b>770cc</b> <b>25kW (34)PS</b> <b>TD11308</b> <b>750</b>				
					
<b>TB129</b> 104x15	<b>TBK006</b> Component No: TB129; AE1008TP		<b>KIT</b>		









	
<b>B x C x D</b>	<b>E x F x G</b>
<b>V91286</b> 	<b>VAG92364</b> 
26.30 x 7.00 x 97.20	42.50 x 7.00 x 13.07
<b>V91287</b> 	
23.30 x 7.00 x 97.20	

							
<b>BP660</b> Fibre Composite	<b>DP660</b>	<b>GP660</b>	<b>HBS052</b>  M9x1.25x95.00mm (x10)	<b>JD148</b>  <b>JC660</b> 	<b>JN667</b>	<b>HR599</b> 	<b>NA5053</b> 30.00x42.00x7.00mm FPM

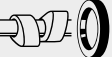

BP660

<b>4</b>  <b>65.00</b> <b>Petrol</b> 	
<b>100 G.000</b>	<b>4 Cyl.</b> <b>8:1</b> <b>843cc</b> <b>25kW (34)PS</b> <b>TD863</b> <b>751</b>
<b>100 G.002</b>	<b>4 Cyl.</b> <b>8.8:1</b> <b>843cc</b> <b>27kW (37)PS</b> <b>TD864</b> <b>752</b>
<b>100 GB.000</b>	<b>4 Cyl.</b> <b>8.8:1</b> <b>843cc</b> <b>35kW (47)PS</b> <b>TD865</b> <b>753</b>
<b>100 GC.000</b>	<b>4 Cyl.</b> <b>9.3:1</b> <b>843cc</b> <b>38kW (52)PS</b> <b>TD868</b> <b>752</b>

						
<b>BP520</b> Fibre Composite, 1.200mm	<b>DP013</b> <b>DR610</b>	<b>GP013</b>	<b>JC973</b> 	<b>JN333</b>	<b>HR599</b> 	



BP520

# FIAT GROUP

**5**



**65.00**

**Petrol**



1170 A1.000

4 Cyl.

899cc

29-30kW (40-41)PS

TD1030

**755**



**FOL161** (x8)  
Eng: 9127270→

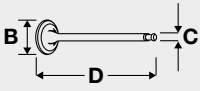

B x C x D

OE



MAT.



45°



H

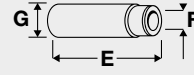

E x F x G

**V34457** ■  
29.10 x 7.02 x 95.65  
**V94576** ■  
29.00 x 7.00 x 95.10  
**V91282** ■  
26.00 x 7.00 x 95.50

4 265 695  
46 407 749  
7 783 841

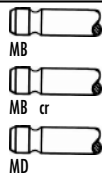

45°  
45°  
45°

H  
H

**VAG92364** ■ ■  
42.50 x 7.00 x 13.07

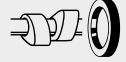
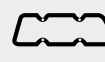

**AY430** Fibre Composite  
**BT260** Fibre Composite

**DT260**

**GP011**  
**GT260** [3]

**HBS297** Ⓢ  
M9x1.25x91.00mm (x9)

**JC973** ■

**JN803**

**HR599** ■



**AY430, BT260**

[3] Specification: Contains JJ449

[3] Caractéristiques : Contient JJ449

[3] Specifiche: Contiene JJ449

[3] Especificaciones: Contiene JJ449

**6**



**65.00**

**Petrol**



1170 A1.046

4 Cyl.

8.8:1

899cc

29kW (39)PS

TD872

**756**



**FOL119** (x8)  
Eng: →9127269  
**FOL161** (x8)  
Eng: 9127270→

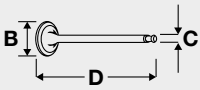

B x C x D

OE



MAT.



45°



H

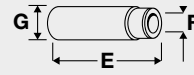

E x F x G

**V34457** ■  
29.10 x 7.02 x 95.65  
**V94576** ■  
29.00 x 7.00 x 95.10  
**V91282** ■  
26.00 x 7.00 x 95.50

4 265 695  
46 407 749  
7 783 841

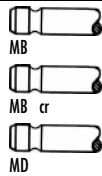

45°  
45°  
45°

H  
H

**VAG92364** ■ ■  
42.50 x 7.00 x 13.07

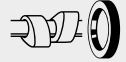
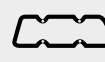

**BT260** Fibre Composite

**DT260**

**GT260** [3]

**HBS297** Ⓢ  
M9x1.25x91.00mm (x9)

**JC973** ■

**JN803**

**HR599** ■





**BT260**

[3] Specification: Contains JJ449



[3] Caractéristiques : Contient JJ449

[3] Specifiche: Contiene JJ449

[3] Especificaciones: Contiene JJ449

<b>7</b>		 <b>65.00</b>		<b>Petrol</b>			
100 GBC.000	4 Cyl.	9.5:1	903cc	<b>38kW (52)PS</b>	<b>TD866</b>	<b>757</b>	
100 GBS.000	4 Cyl.		903cc	<b>38kW (52)PS</b>	<b>TD867</b>	<b>754</b>	
903	4 Cyl.		903cc	<b>33kW (45)PS</b>	<b>TD6824</b>	<b>764</b>	



<b>8</b>		 <b>65.00</b>		<b>Petrol</b>			
100 GF 000	4 Cyl.	7.8:1	903cc	<b>26kW (35)PS</b>	<b>TD6939</b>	<b>758</b>	
100 GL.000	4 Cyl.	9:1	903cc	<b>30-33kW (41-45)PS</b>	<b>TD870</b>	<b>758</b>	

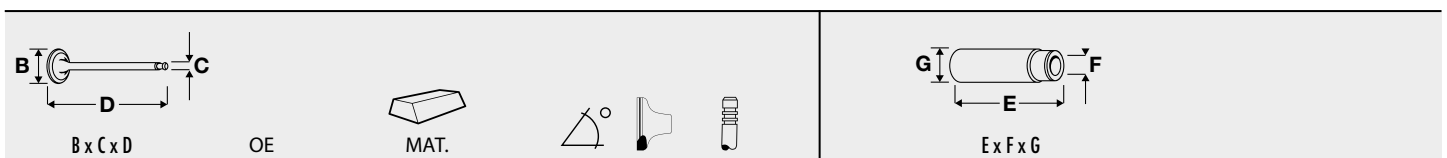

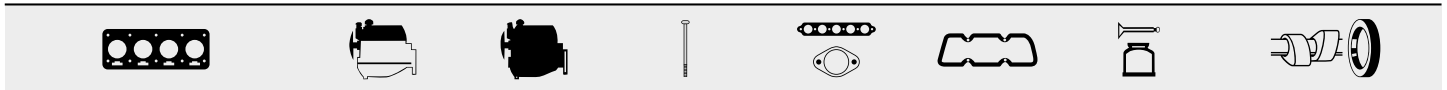

B x C x D	OE	MAT.	Angle	Part	E x F x G
<b>V34457</b> ■	4 265 695		45°	H	<b>VAG92364</b> ■ ■
29.10 x 7.02 x 95.65		MB			42.50 x 7.00 x 13.07
<b>V91282</b> ■	7 783 841		45°		
26.00 x 7.00 x 95.50		MD			



BP520 Fibre Composite, 1.200mm	<b>CG01A</b> ▲	<b>GP011</b>	<b>HBS279</b> △	<b>JC973</b> ■	<b>JM333</b>	<b>HR599</b> ■	
BP030 Fibre Composite, 1.800mm	→Eng.8064870	→Eng.8064870	M11x1.50x154.00mm (x6)				
	<b>DP011</b>						
	→Eng.8064870						
	<b>DR610</b>						
	→Eng.8064870						



BP520, BP030

<b>9</b>		 <b>65.00</b>		<b>Petrol</b>			
100 GL.048	4 Cyl.	7.8:1	903cc	<b>29kW (40)PS</b>	<b>TD4413</b>	<b>751</b>	

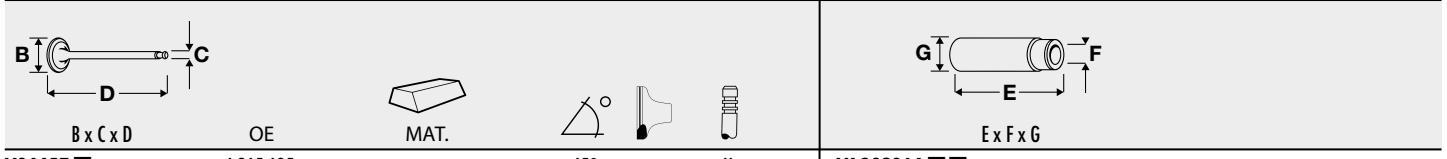

B x C x D	OE	MAT.	Angle	Part	E x F x G
<b>V34457</b> ■	4 265 695		45°	H	<b>VAG92364</b> ■ ■
29.10 x 7.02 x 95.65		MB			42.50 x 7.00 x 13.07
<b>V91282</b> ■	7 783 841		45°		
26.00 x 7.00 x 95.50		MD			

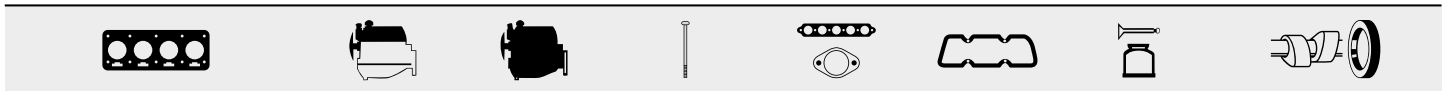

	<b>DR610</b>		<b>HBS279</b> △		<b>HR599</b> ■		
			M11x1.50x154.00mm (x6)				

# FIAT GROUP

<b>10</b>	<b>65.00</b>	<b>Petrol</b>							
<b>100 GL3.000</b>	4 Cyl.	9:1	903cc	<b>33kW (45)PS</b>				<b>TD869</b>	<b>760</b>

B x C x D	OE	MAT.			E x F x G
<b>V34457</b>	4 265 695		45°	H	<b>VAG92364</b>
29.10 x 7.02 x 95.65		MB			42.50 x 7.00 x 13.07
<b>V91282</b>	7 783 841		45°		
26.00 x 7.00 x 95.50		MD			

<b>BP520</b> Fibre Composite, 1.200mm	<b>CG01A</b> ▲	<b>GP011</b>	<b>HBS297</b> ①	<b>JC973</b>	<b>JM333</b>	<b>HR599</b>	
<b>BP030</b> Fibre Composite, 1.800mm	→Eng.8064870		M9x1.25x91.00mm (x9)				
	<b>DP011</b>						
	→Eng.8064870						
	<b>DR610</b>						



BP520, BP030

<b>11</b>	<b>65.00</b>	<b>Petrol</b>							
<b>146 A.000</b>	4 Cyl.	9:1	903cc	<b>33kW (45)PS</b>				<b>TD4371</b>	<b>761</b>









B x C x D	OE	MAT.			E x F x G
<b>V34457</b>	4 265 695		45°	H	<b>VAG50895</b>
29.10 x 7.02 x 95.65		MB			46.00 x 7.04 x 13.03
<b>V91282</b>	7 783 841		45°		<b>VAG92364</b>
26.00 x 7.00 x 95.50		MD			42.50 x 7.00 x 13.07
<b>V91766</b>	7 783 861		45°		
26.00 x 7.00 x 95.50		MD			



<b>BP520</b> Fibre Composite, 1.200mm	<b>CG01A</b> ▲	<b>GP011</b>	<b>HBS297</b> ①	<b>JC973</b>	<b>JM333</b>	<b>HR599</b>	
<b>BP030</b> Fibre Composite, 1.800mm	→Eng.8064870	→Eng.8064870	M9x1.25x91.00mm (x9)				
	<b>DP011</b>						
	→Eng.8064870						
	<b>DR610</b>						



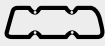







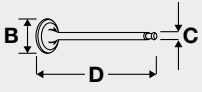



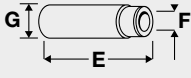

BP520, BP030



<b>12</b>	 <b>65.00</b>	<b>Petrol</b>					
146 A.048	4 Cyl.	9:1	903cc	33kW (45)PS	TD934	751	
							
	CG01A ▲					HR599 ■	

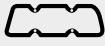

<b>13</b>	 <b>65.00</b>	<b>Petrol</b>				
146 A1.000	4 Cyl.	9:1	903cc	33kW (45)PS	TD4372	762







				
B x C x D	OE	MAT.		E x F x G
<b>V94576 ■</b>	46 407 749		45°	<b>VAG50895 ■ ■</b>
29.00 x 7.00 x 95.10		MB cr		46.00 x 7.04 x 13.03
<b>V91282 ■</b>	7 783 841		45°	<b>VAG92364 ■ ■</b>
26.00 x 7.00 x 95.50		MD		42.50 x 7.00 x 13.07
<b>V91766 ■</b>	7 783 861		45°	
26.00 x 7.00 x 95.50		MD		







							
BP520 Fibre Composite, 1.200mm BP030 Fibre Composite, 1.800mm	CG01A ▲ →Eng.8064870 DPO11 →Eng.8064870 DR610	GP011	HBS297 ⊕ M9x1.25x91.00mm (x9)	JC973 ■	JM333	HR599 ■	



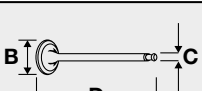



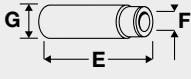

BP520, BP030

<b>14</b>	 <b>65.00</b>	<b>Petrol</b>				
170 A1.000	4 Cyl.	8.8:1	903cc	30kW (41)PS	TD15810	763

					
	.KIT		KIT		FOL119 (x8)

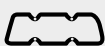
				
B x C x D	OE	MAT.		E x F x G
<b>V94576 ■</b>	46 407 749		45°	<b>VAG50895 ■ ■</b>
29.00 x 7.00 x 95.10		MB cr		46.00 x 7.04 x 13.03
<b>V91282 ■</b>	7 783 841		45°	<b>VAG92364 ■ ■</b>
26.00 x 7.00 x 95.50		MD		42.50 x 7.00 x 13.07

							
AY430 Fibre Composite BT260 Fibre Composite	DT260	GT260	HBS297 ⊕ M9x1.25x91.00mm (x9)	JC973 ■	JN803	HR599 ■	



AY430, BT260

<b>15</b>	<b>65.00</b>	<b>Petrol</b>				
170 A1.046	4 Cyl.	8.8:1	903cc	30kW (41)PS	TD15811	<b>763</b>

	OE	MAT.				
<b>V94576</b>	46 407 749		45°	H	<b>VAG50895</b>	
29.00 x 7.00 x 95.10		MB cr			46.00 x 7.04 x 13.03	
<b>V91282</b>	7 783 841		45°		<b>VAG92364</b>	
26.00 x 7.00 x 95.50		MD			42.50 x 7.00 x 13.07	

AY430 Fibre Composite	DT260	GT260	HBS297	JC973	JN803	HR599	
BT260 Fibre Composite			M9x1.25x91.00mm (x9)				



AY430, BT260













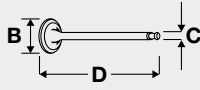

<b>16</b>	<b>65.00</b>	<b>Petrol</b>				
A112 A.000	4 Cyl.	9:1	903cc	21-32kW (29-44)PS	TD1856	<b>765</b>
A112 A5.000	4 Cyl.	9:1	903cc	29-31kW (40-42)PS	TD1803	<b>766</b>

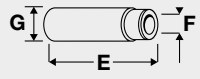







	OE	MAT.				
<b>V34457</b>	4 265 695		45°	H	<b>VAG92364</b>	
29.10 x 7.02 x 95.65		MB			42.50 x 7.00 x 13.07	
<b>V34654</b>	4 266 321		45°	H		
26.11 x 7.00 x 95.00		MG				



BP520 Fibre Composite, 1.200mm	DPO21	GP011			JN406		

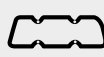

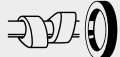





BP520











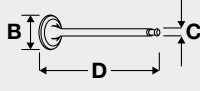

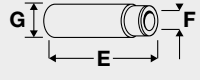

<b>17</b>	 <b>65.00</b>	<b>Petrol</b>						
<b>A112 B2.000</b>	4 Cyl.	9:1	903cc	<b>29-32kW (40-44)PS</b>	<b>TD4622</b>	<b>765</b>		
	$B \times C \times D$	OE	MAT.					$E \times F \times G$
<b>V34457</b> 	4 265 695		45°	H	<b>VAG92364</b>  			
29.10 x 7.02 x 95.65		MB			42.50 x 7.00 x 13.07			
<b>V91282</b> 	7 783 841		45°					
26.00 x 7.00 x 95.50		MD						











							
<b>BP520</b> Fibre Composite, 1.200mm	<b>DP021</b>	 <b>GP011</b>			<b>JN406</b>		
							
<b>BP520</b>							

<b>18</b>	 <b>67.20</b>	<b>Petrol</b>				
<b>A112 A2.000</b>	4 Cyl.	10.2:1	1050cc	<b>51kW (69)PS</b>	<b>TD4621</b>	<b>767</b>
					<b>JN406</b>	

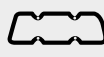
<b>19</b>	 <b>67.20</b>	<b>Petrol</b>				
<b>A112 B1.000</b>	4 Cyl.	9.2:1	965cc	<b>35kW (48)PS</b>	<b>TD1824</b>	<b>769</b>
						
		 <b>GP021</b>				

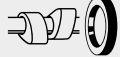
<b>20</b>	 <b>67.20</b>	<b>Petrol</b>				
<b>A 112 B1.054</b>	4 Cyl.	9.2:1	965cc	<b>35-36kW (48-49)PS</b>	<b>TD4412</b>	<b>770</b>

	$B \times C \times D$	OE	MAT.					$E \times F \times G$
<b>V34457</b> 	4 265 695		45°	H	<b>VAG50895</b>  			
29.10 x 7.02 x 95.65		MB			46.00 x 7.04 x 13.03			
<b>V91766</b> 	7 783 861		45°		<b>VAG92364</b>  			
26.00 x 7.00 x 95.50		MD			42.50 x 7.00 x 13.07			

							
<b>BP510</b> Fibre Composite, 1.200mm	<b>DP022</b>	 <b>GP022</b>		<b>JC973</b> 	<b>JM333</b>	<b>HR599</b> 	
<b>BP500</b> Fibre Composite, 1.800mm							
							
<b>BP510, BP500</b>							









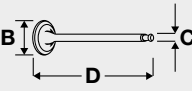

## 21



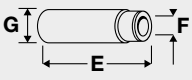







 67.40

**Petrol**



110 F.000	2 Cyl.	7.1:1	499cc	13kW (18)PS	TD871	772
120.000	2 Cyl.		499cc	13kW (18)PS	TD873	772

 B x C x D	OE	MAT.				 E x F x G
<b>V91739</b> 	4 294 098	 MB	45°		H	
32.00 x 8.00 x 115.00						
<b>V91633</b> 	4 146 638	 MD	45°			
28.00 x 8.00 x 115.80						
<b>V91712</b> 	4 374 855	 MD	45°			
28.00 x 8.00 x 116.10						

							
AM870 Fibre Composite	CM870	FM872		JA752  (x2) JA755  JE480  (x2)	JM490 JM674	KG393	



















AM870

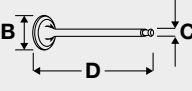



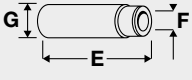





## 22

 69.60 **Diesel** 

169 A1.000	4 Cyl.	17.6:1	1248cc	55kW (75)PS	TD20236	773	
188 A9.000	4 Cyl.	18:1	1248cc	51-55kW (70-75)PS	Turbo Intercooled	TD17456	776
188 A9.000	4 Cyl.	18:1	1248cc	51kW (70)PS		TD18314	776
199 A2.000	4 Cyl.	18:1	1248cc	55-56kW (75-76)PS	Turbo Intercooled	TD20240	777

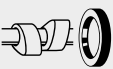
					
		CAM711  CAM712 			FOL187 (x16)

 B x C x D	OE	MAT.				 E x F x G
<b>V95015</b> 	55 195 680	 MB cr	45°	Y	H	
21.85 x 6.00 x 109.20						
<b>V95016</b> 	55 208 213	 MG cr	45°		H	
21.80 x 6.00 x 109.20						

							
AD5800 MLS, 0.720mm AD5810 MLS, 0.820mm, 1 Hole AD5820 MLS, 0.920mm, 2 Holes	CD5810 ▲	FD5810		HBS353  M10x1.25x119.00mm (x10)	JD5411  JD5413  MLS	JM5259 (Steel Elastomer)	HR5088 

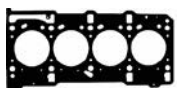









AD5800







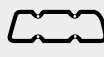

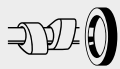







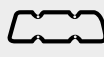

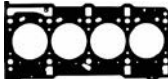
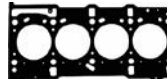





AD5810

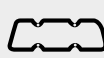

AD5820

<b>23</b>	 <b>69.60</b>	<b>Diesel</b>					
169 A5.000	4 Cyl.	16.8:1	1248cc	55kW (75)PS	Turbo Intercooled	TD24712	<b>774</b>
							
							NA5058 40.00x55.00x7.00mm FPM

<b>24</b>	 <b>69.60</b>	<b>Diesel</b>					
169 A5.000	4 Cyl.	16.8:1	1248cc	55kW (75)PS	Turbo Intercooled	TD24711	<b>775</b>
							
AD5800 MLS, 0.720mm AD5810 MLS, 0.820mm, 1 Hole AD5820 MLS, 0.920mm, 2 Holes				HBS353  M10x1.25x119.00mm (x10)	JM5259 (Steel Elastomer)		
AD5800	AD5810	AD5820					

<b>25</b>	 <b>69.60</b>	<b>Diesel</b>					
188 A8.000	4 Cyl.	18:1	1248cc	51kW (70)PS	Turbo Intercooled	TD23866	<b>776</b>
199 B2.000 Euro 5	4 Cyl.	17.6:1	1248cc	51kW (69)PS	Turbo Intercooled	TD23578	<b>780</b>
							
AD5800 MLS, 0.720mm AD5810 MLS, 0.820mm, 1 Hole AD5820 MLS, 0.920mm, 2 Holes	CD5810 ▲	FD5810	HBS353  M10x1.25x119.00mm (x10)	JD5411 ■ JD5413 ■ MLS	JM5259 (Steel Elastomer)	HR5088 ■	
AD5800	AD5810	AD5820					

# FIAT GROUP

<b>26</b>	<b>69.60</b>	<b>Diesel</b>	
<b>199 A2.000</b>	4 Cyl.	18:1	1248cc
			<b>55kW (75)PS</b>
			<b>Turbo Intercooled</b>
			<b>TD20272</b>
			<b>777</b>

	<b>.KIT</b>		<b>KIT</b>		
		<b>CAM711</b> ■			<b>FOL187</b> (x16)
		<b>CAM712</b> ■			

B x C x D	OE
<b>V95015</b> ■	<b>MAT.</b>
21.85 x 6.00 x 109.20	55 195 680
<b>V95016</b> ■	45°
21.80 x 6.00 x 109.20	55 208 213
	45°

<b>AD5800</b> MLS, 0.720mm	<b>CD5810</b> ▲	<b>FD5810</b>	<b>HBS353</b> ☒	<b>JD5411</b> ■	<b>JM5299</b> [5]	<b>HR5088</b> ■	
<b>AD5810</b> MLS, 0.820mm, 1 Hole			M10x1.25x119.00mm (x10)	<b>JD5413</b> ■			
<b>AD5820</b> MLS, 0.920mm, 2 Holes				MLS			

<b>AD5800</b>	<b>AD5810</b>	<b>AD5820</b>					
[5] Specification: Edge Moulded	[5] Spécification: bord moulé	[5] Specificazione: bordo modellato	[5] Especificación: borde moldeado				

<b>27</b>	<b>69.60</b>	<b>Diesel</b>	
<b>199 A3.000</b>	4 Cyl.	18:1	1248cc
			<b>66kW (90)PS</b>
			<b>Turbo Intercooled</b>
			<b>TD23450</b>
			<b>779</b>

	<b>.KIT</b>		<b>KIT</b>		
					<b>FOL187</b> (x16)

<b>AD5800</b> MLS, 0.720mm	<b>CD5820</b> ▲	<b>FD5820</b> ▲	<b>HBS353</b> ☒	<b>JD5993</b> ■	<b>JM5259</b>	<b>HR791</b> ■	
<b>AD5810</b> MLS, 0.820mm, 1 Hole			M10x1.25x119.00mm (x10)	<b>JD5413</b> ■	(Steel Elastomer)		
<b>AD5820</b> MLS, 0.920mm, 2 Holes				MLS			

## 28

### 69.60

### Diesel



199 A3.000      4 Cyl.      18:1      1248cc      66-70kW (90-95)PS      Turbo Intercooled      TD20241      778

CAM711 ■ CAM712 ■			FOL187 (x16)		

B x C x D	E x F x G
OE	MAT.
V95015 ■ 21.85 x 6.00 x 109.20	45° Y H
V95016 ■ 21.80 x 6.00 x 109.20	45° H

AD5800 MLS, 0.720mm	AD5810 MLS, 0.820mm, 1 Hole	AD5820 MLS, 0.920mm, 2 Holes	HBS353 ⊗ M10x1.25x119.00mm (x10)	JD5993 ■ JD5413 ■ MLS	JMS259 (Steel Elastomer)	HR791 ■
AD5800	AD5810	AD5820				

## 29

### 69.60

### Diesel





199 A3.000      4 Cyl.      18:1      1248cc      66-77kW (90-105)PS      Turbo Intercooled      TD20273      778



CAM711 ■ CAM712 ■			FOL187 (x16)		

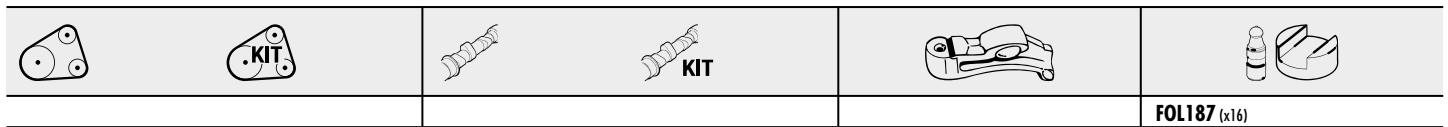

AD5800 MLS, 0.720mm	AD5810 MLS, 0.820mm, 1 Hole	AD5820 MLS, 0.920mm, 2 Holes	HBS353 ⊗ M10x1.25x119.00mm (x10)	JD5993 ■ JD5413 ■ MLS	JMS259 (Steel Elastomer)	HR791 ■
AD5800	AD5810	AD5820				

# FIAT GROUP



<b>30</b>	 <b>69.60</b>	<b>Diesel</b>					
<b>199 A9.000 Euro 5</b>	4 Cyl.	17.6:1	1248cc	<b>55kW (75)PS</b>	<b>Turbo Intercooled</b>	<b>TD23573</b>	<b>780</b>
<b>199 B1.000 Euro 5</b>	4 Cyl.	16.8:1	1248cc	<b>70kW (95)PS</b>	<b>Turbo Intercooled</b>	<b>TD23574</b>	<b>780</b>
<b>199 B1.000 Euro 5</b>	4 Cyl.	16.8:1	1248cc	<b>70kW (95)PS</b>	<b>Turbo Intercooled</b>	<b>TD24590</b>	<b>780</b>
<b>199 B1.000 Euro 5</b>	4 Cyl.	16.8:1	1248cc	<b>70kW (95)PS</b>	<b>Turbo Intercooled</b>	<b>TD24672</b>	<b>781</b>



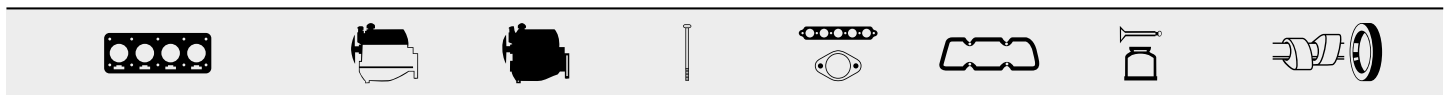

<b>AD5800</b> MLS, 0.720mm <b>AD5810</b> MLS, 0.820mm, 1 Hole <b>AD5820</b> MLS, 0.920mm, 2 Holes	<b>CD5810</b> ▲	<b>FD5810</b>	<b>HBS353</b> ☒ M10x1.25x119.00mm (x10)	<b>JD5411</b> ■ <b>JD5413</b> ■ MLS	<b>JM5259</b> (Steel Elastomer)	<b>HR5088</b> ■	
							
<b>AD5800</b>	<b>AD5810</b>	<b>AD5820</b>					

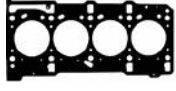

<b>31</b>	 <b>69.60</b>	<b>Diesel</b>					
<b>199 B4.000 Euro 5</b>	4 Cyl.	16.8:1	1248cc	<b>62kW (84)PS</b>	<b>Turbo Intercooled</b>	<b>TD24938</b>	<b>782</b>

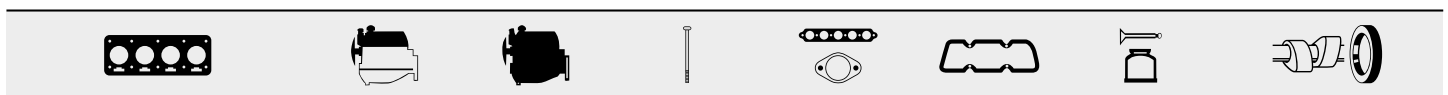
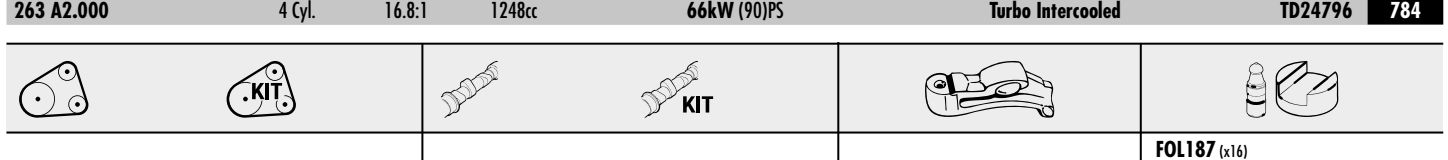

<b>AD5800</b> MLS, 0.720mm <b>AD5810</b> MLS, 0.820mm, 1 Hole <b>AD5820</b> MLS, 0.920mm, 2 Holes	<b>CD5820</b> ▲	<b>FD5820</b> ▲	<b>HBS353</b> ☒ M10x1.25x119.00mm (x10)	<b>JD5411</b> ■ <b>JD5413</b> ■ MLS	<b>JM5259</b> (Steel Elastomer)	<b>HR791</b> ■	
							
<b>AD5800</b>	<b>AD5810</b>	<b>AD5820</b>					

<b>32</b>	 <b>69.60</b>	<b>Diesel</b>					
<b>199 B4.000 Euro5/Euro6</b>	4 Cyl.	16.8:1	1248cc	<b>62kW (84)PS</b>	<b>Turbo Intercooled</b>	<b>TD24898</b>	<b>782</b>
<b>263 A2.000</b>	4 Cyl.	16.8:1	1248cc	<b>66kW (90)PS</b>	<b>Turbo Intercooled</b>	<b>TD24796</b>	<b>784</b>

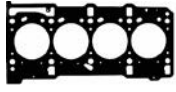

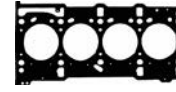
<b>AD5800</b> MLS, 0.720mm <b>AD5810</b> MLS, 0.820mm, 1 Hole <b>AD5820</b> MLS, 0.920mm, 2 Holes	<b>CD5820</b> ▲	<b>FD5820</b> ▲	<b>HBS353</b> ☒ M10x1.25x119.00mm (x10)	<b>JD5411</b> ■ <b>JD5413</b> ■ MLS	<b>JM5259</b> (Steel Elastomer)	<b>HR791</b> ■	
							
<b>AD5800</b>	<b>AD5810</b>	<b>AD5820</b>					



<b>33</b>	<b>69.60</b>	<b>Diesel</b>					
<b>223 A9.000</b>	4 Cyl.	17.6:1	1248cc	<b>62kW (84)PS</b>	<b>Turbo Intercooled</b>	<b>TD20243</b>	<b>783</b>
	<b>.KIT</b>		<b>KIT</b>				
		<b>CAM711</b>	<b>CAM712</b>			<b>FOL187</b> (x16)	

<b>AD5800</b> MLS, 0.720mm	<b>AD5810</b> MLS, 0.820mm, 1 Hole	<b>AD5820</b> MLS, 0.920mm, 2 Holes	<b>CD5820</b> ▲	<b>FD5820</b> ▲	<b>HBS353</b> M10x1.25x119.00mm (x10)	<b>JD5411</b> <b>JD5413</b> MLS	<b>JM5259</b> (Steel Elastomer)	<b>HR791</b>
<b>AD5800</b>	<b>AD5810</b>	<b>AD5820</b>						

<b>34</b>	<b>70.00</b>	<b>Petrol</b>				
<b>146 E1.011</b>	4 Cyl.	11.65:1	999cc	<b>47-56kW (64-76)PS</b>	<b>TD25023</b>	<b>792</b>
<b>178 B9.033</b>	4 Cyl.	9.6:1	1108cc	<b>40kW (54)PS</b>	<b>TD26111</b>	<b>788</b>
<b>178 D9.011</b>	4 Cyl.	10.8:1	999cc	<b>40-52kW (54-71)PS</b>	<b>TD25000</b>	

							<b>NA5053</b> 30.00x42.00x7.00mm FPM

<b>35</b>	<b>70.00</b>	<b>Petrol</b>				
<b>156 A2.000</b>	4 Cyl.	9.5:1	999cc	<b>33-37kW (45-50)PS</b>	<b>TD4592</b>	<b>793</b>
<b>156 A2.100</b>	4 Cyl.	9:1	999cc	<b>32kW (44)PS</b>	<b>TD4593</b>	<b>795</b>
<b>156 A2.246</b>	4 Cyl.	9.5:1	999cc	<b>33kW (45)PS</b>	<b>TD5423</b>	<b>785</b>
<b>156 C.000</b>	4 Cyl.	9:1	1108cc	<b>42kW (57)PS</b>	<b>TD1854</b>	<b>785</b>
<b>156 C.046</b>	4 Cyl.	9:1	1108cc	<b>37-40kW (50-54)PS</b>	<b>TD4597</b>	<b>785</b>

	<b>.KIT</b>		<b>KIT</b>				
<b>TB129</b> 104x15	<b>TBK006</b> Component No: TB129; AE1008TP						

<b>V91288</b> 30.50 x 7.00 x 97.00	7 666 228	<b>MB</b>	45°	<b>H</b>	<b>VAG50895</b> 46.00 x 7.04 x 13.03		
<b>V91289</b> 27.50 x 7.00 x 97.50	7 666 227	<b>MD</b>	45°		<b>VAG92364</b> 42.50 x 7.00 x 13.07		

<b>BP280</b> Fibre Composite, 1.650mm	<b>BV940</b> Fibre Composite, 2.000mm	<b>DV675</b>	<b>GP282</b>	<b>HBS052</b> M9x1.25x95.00mm (x10)	<b>JD148</b> <b>JD5375</b> <b>JF145</b> MLS	<b>JN667</b>	<b>HR599</b>
							<b>NA5053</b> 30.00x42.00x7.00mm FPM

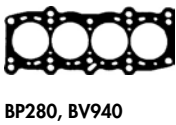



156 A2.048	4 Cyl.	9.2:1	999cc	32kW (44)PS	TD992	790
156 A2.100	4 Cyl.	9:1	999cc	32-33kW (44-45)PS	TD4387	793
156 A2.246	4 Cyl.	9.5:1	999cc	33kW (45)PS	TD994	785
156 A3.100	4 Cyl.	9.5:1	999cc	32-33kW (44-45)PS	TD4386	790
176 A6.000	4 Cyl.	9.6:1	1108cc	40kW (54)PS	TD1036	787

<b>TB129</b> 104x15 Eng.→9042883	<b>TBK006</b> Eng.→9042883 Component No: TB129; AE1008TP				<b>FOL126</b> (x8) [6]
<b>TB676</b> 125x15 Eng.9042884→	<b>TBK314</b> Eng.9042884→ Component No: TB676; AE1008TP				
[6] Mechanical	[6] Mécanique	[6] Meccanico	[6] Mecánico		

<b>V91288</b> ■ 30.50 x 7.00 x 97.00	7 666 228	MB	45°	H	<b>VAG50895</b> ■ ■ ■ 46.00 x 7.04 x 13.03
<b>V91289</b> ■ 27.50 x 7.00 x 97.50	7 666 227	MD	45°		<b>VAG92364</b> ■ ■ ■ 42.50 x 7.00 x 13.07

<b>BP280</b> Fibre Composite, 1.650mm <b>BV940</b> Fibre Composite, 2.000mm	<b>DV675</b>	<b>GP282</b>	<b>HBS052</b> ① M9x1.25x95.00mm (x10)	<b>JD148</b> ■ <b>JD5375</b> ■ ■ <b>JF145</b> MLS	<b>JN667</b>	<b>HR599</b> ■	<b>NA5053</b> 30.00x42.00x7.00mm FPM



BP280, BV940

## 37



### 70.00

### Petrol



<b>156 A3.000</b>	4 Cyl.	9.8:1	999cc	<b>37kW (50)PS</b>	<b>TD16209</b>	<b>793</b>
<b>156 C.046</b>	4 Cyl.	9.6:1	1108cc	<b>37-43kW (50-58)PS</b>	<b>TD4389</b>	<b>785</b>
<b>160 A3.000</b>	4 Cyl.	9.6:1	1108cc	<b>41-42kW (56-57)PS</b>	<b>TD10189</b>	<b>786</b>

<b>TB129</b> 104x15 Eng.→9042883	<b>TBK006</b> Eng.→9042883 Component No: TB129; AE1008TP				
<b>TB676</b> 125x15 Eng.9042884→	<b>TBK314</b> Eng.9042884→ Component No: TB676; AE1008TP				

<b>V91288</b> ■ 30.50 x 7.00 x 97.00	<b>V91289</b> ■ 27.50 x 7.00 x 97.50	<b>MAT.</b> MB MD	45° 45°	H	<b>VAG50895</b> ■ ■ 46.00 x 7.04 x 13.03	<b>VAG92364</b> ■ ■ 42.50 x 7.00 x 13.07

<b>BP280</b> Fibre Composite, 1.650mm <b>BV940</b> Fibre Composite, 2.000mm	<b>DV675</b>	<b>GP282</b>	<b>HBS052</b> ① M9x1.25x95.00mm (x10)	<b>JD148</b> ■ <b>JD5375</b> ■ <b>JF145</b> MLS	<b>JN667</b>	<b>HR599</b> ■	<b>NA5053</b> 30.00x42.00x7.00mm FPM



BP280, BV940



176 B2.000

4 Cyl.

9.6:1

1108cc

40kW (54)PS

TD4396

787

<b>TB129</b> 104x15 →11/96 <b>TB676</b> 125x15 12/96→, Eng.9042884→	<b>TBK006</b> →11/96 Component No: TB129; AE1008TP <b>TBK314</b> 12/96→ Eng.9042884→ Component No: TB676; AE1008TP		<b>KIT</b>		<b>FOL126 (x8) [6]</b>

[6] Mechanical

[6] Mécanique

[6] Meccanico

[6] Mecánico

<b>B x C x D</b>	<b>E x F x G</b>
<b>OE</b>	
<b>MAT.</b>	
<b>V91929</b> ■ 31.50 x 7.00 x 97.00	<b>VAG50895</b> ■ ■ ■ 46.00 x 7.04 x 13.03
<b>V91289</b> ■ 27.50 x 7.00 x 97.50	<b>VAG92364</b> ■ ■ ■ 42.50 x 7.00 x 13.07
<b>V94216</b> ■ 27.40 x 7.00 x 97.20	
7 770 334	
7 666 227	
46 514 754	
MB	
MD	
MD cr	
45°	
45°	
45° ss	
H	

<b>BP280</b> Fibre Composite, 1.650mm <b>BV940</b> Fibre Composite, 2.000mm	<b>DV675</b>	<b>GP282</b>	<b>HBS052</b> ① M9x1.25x95.00mm (x10)	<b>JD148</b> ■ <b>JD5375</b> ■ JF145 MLS	<b>JN667</b>	<b>HR599</b> ■	<b>NA5053</b> 30.00x42.00x7.00mm FPM



BP280, BV940

**39**

 **70.00**

**Petrol**



176 B2.000

4 Cyl.







9.6:1

1108cc

40kW (54)PS

TD11847

787









					
<b>TB129</b> 104x15 Eng.→9042883 <b>TB676</b> 125x15 Eng.9042884→	<b>TBK006</b> Eng.→9042883 Component No: TB129; AE1008TP <b>TBK314</b> Eng.9042884→ Component No: TB676; AE1008TP		<b>KIT</b>		<b>FOL126 (x8) [6]</b>

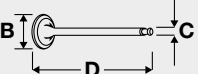



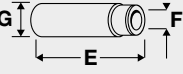

[6] Mechanical

[6] Mécanique

[6] Meccanico

[6] Mecánico

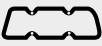
					
B x C x D	OE	MAT.			E x F x G
<b>V91929</b> ■ 31.50 x 7.00 x 97.00	7 770 334	 MB	45°	H	<b>VAG50895</b> ■ ■ ■ 46.00 x 7.04 x 13.03
<b>V91289</b> ■ 27.50 x 7.00 x 97.50	7 666 227	 MD	45°		<b>VAG92364</b> ■ ■ ■ 42.50 x 7.00 x 13.07
<b>V94216</b> ■ 27.40 x 7.00 x 97.20	46 514 754	 MD cr	45°	ss	

							
<b>BP280</b> Fibre Composite, 1.650mm <b>BV940</b> Fibre Composite, 2.000mm	<b>DV675</b>	<b>GP285</b>	<b>HBS052</b> ① M9x1.25x95.00mm (x10)	<b>JD148</b> ■ <b>JD5375</b> ■ <b>JF145</b> ■ MLS	<b>JN667</b>	<b>HR599</b> ■	<b>NA5053</b> 30.00x42.00x7.00mm FPM



BP280, BV940

187 A1.000

4 Cyl.

9.6:1

1108cc

40-42kW (54-57)PS

TD17847

**789**

<b>TB129</b> 104x15 Eng.→9042883 <b>TB676</b> 125x15 Eng.9042884→	<b>TBK006</b> Eng.→9042883 Component No: TB129; AE1008TP <b>TBK314</b> Eng.→9042884 Component No: TB676; AE1008TP				

	OE	MAT.			
B x C x D					E x F x G
<b>V91288</b>	7 666 228		45°	H	<b>VAG50895</b>
30.50 x 7.00 x 97.00 Eng.→2533527					46.00 x 7.04 x 13.03 Eng.→2533527
<b>V98020</b>	55 194 993		45°		<b>VAG92364</b>
31.90 x 5.00 x 98.40 Eng.2533528→					42.50 x 7.00 x 13.07 Eng.→2533527
<b>V91289</b>	7 666 227		45°		
27.50 x 7.00 x 97.50 Eng.→2533527					
<b>V98021</b>	55 194 994		45°		
27.30 x 5.00 x 98.70 Eng.2533528→					

<b>BP280</b> Fibre Composite, 1.650mm <b>BV940</b> Fibre Composite, 2.000mm	<b>DP286</b> →Eng.2543171	<b>GP282</b> <b>GP286</b>	<b>HBS052</b> M9x1.25x95.00mm (x10)	<b>JA5010</b> <b>JD5375</b> <b>JF145</b> MLS	<b>JM5019</b> (Elastomer)	<b>HR599</b>	<b>NA5053</b> 30.00x42.00x7.00mm FPM



BP280, BV940

<b>41</b>	<b>70.00</b>	<b>Petrol</b>				
<b>141 C2.000</b>	4 Cyl.	999cc	<b>31-33kW (42-45)PS</b>	<b>TD1070</b>	<b>790</b>	
<b>TB129</b> 104x15 Eng.→9042883 <b>TB676</b> 125x15 Eng.9042884→	<b>TBK006</b> Eng.→9042883 Component No: TB129; AE1008TP <b>TBK314</b> Eng.9042884→ Component No: TB676; AE1008TP		<b>KIT</b>		<b>FOL151 (x8) [6]</b>	

[6] Mechanical      [6] Mécanique      [6] Meccanico      [6] Mecánico

B x C x D	OE	MAT.	
<b>V91929</b> ■ 31.50 x 7.00 x 97.00	7 770 334	 MB	45°      H
<b>V91289</b> ■ 27.50 x 7.00 x 97.50	7 666 227	 MD	45°

<b>BP280</b> Fibre Composite, 1.650mm <b>BV940</b> Fibre Composite, 2.000mm	<b>DV675</b>	<b>GP282</b>	<b>HBS052</b> ⊕ M9x1.25x95.00mm (x10)	<b>JD148</b> ■ <b>JD5375</b> ■ <b>JF145</b> MLS	<b>JN667</b>	<b>HR599</b> ■	<b>NA5053</b> 30.00x42.00x7.00mm FPM



BP280, BV940

<b>42</b>	<b>70.00</b>	<b>Petrol</b>					
<b>146 B4.000</b>	4 Cyl.	9.8:1	999cc	<b>31-35kW (42-48)PS</b>	<b>TD18820</b>	<b>791</b>	
						<b>HR599</b> ■	

<b>43</b>	<b>70.00</b>	<b>Petrol</b>				
<b>156 A2.000</b>	4 Cyl.	9.5:1	999cc	<b>31-37kW (42-50)PS</b>	<b>TD16230</b>	<b>793</b>

<p>B x C x D</p>	OE	MAT.	<p>45°</p>	<p>H</p>	<p>E x F x G</p>
<b>V91288</b> ■	7 666 228		45°		<b>VAG50895</b> ■ ■
30.50 x 7.00 x 97.00					46.00 x 7.04 x 13.03
<b>V91289</b> ■	7 666 227		45°		<b>VAG92364</b> ■ ■
27.50 x 7.00 x 97.50					42.50 x 7.00 x 13.07

<b>BP280</b> Fibre Composite, 1.650mm <b>BV940</b> Fibre Composite, 2.000mm	<b>DV675</b>		<b>HBS052</b> ① M9x1.25x95.00mm (x10)	<b>JD148</b> ■ <b>JD5375</b> ■ ● <b>JF145</b> MLS	<b>JN667</b>	<b>HR599</b> ■	<b>NA5053</b> 30.00x42.00x7.00mm FPM

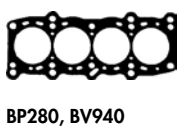

<b>44</b>	<b>70.00</b>	<b>Petrol</b>				
<b>156 A2.048</b>	4 Cyl.	9.2:1	999cc	<b>32kW (44)PS</b>	<b>TD1782</b>	<b>790</b>
<b>156 A2.146</b>	4 Cyl.	9.5:1	999cc	<b>33kW (45)PS</b>	<b>TD4594</b>	<b>790</b>
<b>156 A2.146</b>	4 Cyl.	9.5:1	999cc	<b>33kW (45)PS</b>	<b>TD993</b>	<b>790</b>

<b>BP280</b> Fibre Composite, 1.650mm <b>BV940</b> Fibre Composite, 2.000mm	<b>DV675</b>		<b>HBS052</b> ① M9x1.25x95.00mm (x10)	<b>JD148</b> ■ <b>JD5375</b> ■ ● <b>JF145</b> MLS	<b>JN667</b>	<b>HR599</b> ■	<b>NA5053</b> 30.00x42.00x7.00mm FPM

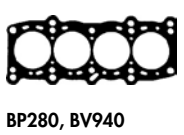



<b>45</b>	<b>70.80</b>	<b>Petrol</b>				
169 A4.000	4 Cyl.	11.1:1	1242cc	51kW (69)PS	TD20928	<b>797</b>
<b>TB787</b> 129x22						

B x C x D	E x F x G
OE	
MAT.	
<b>V98022</b>	45°
33.30 x 5.00 x 99.90	
<b>V98023</b>	45°
28.10 x 5.00 x 100.50	

AG7380 MLS	CG7380	HBS052	HA5053	JM7099 Soft Material Gasket	NA5058 40.00x55.00x7.00mm FPM
		M9x1.25x95.00mm (x10)	JD5375		



AG7380

<b>46</b>	<b>70.80</b>	<b>Petrol</b>				
169 A4.000	4 Cyl.	11.1:1	1242cc	49-51kW (67-69)PS	TD25192	<b>797</b>
AG7380 MLS	CG7380	HBS052	HA5053	JM7099 Soft Material Gasket	NA5058 40.00x55.00x7.00mm FPM	
		M9x1.25x95.00mm (x10)	JD5375			



AG7380

176 A7.000

4 Cyl.

9.6:1

1242cc

43-44kW (58-60)PS

TD1037

798

<b>TB660</b> 108x15 Eng.→9042883 <b>TB649</b> 129x15 Eng.9042884→	<b>TBK085</b> Eng.→9042883 Component No: TB660; AE1008TP <b>TBK277</b> Eng.9042884→ Component No: TB649; AE1008TP				

B x C x D OE MAT.  H	E x F x G  <b>V91288</b> ■ 30.50 x 7.00 x 97.00 <b>V91289</b> ■ 27.50 x 7.00 x 97.50 <b>VAG50895</b> ■ ■ 46.00 x 7.04 x 13.03 <b>VAG92364</b> ■ ■ ■ 42.50 x 7.00 x 13.07

<b>AE5240</b> MLS <b>BV670</b> Fibre Composite, 1.650mm <b>AE5550</b> Fibre Composite, 1.850mm	<b>DV675</b>	<b>HBS052</b> ① M9x1.25x95.00mm (x10)	<b>JD148</b> ■ <b>JD5375</b> ■ (x2) <b>JF145</b> MLS	<b>JN667</b>	<b>HR599</b> ■	<b>NA5053</b> 30.00x42.00x7.00mm FPM

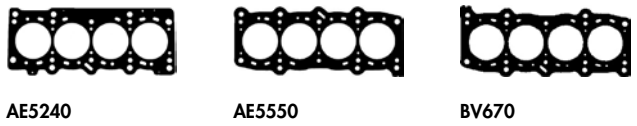

AE5240

AE5550

BV670

**48**

 **70.80**

**Petrol**



176 A8.000

4 Cyl.







9.8:1









1242cc

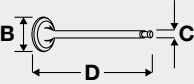

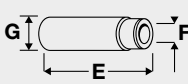

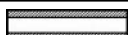





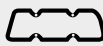

54kW (73)PS

TD1038

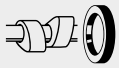
799

					
<b>TB660</b> 108x15 Eng.→9042883 <b>TB649</b> 129x15 Eng.9042884→	<b>TBK085</b> Eng.→9042883 Component No: TB660; AE1008TP <b>TBK277</b> Eng.9042884→ Component No: TB649; AE1008TP				

	OE	MAT.			
<b>V91929</b> 	7 770 334		45°	H	<b>VAG50895</b> 
31.50 x 7.00 x 97.00		MB			46.00 x 7.04 x 13.03
<b>V91289</b> 	7 666 227		45°		<b>VAG92364</b> 
27.50 x 7.00 x 97.50		MD			42.50 x 7.00 x 13.07

							
<b>AE5240</b> MLS <b>BV670</b> Fibre Composite, 1.650mm <b>AE5550</b> Fibre Composite, 1.850mm	<b>DV675</b>	<b>HBS052</b> 	M9x1.25x95.00mm (x10)	<b>JD150</b>  <b>JD5375</b>  <b>JF145</b>  MLS	<b>JN667</b>	<b>HR599</b> 	<b>NA5053</b> 30.00x42.00x7.00mm FPM



AE5240



AE5550



BV670



176 B1.000

4 Cyl.

10.2:1

1242cc

44kW (60)PS

TD1032

800

<b>TB660</b> 108x15 Eng.→9042883 <b>TB649</b> 129x15 Eng.9042884→	<b>TBK085</b> Eng.→9042883 Component No: TB660; AE1008TP <b>TBK277</b> Eng.9042884→ Component No: TB649; AE1008TP				<b>FOL126 (x8) [6]</b>

[6] Mechanical

[6] Mécanique

[6] Meccanico

[6] Mecánico

B x C x D OE MAT.  	E x F x G <b>VAG50895 [E]</b> 46.00 x 7.04 x 13.03 <b>VAG92364 [E]</b> 42.50 x 7.00 x 13.07
<b>V91929 [E]</b> 31.50 x 7.00 x 97.00 <b>V91289 [E]</b> 27.50 x 7.00 x 97.50	7 770 334 7 666 227 45° 45° H

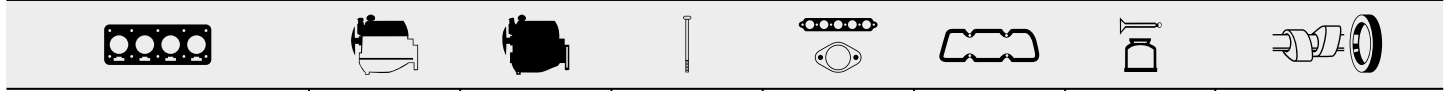

<b>AE5240</b> MLS <b>BV670</b> Fibre Composite, 1.650mm <b>AE5550</b> Fibre Composite, 1.850mm	<b>DV675</b>	<b>HBS052</b> M9x1.25x95.00mm (x10)	<b>JD150 [E]</b> <b>JD5375 [E]</b> <b>JF145</b> MLS	<b>JN667</b>	<b>HR599 [E]</b>	<b>NA5053</b> 30.00x42.00x7.00mm FPM
--	--------------	--	--	--------------	------------------	---



AE5240



AE5550



BV670

**50**

 **70.80**

**Petrol**



176 B4.000

4 Cyl.







9.8:1

1242cc

44kW (60)PS

TD1076

799







					
<b>TB660</b> 108x15 Eng.→9042883 <b>TB649</b> 129x15 Eng.9042884→	<b>TBK085</b> Eng.→9042883 Component No: TB660; AE1008TP <b>TBK277</b> Eng.9042884→ Component No: TB649; AE1008TP		<b>KIT</b>		<b>FOL126 (x8) [6]</b>



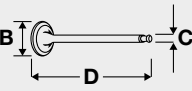

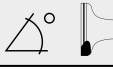

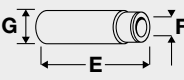

[6] Mechanical

[6] Mécanique

[6] Meccanico

[6] Mecánico

					
B x C x D	OE	MAT.	45°	H	E x F x G
<b>V91288</b> ■ 30.50 x 7.00 x 97.00	7 666 228		45°		<b>VAG50895</b> ■ ■ 46.00 x 7.04 x 13.03
<b>V91289</b> ■ 27.50 x 7.00 x 97.50	7 666 227		45°		<b>VAG92364</b> ■ ■ 42.50 x 7.00 x 13.07

							
<b>AE5240</b> MLS <b>BV670</b> Fibre Composite, 1.650mm <b>AE5550</b> Fibre Composite, 1.850mm	<b>DV675</b>	<b>HBS052</b> ⊕ M9x1.25x95.00mm (x10)	<b>JD150</b> ■ <b>JD5375</b> ■ <b>JF145</b> MLS	<b>JN667</b>	<b>HR599</b> ■	<b>NA5053</b> 30.00x42.00x7.00mm FPM	



AE5240

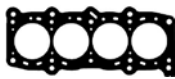

AE5550



BV670

# FIAT GROUP

**51**

**70.80**

**Petrol**



176 B9.000

4 Cyl.

10.2:1

1242cc

63kW (86)PS

TD11849

**802**

<b>TB637</b> 124x22 →07/00	<b>TBK313</b> →07/00 Component No: TB637; AE1101TP		<b>KIT</b>		<b>FOL168</b> (x16)

B x C x D	OE	MAT.	45°	H	E x F x G
<b>V94029</b> ■ 26.90 x 6.00 x 95.20	46 403 681		45°	H	<b>VAG96272</b> ■ ■ ■ 39.70 x 6.02 x 10.03
<b>V94030</b> ■ 22.50 x 6.00 x 96.20	46 471 639		45°		

<b>AD5830</b> MLS <b>BY380</b> Fibre Composite, 1.650mm	<b>DY382</b> →Eng.0616937 <b>CE5180</b> Eng.0616937→	<b>GY383</b> →Eng.0616937	<b>HBS247</b> ☒ M9x1.25x87.00mm (x10)	<b>JD464</b> ■ <b>JD465</b> ■ ○ <b>JF184</b>	<b>JM5176</b> [4]	<b>HR814</b> ■	<b>NA5058</b> 40.00x55.00x7.00mm FPM
<b>AD5830</b> [4] Specification: LEM	<b>BY380</b> [4] Spécification: LEM	[4] Specificazione: LEM	[4] Especificación: LEM				

**52**

**70.80**

**Petrol**



176 B9.000

4 Cyl.

10.2:1

1242cc

63kW (86)PS

TD9727

**801**

<b>TB637</b> 124x22	<b>TBK313</b> Component No: TB637; AE1101TP		<b>KIT</b>		<b>FOL123</b> (x16)

B x C x D	OE	MAT.	45°	H	E x F x G
<b>V94029</b> ■ 26.90 x 6.00 x 95.20	46 403 681		45°	H	<b>VAG96272</b> ■ ■ ■ 39.70 x 6.02 x 10.03
<b>V94030</b> ■ 22.50 x 6.00 x 96.20	46 471 639		45°		

<b>AD5830</b> MLS <b>BY380</b> Fibre Composite, 1.650mm	<b>DY382</b> →Eng.0616936 <b>CE5180</b> Eng.0616937→	<b>GY383</b> →Eng.0616937	<b>HBS247</b> ☒ M9x1.25x87.00mm (x10)	<b>JD464</b> ■ <b>JD465</b> ■ ○ <b>JF184</b>	<b>JM5176</b> [4]	<b>HR814</b> ■	<b>NA5058</b> 40.00x55.00x7.00mm FPM
<b>AD5830</b> [4] Specification: LEM	<b>BY380</b> [4] Spécification: LEM	[4] Specificazione: LEM	[4] Especificación: LEM				

## 53

### 70.80

#### Petrol



178 B5.000

4 Cyl.

9.8:1

1242cc

50-55kW (68-75)PS

TD10188

803

<b>TB660</b> 108x15 Eng.→9042883 <b>TB649</b> 129x15 Eng.9042884→	<b>TBK085</b> Eng.→9042883 Component No: TB660; AE1008TP <b>TBK277</b> Eng.9042884→ Component No: TB649; AE1008TP			<b>FOL126</b> (x8) [6]

[6] Mechanical

[6] Mécanique

[6] Meccanico

[6] Mecánico

<b>V94029</b> ■ 26.90 x 6.00 x 95.20 <b>V94030</b> ■ 22.50 x 6.00 x 96.20	46 403 681  46 471 639	MB MD cr	45° 45°	H	<b>VAG96272</b> ■ ■ ■ 39.70 x 6.02 x 10.03

<b>BV670</b> Fibre Composite, 1.650mm →08/03 <b>AE5550</b> Fibre Composite, 1.850mm →08/03 <b>AE5240</b> MLS 09/03→	<b>DV675</b>	<b>FE5240</b>	<b>HBS052</b> ⊕ M9x1.25x95.00mm (x10)	<b>JD150</b> ■ <b>JD5375</b> ■ (x2) <b>JF145</b> MLS	<b>JN667</b> →11/99 <b>JM5019</b> (Elastomer) 12/99→	<b>HR599</b> ■	<b>NA5053</b> 30.00x42.00x7.00mm FPM

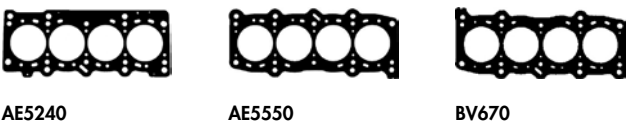

AE5240

AE5550

BV670

## 54

### 70.80

#### Petrol



178 B7.045

4 Cyl.

1242cc

44-60kW (60-82)PS

TD18895

804

<b>TB649</b> 129x15 Eng.→2533528 <b>TB787</b> 129x22 Eng.2533529→	<b>TBK277</b> Eng.→2533528 Component No: TB649; AE1008TP			

<b>BV670</b> Fibre Composite, 1.650mm →08/03 <b>AE5550</b> Fibre Composite, 1.850mm →08/03 <b>AE5240</b> MLS 09/03→	<b>DV675</b>	<b>FE5240</b>	<b>HBS052</b> ⊕ M9x1.25x95.00mm (x10)	<b>JD150</b> ■ <b>JD5375</b> ■ (x2) <b>JF145</b> MLS	<b>JN667</b> →11/99 <b>JM5019</b> (Elastomer) 12/99→06/02	<b>HR599</b> ■	<b>NA5053</b> 30.00x42.00x7.00mm FPM →Eng.2935743

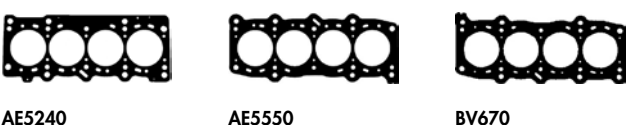

AE5240

AE5550

BV670

# FIAT GROUP

**55**

**70.80**

**Petrol**



178 C4.066

4 Cyl.

1242cc

44-46kW (60-63)PS

TD20237

**804**

<b>TB649</b> 129x15 Eng.→2533528	<b>TBK277</b> Eng.→2533528 Component No: TB649; AE1008TP				
<b>TB787</b> 129x22 Eng.2533529→					

<b>BV670</b> Fibre Composite, 1.650mm →08/03 <b>AE5550</b> Fibre Composite, 1.850mm →08/03 <b>AE5240</b> MLS 09/03→	<b>DV672</b> <b>DV675</b> <b>CE5242</b> Eng.2939661→	<b>FE5240</b>	<b>HBS052</b> Ⓢ M9x1.25x95.00mm (x10)	<b>JD150</b> ■ <b>JD5375</b> ■ (x2) <b>JF145</b> MLS	<b>JN667</b> →11/99 <b>JM5019</b> (Elastomer) 12/99→	<b>HR599</b> ■	<b>NA5053</b> 30.00x42.00x7.00mm FPM →Eng.2935743
<b>AE5240</b>	<b>AE5550</b>	<b>BV670</b>					

**56**

**70.80**

**Petrol**



178 E2.000

4 Cyl.

9.8:1

1242cc

50-54kW (68-73)PS

TD16737

**805**

<b>TB660</b> 108x15 Eng.→9042883	<b>TBK085</b> Eng.→9042883 Component No: TB660; AE1008TP				
<b>TB649</b> 129x15 Eng.9042884→	<b>TBK277</b> Eng.9042884→ Component No: TB649; AE1008TP				

B x C x D	E x F x G
<b>V91929</b> ■ 31.50 x 7.00 x 97.00	<b>VAG50895</b> ■ ■ 46.00 x 7.04 x 13.03
<b>V91289</b> ■ 27.50 x 7.00 x 97.50	<b>VAG92364</b> ■ ■ 42.50 x 7.00 x 13.07
7 770 334	
7 666 227	
<b>OE</b>	<b>MAT.</b>
<b>MD</b>	

<b>BV670</b> Fibre Composite, 1.650mm <b>AE5550</b> Fibre Composite, 1.850mm	<b>DV675</b>	<b>FE5240</b>	<b>HBS052</b> Ⓢ M9x1.25x95.00mm (x10)	<b>JD150</b> ■ <b>JD5375</b> ■ <b>JF145</b> MLS	<b>JN667</b> →11/99 <b>JM5019</b> (Elastomer) 12/99→06/02	<b>HR599</b> ■	<b>NA5053</b> 30.00x42.00x7.00mm FPM
<b>AE5550</b>	<b>BV670</b>						



**57**

**70.80**

**Petrol**



182 B2.000

4 Cyl.

1242cc

60-64kW (82-87)PS

TD11807

807

<b>TB637</b> 124x22	<b>TBK313</b> Component No: TB637; AE1101TP		<b>KIT</b>		

<b>B x C x D</b>	<b>E x F x G</b>
<b>V94029</b> ■ 26.90 x 6.00 x 95.20	<b>VAG96272</b> ■ ■ ■ 39.70 x 6.02 x 10.03
<b>V94030</b> ■ 22.50 x 6.00 x 96.20	

<b>BY380</b> Fibre Composite, 1.650mm →Eng.0616937	<b>DY382</b> →Eng.0616937	<b>GY383</b>	<b>HBS247</b> ☉ M9x1.25x87.00mm (x10)	<b>JD464</b> ■ <b>JD465</b> ■ <b>JF184</b> ■	<b>JM5176</b> [4]	<b>HR814</b> ■	<b>NA5058</b> 40.00x55.00x7.00mm FPM
<b>AD5830</b> MLS Eng.0616938 →	<b>CE5180</b> Eng.0616938 →						



**AD5830**  
[4] Specification: LEM

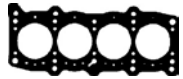

**BY380**  
[4] Spécification: LEM

[4] Specificazione: LEM

[4] Especificación: LEM

188 A4.000

4 Cyl.

9.5:1

1242cc

44kW (60)PS

TD12790

809

<b>TB649</b> 129x15 Eng.→2533528 <b>TB787</b> 129x22 Eng.2533529→	<b>TBK277</b> Eng.→2533528 Component No: TB649; AE1008TP		<b>KIT</b>		<b>FOL126 (x8) [6]</b>
[6] Mechanical	[6] Mécanique	[6] Meccanico	[6] Mecánico		

B x C x D	E x F x G
<b>V91929</b> ■ 31.50 x 7.00 x 97.00 Eng.→2533527	<b>VAG92364</b> ■ ■ 42.50 x 7.00 x 13.07
<b>V98020</b> ■ 31.90 x 5.00 x 98.40 Eng.2533528→	<b>VAG96273</b> ■ ■ 40.00 x 7.02 x 13.06
<b>V91289</b> ■ 27.50 x 7.00 x 97.50 Eng.→2533527	
<b>V98021</b> ■ 27.30 x 5.00 x 98.70 Eng.2533528→	
OE	MAT.
7 770 334	MB
55 194 993	MB cr
7 666 227	MD
55 194 994	MG cr
45°	45°
45°	45°
45°	45°
H	

<b>BV670</b> Fibre Composite, 1.650mm →08/03	<b>DV672</b> →Eng.1890665	<b>FE5240</b>	<b>HBS052</b> Ⓢ M9x1.25x95.00mm (x10)	<b>JA5010</b> ■ <b>JD5375</b> ■ <b>JF145</b> MLS	<b>JM5019</b> (Elastomer) →Eng.2939661 <b>JM7099</b> Soft Material Gasket Eng.2939662→	<b>HR800</b> ■	<b>NA5053</b> 30.00x42.00x7.00mm FPM →Eng.2939600
<b>AE5550</b> Fibre Composite, 1.850mm →08/03	<b>CE5241</b> Eng.2533528→ →Eng.2935742, 2939660						
<b>AE5240</b> MLS 09/03→	<b>CE5242</b> Eng.2939662→						

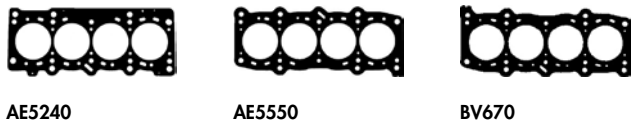

AE5240      AE5550      BV670

**59**

**70.80**

**Petrol**



188 A4.000

4 Cyl.

10.6:1

1242cc

44kW (60)PS

TD15501

808

<b>TB649</b> 129x15 Eng.→2533528 <b>TB787</b> 129x22 Eng.2533529→	<b>TBK277</b> Eng.→2533528 Component No: TB649; AE1008TP		<b>KIT</b>		<b>FOL126 (x8) [6]</b>

[6] Mechanical

[6] Mécanique

[6] Meccanico

[6] Mecánico

B x C x D	OE	MAT.
<b>V91929</b> ■■ 31.50 x 7.00 x 97.00 Eng.→2533527	7 770 334	 MB
<b>V98020</b> ■■ 31.90 x 5.00 x 98.40 Eng.2533528→	55 194 993	 MB cr
<b>V91289</b> ■■ 27.50 x 7.00 x 97.50 Eng.→2533527	7 666 227	 MD
<b>V98021</b> ■■ 27.30 x 5.00 x 98.70 Eng.2533528→	55 194 994	 MG cr
		45°
		H
		 <b>VAG92364</b> ■■ ■■ 42.50 x 7.00 x 13.07
		 <b>VAG96273</b> ■■ ■■ 40.00 x 7.02 x 13.06

<b>BV670</b> Fibre Composite, 1.650mm →08/03	<b>DV672</b> →Eng.1890665	<b>HBS052</b> ⊕ M9x1.25x95.00mm (x10)	<b>JA5010</b> ■■ <b>JD5375</b> ■■	<b>JM5019</b> (Elastomer) <b>JM7099</b> Soft Material Gasket Eng.2935743→	<b>HR599</b> ■■	<b>NA5053</b> 30.00x42.00x7.00mm FPM
<b>AE5550</b> Fibre Composite, 1.850mm →08/03	<b>CG7381</b> Eng.1890666→ →Eng.2533528					
<b>AE5240</b> MLS 09/03→	<b>CE5241</b> Eng.2533529→ →Eng.2939661					
	<b>CE5242</b> Eng.2939662→					



AE5240



AE5550



BV670

<b>TB637</b> 124x22	<b>TBK313</b> Component No: TB637; AE1101TP	<b>CAM713</b> ■ <b>CAM714</b> ■		<b>FOL168</b> (x16)

	OE	MAT.			
B x C x D					E x F x G
<b>V94029</b> ■ 26.90 x 6.00 x 95.20 Eng.→985540	46 403 681	 MB	45°	H	<b>VAG96272</b> ■ ■ ■ 39.70 x 6.02 x 10.03
<b>V98026</b> ■ 26.80 x 6.00 x 95.20 Eng.985541 →	55 185 028	 MB cr	45°		
<b>V94030</b> ■ 22.50 x 6.00 x 96.20 Eng.→985540	46 471 639	 MD cr	45°		
<b>V98027</b> ■ 22.50 x 6.00 x 94.70 Eng.985541 →	55 185 080	 ME cr	45°		

<b>AD5830</b> MLS →07/04 <b>BY380</b> Fibre Composite, 1.650mm →Eng.0616937 <b>AG7310</b> MLS 05/06 →	<b>DY383</b> →Eng.0616937 <b>CE5181</b> Eng.0616937 → <b>CG7310</b> 05/06 →	<b>GY383</b> →Eng.0616937	<b>HBS247</b> ☒ M9x1.25x87.00mm (x10)	<b>JA5005</b> ■ (Elastomer) <b>JA5006</b> ■	<b>JM5176</b> [4]	<b>HR814</b> ■	<b>NA5058</b> 40.00x55.00x7.00mm FPM



**AD5830**  
[4] Specification: LEM



**AG7310**  
[4] Spécification: LEM



**BY380**  
[4] Specificazione: LEM

[4] Especificación: LEM

61

 70.80

Petrol



188 A5.000 Euro 3 (D3)

4 Cyl.







10.6:1









1242cc

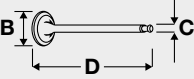



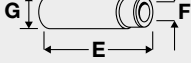

59kW (80)PS

TD15500

811

					
<b>TB637</b> 124x22	<b>TBK313</b> Component No: TB637; AE1101TP	<b>CAM713</b> ■ <b>CAM714</b> ■			<b>FOL168</b> (x16)

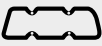
 B x C x D	OE	MAT.				 E x F x G
<b>V94029</b> ■ 26.90 x 6.00 x 95.20 Eng.→985540	46 403 681	 MB	45°		H	<b>VAG96272</b> ■ ■ ■ 39.70 x 6.02 x 10.03
<b>V98026</b> ■ 26.80 x 6.00 x 95.20 Eng.985541 →	55 185 028	 MB cr	45°			
<b>V94030</b> ■ 22.50 x 6.00 x 96.20 Eng.→985540	46 471 639	 MD cr	45°			
<b>V98027</b> ■ 22.50 x 6.00 x 94.70 Eng.985541 →	55 185 080	 ME cr	45°			

							
<b>BY380</b> Fibre Composite, 1.650mm →Eng.0616937 <b>AD5830</b> MLS Eng.0616937 →	<b>DY383</b> →Eng.0613937 <b>CE5181</b> Eng.0616937 →	<b>GY383</b> →Eng.0616937	<b>HBS247</b> Ⓢ M9x1.25x87.00mm (x10)	<b>JA5005</b> ■ (Elastomer) <b>JA5006</b> ■	<b>JM5176</b> [4]	<b>HR814</b> ■	<b>NA5058</b> 40.00x55.00x7.00mm FPM



**AD5830**  
[4] Specification: LEM



**BY380**  
[4] Spécification: LEM

[4] Specificazione: LEM

[4] Especificación: LEM

62

 70.80

Petrol



199 A4.000 Euro 4 (D4)

4 Cyl.

11:1

1242cc

48-51kW (65-69)PS

TD20242

797



TB787  
129x22

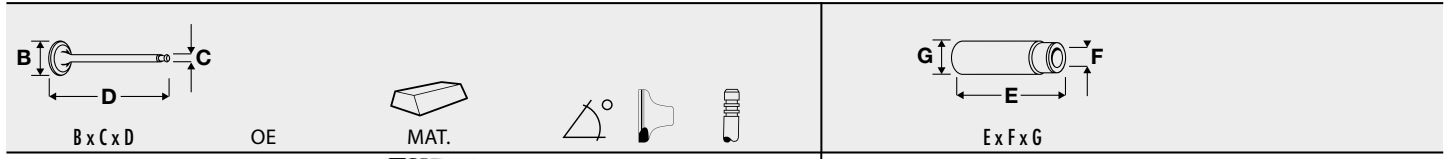

**V98022** 

33.30 x 5.00 x 99.90

55 194 219

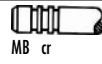

45°

**V98023** 

28.10 x 5.00 x 100.50

55 200 422

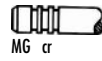

45°

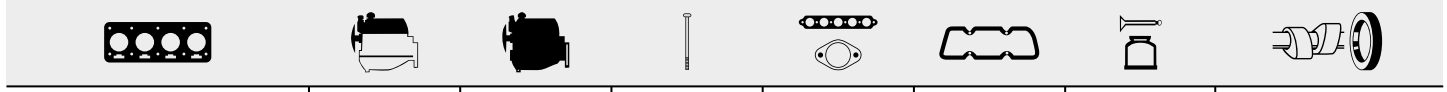



AE5240 MLS

AG7380 MLS

CE5242

HBS052 

M9x1.25x95.00mm (x10)

HA5053  

JD5375 

JM7099

Soft Material Gasket

NA5053

30.00x42.00x7.00mm FPM



AE5240



AG7380

**63**

**70.80**

**Petrol**



223 A5.000

4 Cyl.

9.8:1

1242cc

48kW (65)PS

TD15828

805

<b>TB649</b> 129x15 Eng.→2533528 <b>TB787</b> 129x22 Eng.2533529→	<b>TBK277</b> Eng.→2533528 Component No: TB649; AE1008TP		<b>KIT</b>		<b>FOL126 (x8) [6]</b>
[6] Mechanical	[6] Mécanique	[6] Meccanico	[6] Mecánico		

	OE	MAT.			
B x C x D			45°	H	E x F x G
<b>V91929</b> ■ 31.50 x 7.00 x 97.00 Eng.→2533527	7 770 334		45°	H	<b>VAG92364</b> ■ ■ 42.50 x 7.00 x 13.07
<b>V98020</b> ■ 31.90 x 5.00 x 98.40 Eng.2533528→	55 194 993		45°		<b>VAG96273</b> ■ ■ 40.00 x 7.02 x 13.06
<b>V91289</b> ■ 27.50 x 7.00 x 97.50 Eng.→2533527	7 666 227		45°		
<b>V98021</b> ■ 27.30 x 5.00 x 98.70 Eng.2533528→	55 194 994		45°		

<b>BV670</b> Fibre Composite, 1.650mm →08/03 <b>AE5550</b> Fibre Composite, 1.850mm →08/03 <b>AE5240</b> MLS 09/03→	<b>DV672</b> →08/03 <b>CE5241</b> Eng.2533528→ <b>CG7381</b> 09/03→ →Eng.2533527	<b>FE5240</b> 09/03→	<b>HBS052</b> Ⓢ M9x1.25x95.00mm (x10)	<b>JA5010</b> ■ <b>JD5375</b> ■ (x2)	<b>JM5019</b> (Elastomer)	<b>HR599</b> ■ →08/03	<b>NA5053</b> 30.00x42.00x7.00mm FPM
<b>AE5240</b>	<b>AE5550</b>	<b>BV670</b>					

# FIAT GROUP

<b>64</b>	<b>70.80</b>	<b>Petrol</b>				
<b>840 A3.000</b>	4 Cyl.	9.8:1	1242cc	<b>44kW (60)PS</b>	<b>TD1839</b>	<b>798</b>
<b>TB660</b> 108x15	<b>TBK085</b> Component No: TB660; AE1008TP		<b>KIT</b>			

B x C x D	E x F x G
<b>V91288</b> ■ 30.50 x 7.00 x 97.00	<b>VAG50895</b> ■ ■ 46.00 x 7.04 x 13.03
<b>V91289</b> ■ 27.50 x 7.00 x 97.50	<b>VAG92364</b> ■ ■ 42.50 x 7.00 x 13.07

<b>BV670</b> Fibre Composite, 1.650mm	<b>DV672</b>	<b>HB5052</b> Ⓢ M9x1.25x95.00mm (x10)	<b>JA5010</b> ■ <b>JD5375</b> ■	<b>JN667</b>	<b>HR599</b> ■	<b>NA5053</b> 30.00x42.00x7.00mm FPM
<b>AE5550</b>	<b>BV670</b>					

<b>65</b>	<b>72.00</b>	<b>Petrol</b>				
<b>169 A3.000</b>	4 Cyl.	1368cc	<b>74kW (100)PS</b>	<b>TD20277</b>	<b>813</b>	
<b>TB637</b> 124x22	<b>TBK313</b> Component No: TB637; AE1101TP		<b>KIT</b>			
<b>AG6220</b> MLS	<b>CG6220</b>	<b>HB5247</b> Ⓢ M9x1.25x87.00mm (x10)	<b>JA5006</b> ■	<b>JM5176</b> [4]	<b>NA5058</b> 40.00x55.00x7.00mm FPM	<b>NA5058</b> 40.00x55.00x7.00mm FPM

<b>AG6220</b>	[4] Specification: LEM	[4] Spécification: LEM	[4] Specificazione: LEM	[4] Especificación: LEM
---------------	------------------------	------------------------	-------------------------	-------------------------



<b>66</b>	<b>72.00</b>	<b>Petrol</b>			
<b>192 B2.000</b>	4 Cyl.	11:1	1368cc	<b>66kW (90)PS</b>	<b>TD18571 813</b>
<b>TB637</b> 124x22	<b>TBK313</b> Component No: TB637; AE1101TP		<b>KIT</b>		

B x C x D	OE	MAT.	Ex F x G
<b>V94029</b> ■■ 26.90 x 6.00 x 95.20 Eng.→984712	46 403 681	 MB	45° H
<b>V98026</b> ■■ 26.80 x 6.00 x 95.20 Eng.984713→	55 185 028	 MB cr	45°
<b>V94030</b> ■■ 22.50 x 6.00 x 96.20 Eng.→984712	46 471 639	 MD cr	45°
<b>V98027</b> ■■ 22.50 x 6.00 x 94.70 Eng.984713→	55 185 080	 ME cr	45°
			<b>VAG96272</b> ■■ ■■ 39.70 x 6.02 x 10.03



<b>AG6220</b> MLS →04/06	<b>CG6220</b> →04/06	<b>HBS247</b> Ⓢ M9x1.25x87.00mm (x10)	<b>HA5053</b> ■■ ■■ <b>JA5006</b> ■■	<b>JM5176</b> [4]	<b>NA5058</b> 40.00x55.00x7.00mm FPM
<b>AG7310</b> MLS 05/06→	<b>CG7310</b> 05/06→				









<b>AG6220</b> [4] Specification: LEM	<b>AG7310</b> [4] Spécification: LEM	[4] Specificazione: LEM	[4] Especificación: LEM

<b>67</b>	<b>72.00</b>	<b>Petrol</b>			
<b>192 B2.000</b>	4 Cyl.	11:1	1368cc	<b>66kW (90)PS</b>	<b>TD20952 813</b>
<b>AG6220</b> MLS →04/06	<b>CG6220</b> →04/06	<b>HBS247</b> Ⓢ M9x1.25x87.00mm (x10)	<b>HA5053</b> ■■ ■■ <b>JA5006</b> ■■	<b>JM5176</b> [4]	<b>NA5058</b> 40.00x55.00x7.00mm FPM
<b>AG7310</b> MLS 05/06→	<b>CG7310</b> 05/06→				

<b>AG6220</b> [4] Specification: LEM	<b>AG7310</b> [4] Spécification: LEM	[4] Specificazione: LEM	[4] Especificación: LEM

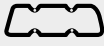

# FIAT GROUP







<b>68</b>		 <b>72.00</b>		<b>Petrol</b>				
198 A1.000	4 Cyl.	9.6:1	1368cc	110kW (150)PS	Turbocharged	TD21041	<b>816</b>	
198 A1.000	4 Cyl.		1368cc	110kW (150)PS	Turbocharged	TD23452	<b>815</b>	
198 A4.000	4 Cyl.	9.8:1	1368cc	88kW (120)PS	Turbo Intercooled	TD23921	<b>815</b>	
198 A7.000	4 Cyl.	9.8:1	1368cc	103kW (140)PS	Turbocharged	TD24595	<b>815</b>	
198 A7.000	4 Cyl.	9.8:1	1368cc	103kW (140)PS	Turbo Intercooled	TD24646	<b>816</b>	
198 A7.000	4 Cyl.	9.8:1	1368cc	103kW (140)PS	Turbo Intercooled	TD24650	<b>816</b>	
199 A8.000	4 Cyl.	9.8:1	1368cc	114-132kW (155-180)PS	Turbocharged	TD24567	<b>815</b>	
312 A3.000	4 Cyl.	9.8:1	1368cc	103-132kW (140-180)PS	Turbo Intercooled	TD24772	<b>822</b>	









							
AH6510 MLS			HBS247  M9x1.25x87.00mm (x10)		JM5176 [4]	HR814 	NA5058 40.00x55.00x7.00mm FPM



AH6510  
 [4] Specification: LEM      [4] Spécification: LEM      [4] Specificazione: LEM      [4] Especificación: LEM

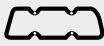

<b>69</b>		 <b>72.00</b>		<b>Petrol</b>				
198 A1.000	4 Cyl.	9.6:1	1368cc	110-112kW (150-152)PS	Turbocharged	TD21045	<b>815</b>	
198 A4.000	4 Cyl.	9.6:1	1368cc	88kW (120)PS	Turbocharged	TD21046	<b>815</b>	

					
TB637 124x22	TBK313 Component No: TB637; AE1101TP		KIT		







							
AH6510 MLS			HBS247  M9x1.25x87.00mm (x10)		JM5176 [4]	HR814 	NA5058 40.00x55.00x7.00mm FPM

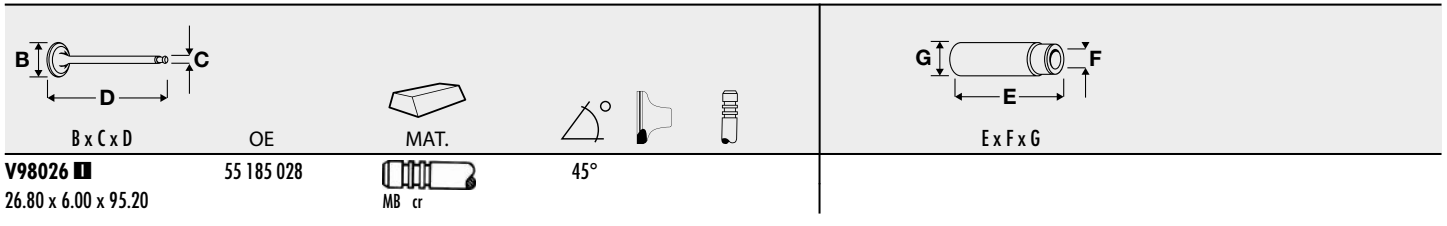

AH6510  
 [4] Specification: LEM      [4] Spécification: LEM      [4] Specificazione: LEM      [4] Especificación: LEM

<b>70</b>	 <b>72.00</b>	<b>Petrol</b>					
<b>198 A4.000</b>	4 Cyl.	9.6:1	1368cc	<b>88kW (120)PS</b>	<b>Turbocharged</b>	<b>TD21040</b>	<b>816</b>
<b>199 A8.000</b>	4 Cyl.		1368cc	<b>114kW (155)PS</b>	<b>Turbocharged</b>	<b>TD21700</b>	<b>815</b>

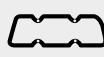









							
<b>AH6510</b> MLS			<b>HBS247</b> ☒		<b>JM5176</b> [4]	<b>HR814</b> ■	<b>NA5058</b>
			M9x1.25x87.00mm (x10)				40.00x55.00x7.00mm FPM



**AH6510**

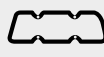

[4] Specification: LEM      [4] Spécification: LEM      [4] Specificazione: LEM      [4] Especificación: LEM







<b>71</b>	 <b>72.00</b>	<b>Petrol</b>				
<b>199 A1.000</b>	4 Cyl.		1368cc	<b>57kW (78)PS</b>	<b>TD25104</b>	<b>817</b>
<b>834 A1.000</b>	4 Cyl.	11:1	1368cc	<b>70kW (95)PS</b>	<b>TD23867</b>	<b>826</b>

							
<b>AG6220</b> MLS							

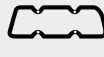

**AG6220**

<b>72</b>	 <b>72.00</b>	<b>Petrol</b>				
<b>199 A6.000</b>	4 Cyl.	11:1	1368cc	<b>70kW (95)PS</b>	<b>TD23447</b>	<b>818</b>

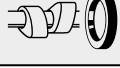
							
<b>AG7310</b> MLS			<b>HBS247</b> ☒		<b>JM5176</b> [4]	<b>HR814</b> ■	<b>NA5058</b>
			M9x1.25x87.00mm (x10)				40.00x55.00x7.00mm FPM



**AG7310**

[4] Specification: LEM      [4] Spécification: LEM      [4] Specificazione: LEM      [4] Especificación: LEM

# FIAT GROUP

<b>73</b>	<b>72.00</b>	<b>Petrol</b>				
<b>199 A6.000</b>	4 Cyl.	11:1	1368cc	<b>70-71kW (95-97)PS</b>	<b>TD20929</b>	<b>818</b>
<b>TB637</b> 124x22	<b>TBK313</b> Component No: TB637; AE1101TP		<b>KIT</b>			

B x C x D	E x F x G
<b>V98026</b>	<b>VAG96272</b>
26.80 x 6.00 x 95.20	39.70 x 6.02 x 10.03
<b>V98027</b>	
22.50 x 6.00 x 94.70	

<b>AG7310</b> MLS	<b>CG7380</b>	<b>HBS247</b>	<b>HA5053</b>	<b>JM5176</b> [4]	<b>HR814</b>	<b>NA5058</b>
		M9x1.25x87.00mm (x10)	<b>JD5375</b>			40.00x55.00x7.00mm FPM



**AG7310**  
[4] Specification: LEM      [4] Spécification: LEM      [4] Specificazione: LEM      [4] Especificación: LEM

<b>74</b>	<b>72.00</b>	<b>Petrol</b>				
<b>199 A7.000</b>	4 Cyl.	11:1	1368cc	<b>55kW (75)PS</b>	<b>TD23572</b>	<b>819</b>
<b>350 A1.000 Euro4/Euro5</b>	4 Cyl.	11.7:1	1368cc	<b>57kW (78)PS</b>	<b>TD26416</b>	<b>825</b>

<b>AG7380</b> MLS	<b>CG7380</b>	<b>HBS052</b>	<b>HA5053</b>	<b>JM7099</b>	<b>PA5025</b> (x8)	<b>NA5058</b>
		M9x1.25x95.00mm (x10)	<b>JD5375</b>	Soft Material Gasket		40.00x55.00x7.00mm FPM



**AG7380**

<b>75</b>	<b>72.00</b>	<b>Petrol</b>					
<b>312 A1.000</b>	4 Cyl.	9.8:1	1368cc	<b>99-140kW (135-190)PS</b>	<b>Turbo Intercooled</b>	<b>TD21036</b>	<b>821</b>

B x C x D	E x F x G
<b>V98026</b>	<b>VAG96272</b>
26.80 x 6.00 x 95.20	39.70 x 6.02 x 10.03

<b>AH6510</b> MLS	<b>CG7380</b>	<b>HBS247</b>	<b>HA5053</b>	<b>JM7099</b>	<b>PA5025</b> (x8)	<b>NA5058</b>
		M9x1.25x87.00mm (x10)	<b>JD5375</b>	Soft Material Gasket		40.00x55.00x7.00mm FPM















**AH6510**



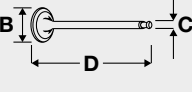

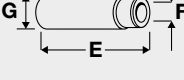

## 76

 **72.00**
**Petrol**

<b>350 A1.000</b>	4 Cyl.	11:1	1368cc	<b>55-57kW (75-78)PS</b>	<b>TD20274</b>	<b>825</b>
<b>350 A1.000 Euro4/Euro5</b>	4 Cyl.	11:1	1368cc	<b>51-57kW (69-78)PS</b>	<b>TD20248</b>	<b>825</b>

					
<b>TB787</b> 129x22					

					
B x C x D	OE	MAT.			E x F x G
<b>V98022</b> ■ 33.30 x 5.00 x 99.90	55 194 219	 MB cr	45°		
<b>V98023</b> ■ 28.10 x 5.00 x 100.50	55 200 422	 MG cr	45°		

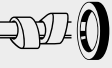
							
<b>AG7380</b> MLS	<b>CG7380</b>		<b>HBS052</b> ① M9x1.25x95.00mm (x10)	<b>HA5053</b> ■ ■ ■ <b>JD5375</b> ■	<b>JM7099</b> Soft Material Gasket	<b>PA5025</b> (x8)	<b>NA5058</b> 40.00x55.00x7.00mm FPM

**AG7380**

# FIAT GROUP

<b>77</b>	<b>72.00</b>	<b>Petrol</b>				
<b>843 A 1.000</b>	4 Cyl.	10.8:1	1368cc	<b>70kW (95)PS</b>	<b>TD17979</b>	<b>813</b>
<b>843 A1.000</b>	4 Cyl.	10.8:1	1368cc	<b>66-70kW (90-95)PS</b>	<b>TD17978</b>	<b>818</b>

<b>TB637</b> 124x22	<b>TBK313</b> Component No: TB637; AE1101TP				

B x C x D	E x F x G
<b>V94029</b> ■	<b>VAG96272</b> ■ ■
26.90 x 6.00 x 95.20 Eng.→984712	39.70 x 6.02 x 10.03
<b>V98026</b> ■	
26.80 x 6.00 x 95.20 Eng.984713→	
<b>V94030</b> ■	
22.50 x 6.00 x 96.20 Eng.→984712	
<b>V98027</b> ■	
22.50 x 6.00 x 94.70 Eng.984713→	

<b>AG6220</b> MLS →04/06	<b>CG6220</b> →04/06	<b>HBS247</b> ☒ M9x1.25x87.00mm (x10)	<b>JA5006</b> ■	<b>JM5176</b> [4]	<b>HR814</b> ■	<b>NA5058</b> 40.00x55.00x7.00mm FPM
<b>AG7310</b> MLS 05/06→	<b>CG7310</b> 05/06→					



**AG6220** [4] Specification: LEM  
**AG7310** [4] Spécification: LEM  
 [4] Specificazione: LEM  
 [4] Especificación: LEM



<b>78</b>	<b>72.00</b>	<b>Petrol</b>					
<b>940 A2.000 Euro 5</b>	4 Cyl.	9.8:1	1368cc	<b>125kW (170)PS</b>	<b>Turbo Intercooled</b>	<b>TD23920</b>	<b>820</b>
<b>955 A2.000 Euro 5</b>	4 Cyl.	9.8:1	1368cc	<b>99kW (135)PS</b>		<b>TD24588</b>	<b>821</b>
<b>955 A7.000</b>	4 Cyl.	9.8:1	1368cc	<b>99kW (135)PS</b>	<b>Turbocharged</b>	<b>TD24940</b>	<b>820</b>
<b>955 A8.000 Euro 5</b>	4 Cyl.	9.8:1	1368cc	<b>120kW (163)PS</b>	<b>Turbocharged</b>	<b>TD24589</b>	<b>820</b>









B x C x D	E x F x G
<b>V98026</b> ■	
26.80 x 6.00 x 95.20	

<b>AH6510</b> MLS	<b>HBS247</b> ☒ M9x1.25x87.00mm (x10)	<b>HR814</b> ■	<b>NA5321</b> 31.00x55.00x7.00mm FPM



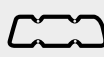

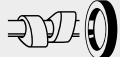
**AH6510**







<b>79</b>	 <b>72.00</b>	<b>Petrol</b>					
940 A6.000 Euro 5	4 Cyl.	9.8:1	1368cc	85kW (116)PS	Turbo Intercooled	TD24794	827
955 A1.000	4 Cyl.		1368cc	57-58kW (78-79)PS		TD23448	813
955 A2.000 Euro 5	4 Cyl.	9.8:1	1368cc	99kW (135)PS		TD23576	821
955 A6.000 Euro 5	4 Cyl.	10.8:1	1368cc	77kW (105)PS		TD23577	821
955 A8.000 Euro 5	4 Cyl.	9.8:1	1368cc	120-132kW (163-180)PS	Turbocharged	TD24767	820

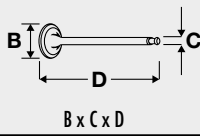

							
AH6510 MLS			HBS247  M9x1.25x87.00mm (x10)			HR814 	NA5321 31.00x55.00x7.00mm FPM



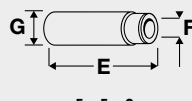







AH6510

<b>80</b>	 <b>72.00</b>	<b>Petrol</b>					
940 B1.000	4 Cyl.		1368cc	77kW (105)PS		TD26994	828

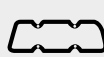

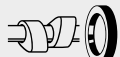
	OE				
B x C x D		MAT.	45°		E x F x G
V98026 	55 185 028				
26.80 x 6.00 x 95.20		MB cr			









<b>81</b>	 <b>72.00</b>	<b>Petrol</b>					
955 A6.000 Euro 5	4 Cyl.	10.8:1	1368cc	77kW (105)PS		TD24587	821

							
AG7310 MLS			HBS247  M9x1.25x87.00mm (x10)			HR814 	NA5321 31.00x55.00x7.00mm FPM

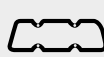

AG7310

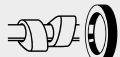
<b>82</b>	 <b>72.00</b>	<b>Petrol</b>					
955 A9.000	4 Cyl.	11.1:1	1368cc	51kW (69)PS		TD26417	829

							
AG7310 MLS			HBS247  M9x1.25x87.00mm (x10)				NA5321 31.00x55.00x7.00mm FPM



AG7310

<b>83</b>	<b>73.50</b>	<b>Petrol</b>				
<b>126 A.000</b>	2 Cyl.	7.5:1	594cc	<b>17kW (23)PS</b>	<b>TD880</b>	<b>831</b>

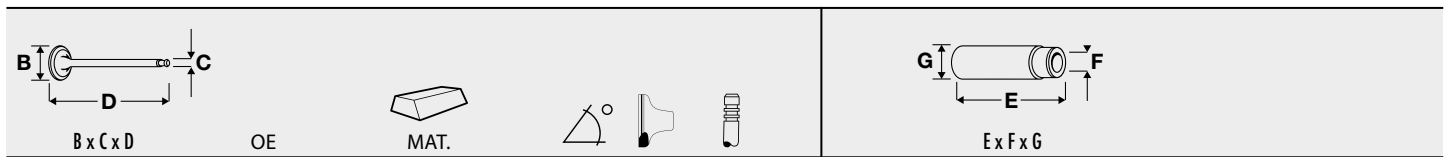

<b>V91739</b>	4 294 098					
32.00 x 8.00 x 115.00		MB				

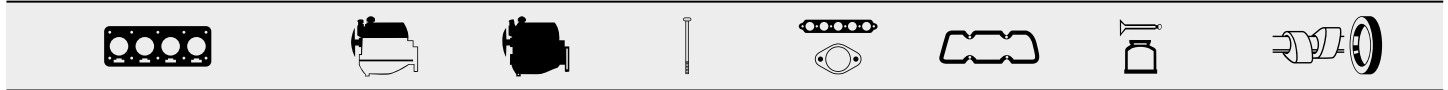

<b>BD800</b> Fibre Composite, 1.800mm	<b>CN400</b>	<b>FN402</b>		<b>JA752</b>	<b>JM490</b> <b>JM674</b>	<b>KG393</b>
				<b>JE480</b> (x2)		



**BD800**

<b>84</b>	<b>74.00</b>	<b>Petrol</b>			
<b>AR 00530</b>	4 Cyl.	1290cc	<b>64-65kW (87-89)PS</b>	<b>TD23</b>	<b>835</b>

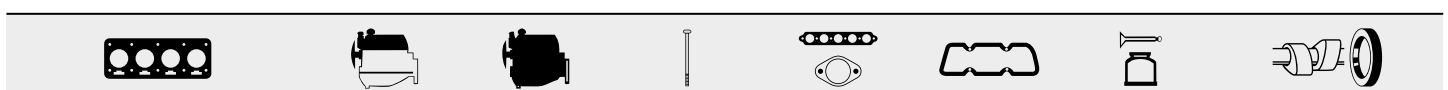

<b>AF240</b> Fibre Composite		<b>FF24R</b>		<b>JA829</b>		
------------------------------	--	--------------	--	--------------	--	--



**AF240**

[1] Without crankshaft seal      [1] sans bague d'étanchéité - vilebrequin      [1] senza paraolio-albero a gomiti      [1] sin cigüeñal retén

<b>85</b>	<b>75.00</b>	<b>Petrol</b>				
<b>KFT</b>	4 Cyl.	10.2:1	1360cc	<b>54kW (73)PS</b>	<b>TD24950</b>	<b>837</b>
<b>KFV</b>	4 Cyl.	10.5:1	1360cc	<b>54kW (73)PS</b>	<b>TD24771</b>	<b>837</b>

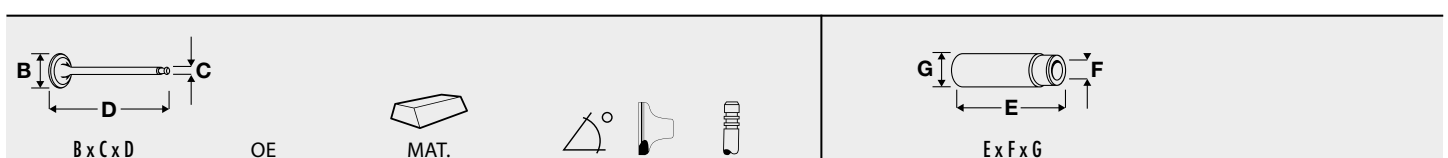

<b>V91271</b>	97 533 266			<b>VAG92401</b>	
37.00 x 7.00 x 112.50		MB		47.50 x 7.01 x 13.06	
<b>V91273</b>	97 533 264			<b>VAG96132</b>	
29.50 x 7.00 x 112.50		MD cr		47.60 x 7.03 x 13.11	

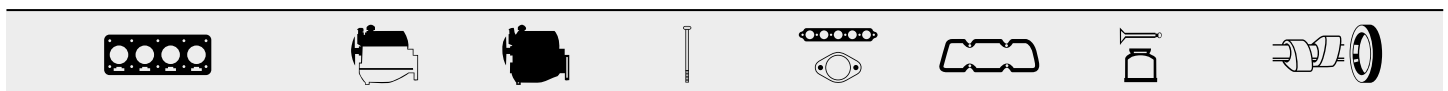















<b>AD5701</b> Fibre Composite, 1.250mm			<b>HB5039</b>	<b>JN658</b>	<b>NF817</b>
			M10x1.50x175.00mm (x10)		36.00x50.00x7.00mm FPM



**AD5701**





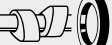

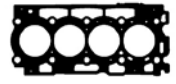









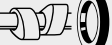

<b>86</b>	 <b>75.00</b>	<b>Diesel</b>					
<b>9HU</b>	4 Cyl.	18:1	1560cc	<b>66kW (90)PS</b>	<b>Turbo Intercooled</b>	<b>TD24776</b>	<b>838</b>
							
<b>TB724</b> 137x25.4							

							
<b>AD5130</b> MLS, 1.250mm, 2 Notches <b>AD5140</b> MLS, 1.300mm, 3 Notches <b>AD5150</b> MLS, 1.350mm, 1 Notch <b>AD5160</b> MLS, 1.400mm, 4 Notches <b>AD5170</b> MLS, 1.450mm, 5 Notches	<b>CD5140</b> ▲		<b>HBS359</b> ☺ M11x1.50x147.00mm (x10)	<b>HA5031</b> ■ ☒ ■ ■ <b>HA5030</b> ■ ■ ■ ■ ■ <b>JD5829</b> ■ ■	<b>JM7034</b> (Elastomer)		<b>NA5258</b> 27.00x47.00x7.00mm PTFE







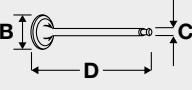
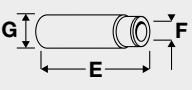

AD5130, AD5140, AD5150, AD5160, AD5170

<b>87</b>	 <b>75.40</b>	<b>Petrol</b>					
<b>178 E5.022</b>	4 Cyl.		1461cc	<b>62kW (84)PS</b>		<b>TD20448</b>	
							
						<b>HR599</b> ■	<b>NB866</b> 28.00x42.00x7.00mm FPM

<b>88</b>	 <b>76.00</b>	<b>Petrol</b>					
<b>127 A.000</b>	4 Cyl.		1049cc	<b>37-41kW (50-56)PS</b>		<b>TD887</b>	<b>839</b>
							
<b>TB121</b> 117x15							

	
B x C x D	E x F x G
<b>V90064</b> ■ 34.00 x 8.00 x 110.00	<b>JC973</b> ■
<b>V90399</b> ■ 29.10 x 7.99 x 110.50	
OE: 4 340 118	
OE: 4 340 119	
MAT. MB	
MAT. MD	
45°	
45°	
H	

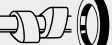
							
<b>BPO60</b> Fibre Composite, 1.200mm			<b>HBS279</b> ▲ M11x1.50x154.00mm (x6)	<b>JC973</b> ■	<b>JM333</b> <b>JN283</b>	<b>HR599</b> ■	

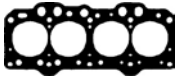

BPO60

# FIAT GROUP

89

 76.00

Petrol



127 A1.000

4 Cyl.

1049cc

51kW (70)PS

TD4345

840



TB121  
117x15

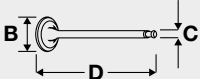

B x C x D

OE



MAT.



45°



H

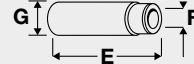

E x F x G

V90064 ■  
34.00 x 8.00 x 110.00

4 340 118

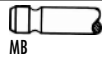

MB

45°

H

V90398 ■  
36.60 x 7.98 x 110.50

4 412 816

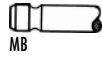

MB

45°

H

V90399 ■  
29.10 x 7.99 x 110.50

4 340 119

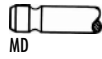

MD

45°

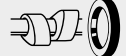
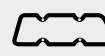

JN283

90

 76.00

Petrol



127 A6.000

4 Cyl.

1049cc

44kW (60)PS

TD4347

840



TB114  
116x19  
→02/79  
TB121  
117x15  
02/79→

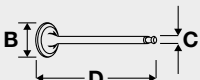

B x C x D

OE



MAT.



45°



H

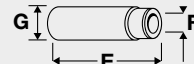

E x F x G

V90064 ■  
34.00 x 8.00 x 110.00

4 340 118

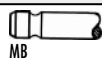

MB

45°

H

V90398 ■  
36.60 x 7.98 x 110.50

4 412 816

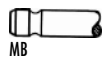

MB

45°

H

V90399 ■  
29.10 x 7.99 x 110.50

4 340 119

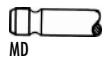





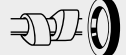
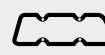

















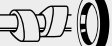

MD









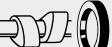









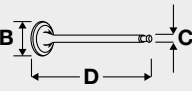

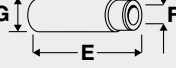

45°



JN283

<b>91</b>	 <b>76.00</b>	<b>Petrol</b>					
<b>156 A1.000</b>	4 Cyl.	7:1	1049cc	<b>62kW (84)PS</b>	<b>Turbo Intercooled</b>	<b>TD1783</b>	<b>841</b>
							
<b>TB248</b> 118x15							
							
<b>BP290</b>							

<b>92</b>	 <b>76.00</b>	<b>Petrol</b>					
<b>131 A6.000</b>	4 Cyl.		1297cc	<b>40kW (54)PS</b>		<b>TD897</b>	<b>843</b>
							
						<b>HR596</b>	

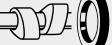
<b>93</b>	 <b>76.00</b>	<b>Petrol</b>					
<b>146 A 5.046</b>	4 Cyl.	9:1	1297cc	<b>53kW (72)PS</b>		<b>TD4591</b>	<b>841</b>
							
<b>TB247</b> 120x15 →08/95							
	<b>OE</b>	<b>MAT.</b>					
<b>V90398</b> 	4 412 816		45°	H	<b>VAG92369</b> 		
36.60 x 7.98 x 110.50					60.00 x 8.00 x 13.07		
<b>V90399</b> 	4 340 119		45°				
29.10 x 7.99 x 110.50							
							
<b>BP290</b>							

146 B1.000

4 Cyl.

1301cc

33kW (45)PS

TD948

845



KIT



**TB143**  
133x22  
04/84 →

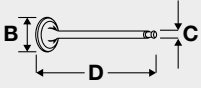

B x C x D

OE



MAT.



45°



H

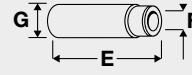

E x F x G

**V91652** ■

34.00 x 8.00 x 112.00



MB

**V91763** ■

34.00 x 8.00 x 112.00

4 424 173



MB

**V91653** ■

29.00 x 8.00 x 112.00

4 424 174



MD

**V91764** ■

29.00 x 8.00 x 112.00

4 424 174



ME cr

45°

ss

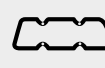
**BJ860** Fibre Composite, 1.650mm**BJ870** Fibre Composite, 1.800mm, 1 Notch**BJ880** Fibre Composite, 1.950mm, 2 Notches**DJ872** ▲**GJ872** ▲**JD5155** (x2)**JN669**

(Cork)

**HR596** ■**BJ860, BJ870, BJ880**

**95**

 **76.00**

**Diesel**



127 A5.000

4 Cyl.







20:1









1302cc

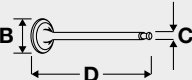



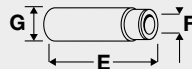

33kW (45)PS

TD4346

846

					
<b>TB577</b> 133x19 Eng.→35570 <b>TB143</b> 133x22 Eng.35571→		<b>CAM391</b>		<b>FOL104 (x8) [6]</b>	
[6] Mechanical		[6] Mécanique		[6] Meccanico	

	OE				
B x C x D		MAT.	45°	H	E x F x G
<b>V91652</b> ■			45°		
34.00 x 8.00 x 112.00		MB			
<b>V91763</b> ■	4 424 173		45°	H	
34.00 x 8.00 x 112.00		MB			
<b>V91653</b> ■	4 424 174		45°		
29.00 x 8.00 x 112.00		MD			
<b>V91764</b> ■	4 424 174		45°	ss	
29.00 x 8.00 x 112.00		ME cr			

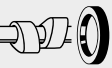
							
<b>BJ860</b> Fibre Composite, 1.650mm <b>BJ870</b> Fibre Composite, 1.800mm, 1 Notch <b>BJ880</b> Fibre Composite, 1.950mm, 2 Notches	<b>DJ872</b> ▲	<b>GJ872</b> ▲	<b>JD5155</b> (x2)	<b>JN669</b> (cork)	<b>HR596</b> ■	<b>NA5187</b> 30.00x52.00x7.00mm ACM	



BJ860, BJ870, BJ880

# FIAT GROUP

<b>96</b>	<b>76.00</b>	<b>Diesel</b>	
<b>156 A5.000</b>	4 Cyl.	20:1	1302cc
			<b>27kW (37)PS</b>
			<b>TD999 845</b>

<b>TB143</b> 133x22 →04/91		<b>CAM391</b>		<b>FOL104 (x8) [6]</b>
[6] Mechanical	[6] Mécanique	[6] Meccanico	[6] Mecánico	

<b>V91652</b> ■				45°		
34.00 x 8.00 x 112.00			MB		H	
<b>V91763</b> ■	4 424 173		MB	45°		
34.00 x 8.00 x 112.00			MD	45°		
<b>V91653</b> ■	4 424 174		ME cr	45°	ss	
29.00 x 8.00 x 112.00						
<b>V91764</b> ■	4 424 174					
29.00 x 8.00 x 112.00						



















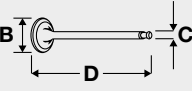
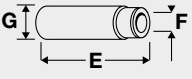







<b>BJ860</b> Fibre Composite, 1.650mm	<b>DJ872</b> ▲	<b>GJ872</b> ▲	<b>JD5155</b> (x2)	<b>JN669</b> (Cork)	<b>HR596</b> ■	<b>NA5187</b> 30.00x52.00x7.00mm ACM
<b>BJ870</b> Fibre Composite, 1.800mm, 1 Notch						
<b>BJ880</b> Fibre Composite, 1.950mm, 2 Notches						



















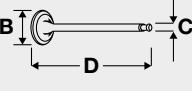
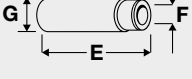



























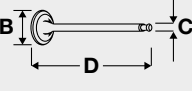
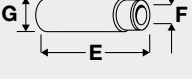





BJ860, BJ870, BJ880

<b>97</b>	<b>76.00</b>	<b>Petrol</b>	
<b>146 A2.166</b>	4 Cyl.	994cc	<b>35kW (48)PS</b>
			<b>TD19059 847</b>

<b>HBS052</b> ① M9x1.25x95.00mm (x10)	<b>HR599</b> ■	<b>NA5053</b> 30.00x42.00x7.00mm FPM

<b>98</b>	 <b>76.10</b>	<b>Petrol</b>					
<b>156 A.000</b>	4 Cyl.	9.5:1	1049cc	<b>40-41kW (54-56)PS</b>	<b>TD4411</b>	<b>848</b>	
							
<b>TB248</b> 118x15							
							
<b>B x C x D</b>	<b>OE</b>	<b>MAT.</b>			<b>Ex F x G</b>		
<b>V90398</b>  36.60 x 7.98 x 110.50	4 412 816		45°	H			
<b>V90399</b>  29.10 x 7.99 x 110.50	4 340 119		45°				
							
						<b>HR569</b> 	<b>HR596</b> 

<b>99</b>	 <b>76.10</b>	<b>Petrol</b>					
<b>156 A.000</b>	4 Cyl.	9.5:1	1049cc	<b>40-41kW (54-56)PS</b>	<b>TD21222</b>	<b>848</b>	
							
<b>TB121</b> 117x15 →09/87							
							
<b>B x C x D</b>	<b>OE</b>	<b>MAT.</b>			<b>Ex F x G</b>		
<b>V90398</b>  36.60 x 7.98 x 110.50	4 412 816		45°	H			
<b>V90399</b>  29.10 x 7.99 x 110.50	4 340 119		45°				
							
						<b>HR805</b> 	

<b>100</b>	 <b>76.10</b>	<b>Petrol</b>					
<b>127 A3.000</b>	4 Cyl.		1301cc	<b>55kW (75)PS</b>	<b>TD4415</b>	<b>844</b>	
							
<b>TB388</b> 121x15 →12/82 Length:1152.5mm Groove Distance: 9.525							
<b>TB247</b> 120x15							
							
<b>B x C x D</b>	<b>OE</b>	<b>MAT.</b>			<b>Ex F x G</b>		
<b>V90398</b>  36.60 x 7.98 x 110.50	4 412 816		45°	H			
<b>V90399</b>  29.10 x 7.99 x 110.50	4 340 119		45°				
							
				<b>JD5155 (x2)</b>	<b>JN283</b>		

# FIAT GROUP

## 101

### 76.10

#### Petrol



156 B.000      4 Cyl.      9.5:1      1301cc      53-56kW (72-76)PS      TD1853      849



**TB247**  
120x15  
→08/95

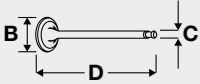

B x C x D

OE



MAT.



45°

H

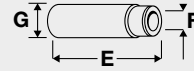

E x F x G

<b>V90064</b> ■	4 340 118		45°	H
34.00 x 8.00 x 110.00		MB		
<b>V90398</b> ■	4 412 816		45°	H
36.60 x 7.98 x 110.50		MB		
<b>V90399</b> ■	4 340 119		45°	
29.10 x 7.99 x 110.50		MD		

<b>VAG92369</b> ■ ■ ■	
60.00 x 8.00 x 13.07	

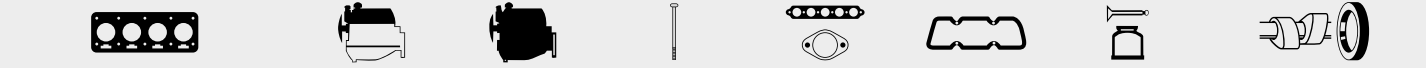

BP290 Fibre Composite      DP292      JD5155 (x2)



BP290

## 102

### 77.00

#### Petrol



126 A1.000      2 Cyl.      652cc      17kW (23)PS      TD4343      850  
126 A1.048      2 Cyl.      7.5:1      652cc      17-20kW (23-27)PS      TD881      850

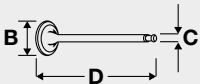

B x C x D

OE



MAT.



45°

H



E x F x G

<b>V91739</b> ■	4 294 098		45°	H
32.00 x 8.00 x 115.00		MB		
<b>V91712</b> ■	4 374 855		45°	
28.00 x 8.00 x 116.10		MD		

--	--

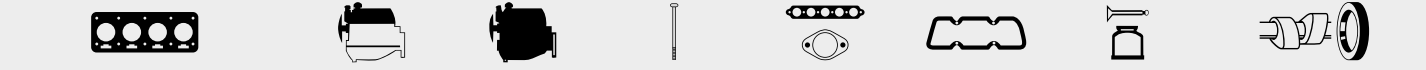

BD790 Fibre Composite, 1.200mm      DD790      GD671      GD790 [1]      JC723 ■      JA752 ■ (x2)      JE480 (x2)      JM674      KG393



BD790

[1] Without crankshaft seal

[1] sans bague d'étanchéité - vilebrequin

[1] senza paraolio-albero a gomiti

[1] sin cigüeñal retén



103		77.00		Petrol		141 A.000		2 Cyl.		8:1		652cc		22kW (30)PS		TD9385		851						
<b>V91712</b> 28.00 x 8.00 x 116.10					OE 4 374 855					MAT. 45° MD					Ex F x G									
<b>BPO50</b> Fibre Composite <b>BPO30</b> Fibre Composite, 1.800mm					<b>DP051</b> <b>DR611</b> Eng.8061128→ <b>DS570</b> Eng.8061128→					<b>GP051</b> <b>GR611</b>					<b>JA752</b> (x2) <b>JC973</b>					<b>JM674</b> <b>KG393</b> <b>HR596</b>				
<b>BPO30</b>					<b>BPO50</b>																			

104		78.00		Petrol		131 C.000		4 Cyl.		1367cc		51kW (70)PS		TD902		852			
<b>V91765</b> 43.50 x 8.00 x 105.00					OE 7 547 400					MAT. 45° H					Ex F x G				
															<b>NA5187</b> 30.00x52.00x7.00mm ACM				

105		78.00		Petrol		131 C1.000		4 Cyl.		1367cc		51-55kW (69-75)PS		TD903		852			
<b>V91765</b> 43.50 x 8.00 x 105.00					OE 7 547 400					MAT. 45° H									
<b>V91305</b> 36.50 x 8.00 x 106.00					OE 7 597 080					MAT. 45° MD cr									
<b>V91394</b> 36.50 x 8.00 x 105.50					OE 5 953 041					MAT. 45° MD					ss				
<b>V91636</b> 36.50 x 8.00 x 106.00					OE 5 975 341					MAT. 45° MD cr									
															<b>NA5187</b> 30.00x52.00x7.00mm ACM				

# FIAT GROUP

<b>106</b>	<b>78.00</b>	<b>Diesel</b>					
<b>146 B.000</b>	4 Cyl.	20:1	1367cc	<b>52kW (71)PS</b>	<b>Turbo Intercooled</b>	<b>TD947</b>	<b>853</b>
<b>146 B3.000</b>	4 Cyl.	20:1	1367cc	<b>52kW (70)PS</b>	<b>Turbo Intercooled</b>	<b>TD950</b>	<b>853</b>

	<b>.KIT</b>		<b>KIT</b>		
<b>TB515</b>					
<b>165x22</b>					

<b>V91655</b>	<b>7 553 004</b>	<b>MAT.</b>	<b>45°</b>	<b>Ex F x G</b>	
<b>30.00 x 8.00 x 117.00</b>		<b>MD cr</b>			

	<b>DR100</b> ▲	<b>GR100</b> ▲	<b>HBS095</b>		<b>JN459</b>	<b>HR596</b>	<b>NA5187</b>
			<b>M12x1.25x133.00mm (x10)</b>				<b>30.00x52.00x7.00mm ACM</b>

<b>107</b>	<b>78.00</b>	<b>Petrol</b>				
<b>AR 06100</b>	4 Cyl.		1567cc	<b>81kW (110)PS</b>	<b>TD47</b>	<b>854</b>

<b>V90388</b>	<b>605 21 575</b>	<b>MAT.</b>	<b>30°</b>	<b>VAG921688</b>	
<b>37.10 x 8.96 x 106.10</b>		<b>MD</b>		<b>51.00 x 9.00 x 14.05</b>	

<b>BC370</b> Fibre Composite	<b>DC372</b>	<b>GC374</b>		<b>JA840</b>	<b>JP004</b>		
	<b>DC373</b> ▲	<b>GH857</b> ▲ [1]		<b>01/76 → 12/82</b>			
				<b>JC497</b>			
				<b>01/83 → 12/84</b>			
				<b>JA829</b> (x4)			
				<b>JE696</b>			



**BC370**  
 [1] Without crankshaft seal                      [1] sans bague d'étanchéité - vilebrequin                      [1] senza paraolio-albero a gomiti                      [1] sin cigüeñal retén

<b>108</b>	<b>78.00</b>	<b>Petrol</b>	
AR 00526	4 Cyl.	9:1	1570cc
			<b>71-81kW (97-110)PS</b>
			<b>TD22 856</b>

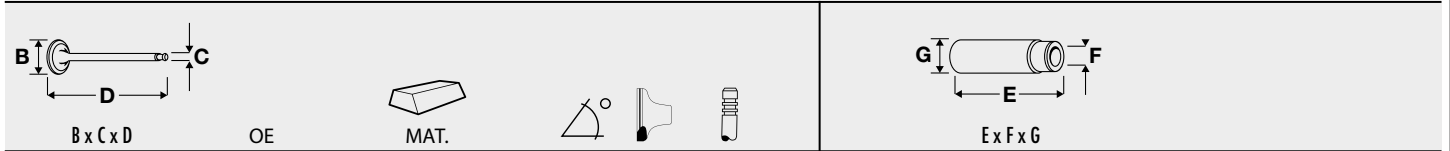

<b>V90388</b>	OE	<b>MAT.</b>		<b>VAG92168B</b>
605 21 575			30°	
37.10 x 8.96 x 106.10		MD		51.00 x 9.00 x 14.05

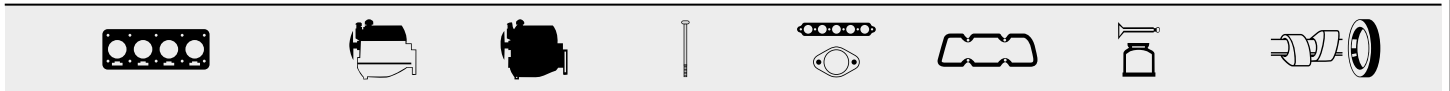

<b>AF370</b> Fibre Composite	<b>CF24N</b> ▲ [1]	<b>HBS186</b> △				
		M14x2.00x137.00mm (x10)				



**AF370**  
 [1] Without crankshaft seal      [1] sans bague d'étanchéité - vilebrequin      [1] senza paraolio-albero a gomiti      [1] sin cigüeñal retén

<b>109</b>	<b>78.00</b>	<b>Petrol</b>	
AR 00536	4 Cyl.	1570cc	<b>80kW (109)PS</b>
			<b>TD24 856</b>

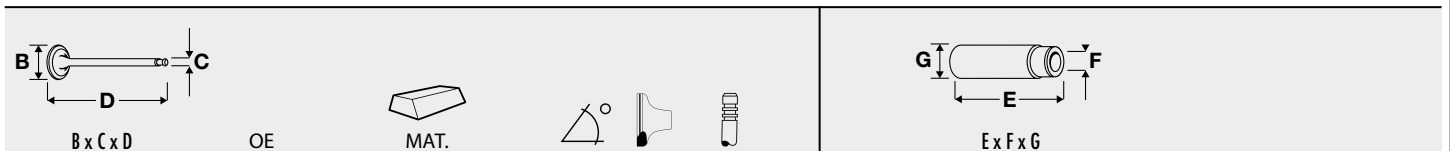

<b>V90388</b>	OE	<b>MAT.</b>		<b>VAG92168B</b>
605 21 575			30°	
37.10 x 8.96 x 106.10		MD		51.00 x 9.00 x 14.05

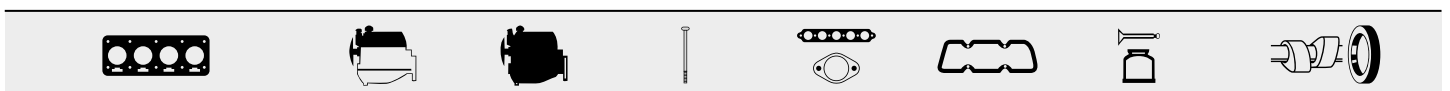

<b>CF24N</b> ▲ [1]	<b>FF24R</b> ▲ [1]				

[1] Without crankshaft seal      [1] sans bague d'étanchéité - vilebrequin      [1] senza paraolio-albero a gomiti      [1] sin cigüeñal retén

<b>110</b>	<b>78.00</b>	<b>Petrol</b>	
AR 01600	4 Cyl.	1570cc	<b>79-80kW (108-109)PS</b>
			<b>TD32 856</b>

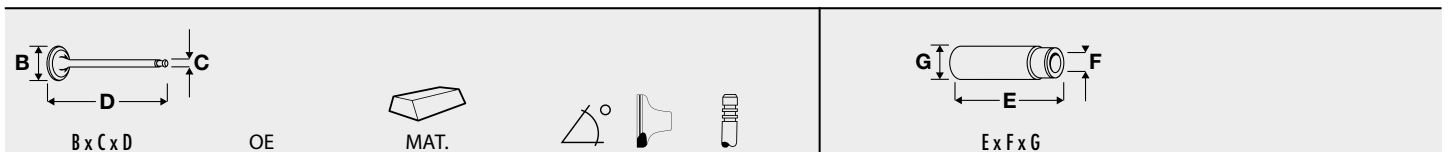

<b>V90388</b>	OE	<b>MAT.</b>		<b>VAG92168B</b>
605 21 575			30°	
37.10 x 8.96 x 106.10		MD		51.00 x 9.00 x 14.05

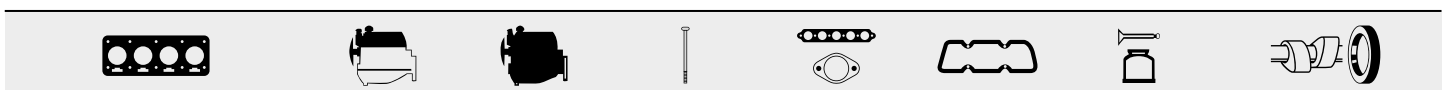

<b>AF370</b> Fibre Composite	<b>DC372</b>	<b>FF24R</b> ▲ [1]	<b>JA840</b>	<b>JA829</b>		



**AF370**  
 [1] Without crankshaft seal      [1] sans bague d'étanchéité - vilebrequin      [1] senza paraolio-albero a gomiti      [1] sin cigüeñal retén

# FIAT GROUP

## 111



78.00

Petrol



M16A Euro4/Euro5

4 Cyl.

10.5:1

1586cc

78-88kW (106-120)PS

TD20932

858

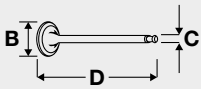

B x C x D

OE



MAT.



45°



H

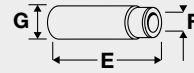

E x F x G

**V95007** ■  
12911-69G00  
30.00 x 6.00 x 100.80  
→12/03

**V95008** ■  
12915-69G50  
25.00 x 6.00 x 99.10  
→12/03

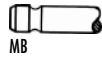

MB

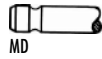

MD

45° ss

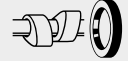
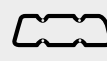

AG8180 MLS

**HBS497** ☉  
M10x1.50x149.00mm (x10)

**JD5965** ■  
MLS

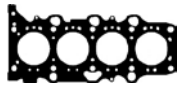

AG8180

## 112



78.10

Petrol



AR 61101

4 Cyl.

1567cc

76-81kW (103-110)PS

TD102

859

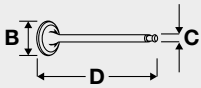

B x C x D

OE



MAT.



30°



MD

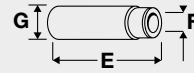

E x F x G

**V90388** ■  
605 21 575  
37.10 x 8.96 x 106.10

**VAG921688** ■  
51.00 x 9.00 x 14.05

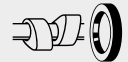
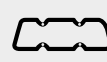

BC370 Fibre Composite

**DC372**  
**DC373** ▲

**GC374**  
**GH857** ▲ [1]

**JA840** ■  
01/76→12/82  
**JC497** ■  
01/83→12/84  
**JA829** ■ (x4)  
☉ **JE696**

**JP004**



BC370

[1] Without crankshaft seal

[1] sans bague d'étanchéité - vilebrequin

[1] senza paraolio-albero a gomiti

[1] sin cigüeñal retén

## 113



78.10

Petrol



AR 01563

4 Cyl.

1570cc







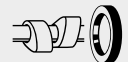
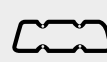

79kW (107)PS





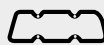

TD29

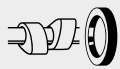

860

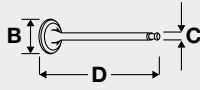
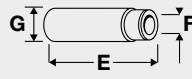











DC372

<b>114</b>	 <b>79.00</b>	<b>Petrol</b>				
192 B3.000	4 Cyl.	10.5:1	1598cc	77kW (105)PS	TD22147	<b>862</b>
       						
						NC006 35.00x48.00x7.00mm MVQ

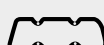
<b>115</b>	 <b>79.38</b>	<b>Diesel</b>				
4.108	4 Cyl.	22:1	1760cc	38kW (52)PS	TD141	<b>863</b>
						
B x C x D	OE	MAT.			E x F x G	
V3251 ■	732 101 M1		45°	H	VAG701 ■	
35.99 x 7.95 x 117.04		MB			54.00 x 8.03 x 12.77	
V3252 ■	0 910 061		45°	H	VAG586 ■	
30.43 x 7.93 x 117.25		MB			62.00 x 8.01 x 12.76	

<b>116</b>	 <b>79.50</b>	<b>Diesel</b>					
198 A2.000	4 Cyl.	16.1:1	1598cc	88kW (120)PS	Turbo Intercooled	TD21042	<b>864</b>
198 A2.000	4 Cyl.	16.1:1	1598cc	88kW (120)PS	Turbo Intercooled	TD21047	<b>864</b>
198 A2.000	4 Cyl.	16.5:1	1598cc	88kW (120)PS	Turbo Intercooled	TD21698	<b>864</b>
198 A3.000	4 Cyl.	16.5:1	1598cc	77kW (105)PS	Turbo Intercooled	TD24568	<b>865</b>
263 A3.000	4 Cyl.	16.5:1	1598cc	74kW (101)PS		TD24768	<b>866</b>
350 A2.000	4 Cyl.	16.5:1	1598cc	85-88kW (116-120)PS	Turbo Intercooled	TD22138	<b>867</b>
940 A3.000	4 Cyl.	16.5:1	1598cc	77kW (105)PS	Turbo Intercooled	TD23923	<b>869</b>
955 A3.000 Euro 5	4 Cyl.	16.5:1	1598cc	88kW (120)PS	Turbo Intercooled	TD23575	<b>864</b>
955 A3.000 Euro 5	4 Cyl.	16.5:1	1598cc	88kW (120)PS	Turbo Intercooled	TD24591	<b>864</b>
955 A4.000	4 Cyl.		1598cc	85kW (115)PS	Turbocharged	TD23451	<b>869</b>

					
					FOL187 (x16)

       						
AH6880 MLS, 0.82mm						
AH6890 MLS, 0.92mm, 1 Hole						
AH6900 MLS, 1.02mm, 2 Holes						
						
AH6880	AH6890	AH6900				

# FIAT GROUP

## 117

 79.50

### Diesel



198 A6.000	4 Cyl.	16.5:1	1598cc	66kW (90)PS	Turbo Intercooled	TD24596	866
199 B5.000 Euro 5	4 Cyl.	17.8:1	1598cc	77kW (105)PS	Turbo Intercooled	TD27727	
263 A4.000	4 Cyl.	16.5:1	1598cc	66kW (90)PS	Turbo Intercooled	TD24769	866
350 A2.000	4 Cyl.	16.5:1	1598cc	85-88kW (116-120)PS	Turbo Intercooled	TD24899	867
350 A3.000	4 Cyl.	16.5:1	1598cc	85kW (116)PS	Turbo Intercooled	TD24973	
350 A3.000	4 Cyl.	16.5:1	1598cc	85kW (116)PS	Turbo Intercooled	TD24974	866
944 A 3.000	4 Cyl.	16.5:1	1598cc	77kW (105)PS	Turbo Intercooled	TD25422	866
955 A4.000	4 Cyl.	16.5:1	1598cc	85kW (116)PS	Turbo Intercooled	TD24651	869
955 A4.000	4 Cyl.		1598cc	85kW (115)PS	Turbocharged	TD25735	869

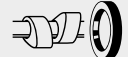
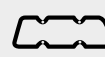

AH6880 MLS, 0.82mm

AH6890 MLS, 0.92mm, 1 Hole

AH6900 MLS, 1.02mm, 2 Holes



AH6880

AH6890

AH6900

## 118

 80.00

### Petrol



128 A.000	4 Cyl.	8.8:1	1116cc	33-48kW (45-65)PS		TD888	871
-----------	--------	-------	--------	-------------------	--	-------	-----



[6] Mechanical

[6] Mécanique

[6] Meccanico

[6] Mecánico

CAM517

FOL104 (x8) [6]

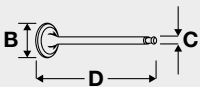

B x C x D

OE



MAT.



45°



H

V34496 ■

4 239 917



MB

36.00 x 8.00 x 108.50

V90071 ■

4 315 062

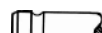

MD cr

30.99 x 8.00 x 109.09

V91713 ■

4 315 062

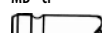

MD cr

31.00 x 8.00 x 109.00

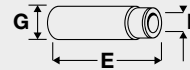

E x F x G

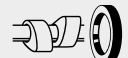
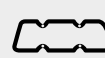

BP070 Fibre Composite

DJ851 ▲  
DP070

 GP070

JD146

 JE390

JM663 ■

JN805 ■











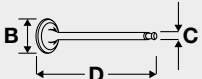
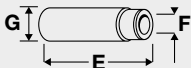

HR596 ■











NA5187

30.00x52.00x7.00mm ACM

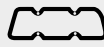

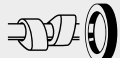





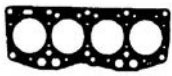



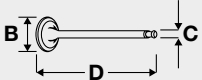
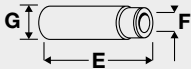

BP070











<b>119</b>		 <b>80.00</b>	<b>Petrol</b>			
<b>128 A.048</b>	4 Cyl.	9.2:1	1116cc	<b>33kW (45)PS</b>	<b>TD5378</b>	<b>871</b>
						
B x C x D	OE	MAT.				E x F x G
<b>V34496</b> 	4 239 917		45°		H	
36.00 x 8.00 x 108.50		MB				
<b>V90071</b> 	4 315 062		45°			
30.99 x 8.00 x 109.09		MD cr				
<b>V91713</b> 	4 315 062		45°			
31.00 x 8.00 x 109.00		MD cr				

							
<b>BP070</b> Fibre Composite	<b>DJ851</b> ▲ DP070	<b>GP070</b>		<b>JD146</b> JE390	<b>JM663</b>  <b>JN805</b> 	<b>HR596</b> 	<b>NA5187</b> 30.00x52.00x7.00mm ACM

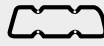

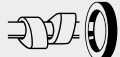
BP070

<b>120</b>		 <b>80.00</b>	<b>Petrol</b>			
<b>128 AC5.000</b>	4 Cyl.	9.2:1	1116cc	<b>48kW (65)PS</b>	<b>TD891</b>	<b>872</b>
						
B x C x D	OE	MAT.				E x F x G
<b>V34496</b> 	4 239 917		45°		H	
36.00 x 8.00 x 108.50		MB				
<b>V90071</b> 	4 315 062		45°			
30.99 x 8.00 x 109.09		MD cr				
<b>V91713</b> 	4 315 062		45°			
31.00 x 8.00 x 109.00		MD cr				

							
	<b>DJ851</b> ▲	<b>GP070</b>			<b>JM663</b>  <b>JN805</b> 	<b>HR569</b> 	

# FIAT GROUP

## 121



80.00

Petrol



138 B.000      4 Cyl.      9.2:1      1116cc      40-44kW (55-60)PS      TD923      871

<b>TB114</b> 116x19 12/83 → 12/88					

 B x C x D	OE	MAT.			 E x F x G
<b>V34496</b>	4 239 917		45°	H	<b>VAG92366</b> 46.50 x 8.00 x 14.10
<b>V90071</b>	4 315 062		45°		
<b>V91713</b>	4 315 062		45°		

<b>BJ850</b> Fibre Composite	<b>DJ852</b>	<b>GJ852</b>	<b>HBS051</b> M10x1.25x98.00mm (x5)	<b>JD146</b>	<b>JP049</b> (Cork) <b>JN805</b>	<b>HR596</b>	<b>NA5187</b> 30.00x52.00x7.00mm ACM



BJ850

## 122



80.00

Petrol



138 B1.000      4 Cyl.      9.6:1      1116cc      40kW (55)PS      TD924      873

<b>TB114</b> 116x19					

 B x C x D	OE	MAT.			 E x F x G
<b>V34496</b>	4 239 917		45°	H	<b>VAG92366</b> 46.50 x 8.00 x 14.10
<b>V90071</b>	4 315 062		45°		
<b>V91713</b>	4 315 062		45°		

<b>BJ850</b> Fibre Composite	<b>DJ852</b>	<b>GJ852</b>	<b>HBS051</b> M10x1.25x98.00mm (x5)	<b>JD146</b>	<b>JP049</b> (Cork) <b>JN805</b>	<b>HR596</b>	<b>NA5187</b> 30.00x52.00x7.00mm ACM



BJ850



## 123

 80.00

Petrol



138 C1.000

4 Cyl.







9.2:1











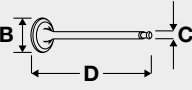

1116cc

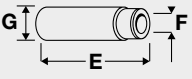









40-42kW (55-57)PS

TD18371

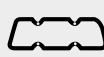
873

					
<b>TB114</b> 116x19					

						
B x C x D	OE	MAT.				E x F x G
<b>V34496</b> 	4 239 917		45°		H	<b>VAG92366</b> 
36.00 x 8.00 x 108.50		MB				46.50 x 8.00 x 14.10
<b>V90071</b> 	4 315 062		45°			
30.99 x 8.00 x 109.09		MD cr				
<b>V91713</b> 	4 315 062		45°			
31.00 x 8.00 x 109.00		MD cr				

							
<b>BJ850</b> Fibre Composite	<b>DJ852</b>		<b>HBS051</b> 	<b>JD146</b>	<b>JP049</b>  (Cork) <b>JN805</b> 	<b>HR596</b> 	<b>NA5187</b> 30.00x52.00x7.00mm ACM



BJ850

**124**

 **80.00**

**Petrol**



146 A4.044

4 Cyl.







9.2:1









1116cc

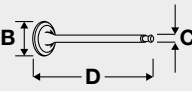

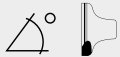

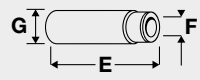



37kW (50)PS

TD9469

**873**



					
<b>TB114</b> 116x19 →12/86	<b>TBK006</b> Eng.→9042883 Component No: TB129; AE1008TP		<b>KIT</b>		
<b>TB129</b> 104x15 Eng.→9042883	<b>TBK314</b> Eng.9042884→				
<b>TB676</b> 125x15 Eng.9042884→	Component No: TB676; AE1008TP				

					
B x C x D	OE	MAT.			E x F x G
<b>V34496</b> ■ 36.00 x 8.00 x 108.50	4 239 917		45°	H	
<b>V90071</b> ■ 30.99 x 8.00 x 109.09	4 315 062		45°		
<b>V91713</b> ■ 31.00 x 8.00 x 109.00	4 315 062		45°		







							
<b>BJ850</b> Fibre Composite	<b>DJ851</b> ▲ <b>DJ852</b>	<b>GJ852</b>	<b>HBS051</b> △ M10x1.25x98.00mm (x5)	<b>JD146</b>	<b>JP049</b> ▣ (Cork) <b>JN805</b> ▣	<b>HR596</b> ▣	<b>NA5187</b> 30.00x52.00x7.00mm ACM











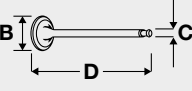



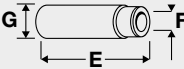









**BJ850**

**125**  **80.00** **Petrol** 

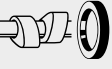

146 A4.048 4 Cyl. 9.2:1 1116cc 43kW (58)PS TD4375 **873**

					
<b>TB114</b> 116x19 <b>TB248</b> 118x15 06/89→					



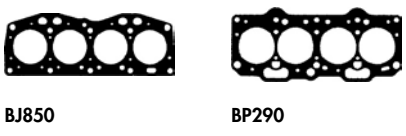



	OE				
<b>V34496</b>  36.00 x 8.00 x 108.50	4 239 917		45°	H	<b>VAG92366</b>  46.50 x 8.00 x 14.10
<b>V90071</b>  30.99 x 8.00 x 109.09	4 315 062		45°		
<b>V91713</b>  31.00 x 8.00 x 109.00	4 315 062		45°		









							
<b>BJ850</b> Fibre Composite <b>BP290</b> Fibre Composite	<b>DJ851</b> ▲ DJ852	<b>GJ852</b>	<b>HBS098</b>  M12x1.25x140.00mm (x5)	<b>JD146</b>	<b>JN283</b> <b>JP049</b>  (Cork) <b>JN805</b> 	<b>HR596</b> 	<b>NA5187</b> 30.00x52.00x7.00mm ACM

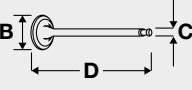



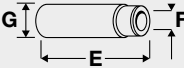







**126**  **80.00** **Petrol** 

146 A6.000 4 Cyl. 9.35:1 1116cc 43kW (58)PS TD9493 **874**

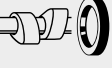
					
<b>TB248</b> 118x15					

	OE				
<b>V90398</b>  36.60 x 7.98 x 110.50	4 412 816		45°	H	
<b>V90399</b>  29.10 x 7.99 x 110.50	4 340 119		45°		

							
<b>BP290</b> Fibre Composite	<b>DP293</b>	<b>GK590</b>	<b>HBS098</b>  M12x1.25x140.00mm (x5)	<b>JD146</b> <b>JD5155</b> (x2)	<b>JN283</b> <b>JP049</b>  (Cork) <b>JN805</b> 	<b>HR596</b> 	<b>NA5187</b> 30.00x52.00x7.00mm ACM

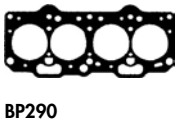

# FIAT GROUP

**127**



**80.00**

**Petrol**



146 A9.000

4 Cyl.

1116cc

40kW (55)PS

TD945

**875**



**TB248**  
118x15

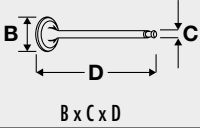

OE



MAT.



45°



H

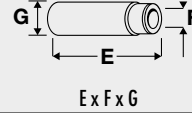

**V90398** ■  
36.60 x 7.98 x 110.50  
**V90399** ■  
29.10 x 7.99 x 110.50

4 412 816



MB

45°



MD

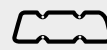

BP290 Fibre Composite

DP293

**GK590**

**HBS098** Ⓢ  
M12x1.25x140.00mm (x5)

**JD146**  
**JD5155** (x2)

**JN283**

**HR596** ■

**NA5187**  
30.00x52.00x7.00mm ACM



BP290

**128**



**80.00**

**Petrol**



146 C3.000

4 Cyl.

9.2:1

1116cc

36kW (49)PS

TD4348

**876**



**TB129**  
104x15  
Eng.→9042883  
**TB676**  
125x15  
Eng.9042884→

**TBK006**  
Eng.→9042883  
Component No: TB129;  
AE1008TP  
**TBK314**  
Eng.9042884→  
Component No: TB676;  
AE1008TP

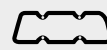

BP280 Fibre Composite, 1.650mm  
BV940 Fibre Composite, 2.000mm

DV675

**GP282**

**HBS052** Ⓢ  
M9x1.25x95.00mm (x10)

**JD148** ■  
**JD5375** ■  
JF145  
MLS

















**JN667**







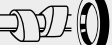





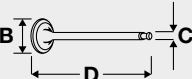



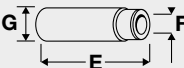

**HR599** ■







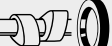



**NA5053**  
30.00x42.00x7.00mm FPM



BP280, BV940

<b>129</b>	 <b>80.00</b>	<b>Petrol</b>	
<b>831 B8.000</b>	4 Cyl.	1116cc	<b>47kW (64)PS</b>
<b>TB114</b>			<b>TD1819 877</b>
116x19	 	 	 
			    
			<b>HBS051</b>  M10x1.25x98.00mm (x5)

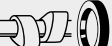
<b>130</b>	 <b>80.00</b>	<b>Petrol</b>	
<b>AR 30102</b>	4 Cyl.	1186cc	<b>46kW (63)PS</b>
<b>AR 30102 S</b>	4 Cyl.	1186cc	<b>44kW (60)PS</b>
<b>AR 30500</b>	4 Cyl.	1186cc	<b>44-50kW (60-68)PS</b>
<b>TD5335 878</b>			<b>TD5336 879</b>
<b>TD87 881</b>			
 $B \times C \times D$	OE	 MAT.	 45°  ss
<b>V90392</b> 	10289.60000.00	 MD cr	 $E \times F \times G$
33.10 x 8.00 x 92.90			
			    
	<b>CN353</b>		<b>JA899</b>  (x4) <b>JN588</b> <b>NA5064</b> 35.00x58.00x10.00mm ACM

<b>131</b>	 <b>80.00</b>	<b>Petrol</b>	
<b>AR 30104</b>	4 Cyl.	9:1 1186cc	<b>50kW (68)PS</b>
<b>AR 30160</b>	4 Cyl.	9:1 1351cc	<b>51kW (69)PS</b>
<b>TD77 880</b>			<b>TD81 878</b>
			    
	<b>CN353</b>		<b>JA899</b>  (x4) <b>JN588</b> (x2) <b>HR602</b> <b>NA5064</b> 35.00x58.00x10.00mm ACM

# FIAT GROUP

## 132



80.00

Petrol



AR 30585      4 Cyl.      1186cc      50kW (68)PS      TD10129      882

<b>TB106</b> 98x17 05/87→					

 B x C x D	OE	 MAT.	 45°	 H	 E x F x G
<b>V91629</b> ■ 39.80 x 8.00 x 92.00	605 40 326	 MB	45°		<b>VAG96261</b> ■ ■ 40.50 x 8.02 x 13.08
<b>V91630</b> ■ 33.10 x 8.00 x 92.10	605 40 325	 MD cr	45°		

<b>AN350</b> Fibre Composite (x2)	<b>CN353</b>			<b>JA899</b> ■ (x4) JE696	<b>JN588</b>		<b>NA5064</b> 35.00x58.00x10.00mm ACM



AN350

## 133



80.00

Petrol



AR 31000      4 Cyl.      9:1      1186cc      44-47kW (60-64)PS      TD99      878

 B x C x D	OE	 MAT.	 45°	 ss	 E x F x G
<b>V90392</b> ■ 33.10 x 8.00 x 92.90	10289.60000.00	 MD cr	45°		

	<b>CN353</b>						<b>NA5064</b> 35.00x58.00x10.00mm ACM

## 134



80.00

Petrol



AR 30180      4 Cyl.      1286cc      48-50kW (65-68)PS      TD84      879

	<b>CN353</b>						

## 135



80.00

Petrol



AR 30100      4 Cyl.      1351cc      58kW (79)PS      TD76      884

							<b>NA5064</b> 35.00x58.00x10.00mm ACM

<b>136</b>	<b>80.00</b>	<b>Petrol</b>				
AR 30164	4 Cyl.	9:1	1351cc	55kW (75)PS	TD82	880
<b>TB106</b> 98x17						
<b>V90392</b> 33.10 x 8.00 x 92.90	10289.60000.00		45°	ss		
	CN353			<b>JA899</b> (x4)	<b>JN588</b> (x2)	<b>HR602</b> <b>NA5064</b> 35.00x58.00x10.00mm ACM

<b>137</b>	<b>80.00</b>	<b>Petrol</b>				
AR 30168	4 Cyl.	9.5:1	1351cc	63-66kW (85-90)PS	TD83	880
<b>TB106</b> 98x17 →02/87						
<b>V91614</b> 38.00 x 8.00 x 97.00	129661		45°	H	<b>VAG96261</b> 40.50 x 8.02 x 13.08	
<b>V91615</b> 33.00 x 7.98 x 97.50	605 04 784		45°			
<b>AN350</b> Fibre Composite	CN353			<b>JA899</b> (x4) 	<b>JN588</b> (x2)	<b>HR602</b> <b>NA5064</b> 35.00x58.00x10.00mm ACM



AN350

# FIAT GROUP

## 138



80.00

Petrol



AR 30502	4 Cyl.	9:1	1351cc	55-58kW (75-79)PS	TD88	880
AR 30586	4 Cyl.		1351cc	55kW (75)PS	TD96	880
AR 30587	4 Cyl.		1351cc	63-66kW (86-90)PS	TD97	878

<b>TB106</b> 98x17					

<b>V90392</b> 33.10 x 8.00 x 92.90	10289.60000.00 	45°	ss	E x F x G

<b>AN350</b> Fibre Composite	<b>CN353</b>	<b>JA899</b> (x4)	<b>JN588</b> (x2)	<b>HR602</b>	<b>NA5064</b> 35.00x58.00x10.00mm ACM



AN350

## 139



80.00

Petrol



AR 30753	4 Cyl.	9.5:1	1351cc	65-66kW (88-90)PS	TD119	885
----------	--------	-------	--------	-------------------	-------	-----

<b>TB338</b> 100x17	<b>TBK287</b> Component No: TB338; AE1006TP;AE1007TP				

<b>V91629</b> 39.80 x 8.00 x 92.00	605 40 326 	45°	H	E x F x G
<b>V91630</b> 33.10 x 8.00 x 92.10	605 40 325 	45°		



<b>140</b>	<b>80.00</b>	<b>Petrol</b>							
AR 30755	4 Cyl.	9.5:1	1351cc	65-66kW (88-90)PS				TD120	<b>885</b>
AR 33501	4 Cyl.		1351cc	66kW (90)PS				TD123	<b>885</b>

<b>TB338</b> 100x17	<b>TBK287</b> Component No: TB338; AE1006TP;AE1007TP		<b>KIT</b>		

B x C x D	E x F x G
<b>V91629</b> 39.80 x 8.00 x 92.00	<b>VAG96261</b> 40.50 x 8.02 x 13.08
OE: 605 40 326	
MAT. MB	
MAT. MD cr	
45°	
H	

AN350 Fibre Composite	CN353	JA899  (x4) JE744	JN588 (x2)	HR363 HR602		NA5064 35.00x58.00x10.00mm ACM



AN350

<b>141</b>	<b>80.00</b>	<b>Petrol</b>							
AR 31010	4 Cyl.	9:1	1351cc	63kW (86)PS				TD100	<b>878</b>

B x C x D	E x F x G
<b>V90392</b> 33.10 x 8.00 x 92.90	
OE: 10289.60000.00	
MAT. MD cr	
45°	
ss	



CN353 DE622	JE744	NA5064 35.00x58.00x10.00mm ACM









<b>142</b>	<b>80.00</b>	<b>Petrol</b>							
AR 01644	4 Cyl.		1357cc	66-70kW (90-95)PS				TD35	<b>886</b>

B x C x D	E x F x G
<b>V90388</b> 37.10 x 8.96 x 106.10	<b>VAG92168B</b> 51.00 x 9.00 x 14.05
OE: 605 21 575	<b>VAG92168</b> 54.00 x 9.01 x 14.05
MAT. MD	
30°	

JA840 JA829	

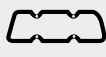

# FIAT GROUP









<b>143</b>	 <b>80.00</b>	<b>Petrol</b>				
124 AC.000	4 Cyl.	8.9:1	1438cc	59-66kW (80-90)PS	TD13413	<b>887</b>



							
AH020 Fibre Composite					JM085	HR569 	

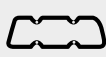









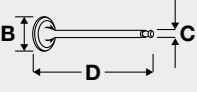



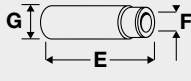

AH020

<b>144</b>	 <b>80.00</b>	<b>Petrol</b>				
124 B2.000	4 Cyl.	9:1	1438cc	51-55kW (70-75)PS	TD13412	<b>888</b>

							
		FG615		JE390		HR569 	

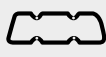

<b>145</b>	 <b>80.00</b>	<b>Petrol</b>				
828 A2.000	4 Cyl.		1438cc	66kW (90)PS	TD1793	<b>889</b>

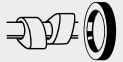







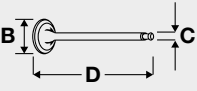

	OE					
<b>V90070</b> 	4 359 309		45°	ss		<b>VAG51023B</b> 
36.10 x 8.00 x 105.79		MD cr				47.00 x 8.04 x 15.04



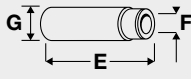



							
AH020 Fibre Composite							







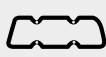



AH020

<b>146</b>	 <b>80.00</b>	<b>Petrol</b>				
132 A.000	4 Cyl.	9:1	1592cc	72kW (98)PS	TD19053	<b>891</b>

	OE					
<b>V90070</b> 	4 359 309		45°	ss		<b>VAG51023B</b> 
36.10 x 8.00 x 105.79		MD cr				47.00 x 8.04 x 15.04
<b>V91714</b> 	4 469 661		45°			
36.50 x 8.00 x 105.79		MD cr				

							
					JM085		

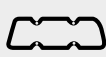
<b>147</b>	 <b>80.00</b>	<b>Petrol</b>				
132 A.9000	4 Cyl.	9:1	1592cc	70kW (95)PS	TD21277	<b>892</b>

							
					JM085		

<b>148</b>	<b>80.00</b>	<b>Petrol</b>			
<b>132 AC.000</b>	4 Cyl.	1592cc	<b>74-81kW (100-110)PS</b>	<b>TD907</b>	<b>895</b>
					<b>FOL104 (x8) [6]</b>

[6] Mechanical      [6] Mécanique      [6] Meccanico      [6] Mecánico

B x C x D	OE
<b>V90070</b>	4 359 309
36.10 x 8.00 x 105.79	
<b>V91714</b>	4 469 661
36.50 x 8.00 x 105.79	MD cr
	45° ss
	45°
	<b>VAG51023B</b>
	47.00 x 8.04 x 15.04

					<b>JM085</b>		

<b>149</b>	<b>80.00</b>	<b>Petrol</b>			
<b>132 BB OA O</b>	4 Cyl.	9:1	1592cc	<b>71-72kW (97-98)PS</b>	<b>TD6825</b> <b>896</b>

					<b>FOL104 (x8) [6]</b>

[6] Mechanical      [6] Mécanique      [6] Meccanico      [6] Mecánico

<b>BK540</b> Fibre Composite				<b>JA777</b>	<b>JM085 (x2)</b>		<b>NA5187</b>
				(Graphite)	<b>JM508</b>		30.00x52.00x7.00mm ACM
				<b>JA757</b>			













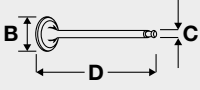



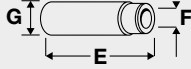









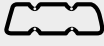

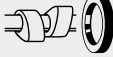





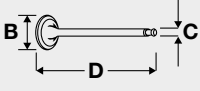



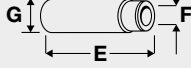





**BK540**



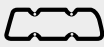

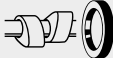





<b>150</b>	<b>80.00</b>	<b>Petrol</b>			
<b>125 A.000</b>	4 Cyl.	8.8:1	1608cc	<b>66kW (90)PS</b>	<b>TD878</b> <b>897</b>



					<b>JM085</b>	<b>HR569</b>	

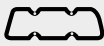

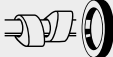





# FIAT GROUP

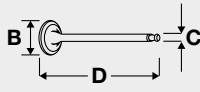



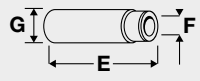

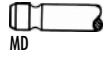

<b>151</b>	 <b>80.00</b>	<b>Petrol</b>					
<b>125 B.000</b>	4 Cyl.	8.8:1	1608cc	<b>74kW (100)PS</b>	<b>TD879</b>	<b>897</b>	
	$B \times C \times D$	OE	 MAT.	 $45^\circ$	 ss		$E \times F \times G$
<b>V90070</b> 	4 359 309	 MD cr	$36.10 \times 8.00 \times 105.79$	<b>VAG51023B</b> 	$47.00 \times 8.04 \times 15.04$		
<b>V91714</b> 	4 469 661	 MD cr	$36.50 \times 8.00 \times 105.79$				
							
					<b>JM085</b>	<b>HR569</b> 	

<b>152</b>	 <b>80.00</b>	<b>Petrol</b>					
<b>AR 00548</b>	4 Cyl.	1779cc	<b>83-97kW (113-132)PS</b>	<b>TD18</b>	<b>898</b>		
	$B \times C \times D$	OE	 MAT.	 $30^\circ$			$E \times F \times G$
<b>V90388</b> 	605 21 575	 MD	$37.10 \times 8.96 \times 106.10$	<b>VAG92168B</b> 	$51.00 \times 9.00 \times 14.05$		
				<b>VAG96216B</b> 	$54.00 \times 9.01 \times 14.05$		
							
	<b>DC373</b> 			<b>JA840</b> 			
				<b>JA829</b> 			

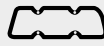

<b>153</b>	 <b>80.00</b>	<b>Petrol</b>					
<b>AR 01354</b>	4 Cyl.	1779cc	<b>110kW (150)PS</b>	<b>Turbocharged</b>	<b>TD5343</b>	<b>899</b>	
							
			<b>HBS186</b> 				
			M14x2.00x137.00mm (x10)				





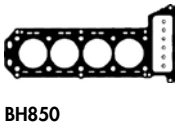



<b>154</b>	 <b>80.00</b>	<b>Petrol</b>			
AR 01608	4 Cyl.	1779cc	87-89kW (118-121)PS	TD5340	<b>898</b>
AR 01678	4 Cyl.	1779cc	88-90kW (120-122)PS	TD38	<b>898</b>

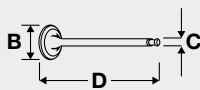



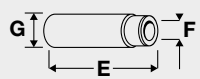

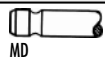

 <p>B x C x D</p>	OE	MAT.	  	 <p>E x F x G</p>
<b>V90388</b>  37.10 x 8.96 x 106.10	605 21 575	 MD	30°	<b>VAG92168B</b>  51.00 x 9.00 x 14.05 <b>VAG96216B</b>  54.00 x 9.01 x 14.05

							
BH850 Fibre Composite	DH854			JA840  JA829 			



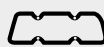





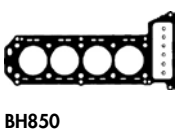



<b>155</b>	 <b>80.00</b>	<b>Petrol</b>			
AR 01608 X	4 Cyl.	1779cc	85kW (115)PS	TD33	<b>898</b>

 <p>B x C x D</p>	OE	MAT.	  	 <p>E x F x G</p>
<b>V90388</b>  37.10 x 8.96 x 106.10	605 21 575	 MD	30°	<b>VAG92168B</b>  51.00 x 9.00 x 14.05 <b>VAG96216B</b>  54.00 x 9.01 x 14.05

							
BH850 Fibre Composite				JA840  JA829 			

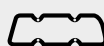

<b>156</b>	 <b>80.00</b>	<b>Petrol</b>				
AR 06134	4 Cyl.	1779cc	110kW (150)PS	Turbocharged	TD50	<b>899</b>
AR 06158	4 Cyl.	1779cc	114kW (155)PS	Turbocharged	TD52	<b>899</b>

							
			HBS186  M14x2.00x137.00mm (x10)		JN806 (MVQ)		

# FIAT GROUP

## 157



80.00

Petrol



AR 06168	4 Cyl.	1779cc	88kW (120)PS	TD54	898
AR 06202	4 Cyl.	1779cc	85-89kW (116-121)PS	TD55	898
AR 61102	4 Cyl.	9:1	1779cc	TD10149	898

<p>B x C x D</p>	<p>OE</p>	<p>MAT.</p>	<p>30°</p>	<p>E x F x G</p>
<p><b>V90388</b> </p> <p>37.10 x 8.96 x 106.10</p>	<p>605 21 575</p>	<p>MD</p>		<p><b>VAG92168B</b> </p> <p>51.00 x 9.00 x 14.05</p> <p><b>VAG96216B</b> </p> <p>54.00 x 9.01 x 14.05</p>

BH850 Fibre Composite	DH854		HBS186 M14x2.00x137.00mm (x10)	JD018 JA829 JE696 (x2)	JN806 (MVQ)		



BH850

## 158



80.00

Petrol











AR 61201	4 Cyl.	1779cc	90kW (122)PS	TD103	900
AR 61202	4 Cyl.	1779cc	87-95kW (118-129)PS	TD5333	899





BH850 Fibre Composite	DH854		HBS186 M14x2.00x137.00mm (x10)	JD018 JA829  (x4) JE696 (x2)	JN806 (MVQ)		





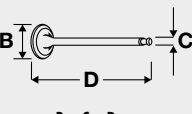



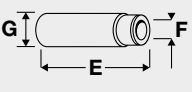

BH850









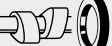

<b>159</b>	 <b>80.00</b>	<b>Petrol</b>					
AR 16202	6 Cyl.	8:1	1996cc	148kW (202)PS	Turbo Intercooled	TD4189	901

					
<b>TB383</b> 134x25.4 →08/02					

	OE					
B x C x D		MAT.				E x F x G

**VAG96263**   
48.50 x 9.00 x 14.05  
**VAG96267**   
42.50 x 9.00 x 14.06

							
---	---	---	---	---	---	---	---

<b>BW290</b> Fibre Composite 	<b>DW282</b> →Eng.7485 <b>DW281</b> Eng.7486→	 <b>GW281</b> →Eng.7485  <b>GW282</b> Eng.7486→		<b>JD222</b>  <b>JD224</b>  (x6)	<b>JM5023</b>  (Steel Elastomer) <b>JN808</b>  →Eng.7485 <b>JM5024</b>  (Steel Elastomer) <b>JN807</b>  →Eng.7485	<b>HR815</b> 	<b>NA5163</b> 32.00x47.00x10.00mm FPM
--	--	--	--	---	--	--	--



BW290

# FIAT GROUP

## 160

80.00

Petrol



AR 34102      6 Cyl.      8:1      1996cc      151kW (205)PS      Turbo Intercooled      TD11600      901

<b>TB703</b> 127x25.4 →10/03					

 B x C x D OE	 E x F x G
 MAT.	 <b>VAG96263</b> 48.50 x 9.00 x 14.05 <b>VAG96267</b> 42.50 x 9.00 x 14.06

<b>AY610</b> Fibre Composite →Eng.004108 <b>CY611</b> Eng.004109→	<b>FY610</b> →Eng.004108 <b>FY611</b> Eng.004109→	<b>JD222</b> (x2) <b>JD224</b> (x6)	<b>JM5023</b> (Steel Elastomer) <b>JN808</b> →Eng.004108 <b>JM5024</b> (Steel Elastomer) <b>JN807</b> →Eng.004108	<b>HR815</b>	<b>NJ951</b> 32.00x50.00x8.00mm FPM	



AY610

## 161

80.00

Petrol



AR 64101      6 Cyl.      8:1      1996cc      150kW (204)PS      Turbocharged      TD5072      902

<b>TB134</b> 134x25.4					

 B x C x D OE	 E x F x G
 MAT.	 <b>VAG96263</b> 48.50 x 9.00 x 14.05

<b>BW290</b> Fibre Composite	<b>DW280</b>	<b>GW280</b>	<b>JD222</b> <b>JD224</b> (x6)	<b>JN808</b> <b>JN807</b>	<b>NA5163</b> 32.00x47.00x10.00mm FPM



BW290



<b>162</b>	<b>80.00</b>	<b>Petrol</b>	
AR 64102	6 Cyl.	1996cc	148-150kW (201-204)PS
			Turbocharged
			TD105 <b>902</b>
<b>TB383</b> 134x25.4 →10/97			

B x C x D	E x F x G
OE	<b>VAG96263</b>
MAT.	48.50 x 9.00 x 14.05

<b>BW290</b> Fibre Composite	<b>DW280</b>	<b>GW280</b>		<b>JD222</b>	<b>JN808</b>			<b>NA5163</b>
				<b>JD224</b> (x6)	<b>JN807</b>			32.00x47.00x10.00mm FPM



BW290

<b>163</b>	<b>80.00</b>	<b>Petrol</b>	
AR 06210	6 Cyl.	1997cc	97kW (132)PS
			TD56 <b>903</b>
<b>TB134</b> 134x25.4			
<b>BW290</b> Fibre Composite	<b>DW280</b>	<b>GW280</b>	<b>JD222</b>
			<b>JD224</b> (x6)
			<b>JN808</b>
			<b>JN807</b>
			<b>NA5163</b>
			32.00x47.00x10.00mm FPM



BW290

# FIAT GROUP

## 164



80.00

Petrol



126 A2.000	2 Cyl.	704cc	19kW (26)PS	TD4342	904
126 A2.048	2 Cyl.	704cc	19kW (26)PS	TD4344	904

B x C x D	OE	E x F x G
<b>V91739</b> ■	4 294 098	 MAT.
32.00 x 8.00 x 115.00		 45°
<b>V91712</b> ■	4 374 855	 MAT.
28.00 x 8.00 x 116.10		 45°

BT860 Fibre Composite	DR480	GR480	JC723 ■ JD198 ■ (x2)	JN666



## 165



80.00

Petrol





















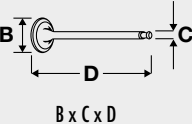
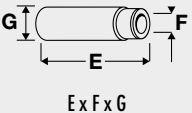











170 A.000	2 Cyl.	704cc	23kW (31)PS	TD1028	905
170 A.046	2 Cyl.	704cc	22kW (30)PS	TD15809	906



















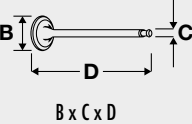
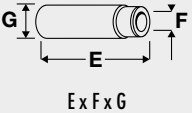











	KIT	FOL171 (x4)

B x C x D	OE	E x F x G
<b>V94793</b> ■	7 683 521	 MAT.
35.30 x 8.00 x 115.80		 45°
<b>V94795</b> ■	7 683 522	 MAT.
27.00 x 8.00 x 116.00		 45°

BT860 Fibre Composite	DT270	GT270	JD067 ■ JD198 ■ (x2)	JN804



<b>166</b>	 <b>80.50</b>	<b>Petrol</b>					
146 A2.000	4 Cyl.	8:1	1301cc	77kW (105)PS	Turbo Intercooled	TD4373	907
 	 						
<b>TB126</b> 118x19							
							
<b>V91307</b> 	7 574 881		45°	ss			
33.00 x 8.00 x 109.00							
							
BP300 Fibre Composite			<b>HBS051</b>  M10x1.25x98.00mm (x5)	<b>LT439</b>    <b>JD021</b> (x2)	<b>JM663</b>   <b>JN805</b> 	<b>HR363</b> 	<b>NA5187</b> 30.00x52.00x7.00mm ACM

<b>167</b>	 <b>80.50</b>	<b>Petrol</b>					
146 A2.146	4 Cyl.		1301cc	73kW (100)PS	Turbocharged	TD938	908
146 A2.246	4 Cyl.		1301cc	74kW (100)PS	Turbocharged	TD932	907
 	 						
<b>TB126</b> 118x19							
							
<b>V91307</b> 	7 574 881		45°	ss			
33.00 x 8.00 x 109.00							
							
BP300 Fibre Composite			<b>HBS051</b>  M10x1.25x98.00mm (x5)	<b>LT439</b>    <b>JD021</b>	<b>JM663</b>   <b>JN805</b> 	<b>HR363</b> 	<b>NA5187</b> 30.00x52.00x7.00mm ACM

# FIAT GROUP

**168**

**80.50**

**Petrol**



146 A8.000

4 Cyl.

7.8:1

1372cc

74-87kW (101-118)PS

Turbocharged

TD18372

909



**TB305**  
138x15  
→12/94

**TBK027**  
→12/94  
Component No: TB305;  
AE1008TP

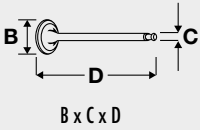

OE



MAT.



45°

ss

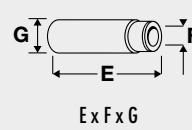

**V91307**   
33.00 x 8.00 x 109.00

7 574 881

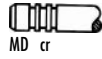

MD cr

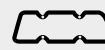

**BT401** Fibre Composite

**DT400**

**GT400**

**HBS051**   
M10x1.25x98.00mm (x5)

**LT439**   
**JD022**

**JP049**   
(Cork)  
**JN805**

**HR363**

**NA5187**  
30.00x52.00x7.00mm ACM



BT401

**169**

**80.50**

**Petrol**



146 A8.046

4 Cyl.

7.8:1

1372cc

82kW (112)PS

Turbocharged

TD944

909



**TB305**  
138x15

**TBK027**  
Component No: TB305;  
AE1008TP

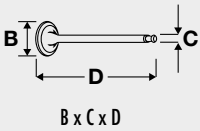

OE



MAT.



45°

ss

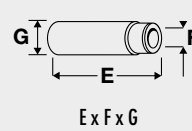

**V91307**   
33.00 x 8.00 x 109.00

7 574 881

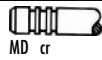

MD cr

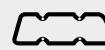

**BT401** Fibre Composite

**DT400**

**GT400**

**HBS051**   
M10x1.25x98.00mm (x5)

**LT439**   
**JD022**



















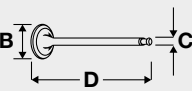



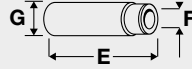







**JP049**   
(Cork)  
**JN805**



**HR363**

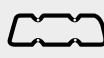















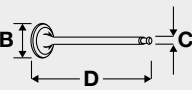



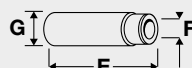









**NA5187**  
30.00x52.00x7.00mm ACM

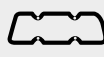

BT401

<b>170</b>	 <b>80.50</b>	<b>Petrol</b>				
<b>146 C1.000</b>	4 Cyl.	9.2:1	1372cc	<b>51-53kW (69-72)PS</b>	<b>TD18821</b>	<b>910</b>
						
<b>TB305</b> 138x15	<b>TBK027</b> Component No: TB305; AE1008TP					
						
B x C x D	OE	MAT.			Ex F x G	
<b>V91300</b>  37.50 x 8.00 x 108.50	7 609 772	 MB	45°	H	<b>VAG92366</b>  46.50 x 8.00 x 14.10	
<b>V90071</b>  30.99 x 8.00 x 109.09	4 315 062	 MD cr	45°			
<b>V91713</b>  31.00 x 8.00 x 109.00	4 315 062	 MD cr	45°			
						
					<b>JP049</b>  (Cork) <b>JN805</b> 	<b>HR569</b> 

<b>171</b>	 <b>80.50</b>	<b>Petrol</b>				
<b>146 C5.000</b>	4 Cyl.	9.2:1	1372cc	<b>49-52kW (67-71)PS</b>	<b>TD6816</b>	<b>910</b>
<b>146 D5.000</b>	4 Cyl.	9.2:1	1372cc	<b>49kW (67)PS</b>	<b>TD6817</b>	<b>910</b>

							
<b>TB305</b> 138x15	<b>TBK027</b> Component No: TB305; AE1008TP						
							
B x C x D	OE	MAT.			Ex F x G		
<b>V91300</b>  37.50 x 8.00 x 108.50	7 609 772	 MB	45°	H	<b>VAG92366</b>  46.50 x 8.00 x 14.10		
<b>V90071</b>  30.99 x 8.00 x 109.09	4 315 062	 MD cr	45°				
<b>V91713</b>  31.00 x 8.00 x 109.00	4 315 062	 MD cr	45°				
							
<b>BT401</b> Fibre Composite	<b>DR620</b>	 <b>GR620</b>	<b>HBS051</b>  M10x1.25x98.00mm (x5)	<b>JD146</b>	<b>JP049</b>  (Cork) <b>JN805</b> 	<b>HR596</b> 	<b>NA5187</b> 30.00x52.00x7.00mm ACM



BT401







## 172

 80.50







Petrol



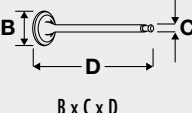
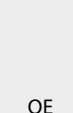
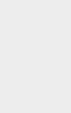
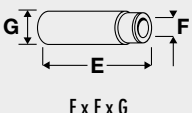

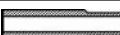









159 A2.000	4 Cyl.	9.2:1	1372cc	57kW (78)PS	TD9728	911
160 A1.000	4 Cyl.	9.2:1	1372cc	52-56kW (71-76)PS	TD1015	911
836 A4.000	4 Cyl.	9.2:1	1372cc	51kW (69)PS	TD893	912

					
<b>TB305</b> 138x15	<b>TBK027</b> Component No: TB305; AE1008TP	<b>CAM719</b>	<b>KIT</b>		<b>FOL104</b> (x8) [6]

[6] Mechanical      [6] Mécanique      [6] Meccanico      [6] Mecánico

			
B x C x D	OE	MAT.	E x F x G
<b>V91300</b> 	7 609 772		<b>VAG92366</b> 
37.50 x 8.00 x 108.50		45°	46.50 x 8.00 x 14.10
<b>V90071</b> 	4 315 062		
30.99 x 8.00 x 109.09		45°	
<b>V91713</b> 	4 315 062		
31.00 x 8.00 x 109.00		45°	

							
<b>BR620</b> Fibre Composite	<b>DR620</b>	<b>GR620</b>	<b>HBS051</b>  M10x1.25x98.00mm (x5)	<b>JD146</b>  <b>JF150</b>	<b>JP049</b>  (Cork) <b>JN805</b> 	<b>HR363</b> 	<b>NA5187</b> 30.00x52.00x7.00mm ACM



BR620

<b>173</b>	<b>80.50</b>	<b>Petrol</b>				
<b>160 A1.046</b>	4 Cyl.	9.2:1	1372cc	<b>49-51kW (67-69)PS</b>	<b>TD1016</b>	<b>912</b>
<b>160 A1.046</b>	4 Cyl.	9.2:1	1372cc	<b>51kW (69)PS</b>	<b>TD4599</b>	<b>913</b>

<b>TB305</b> 138x15	<b>TBK027</b> Component No: TB305; AE1008TP				

B x C x D	OE	MAT.	45°	H	E x F x G
<b>V91300</b>	7 609 772		45°	H	<b>VAG92366</b>
37.50 x 8.00 x 108.50		MB			46.50 x 8.00 x 14.10
<b>V90071</b>	4 315 062		45°		
30.99 x 8.00 x 109.09		MD cr			
<b>V91713</b>	4 315 062		45°		
31.00 x 8.00 x 109.00		MD cr			

<b>BR620</b> Fibre Composite	<b>DR620</b>	<b>GR620</b>	<b>HBS051</b>	<b>JD146</b> <b>JF150</b>	<b>JP049</b> (Cork) <b>JN805</b>	<b>HR363</b>	<b>NA5187</b> 30.00x52.00x7.00mm ACM



BR620

<b>174</b>	<b>80.50</b>	<b>Petrol</b>				
<b>160 A1.048</b>	4 Cyl.	9.2:1	1372cc	<b>50-52kW (69-71)PS</b>	<b>TD4393</b>	<b>912</b>

<b>TB305</b> 138x15	<b>TBK027</b> Component No: TB305; AE1008TP				

B x C x D	OE	MAT.	45°	H	E x F x G
<b>V91300</b>	7 609 772		45°	H	<b>VAG92366</b>
37.50 x 8.00 x 108.50		MB			46.50 x 8.00 x 14.10
<b>V90071</b>	4 315 062		45°		
30.99 x 8.00 x 109.09		MD cr			
<b>V91713</b>	4 315 062		45°		
31.00 x 8.00 x 109.00		MD cr			

<b>BR620</b> Fibre Composite	<b>DR620</b>	<b>GR620</b>	<b>HBS051</b>	<b>JD146</b> <b>JF150</b>	<b>JP049</b> (Cork) <b>JN805</b>	<b>HR363</b> <b>HR569</b>	<b>NA5187</b> 30.00x52.00x7.00mm ACM



BR620

# FIAT GROUP

## 175



80.50

Petrol



176 A4.000	4 Cyl.	7.8:1	1372cc	96-98kW (131-136)PS	Turbo Intercooled	TD1034	914
176 B6.000	4 Cyl.	7.8:1	1372cc	96kW (131)PS	Turbo Intercooled	TD5492	914

<b>TB305</b> 138x15	<b>TBK027</b> Component No: TB305; AE1008TP				<b>FOL104</b> (x8) [6]

[6] Mechanical [6] Mécanique [6] Meccanico [6] Mecánico

<b>V91307</b>	7 574 881		45°	ss	
33.00 x 8.00 x 109.00					

<b>BT401</b> Fibre Composite	<b>DT401</b>	<b>GT401</b>	<b>HBS051</b> M10x1.25x98.00mm (x5)	<b>JD022</b>	<b>JP049</b> (Cork) <b>JN805</b>	<b>HR363</b>	<b>NA5187</b> 30.00x52.00x7.00mm ACM



BT401

## 176



80.50

Petrol



178 B2.000	4 Cyl.	9.2:1	1372cc	51kW (69)PS		TD16173	910
------------	--------	-------	--------	-------------	--	---------	-----

<b>TB305</b> 138x15 07/97→10/03					<b>FOL104</b> (x8) [6]









[6] Mechanical [6] Mécanique [6] Meccanico [6] Mecánico













<b>BR620</b> Fibre Composite	<b>DR620</b>	<b>GR620</b>	<b>HBS051</b> M10x1.25x98.00mm (x5)	<b>JD146</b> <b>JF150</b>	<b>JP049</b> (Cork) <b>JN805</b>	<b>HR363</b>	<b>NA5187</b> 30.00x52.00x7.00mm ACM

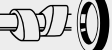

BR620



















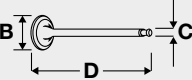
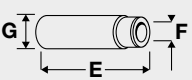

<b>177</b>	 <b>80.50</b>	<b>Petrol</b>				
<b>178 B2.016</b>	4 Cyl.	9.2:1	1372cc	<b>51kW (69)PS</b>	<b>TD16174</b>	<b>910</b>
						
<b>TB305</b> 138x15 07/97→10/03						











							
<b>BR620</b> Fibre Composite	<b>DR620</b>	<b>GR620</b>	<b>HBS051</b>  M10x1.25x98.00mm (x5)	<b>JD146</b>  <b>JF150</b>	<b>JP049</b>  (Cork) <b>JN805</b> 	<b>HR363</b> 	<b>NA5187</b> 30.00x52.00x7.00mm ACM

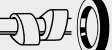

BR620

<b>178</b>	 <b>80.50</b>	<b>Petrol</b>				
<b>836 A4.000</b>	4 Cyl.	9.2:1	1372cc	<b>51kW (69)PS</b>	<b>TD14568</b>	<b>915</b>
						
<b>TB305</b> 138x15	<b>TBK027</b> Component No: TB305; AE1008TP					

					
B x C x D	OE	MAT.			E x F x G
<b>V91300</b> 	7 609 772		45°	H	<b>VAG92366</b>  
37.50 x 8.00 x 108.50		MB			46.50 x 8.00 x 14.10
<b>V90071</b> 	4 315 062		45°		
30.99 x 8.00 x 109.09		MD cr			
<b>V91713</b> 	4 315 062		45°		
31.00 x 8.00 x 109.00		MD cr			

							
<b>BR620</b> Fibre Composite			<b>HBS051</b>  M10x1.25x98.00mm (x5)		<b>JP049</b>  (Cork) <b>JN805</b> 		



BR620

# FIAT GROUP

<b>179</b>	<b>80.50</b>	<b>Petrol</b>			
<b>178 E7.000</b>	4 Cyl.	10.5:1	1596cc	<b>74kW (101)PS</b>	<b>TD25965</b>
					<b>FOL106</b> (x16) Height: 24mm <b>FOL145</b> (x16) Height: 26mm

<b>180</b>	<b>80.50</b>	<b>Petrol</b>				
<b>182 B6.000</b>	4 Cyl.	10.1:1	1596cc	<b>76kW (103)PS</b>	<b>TD15632</b>	<b>916</b>
<b>TB471</b> 158x25.4	<b>TBK089</b> Component No: TB471; AE1086TP;AE1085GP					<b>FOL106</b> (x16) Height: 24mm

B x C x D	E x F x G
OE	
MAT.	
<b>V91949</b> ■ 30.40 x 7.00 x 102.00	<b>VAG50895</b> ■ 46.00 x 7.04 x 13.03
<b>V91950</b> ■ 29.80 x 7.00 x 102.60	<b>VAG92364</b> ■ 42.50 x 7.00 x 13.07
<b>V94468</b> ■ 30.00 x 7.00 x 102.40	
46 517 325	
46 462 159	
46 461 209	
MB cr	
MD cr	
MG cr	
45°	
45°	
45° ss	
H	
H	

<b>AB5150</b> Fibre Composite →Eng.505168 <b>AD5970</b> MLS Eng.505169→	<b>CB5150</b> →Eng.505168 <b>CD5970</b> MLS Eng.505169→	<b>FD5970</b>	<b>HBS131</b> ☒ M10x1.25x100.00mm (x10)	<b>HA5005</b> ■ ■ <b>JD5143</b> ■	<b>JN973</b>	<b>HR800</b> ■	<b>NA5187</b> 30.00x52.00x7.00mm ACM



**AB5150**                      **AD5970**

<b>181</b>	<b>80.50</b>	<b>Petrol</b>				
<b>182 B6.000</b>	4 Cyl.	10.5:1	1596cc	<b>68-100kW (92-136)PS</b>	<b>TD16166</b>	<b>916</b>

<b>TB471</b> 158x25.4	<b>TBK089</b> Component No: TB471; AE1086TP;AE1085GP	<b>CAM716</b> ■ <b>CAM717</b> ■			<b>FOL106</b> (x16) Height: 24mm <b>FOL145</b> (x16) Height: 26mm

<b>B x C x D</b>	<b>E x F x G</b>
<b>OE</b>	<b>MAT.</b>
<b>V91949</b> ■ 30.40 x 7.00 x 102.00	46 517 325 MB cr 45°
<b>V91950</b> ■ 29.80 x 7.00 x 102.60	46 462 159 MD cr 45°
<b>V94468</b> ■ 30.00 x 7.00 x 102.40	46 461 209 MG cr 45° ss H
	<b>VAG50895</b> ■ ■ 46.00 x 7.04 x 13.03
	<b>VAG92364</b> ■ ■ 42.50 x 7.00 x 13.07

<b>AB5150</b> Fibre Composite →Eng.505170 <b>AD5970</b> MLS Eng.505169→	<b>CB5150</b> →Eng.505169 <b>CD5970</b> MLS Eng.505169→	<b>FD5970</b>	<b>HBS131</b> ⊗ M10x1.25x100.00mm (x10)	<b>HA5005</b> ■ ■ <b>JD5143</b> ■	<b>JN973</b>	<b>HR800</b> ■	<b>NA5187</b> 30.00x52.00x7.00mm ACM

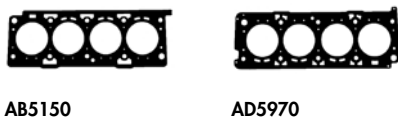

<b>182</b>	<b>80.50</b>	<b>Petrol</b>			
<b>939 A4.000</b>	4 Cyl.	1796cc	<b>96-103kW (131-140)PS</b>	<b>TD20262</b>	<b>917</b>
<b>939 A4.000</b>	4 Cyl.	1796cc	<b>96-103kW (131-140)PS</b>	<b>TD20270</b>	<b>918</b>



<b>TB741</b> 146x24					



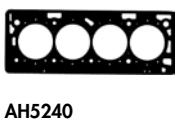





<b>B x C x D</b>	<b>E x F x G</b>
<b>OE</b>	<b>MAT.</b>
<b>V98024</b> ■ 31.00 x 5.00 x 114.00	55557741 MB cr 45°
<b>V98025</b> ■ 27.50 x 5.00 x 113.20	71744388 MG cr 45°



<b>AH5240</b> MLS	<b>CH5240</b>	<b>HBS055</b> ⊗ M10x1.25x153.00mm (x10)	<b>JD5982</b> ■	<b>JM7103</b> (Elastomer)	<b>NC006</b> 35.00x48.00x7.00mm MVQ	











# FIAT GROUP







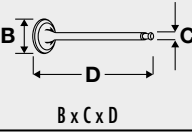
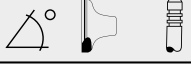
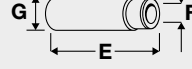

<b>183</b>	 <b>80.50</b>	<b>Petrol</b>			
93313090-7U	4 Cyl.	10.5:1	1796cc	<b>78-84kW</b> (106-114)PS	<b>TD24992 919</b>
93313090-H2	4 Cyl.	10.5:1	1796cc	<b>83-85kW</b> (113-116)PS	<b>TD25004 919</b>
93337154-J1	4 Cyl.	10.5:1	1796cc	<b>82-84kW</b> (112-112)PS	<b>TD25021 919</b>
J2	4 Cyl.	10.5:1	1796cc	<b>83-85kW</b> (113-115)PS	<b>TD25017 919</b>
PN93327668	4 Cyl.	9.4:1	1796cc	<b>76-77kW</b> (103-105)PS	<b>TD24998 919</b>
PN93327669	4 Cyl.	9.8:1	1796cc	<b>90kW</b> (122)PS	<b>TD25025 919</b>
Y2	4 Cyl.	10.5:1	1796cc	<b>83-85kW</b> (113-115)PS	<b>TD25019 919</b>

							
							<b>NC006</b> 35.00x48.00x7.00mm MVQ

<b>184</b>	 <b>82.00</b>	<b>Petrol</b>			
<b>182 A3.000</b>	4 Cyl.	9.8:1	1370cc	<b>59kW</b> (80)PS	<b>TD4399 923</b>

					
<b>TB470</b> 134x18	<b>TBK300</b> Component No: TB470; AE1047TP	<b>CAM648</b>	<b>CKS2648</b> <b>CKS3648</b>	<b>FOL101</b> (x12)	<b>FOL100</b> (x12)

					
B x C x D	OE	MAT.	45°	H	E x F x G
<b>V91927</b> ■ 30.30 x 7.00 x 110.40	7 712 114		45°		<b>VAG96123</b> ■ ■ ■ 42.25 x 7.02 x 13.05
<b>V91928</b> ■ 35.50 x 7.00 x 110.40	46 423 334		45°		<b>VAG96146</b> ■ ■ ■ 42.50 x 7.04 x 13.05







							
<b>AY480</b> Fibre Composite <b>BX040</b> Fibre Composite, 1.200mm	<b>DX040</b>	 <b>GX041</b>	<b>HBS130</b> ☉ M10x1.25x163.00mm (x10)	<b>JD342</b> ■ <b>JD343</b> ■	<b>JN972</b>	<b>HR662</b> ■	<b>NA5053</b> 30.00x42.00x7.00mm FPM











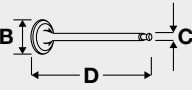
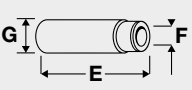









AY480, BX040

## 185 82.00 Petrol

182 A5.000      4 Cyl.      9.8:1      1370cc      55kW (75)PS      TD4401      923

					
<b>TB470</b> 134x18 →02/97	<b>TBK300</b> →02/97 Component No: TB470; AE1047TP	<b>CAM648</b>	<b>CKS2648</b> <b>CKS3648</b>	<b>FOL101</b> (x12)	<b>FOL100</b> (x12)

	
B x C x D	E x F x G
OE	
MAT.	
	
<b>V91927</b> 	<b>VAG96123</b> 
30.30 x 7.00 x 110.40	42.25 x 7.02 x 13.05
<b>V91928</b> 	<b>VAG96146</b> 
35.50 x 7.00 x 110.40	42.50 x 7.04 x 13.05







							
<b>AY480</b> Fibre Composite <b>BX040</b> Fibre Composite, 1.200mm	<b>DX040</b>	<b>GX041</b>	<b>HBS130</b>  M10x1.25x163.00mm (x10)	<b>JD342</b>  <b>JD343</b> 	<b>JN972</b>	<b>HR662</b> 	<b>NA5053</b> 30.00x42.00x7.00mm FPM











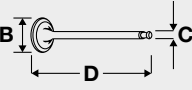











AY480, BX040

## 186 82.00 Petrol

840 A2.000      4 Cyl.      9.85:1      1370cc      55-59kW (75-80)PS      TD1858      923  
840 A4.000      4 Cyl.      9.85:1      1370cc      55kW (75)PS      TD4596      923

					
<b>TB470</b> 134x18 →02/98	<b>TBK300</b> →02/98 Component No: TB470; AE1047TP	<b>CAM648</b>	<b>CKS2648</b> <b>CKS3648</b>	<b>FOL101</b> (x12)	<b>FOL100</b> (x12)

	
B x C x D	E x F x G
OE	
MAT.	
	
<b>V91927</b> 	<b>VAG96146</b> 
30.30 x 7.00 x 110.40	42.50 x 7.04 x 13.05
<b>V91928</b> 	<b>VAG96229</b> 
35.50 x 7.00 x 110.40	42.50 x 7.04 x 13.08

							
<b>AY480</b> Fibre Composite <b>BX040</b> Fibre Composite, 1.200mm	<b>DX040</b>	<b>GX041</b>	<b>HBS130</b>  M10x1.25x163.00mm (x10)	<b>JD342</b>  <b>JD343</b> 	<b>JN972</b>	<b>HR662</b> 	<b>NA5053</b> 30.00x42.00x7.00mm FPM



AY480, BX040

# FIAT GROUP

## 187



82.00

Petrol



AR 33503	4 Cyl.	10.5:1	1370cc	76kW (103)PS	TD9752	924
AR 38501	4 Cyl.		1370cc	76kW (103)PS	TD9753	924

<b>TB528</b> 163x24					<b>FOL106</b> (x16) Height: 24mm <b>FOL145</b> (x16) Height: 26mm

B x C x D	OE	MAT.	45°	H	E x F x G
<b>V91931</b> ■ 30.00 x 7.00 x 113.00	608 12 982	 MB cr	45°	H	<b>VAG96229</b> ■ 42.50 x 7.04 x 13.08
<b>V91932</b> ■ 26.00 x 7.00 x 108.50	608 12 981	 MG cr	45°	H	<b>VAG96230</b> ■ 46.00 x 7.02 x 13.06

<b>BY390</b> Fibre Composite, 1.200mm <b>AY510</b> Fibre Composite, 1.400mm	<b>DY390</b> →05/98 <b>DY391</b> 06/98→	 <b>GY390</b> →05/98  <b>GY391</b> 06/98→	<b>HBS262</b> ☼ M10x1.25x220.00mm (x10)	<b>JD466</b> ■ <b>JD273</b> ■ MLS	<b>HL700</b> ■	<b>HR599</b> ■	<b>NA5053</b> 30.00x42.00x7.00mm FPM
 <b>AY510</b>	 <b>BY390</b>						

## 188



82.00

Petrol



AR 32101	4 Cyl.	10.5:1	1598cc	88kW (120)PS	TD9461	925
----------	--------	--------	--------	--------------	--------	-----

					<b>FOL106</b> (x16) Height: 24mm <b>FOL145</b> (x16) Height: 26mm

## 189



82.00

Petrol



AR 32102

4 Cyl.

1598cc

82-88kW (112-120)PS

TD14369

926

<b>TB528</b> 163x24 05/00→	<b>TBK345</b> →04/00 Component No: TB559; AE1147TP;AE1100TP <b>TBK207</b> 05/00→ Component No: TB528; AE1147TP;AE1100TP				<b>FOL106</b> (x16) Height: 24mm <b>FOL145</b> (x16) Height: 26mm

<b>V91933</b> ■ 33.40 x 7.00 x 113.10	<b>V91934</b> ■ 28.00 x 7.00 x 108.60	<b>V94591</b> ■ 28.00 x 7.00 x 108.80	<b>VAG96146</b> ■ 42.50 x 7.04 x 13.05	<b>VAG96230</b> ■ 46.00 x 7.02 x 13.06

<b>BW720</b> Fibre Composite, 1.650mm <b>AY500</b> Fibre Composite, 1.85mm	<b>DW721</b> →05/98 <b>DW722</b> 06/98→	<b>GW722</b> 05/98→06/00	<b>HBS132</b> ⊗ M10x1.25x254.00mm (x10)	<b>JD271</b> ■ (Metal) <b>JD273</b> ■ MLS	<b>JM5002</b> (Elastomer)	<b>HR599</b> ■	<b>NA5053</b> 30.00x42.00x7.00mm FPM <b>NA5069</b> 55.00x68.00x8.00mm FPM



AY500



BW720

## 190



82.00

Petrol



AR 32103 D4	4 Cyl.	1598cc	88kW (120)PS	TD15389	927
AR 32104	4 Cyl.	1598cc	88kW (120)PS	TD15388	927

<b>TB528</b> 163x24 05/00→	<b>TBK345</b> →04/00 Component No: TB559; AE1147TP;AE1100TP <b>TBK207</b> 05/00→ Component No: TB528; AE1147TP;AE1100TP		<b>KIT</b>		<b>FOL106</b> (x16) Height: 24mm <b>FOL145</b> (x16) Height: 26mm

<b>V91933</b> ■ 33.40 x 7.00 x 113.10	<b>V91934</b> ■ 28.00 x 7.00 x 108.60	<b>V94591</b> ■ 28.00 x 7.00 x 108.80	<b>VAG96146</b> ■ 42.50 x 7.04 x 13.05	<b>VAG96230</b> ■ 46.00 x 7.02 x 13.06
608 11 153	608 11 154	606 74 496		
MB cr	MD cr	MG cr		
45°	45° ss	45° ss		
H		H		

<b>AA5420</b> MLS, 0.380mm <b>BW720</b> Fibre Composite, 1.650mm	<b>CA5420</b>	<b>HBS262</b> ☼ M10x1.25x220.00mm (x10)	<b>JD271</b> ■ (Metal) <b>JD273</b> ■ MLS	<b>JM5002</b> (Elastomer) <b>HL700</b> ■	<b>HR599</b> ■	<b>NA5053</b> 30.00x42.00x7.00mm FPM <b>NA5069</b> 55.00x68.00x8.00mm FPM















AA5420, BW720



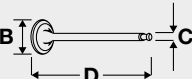
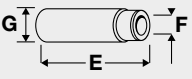











## 191 82.00 Petrol

AR 37203 4 Cyl. 1598cc 76kW (103)PS TD15508 928

					
<b>TB528</b> 163x24	<b>TBK207</b> Component No: TB528; AE1147TP;AE1100TP				<b>FOL106</b> (x16) Height: 24mm <b>FOL145</b> (x16) Height: 26mm

	
B x C x D	E x F x G
OE	
MAT.	
	
45°	H
<b>V91931</b> 	<b>VAG96146</b> 
30.00 x 7.00 x 113.00	42.50 x 7.04 x 13.05
<b>V91932</b> 	<b>VAG96230</b> 
26.00 x 7.00 x 108.50	46.00 x 7.02 x 13.06







							
<b>AA5420</b> MLS, 0.380mm	<b>CA5420</b>		<b>HBS262</b>  M10x1.25x220.00mm (x10)	<b>JD271</b>  (Metal) <b>JD273</b>  MLS	<b>JM5002</b> (Elastomer)	<b>HR599</b> 	<b>NA5053</b> 30.00x42.00x7.00mm FPM <b>NA5069</b> 55.00x68.00x8.00mm FPM











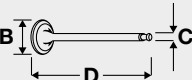
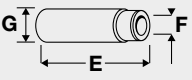











AA5420

## 192 82.00 Petrol

AR 38201 4 Cyl. 1598cc 88kW (120)PS TD9754 926

					
	<b>TBK345</b> Component No: TB559; AE1147TP;AE1100TP				<b>FOL106</b> (x16) Height: 24mm <b>FOL145</b> (x16) Height: 26mm

	
B x C x D	E x F x G
OE	
MAT.	
	
45°	H
<b>V91933</b> 	<b>VAG96146</b> 
33.40 x 7.00 x 113.10	42.50 x 7.04 x 13.05
<b>V91934</b> 	<b>VAG96230</b> 
28.00 x 7.00 x 108.60	46.00 x 7.02 x 13.06
<b>V94591</b> 	
28.00 x 7.00 x 108.80	

							
<b>BW720</b> Fibre Composite, 1.650mm <b>AY500</b> Fibre Composite, 1.85mm	<b>DW721</b> →05/98 <b>DW722</b> 06/98→06/00	<b>GW721</b> →05/98 <b>GW722</b> 06/98→06/00	<b>HBS132</b>  M10x1.25x254.00mm (x10)	<b>JD271</b>  (Metal) <b>JD273</b>  MLS	<b>HL700</b> 	<b>HR599</b> 	<b>NA5053</b> 30.00x42.00x7.00mm FPM <b>NA5069</b> 55.00x68.00x8.00mm FPM



AY500



BW720



AR 67601      4 Cyl.      10.3:1      1598cc      88kW (120)PS      TD19      926

<b>TB528</b> 163x24 05/00→	<b>TBK345</b> →04/00 Component No: TB559; AE1147TP;AE1100TP <b>TBK207</b> 05/00→ Component No: TB528; AE1147TP;AE1100TP				<b>FOL106</b> (x16) Height: 24mm <b>FOL145</b> (x16) Height: 26mm

	OE	MAT.				
<b>V91933</b> ■ 33.40 x 7.00 x 113.10	608 11 153		45°	H		<b>VAG96146</b> ■ 42.50 x 7.04 x 13.05
<b>V91934</b> ■ 28.00 x 7.00 x 108.60	608 11 154		45°	ss		<b>VAG96230</b> ■ 46.00 x 7.02 x 13.06
<b>V94591</b> ■ 28.00 x 7.00 x 108.80	606 74 496		45°	ss	H	

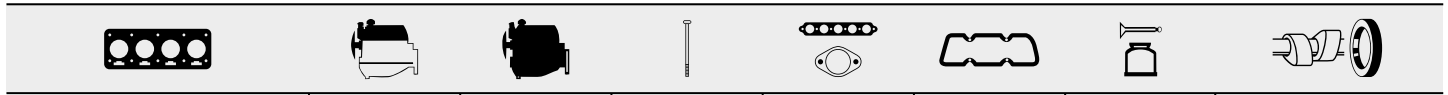

<b>BW720</b> Fibre Composite, 1.650mm <b>AY500</b> Fibre Composite, 1.85mm	<b>DW721</b> →05/98 <b>DW722</b> 06/98→06/00	<b>GW721</b> →05/98 <b>GW722</b> 06/98→06/00	<b>HBS132</b> ☒ M10x1.25x254.00mm (x10)	<b>JD271</b> ■ (Metal) <b>JD273</b> ■ MLS	<b>HL700</b> ■	<b>HR599</b> ■	<b>NA5053</b> 30.00x42.00x7.00mm FPM <b>NA5069</b> 55.00x68.00x8.00mm FPM
---	---	---	--	--	----------------	----------------	--



AY500



BW720

## 194

### 82.00

### Petrol



182 A2.000

4 Cyl.

10.3:1

1747cc

83kW (113)PS

TD4398

929

<b>TB468</b> 168x24 →08/00			<b>FOL106</b> (x16) Height: 24mm <b>FOL145</b> (x16) Height: 26mm

 B x C x D	OE	MAT.	 45°	 H	 E x F x G
<b>V91933</b> ■ 33.40 x 7.00 x 113.10	608 11 153	 MB cr	45°	H	<b>VAG96123</b> ■ 42.25 x 7.02 x 13.05
<b>V91934</b> ■ 28.00 x 7.00 x 108.60	608 11 154	 MD cr	45°	ss	<b>VAG96146</b> ■ 42.50 x 7.04 x 13.05
<b>V94582</b> ■ 28.00 x 7.00 x 108.50	7 766 565	 MD cr	45°		<b>VAG96145</b> ■ 46.00 x 7.02 x 13.03
<b>V94591</b> ■ 28.00 x 7.00 x 108.80	606 74 496	 MG cr	45°	ss H	<b>VAG96230</b> ■ 46.00 x 7.02 x 13.06

<b>BW720</b> Fibre Composite, 1.650mm <b>AY500</b> Fibre Composite, 1.85mm	<b>DW720</b> →06/99 <b>DW723</b> 07/99→	<b>GW724</b> →06/99	<b>HBS132</b> ☒ M10x1.25x254.00mm (x10)	<b>JD271</b> ■ (Metal) →06/99 <b>JA5007</b> ■ 07/99→ <b>JD273</b> ■ MLS	<b>HL701</b> ■	<b>HR800</b> ■	<b>NA5053</b> 30.00x42.00x7.00mm FPM <b>NA5069</b> 55.00x68.00x8.00mm FPM



AY500



BW720

## 195

 82.00

Petrol



182 A2.000

4 Cyl.







10:1







1747cc



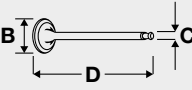

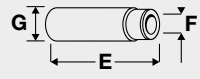

83kW (113)PS

TD9473

929

					
<b>TB468</b> 168x24 →10/98	<b>TBK356</b> →10/98 Component No: TB468; AE1147TP;AE1042TP				<b>FOL106</b> (x16) Height: 24mm

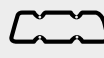
	OE	MAT.			
B x C x D					E x F x G
<b>V91933</b> ■ 33.40 x 7.00 x 113.10	608 11 153	 MB cr	45°	H	<b>VAG96123</b> ■ 42.25 x 7.02 x 13.05
<b>V91934</b> ■ 28.00 x 7.00 x 108.60	608 11 154	 MD cr	45°	ss	<b>VAG96146</b> ■ 42.50 x 7.04 x 13.05
<b>V94582</b> ■ 28.00 x 7.00 x 108.50	7 766 565	 MD cr	45°		<b>VAG96145</b> ■ 46.00 x 7.02 x 13.03
<b>V94591</b> ■ 28.00 x 7.00 x 108.80	606 74 496	 MG cr	45°	ss H	<b>VAG96230</b> ■ 46.00 x 7.02 x 13.06

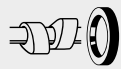
							
<b>BW720</b> Fibre Composite, 1.650mm <b>AY500</b> Fibre Composite, 1.85mm	<b>DW720</b>	<b>GW724</b>	<b>HBS132</b> ☒ M10x1.25x254.00mm (x10)	<b>JD271</b> ■ (Metal) <b>JD273</b> ■ MLS	<b>HL701</b> ■	<b>HR599</b> ■	<b>NA5053</b> 30.00x42.00x7.00mm FPM <b>NA5069</b> 55.00x68.00x8.00mm FPM



AY500



BW720

<b>196</b>	<b>82.00</b>	<b>Petrol</b>	
<b>183 A1.000</b>	4 Cyl.	10.3:1	1747cc
			<b>96kW (131)PS</b>
			<b>TD9474 930</b>

<b>TB468</b> 168x24	<b>TBK356</b> Component No: TB468; AE1147TP;AE1042TP		<b>KIT</b>		

	OE	MAT.				
B x C x D						E x F x G
<b>V91933</b> ■ 33.40 x 7.00 x 113.10	608 11 153	 MB cr	45°		H	<b>VAG96123</b> ■ 42.25 x 7.02 x 13.05
<b>V91934</b> ■ 28.00 x 7.00 x 108.60	608 11 154	 MD cr	45°	ss		<b>VAG96146</b> ■ 42.50 x 7.04 x 13.05
<b>V94582</b> ■ 28.00 x 7.00 x 108.50	7 766 565	 MD cr	45°			<b>VAG96145</b> ■ 46.00 x 7.02 x 13.03
<b>V94591</b> ■ 28.00 x 7.00 x 108.80	606 74 496	 MG cr	45°	ss	H	<b>VAG96230</b> ■ 46.00 x 7.02 x 13.06

<b>BW720</b> Fibre Composite, 1.650mm <b>AY500</b> Fibre Composite, 1.85mm	<b>DW723</b>	<b>GW723</b>	<b>HBS132</b> ☒ M10x1.25x254.00mm (x10)	<b>JD271</b> ■ (Metal) <b>JD273</b> ■ MLS	<b>HL701</b> ■	<b>HR599</b> ■	<b>NA5053</b> 30.00x42.00x7.00mm FPM <b>NA5069</b> 55.00x68.00x8.00mm FPM



AY500



BW720



183 A1.000

4 Cyl.

10.3:1

1747cc

92-97kW (125-132)PS

TD4405

929

<b>TB468</b> 168x24	<b>TBK356</b> Component No: TB468; AE1147TP;AE1042TP		<b>KIT</b>		<b>FOL106</b> (x16) Height: 24mm <b>FOL145</b> (x16) Height: 26mm

	OE	MAT.			
B x C x D					E x F x G
<b>V91933</b> ■ 33.40 x 7.00 x 113.10	608 11 153	 MB cr	45°	H	<b>VAG96123</b> ■ 42.25 x 7.02 x 13.05
<b>V91934</b> ■ 28.00 x 7.00 x 108.60	608 11 154	 MD cr	45°	ss	<b>VAG96146</b> ■ 42.50 x 7.04 x 13.05
<b>V94582</b> ■ 28.00 x 7.00 x 108.50	7 766 565	 MD cr	45°		<b>VAG96145</b> ■ 46.00 x 7.02 x 13.03
<b>V94591</b> ■ 28.00 x 7.00 x 108.80	606 74 496	 MG cr	45°	ss H	<b>VAG96230</b> ■ 46.00 x 7.02 x 13.06

<b>BW720</b> Fibre Composite, 1.650mm <b>AY500</b> Fibre Composite, 1.85mm	<b>DW723</b>	<b>GW723</b>	<b>HBS132</b> ☒ M10x1.25x254.00mm (x10)	<b>JD271</b> ■ (Metal) <b>JD273</b> ■ MLS	<b>HL701</b> ■	<b>HR800</b> ■	<b>NA5053</b> 30.00x42.00x7.00mm FPM <b>NA5069</b> 55.00x68.00x8.00mm FPM



AY500



BW720

## 198

## 82.00

## Petrol



188 A6.000

4 Cyl.

10.3:1

1747cc

96kW (130)PS

TD16408

931

<b>TB468</b> 168x24 →08/00	<b>TBK345</b> 09/00→10/05 Component No: TB559; AE1147TP;AE1100TP				<b>FOL106</b> (x16) Height: 24mm <b>FOL145</b> (x16) Height: 26mm

	OE	MAT.			
B x C x D					E x F x G
<b>V91933</b> ■ 33.40 x 7.00 x 113.10	608 11 153	 MB cr	45°	H	<b>VAG96123</b> ■ 42.25 x 7.02 x 13.05
<b>V91934</b> ■ 28.00 x 7.00 x 108.60	608 11 154	 MD cr	45°	ss	<b>VAG96146</b> ■ 42.50 x 7.04 x 13.05
<b>V94582</b> ■ 28.00 x 7.00 x 108.50	7 766 565	 MD cr	45°		<b>VAG96145</b> ■ 46.00 x 7.02 x 13.03
<b>V94591</b> ■ 28.00 x 7.00 x 108.80	606 74 496	 MG cr	45°	ss H	<b>VAG96230</b> ■ 46.00 x 7.02 x 13.06

<b>AA5420</b> MLS, 0.380mm	<b>CA5421</b>	<b>HBS132</b> ⊗ M10x1.25x254.00mm (x10)	<b>JD271</b> ■ (Metal) <b>JD273</b> ■ MLS	<b>HL701</b> ■	<b>HR800</b> ■	<b>NA5053</b> 30.00x42.00x7.00mm FPM <b>NA5069</b> 55.00x68.00x8.00mm FPM



AA5420



192 A4.000

4 Cyl.

10.3:1

1747cc

96-98kW (130-133)PS

TD16395

931

<b>TBK345</b> Component No: TB559; AE1147TP;AE1100TP		<b>FOL106</b> (x16) Height: 24mm <b>FOL145</b> (x16) Height: 26mm	

	OE	MAT.		
B x C x D				E x F x G
<b>V91933</b> ■ 33.40 x 7.00 x 113.10	608 11 153		45° H	<b>VAG96123</b> ■ 42.25 x 7.02 x 13.05
<b>V91934</b> ■ 28.00 x 7.00 x 108.60	608 11 154		45° ss	<b>VAG96146</b> ■ 42.50 x 7.04 x 13.05
<b>V94582</b> ■ 28.00 x 7.00 x 108.50	7 766 565		45°	<b>VAG96145</b> ■ 46.00 x 7.02 x 13.03
<b>V94591</b> ■ 28.00 x 7.00 x 108.80	606 74 496		45° ss H	<b>VAG96230</b> ■ 46.00 x 7.02 x 13.06

AA5420 MLS, 0.380mm	CA5421	HBS132 ☒ M10x1.25x254.00mm (x10)	JD271 ■ (Metal) JD273 ■ MLS	HL701 ■	HR800 ■	NA5053 30.00x42.00x7.00mm FPM NA5069 55.00x68.00x8.00mm FPM



AA5420



<b>200</b>	<b>82.00</b>	<b>Petrol</b>	
<b>839 A4.000</b>	4 Cyl.	1747cc	<b>96kW (131)PS</b>
			<b>TD14468 929</b>

<b>TB468</b> 168x24 →10/05			<b>FOL106</b> (x16) Height: 24mm <b>FOL145</b> (x16) Height: 26mm

 B x C x D	OE	MAT.				 E x F x G
<b>V91933</b> ■ 33.40 x 7.00 x 113.10	608 11 153	 MB cr	45°		H	<b>VAG96123</b> ■ 42.25 x 7.02 x 13.05
<b>V91934</b> ■ 28.00 x 7.00 x 108.60	608 11 154	 MD cr	45°	ss		<b>VAG96146</b> ■ 42.50 x 7.04 x 13.05
<b>V94582</b> ■ 28.00 x 7.00 x 108.50	7 766 565	 MD cr	45°			<b>VAG96145</b> ■ 46.00 x 7.02 x 13.03
<b>V94591</b> ■ 28.00 x 7.00 x 108.80	606 74 496	 MG cr	45°	ss	H	<b>VAG96230</b> ■ 46.00 x 7.02 x 13.06

<b>BW720</b> Fibre Composite, 1.650mm <b>AY500</b> Fibre Composite, 1.85mm	<b>DW723</b>	<b>GW723</b>	<b>HBS132</b> ☒ M10x1.25x254.00mm (x10)	<b>JA5007</b> ■ <b>JD273</b> ■ MLS	<b>HL701</b> ■	<b>HR599</b> ■	<b>NA5053</b> 30.00x42.00x7.00mm FPM <b>NA5069</b> 55.00x68.00x8.00mm FPM



AY500



BW720

# FIAT GROUP

## 201

82.00

Petrol



839 A7.000

4 Cyl.

10.3:1

1747cc

96kW (131)PS

TD15633

931



**TB468**  
168x24  
→10/05

**FOL106** (x16)  
Height: 24mm  
**FOL145** (x16)  
Height: 26mm

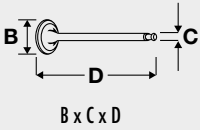

OE



MAT.

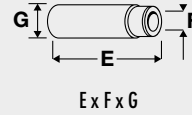

**V91933** ■  
33.40 x 7.00 x 113.10  
**V91934** ■  
28.00 x 7.00 x 108.60  
**V94582** ■  
28.00 x 7.00 x 108.50  
**V94591** ■  
28.00 x 7.00 x 108.80

608 11 153  
608 11 154  
7 766 565  
606 74 496

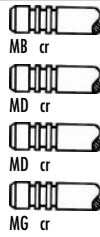

45°  
45° ss  
45°  
45° ss H

**VAG96123** ■  
42.25 x 7.02 x 13.05  
**VAG96146** ■  
42.50 x 7.04 x 13.05  
**VAG96145** ■  
46.00 x 7.02 x 13.03  
**VAG96230** ■  
46.00 x 7.02 x 13.06

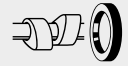
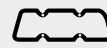
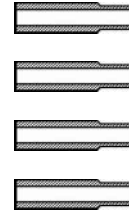

**AA5420** MLS, 0.380mm  
**BW720** Fibre Composite, 1.650mm  
**AY500** Fibre Composite, 1.85mm

**CA5421**  
**DW723**

**GW723**

**HBS132** ☒  
M10x1.25x254.00mm (x10)

**JA5007** ■  
**JD273** ■  
MLS

**HL701** ■

**HR599** ■

**NA5053**  
30.00x42.00x7.00mm FPM



AA5420, BW720

AY500

## 202

82.00

Petrol



839 A9.000

4 Cyl.

10.3:1

1747cc

96kW (131)PS

TD17508

932



**TB468**  
168x24  
→10/05

**FOL106** (x16)  
Height: 24mm  
**FOL145** (x16)  
Height: 26mm

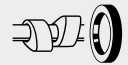
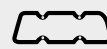

**AA5420** MLS, 0.380mm  
**BW720** Fibre Composite, 1.650mm  
**AY500** Fibre Composite, 1.85mm

**CA5421**  
**DW723**

**GW723**

**HBS132** ☒  
M10x1.25x254.00mm (x10)

**JA5007** ■  
**JD273** ■  
MLS

**HL701** ■

**HR599** ■







**NA5053**  
30.00x42.00x7.00mm FPM









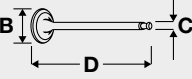
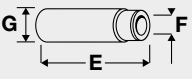
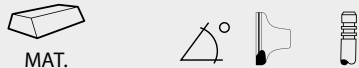

AA5420, BW720

AY500

<b>203</b>	 <b>82.00</b>	<b>Petrol</b>	
<b>AR 32201</b>	4 Cyl.	10.3:1	1747cc
			<b>106kW (144)PS</b>
			<b>TD9462 933</b>

					
<b>TB468</b> 168x24	<b>TBK356</b> Component No: TB468; AE1147TP;AE1042TP		<b>KIT</b>		<b>FOL106</b> (x16) Height: 24mm <b>FOL145</b> (x16) Height: 26mm

	
B x C x D	E x F x G
OE	
MAT.	
	
<b>V91933</b> ■ 33.40 x 7.00 x 113.10	<b>VAG96146</b> ■ 42.50 x 7.04 x 13.05
<b>V94591</b> ■ 28.00 x 7.00 x 108.80 01/02→	<b>VAG50895</b> ■ 46.00 x 7.04 x 13.03
<b>V91934</b> ■ 28.00 x 7.00 x 108.60	<b>VAG96230</b> ■ 46.00 x 7.02 x 13.06
608 11 153 606 74 496 608 11 154	
MB cr MG cr MD cr	
45° 45° 45°	
H ss ss	

							
<b>BW720</b> Fibre Composite, 1.650mm <b>AY500</b> Fibre Composite, 1.85mm	<b>DW722</b>	<b>GW721</b> →05/98 <b>GW722</b> 05/98→06/00	<b>HBS132</b> ☒ M10x1.25x254.00mm (x10)	<b>JD271</b> ■ (Metal) <b>JD273</b> ■ MLS	<b>JM5002</b> (Elastomer) <b>HL700</b> ■	<b>HR599</b> ■	<b>NA5053</b> 30.00x42.00x7.00mm FPM <b>NA5069</b> 55.00x68.00x8.00mm FPM



AY500



BW720





## 204





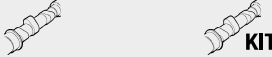

 82.00



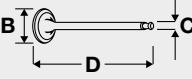

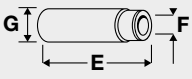

Petrol



AR 32205      4 Cyl.      1747cc      103kW (140)PS      TD15390      933

				
<b>TBK345</b> Component No: TB559; AE1147TP;AE1100TP				<b>FOL106</b> (x16) Height: 24mm <b>FOL145</b> (x16) Height: 26mm

	OE	MAT.		
B x C x D				E x F x G
<b>V91933</b> ■ 33.40 x 7.00 x 113.10	608 11 153	 MB cr	45° H	<b>VAG96146</b> ■ 42.50 x 7.04 x 13.05
<b>V94591</b> ■ 28.00 x 7.00 x 108.80 01/02 →	606 74 496	 MG cr	45° ss H	<b>VAG50895</b> ■ 46.00 x 7.04 x 13.03
<b>V91934</b> ■ 28.00 x 7.00 x 108.60	608 11 154	 MD cr	45° ss	<b>VAG96230</b> ■ 46.00 x 7.02 x 13.06

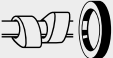
							
AA5420 MLS, 0.380mm	CA5420	HBS262 ☉ M10x1.25x220.00mm (x10)	JD271 ■ (Metal) JD273 ■ MLS	JM5002 (Elastomer)	HR599 ■	NA5053 30.00x42.00x7.00mm FPM NA5069 55.00x68.00x8.00mm FPM	



AA5420

## 205

## 82.00

## Petrol



AR 38401

4 Cyl.

10.3:1

1747cc

103kW (140)PS

TD9755

933

<b>TB468</b> 168x24 →02/99			<b>FOL106</b> (x16) Height: 24mm <b>FOL145</b> (x16) Height: 26mm

	OE	MAT.		
B x C x D				E x F x G
<b>V91933</b> ■ 33.40 x 7.00 x 113.10	608 11 153		45° H	<b>VAG96146</b> ■ 42.50 x 7.04 x 13.05
<b>V94591</b> ■ 28.00 x 7.00 x 108.80 01/02→	606 74 496		45° ss H	<b>VAG50895</b> ■ 46.00 x 7.04 x 13.03
<b>V91934</b> ■ 28.00 x 7.00 x 108.60	608 11 154		45° ss	<b>VAG96230</b> ■ 46.00 x 7.02 x 13.06

<b>BW720</b> Fibre Composite, 1.650mm <b>AY500</b> Fibre Composite, 1.85mm	<b>DW722</b>	<b>GW721</b> →05/98 <b>GW722</b> 05/98→06/00	<b>HBS132</b> ☒ M10x1.25x254.00mm (x10)	<b>JD271</b> ■ (Metal) <b>JD273</b> ■ MLS	<b>HL700</b> ■	<b>HR599</b> ■	<b>NA5053</b> 30.00x42.00x7.00mm FPM <b>NA5069</b> 55.00x68.00x8.00mm FPM



AY500

















BW720

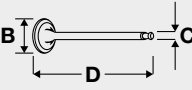
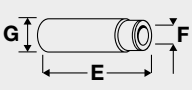





# FIAT GROUP

## 206 82.00 Petrol

AR 67106 4 Cyl. 10.3:1 1747cc 103kW (140)PS TD5070 933

					
<b>TB468</b> 168x24	<b>TBK356</b> Component No: TB468; AE1147TP;AE1042TP				<b>FOL106</b> (x16) Height: 24mm <b>FOL145</b> (x16) Height: 26mm



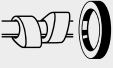

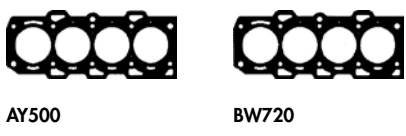

	
B x C x D	E x F x G
OE	
MAT.	
	
<b>V91933</b> ■	H
33.40 x 7.00 x 113.10	
	45° ss
<b>V94591</b> ■	H
28.00 x 7.00 x 108.80	
01/02 →	
	45° ss
<b>V91934</b> ■	
28.00 x 7.00 x 108.60	
	
	<b>VAG96146</b> ■
	42.50 x 7.04 x 13.05
	
	<b>VAG50895</b> ■
	46.00 x 7.04 x 13.03
	
	<b>VAG96230</b> ■
	46.00 x 7.02 x 13.06

							
<b>BW720</b> Fibre Composite, 1.650mm	<b>DW722</b>	<b>GW721</b>	<b>HBS132</b> ☒	<b>JD271</b> ■	<b>HL700</b> ■	<b>HR599</b> ■	<b>NA5053</b>
<b>AY500</b> Fibre Composite, 1.85mm		→05/98	M10x1.25x254.00mm (x10)	(Metal)			30.00x42.00x7.00mm FPM
		<b>GW722</b>		<b>JD273</b> ■			<b>NA5069</b>
		05/98 →06/00		MLS			55.00x68.00x8.00mm FPM



## 207 82.00 Petrol

AR 67199 4 Cyl. 10.3:1 1747cc 103kW (140)PS TD23350 934

					
<b>TB468</b> 168x24	<b>TBK356</b> Component No: TB468; AE1147TP;AE1042TP				<b>FOL106</b> (x16) Height: 24mm <b>FOL145</b> (x16) Height: 26mm

<b>208</b>	<b>82.00</b>	<b>Diesel</b>					
<b>182 A7.000</b>	4 Cyl.	20.7:1	1910cc	74kW (100)PS	<b>Turbo Intercooled</b>	<b>TD4403</b>	<b>936</b>

<b>TB608</b> 193x24 →08/00 <b>TB639</b> 190x24 08/00→	<b>TBK352</b> →08/00 Component No: TB608; AE1087GP;AE1041TP <b>TBK283</b> 05/03→ Component No: TB639; AE1041TP;AE1182GP <b>TBK104</b> 08/00→05/03 Component No: TB639; AE1041TP;AE1087GP	<b>CAM649</b>		<b>FOL104 (x8) [6]</b>

[6] Mechanical      [6] Mécanique      [6] Meccanico      [6] Mecánico

<b>V91937</b> ■ 37.50 x 8.00 x 114.20	<b>V91938</b> ■ 31.00 x 8.00 x 114.00	<b>VAG96124</b> ■ ■ 42.90 x 8.02 x 14.06	<b>VAG96203</b> ■ ■ 43.00 x 8.03 x 14.08	<b>VAG96210</b> ■ ■ 43.00 x 8.04 x 14.04

<b>BY410</b> Fibre Composite, 1.600mm →12/98 <b>BY420</b> Fibre Composite, 1.700mm, 1 Notch →12/98 <b>BY430</b> Fibre Composite, 1.800mm, 2 Notches →12/98 <b>BE440</b> MLS, 1.600mm 01/99→ <b>BE450</b> MLS, 1.700mm 01/99→ <b>BE460</b> MLS, 1.800mm 01/99→	<b>DY410</b> ▲	<b>GY411</b> ▲	<b>HBS227</b> ☼ M12x1.25x218.00mm (x10)	<b>JD467</b> ■ <b>JD468</b> ■ MLS	<b>JP019</b>	<b>HR363</b> ■	<b>NA5053</b> 30.00x42.00x7.00mm FPM	

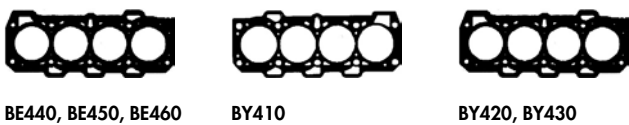

**BE440, BE450, BE460**      **BY410**      **BY420, BY430**

**182 A8.000**

4 Cyl.

20.7:1

1910cc

**55kW (75)PS**
**Turbo Intercooled**
**TD4404**
**936**

<b>TB608</b> 193x24 →08/00	<b>TBK094</b> →08/00 Component No: TB608; AE1041TP;AE1182GP	<b>CAM649</b>		<b>FOL104 (x8) [6]</b>

[6] Mechanical

[6] Mécanique

[6] Meccanico

[6] Mecánico

<b>V91937</b> ■ 37.50 x 8.00 x 114.20	<b>V91938</b> ■ 31.00 x 8.00 x 114.00	<b>VAG96124</b> ■ ■ ■ 42.90 x 8.02 x 14.06	<b>VAG96203</b> ■ ■ ■ 43.00 x 8.03 x 14.08	<b>VAG96210</b> ■ ■ ■ 43.00 x 8.04 x 14.04

<b>BY410</b> Fibre Composite, 1.600mm →12/98	<b>DY410</b> ▲	<b>GY411</b> ▲	<b>HBS227</b> ☉ M12x1.25x218.00mm (x10)	<b>JD467</b> ■ <b>JD468</b> ■ MLS	<b>JP019</b>	<b>HR363</b> ■	<b>NA5053</b> 30.00x42.00x7.00mm FPM

**BE440, BE450, BE460**

**BY410**

**BY420, BY430**



<b>210</b>	<b>82.00</b>	<b>Diesel</b>					
<b>182 B4.000</b>	4 Cyl.	18.45:1	1910cc	<b>77-79kW (105-107)PS</b>	<b>Turbo Intercooled</b>	<b>TD11168</b>	<b>937</b>

<b>TB639</b> 190x24	<b>TBK283</b> Eng.→4114649 Component No: TB639; AE1041TP;AE1182GP	<b>CAM651</b>		<b>FOL104 (x8) [6]</b>

[6] Mechanical      [6] Mécanique      [6] Meccanico      [6] Mecánico

	OE	MAT.			
B x C x D					E x F x G
<b>V94064</b> ■	608 14 605		45°	H	<b>VAG96124</b> ■ ■
35.50 x 8.00 x 115.00		MB cr			42.90 x 8.02 x 14.06
<b>V94470</b> ■	46 750 859		45°	H	<b>VAG96203</b> ■ ■
35.30 x 8.00 x 115.00		MG cr			43.00 x 8.03 x 14.08
<b>V94065</b> ■	608 14 604		45°		<b>VAG96210</b> ■ ■
34.50 x 8.00 x 115.00		MD cr			43.00 x 8.04 x 14.04
<b>V94471</b> ■	46 783 962		45°	H	
34.50 x 8.00 x 115.00		MG cr			
<b>V94590</b> ■			45°	ss H	
34.45 x 8.00 x 115.00		MG cr			

<b>AY520</b> MLS, 1.600mm, 0 Holes <b>AY530</b> MLS, 1.700mm, 1 Hole <b>AY540</b> MLS, 1.800mm, 2 Holes	<b>CY550</b> ▲	<b>FY550</b> ▲	<b>HBS227</b> Ⓢ M12x1.25x218.00mm (x10)	<b>JA5035</b> ■ 01/00→ <b>JD468</b> ■ MLS	<b>JP063</b>	<b>HR363</b> ■	<b>NA5053</b> 30.00x42.00x7.00mm FPM

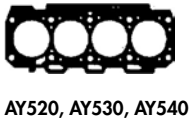



<b>TB608</b> 193x24 →08/00 <b>TB639</b> 190x24 08/00→	<b>TBK352</b> →08/00 Component No: TB608; AE1087GP;AE1041TP <b>TBK283</b> 05/03→ Component No: TB639; AE1041TP;AE1182GP <b>TBK104</b> 08/00→05/03 Component No: TB639; AE1041TP;AE1087GP	<b>CAM654</b>	<b>KIT</b>		<b>FOL104 (x8) [6]</b>

[6] Mechanical

[6] Mécanique

[6] Meccanico

[6] Mecánico

	OE	MAT.			
B x C x D					E x F x G
<b>V94064</b> ■ 35.50 x 8.00 x 115.00	608 14 605	 MB cr	45°	H	<b>VAG96124</b> ■ ■ ■ 42.90 x 8.02 x 14.06
<b>V94470</b> ■ 35.30 x 8.00 x 115.00	46 750 859	 MG cr	45°	H	<b>VAG96203</b> ■ ■ ■ 43.00 x 8.03 x 14.08
<b>V94065</b> ■ 34.50 x 8.00 x 115.00	608 14 604	 MD cr	45°		<b>VAG96210</b> ■ ■ ■ 43.00 x 8.04 x 14.04
<b>V94471</b> ■ 34.50 x 8.00 x 115.00	46 783 962	 MG cr	45°	H	
<b>V94590</b> ■ 34.45 x 8.00 x 115.00		 MG cr	45°	ss H	

<b>AA5561</b> MLS, 0.820mm, 0 Holes <b>AA5571</b> MLS, 0.920mm, 1 Hole <b>AA5581</b> MLS, 1.020mm, 2 Holes	<b>CA5560</b> ▲ →Eng.4081110 <b>CA5561</b> ▲ Eng.4081111→	<b>FA5560</b> ▲	<b>HBS227</b> ☒ M12x1.25x218.00mm (x10)	<b>JA5035</b> ■ <b>JD468</b> ■ MLS	<b>JM5028</b> (Elastomer) →Eng.4081110 <b>JM5204</b> (Elastomer) Eng.4081111→	<b>HR363</b> ■	<b>NA5053</b> 30.00x42.00x7.00mm FPM



AA5561



AA5571



AA5581

## 212

## 82.00

## Diesel



182 B9.000 Euro 3 (D3)

4 Cyl.

18.45:1

1910cc

74-77kW (101-105)PS

Turbo Intercooled

TD18312

938

<b>TB639</b> 190x24 →09/06	<b>TBK283</b> →09/06 Component No: TB639; AE1041TP;AE1182GP	<b>CAM654</b>	<b>KIT</b>	<b>FOL104 (x8) [6]</b>

[6] Mechanical

[6] Mécanique

[6] Meccanico

[6] Mecánico

B x C x D	E x F x G
<b>V94470</b> ■ 35.30 x 8.00 x 115.00	<b>VAG96124</b> ■ ■ ■ 42.90 x 8.02 x 14.06
<b>V94471</b> ■ 34.50 x 8.00 x 115.00	<b>VAG96203</b> ■ ■ ■ 43.00 x 8.03 x 14.08
<b>V94590</b> ■ 34.45 x 8.00 x 115.00	<b>VAG96210</b> ■ ■ ■ 43.00 x 8.04 x 14.04

<b>AA5561</b> MLS, 0.820mm, 0 Holes <b>AA5571</b> MLS, 0.920mm, 1 Hole <b>AA5581</b> MLS, 1.020mm, 2 Holes	<b>CA5560</b> ▲ →Eng.4081110 <b>CA5561</b> ▲ Eng.4081111→	<b>FA5560</b> ▲	<b>HBS227</b> ☒ M12x1.25x218.00mm (x10)	<b>JA5035</b> ■ <b>JD468</b> ■ MLS	<b>JM5028</b> (Elastomer) →Eng.4081110 <b>JM5204</b> (Elastomer) Eng.4081111→	<b>HR363</b> ■	<b>NA5053</b> 30.00x42.00x7.00mm FPM



AA5561



AA5571



AA5581



186 A6.000

4 Cyl.

18.45:1

1910cc

81kW (110)PS

Turbo Intercooled

TD15831

941

<b>TB639</b> 190x24	<b>TBK283</b> Eng.→4114649 Component No: TB639; AE1041TP;AE1182GP	<b>CAM651</b>		<b>FOL104 (x8) [6]</b>

[6] Mechanical [6] Mécanique [6] Meccanico [6] Mecánico

<b>V94064</b> ■ 35.50 x 8.00 x 115.00	<b>V94470</b> ■ 35.30 x 8.00 x 115.00	<b>V94065</b> ■ 34.50 x 8.00 x 115.00	<b>V94471</b> ■ 34.50 x 8.00 x 115.00	<b>V94590</b> ■ 34.45 x 8.00 x 115.00	<b>VAG96124</b> ■ ■ ■ 42.90 x 8.02 x 14.06	<b>VAG96203</b> ■ ■ ■ 43.00 x 8.03 x 14.08	<b>VAG96210</b> ■ ■ ■ 43.00 x 8.04 x 14.04
B x C x D	OE	MAT.	45°	H			
		MB cr					
		MG cr					
		MD cr					
		MG cr					
		MG cr	45°	ss			



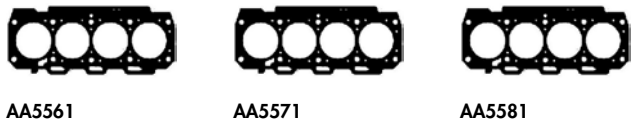



<b>AA5561</b> MLS, 0.820mm, 0 Holes →09/03	<b>CA5560</b> ▲ →Eng.4081110	<b>FA5560</b> ▲	<b>HBS227</b> ☒ M12x1.25x218.00mm (x10)	<b>JA5035</b> ■ <b>JD468</b> ■ MLS	<b>JM5028</b> (Elastomer) →Eng.4081110	<b>HR363</b> ■	<b>NA5053</b> 30.00x42.00x7.00mm FPM
<b>AA5571</b> MLS, 0.920mm, 1 Hole →09/03	<b>CA5561</b> ▲ Eng.4081111→				<b>JM5204</b> (Elastomer) Eng.4081111→		
<b>AA5581</b> MLS, 1.020mm, 2 Holes →09/03							







AA5561      AA5571      AA5581

**214**  **82.00** Diesel 

186 A8.000 4 Cyl. 1910cc 85kW (115)PS Turbo Intercooled TD18309 939

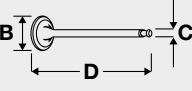
					
<b>TB639</b> 190x24	<b>TBK283</b> Eng.→4114649 Component No: TB639; AE1041TP;AE1182GP	<b>CAM651</b>			<b>FOL104</b> (x8) [6]

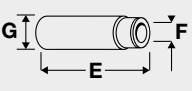
[6] Mechanical [6] Mécanique [6] Meccanico [6] Mecánico

	OE	MAT.			
<b>V94470</b> ■ 35.30 x 8.00 x 115.00	46 750 859		45°	H	<b>VAG96124</b> ■ ■ 42.90 x 8.02 x 14.06
<b>V94471</b> ■ 34.50 x 8.00 x 115.00	46 783 962		45°	H	<b>VAG96203</b> ■ ■ 43.00 x 8.03 x 14.08
					<b>VAG96210</b> ■ ■ 43.00 x 8.04 x 14.04

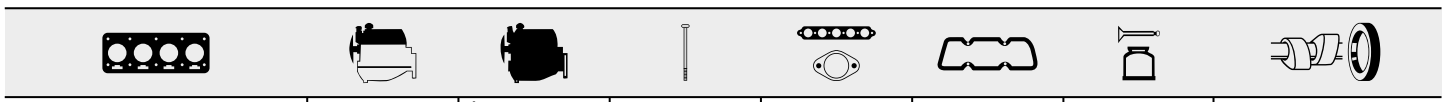



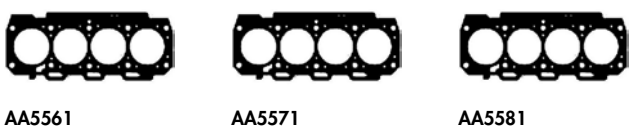



<b>AA5561</b> MLS, 0.820mm, 0 Holes <b>AA5571</b> MLS, 0.920mm, 1 Hole <b>AA5581</b> MLS, 1.020mm, 2 Holes	<b>CA5560</b> ▲ →Eng.4081110 <b>CA5561</b> ▲ Eng.4081111→	<b>FA5560</b> ▲	<b>HBS227</b> ☒ M12x1.25x218.00mm (x10)	<b>JA5035</b> ■ <b>JD468</b> ■ MLS	<b>JM5028</b> (Elastomer) →Eng.4081110 <b>JM5204</b> (Elastomer) Eng.4081111→	<b>HR363</b> ■	<b>NA5053</b> 30.00x42.00x7.00mm FPM
--	--	-----------------	--	--	--	----------------	---



**215**  **82.00** Diesel 

186 A9.000 4 Cyl. 1910cc 88kW (120)PS Turbo Intercooled TD19306 942

					
<b>TB639</b> 190x24	<b>TBK283</b> Component No: TB639; AE1041TP;AE1182GP	<b>CAM654</b>			<b>FOL104</b> (x8) [6]

[6] Mechanical [6] Mécanique [6] Meccanico [6] Mecánico

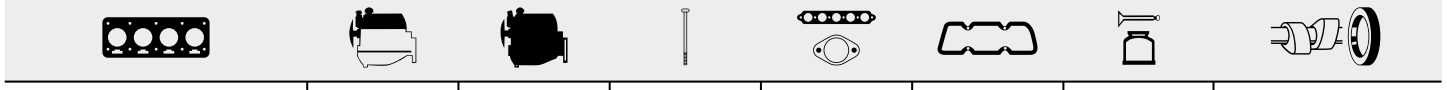

<b>AG7440</b> MLS <b>AG7390</b> MLS, 0.820mm <b>AG7400</b> MLS, 0.920mm, 1 Hole	<b>CA5561</b> ▲ <b>CG7490</b> ▲		<b>HBS227</b> ☒ M12x1.25x218.00mm (x10)	<b>JA5035</b> ■ <b>JD468</b> ■ MLS	<b>JM5204</b> (Elastomer)	<b>NA5053</b> 30.00x42.00x7.00mm FPM
---	------------------------------------	--	--	--	------------------------------	---

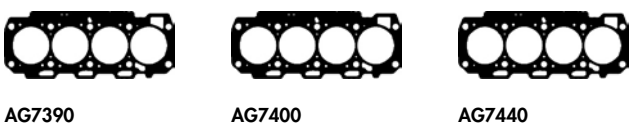



188 A2.000

4 Cyl.

18.4:1

1910cc

59kW (80)PS

Turbo Intercooled

TD12788

941

<b>TB639</b> 190x24 →08/05	<b>TBK283</b> →08/05 Component No: TB639; AE1041TP;AE1182GP	<b>CAM653</b>	<b>KIT</b>	<b>FOL104 (x8) [6]</b>

[6] Mechanical [6] Mécanique [6] Meccanico [6] Mecánico

	OE	MAT.			
<b>V94064</b> ■	608 14 605		45°	H	<b>VAG96124</b> ■ ■ ■
35.50 x 8.00 x 115.00					42.90 x 8.02 x 14.06
<b>V94470</b> ■	46 750 859		45°	H	<b>VAG96203</b> ■ ■ ■
35.30 x 8.00 x 115.00					43.00 x 8.03 x 14.08
<b>V94065</b> ■	608 14 604		45°		<b>VAG96210</b> ■ ■ ■
34.50 x 8.00 x 115.00					43.00 x 8.04 x 14.04
<b>V94471</b> ■	46 783 962		45°	H	
34.50 x 8.00 x 115.00					
<b>V94590</b> ■			45°	ss H	
34.45 x 8.00 x 115.00					

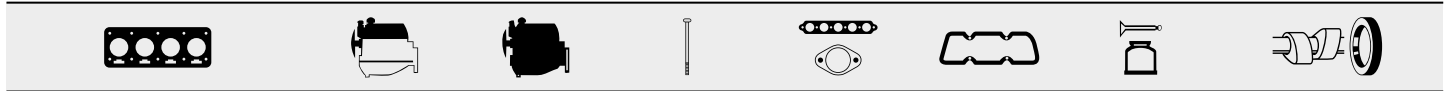

<b>AA5561</b> MLS, 0.820mm, 0 Holes →09/03	<b>CA5560</b> ▲ →Eng.4081110 <b>CA5561</b> ▲ Eng.4081111→	<b>FA5560</b> ▲	<b>HBS227</b> ☒ M12x1.25x218.00mm (x10)	<b>JA5035</b> ■ <b>JD468</b> ■ MLS	<b>JM5028</b> (Elastomer) →Eng.4081110 <b>JM5204</b> (Elastomer) Eng.4081111→	<b>HR363</b> ■	<b>NA5053</b> 30.00x42.00x7.00mm FPM
---	--	-----------------	--	--	--	----------------	---

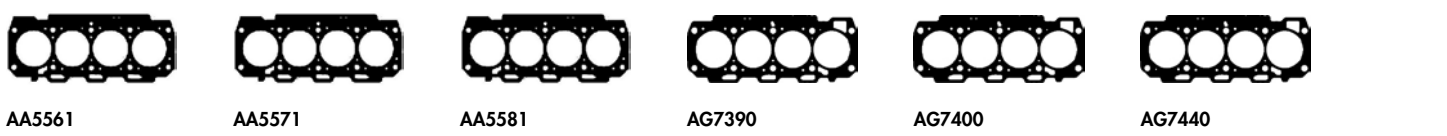

AA5561 AA5571 AA5581 AG7390 AG7400 AG7440

## 217

### 82.00

### Diesel



188 A3.000

4 Cyl.

22.5:1

1910cc

44kW (60)PS

TD12789

943

<b>TB608</b> 193x24 →10/03	<b>TBK094</b> →10/03 Component No: TB608; AE1041TP;AE1182GP	<b>CAM653</b>		<b>FOL104 (x8) [6]</b>

[6] Mechanical

[6] Mécanique

[6] Meccanico

[6] Mecánico

 B x C x D	OE	MAT.	 45°	 H	 E x F x G
<b>V94064</b> ■ 35.50 x 8.00 x 115.00	608 14 605	 MB cr	45°	H	<b>VAG96124</b> ■ ■ ■ 42.90 x 8.02 x 14.06
<b>V94470</b> ■ 35.30 x 8.00 x 115.00	46 750 859	 MG cr	45°	H	<b>VAG96203</b> ■ ■ ■ 43.00 x 8.03 x 14.08
<b>V94065</b> ■ 34.50 x 8.00 x 115.00	608 14 604	 MD cr	45°		<b>VAG96210</b> ■ ■ ■ 43.00 x 8.04 x 14.04
<b>V94471</b> ■ 34.50 x 8.00 x 115.00	46 783 962	 MG cr	45°	H	
<b>V94590</b> ■ 34.45 x 8.00 x 115.00		 MG cr	45°	ss H	

<b>BZ791</b> MLS, 0.800mm	<b>DZ790</b> ▲	<b>GZ790</b> ▲	<b>HBS227</b> Ⓢ M12x1.25x218.00mm (x10)	<b>JA5008</b> ■ (x4) (Elastomer) <b>JA5011</b> ■ (x4) (Elastomer) <b>JD468</b> ■ MLS	<b>JM5003</b> (Elastomer)	<b>HR363</b> ■	<b>NA5053</b> 30.00x42.00x7.00mm FPM



BZ791



BZ801



BZ811



188 A7.000

4 Cyl.

18.5:1

1910cc

63kW (86)PS

Turbo Intercooled

TD16409

941

<b>TB639</b> 190x24 09/01→10/05	<b>TBK283</b> 09/01→10/05 Component No: TB639; AE1041TP;AE1182GP	<b>CAM653</b>		<b>FOL104 (x8) [6]</b>

[6] Mechanical [6] Mécanique [6] Meccanico [6] Mecánico

B x C x D	E x F x G
<b>V94064</b> ■ 35.50 x 8.00 x 115.00	<b>VAG96124</b> ■ ■ ■ 42.90 x 8.02 x 14.06
<b>V94470</b> ■ 35.30 x 8.00 x 115.00	<b>VAG96203</b> ■ ■ ■ 43.00 x 8.03 x 14.08
<b>V94065</b> ■ 34.50 x 8.00 x 115.00	<b>VAG96210</b> ■ ■ ■ 43.00 x 8.04 x 14.04
<b>V94471</b> ■ 34.50 x 8.00 x 115.00	
<b>V94590</b> ■ 34.45 x 8.00 x 115.00	

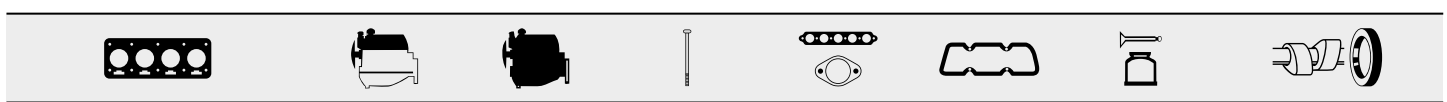

<b>AA5561</b> MLS, 0.820mm, 0 Holes →09/03	<b>CA5560</b> ▲ →Eng.4081110	<b>FA5560</b> ▲	<b>HBS227</b> ☒ M12x1.25x218.00mm (x10)	<b>JA5035</b> ■ <b>JD468</b> ■ MLS	<b>JM5028</b> (Elastomer) →Eng.4081110	<b>HR363</b> ■	<b>NA5053</b> 30.00x42.00x7.00mm FPM
<b>AA5571</b> MLS, 0.920mm, 1 Hole →09/03	<b>CA5561</b> ▲ Eng.4081111→				<b>JM5204</b> (Elastomer) Eng.4081111→		
<b>AA5581</b> MLS, 1.020mm, 2 Holes →09/03							
<b>AG7440</b> MLS 10/03→							
<b>AG7390</b> MLS, 0.820mm 10/03→							
<b>AG7400</b> MLS, 0.920mm, 1 Hole 10/03→							

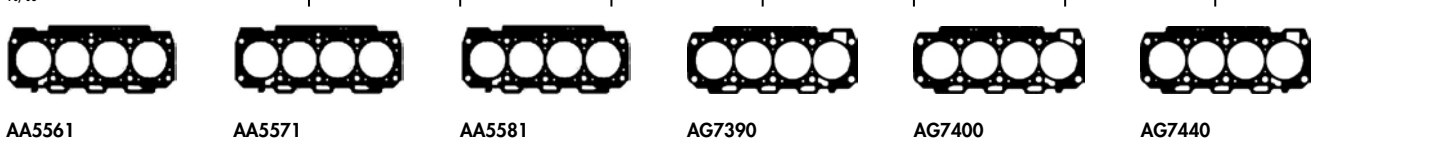

AA5561 AA5571 AA5581 AG7390 AG7400 AG7440









## 219

 **82.00**

**Diesel**



**188 B2.000**      4 Cyl.      18:1      1910cc      **74kW (101)PS**      **Turbo Intercooled**      **TD18316**      **944**

					
<b>TB639</b> 190x24	<b>TBK283</b> Component No: TB639; AE1041TP;AE1182GP	<b>CAM654</b>	<b>KIT</b>		<b>FOL104 (x8) [6]</b>

[6] Mechanical      [6] Mécanique      [6] Meccanico      [6] Mecánico

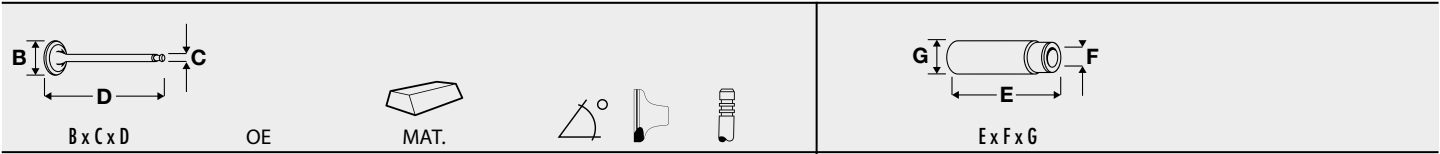

**VAG96210 III E**  
43.00 x 8.04 x 14.04

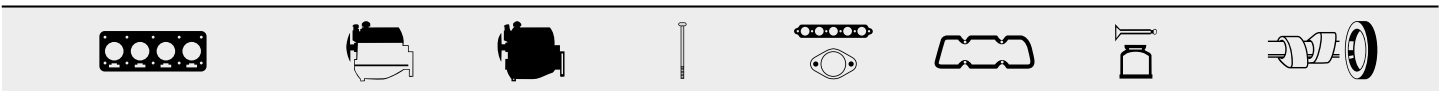
<p><b>AA5561</b> MLS, 0.820mm, 0 Holes →09/03</p> <p><b>AA5571</b> MLS, 0.920mm, 1 Hole →09/03</p> <p><b>AA5581</b> MLS, 1.020mm, 2 Holes →09/03</p> <p><b>AG7440</b> MLS 10/03 →</p> <p><b>AG7390</b> MLS, 0.820mm 10/03 →</p> <p><b>AG7400</b> MLS, 0.920mm, 1 Hole 10/03 →</p>	<p><b>CA5560</b> ▲ →Eng.4081110</p> <p><b>CA5561</b> ▲ Eng.4081111 →</p>	<p><b>FA5560</b> ▲</p>	<p><b>HBS227</b> ☒ M12x1.25x218.00mm (x10)</p>	<p><b>JA5035</b> ■ <b>JD468</b> ■ MLS</p>	<p><b>JM5028</b> (Elastomer) →Eng.4081110</p> <p><b>JM5204</b> (Elastomer) Eng.4081111 →</p>	<p><b>HR363</b> ■</p>	<p><b>NA5053</b> 30.00x42.00x7.00mm FPM</p>
---	--	------------------------	--	---	--	-----------------------	---



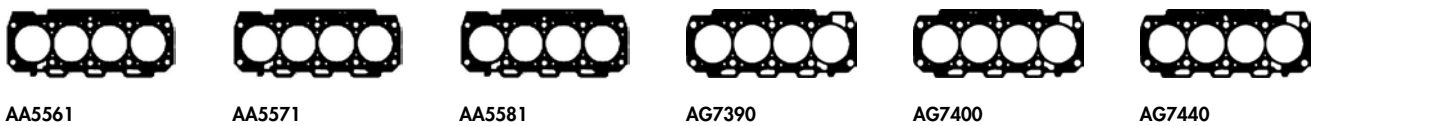

188 B2.000

4 Cyl.

18:1

1910cc

74kW (101)PS

Turbo Intercooled

TD18291

942



<b>TB639</b> 190x24 →10/05	<b>TBK283</b> →10/05 Component No: TB639; AE1041TP;AE1182GP	<b>CAM654</b>	<b>FOL104 (x8) [6]</b>
----------------------------------	--	---------------	------------------------

[6] Mechanical [6] Mécanique [6] Meccanico [6] Mecánico

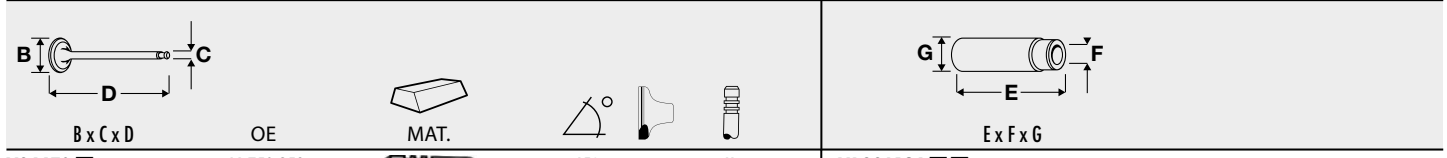

B x C x D	OE	MAT.	45°	H	E x F x G
<b>V94470</b> ■ 35.30 x 8.00 x 115.00	46 750 859	MG cr	45°	H	<b>VAG96124</b> ■ ■ ■ 42.90 x 8.02 x 14.06
<b>V94471</b> ■ 34.50 x 8.00 x 115.00	46 783 962	MG cr	45°	H	<b>VAG96203</b> ■ ■ ■ 43.00 x 8.03 x 14.08
					<b>VAG96210</b> ■ ■ ■ 43.00 x 8.04 x 14.04

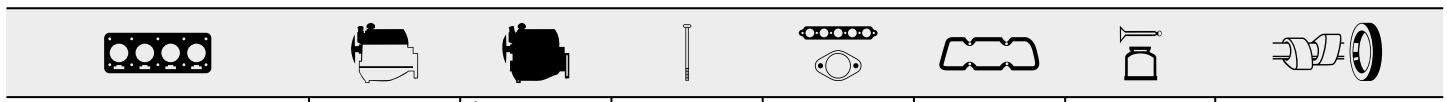

<b>AA5561</b> MLS, 0.820mm, 0 Holes →09/03	<b>CA5560</b> ▲ →Eng.4081110	<b>FA5560</b> ▲	<b>HBS227</b> ☉ M12x1.25x218.00mm (x10)	<b>JA5035</b> ■ <b>JD468</b> ■ MLS	<b>JM5028</b> (Elastomer) →Eng.4081110	<b>HR363</b> ■	<b>NA5053</b> 30.00x42.00x7.00mm FPM
<b>AA5571</b> MLS, 0.920mm, 1 Hole →09/03	<b>CA5561</b> ▲ Eng.4081111→				<b>JM5204</b> (Elastomer) Eng.4081111→		
<b>AA5581</b> MLS, 1.020mm, 2 Holes →09/03							
<b>AG7440</b> MLS 10/03→							
<b>AG7390</b> MLS, 0.820mm 10/03→							
<b>AG7400</b> MLS, 0.920mm, 1 Hole 10/03→							

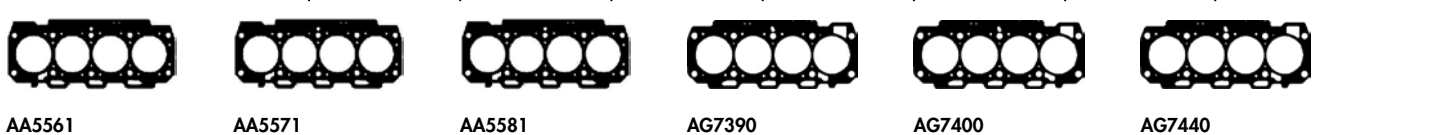

AA5561 AA5571 AA5581 AG7390 AG7400 AG7440







## 221

 **82.00**







**Diesel**

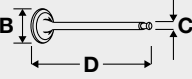

**192 A1.000**      4 Cyl.      18.5:1      1910cc      **85kW (115)PS**      **Turbo Intercooled**      **TD16398**      **945**

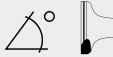
					
<b>TB639</b> 190x24	<b>TBK283</b> Component No: TB639; AE1041TP;AE1182GP	<b>CAM654</b>	<b>KIT</b>		<b>FOL104 (x8) [6]</b>

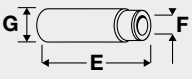
[6] Mechanical      [6] Mécanique      [6] Meccanico      [6] Mecánico

					
B x C x D	OE	MAT.	45°	H	E x F x G
<b>V94470</b> ■	46 750 859		45°	H	<b>VAG96124</b> ■ ■ ■
35.30 x 8.00 x 115.00		MG cr			42.90 x 8.02 x 14.06
<b>V94471</b> ■	46 783 962		45°	H	<b>VAG96203</b> ■ ■ ■
34.50 x 8.00 x 115.00		MG cr			43.00 x 8.03 x 14.08
					<b>VAG96210</b> ■ ■ ■
					43.00 x 8.04 x 14.04

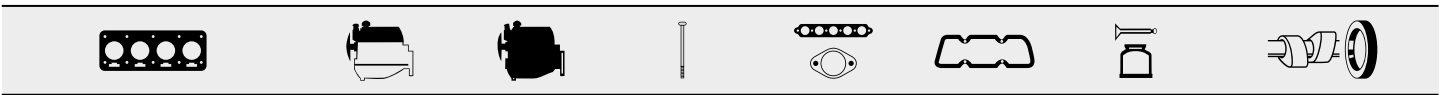

<b>AA5561</b> MLS, 0.820mm, 0 Holes →09/03	<b>CA5560</b> ▲ →Eng.4081110	<b>FA5560</b> ▲	<b>HBS227</b> ⊗ M12x1.25x218.00mm (x10)	<b>JA5035</b> ■ <b>JD468</b> ■ MLS	<b>JM5028</b> (Elastomer) →Eng.4081110 <b>JM5204</b> (Elastomer) Eng.4081111→	<b>HR363</b> ■	<b>NA5053</b> 30.00x42.00x7.00mm FPM
---	---------------------------------	-----------------	--	--	--	----------------	---



**AA5561**      **AA5571**      **AA5581**      **AG7390**      **AG7400**      **AG7440**



192 A3.000

4 Cyl.

18.5:1

1910cc

59kW (80)PS

Turbo Intercooled

TD16397

941

<b>TB639</b> 190x24	<b>TBK283</b> Component No: TB639; AE1041TP;AE1182GP	<b>CAM654</b>		<b>FOL104 (x8) [6]</b>

[6] Mechanical [6] Mécanique [6] Meccanico [6] Mecánico

	OE	MAT.			
B x C x D					E x F x G
<b>V94064</b>	608 14 605		45°	H	<b>VAG96124</b>
35.50 x 8.00 x 115.00		MB cr			42.90 x 8.02 x 14.06
<b>V94470</b>	46 750 859		45°	H	<b>VAG96203</b>
35.30 x 8.00 x 115.00		MG cr			43.00 x 8.03 x 14.08
<b>V94065</b>	608 14 604		45°		<b>VAG96210</b>
34.50 x 8.00 x 115.00		MD cr			43.00 x 8.04 x 14.04
<b>V94471</b>	46 783 962		45°	H	
34.50 x 8.00 x 115.00		MG cr			
<b>V94590</b>			45°	ss H	
34.45 x 8.00 x 115.00		MG cr			

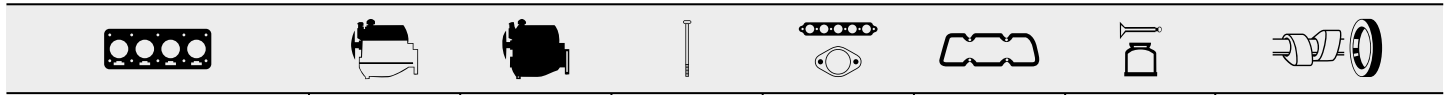

<b>AA5561</b> MLS, 0.820mm, 0 Holes →09/03	<b>CA5560</b> →Eng.4081110	<b>FA5560</b>	<b>HBS227</b> M12x1.25x218.00mm (x10)	<b>JA5035</b> <b>JD468</b> MLS	<b>JM5028</b> (Elastomer) →Eng.4081110	<b>HR363</b>	<b>NA5053</b> 30.00x42.00x7.00mm FPM
<b>AA5571</b> MLS, 0.920mm, 1 Hole →09/03	<b>CA5561</b> Eng.4081111→				<b>JM5204</b> (Elastomer) Eng.4081111→		
<b>AA5581</b> MLS, 1.020mm, 2 Holes →09/03	<b>CG7390</b> 10/03→						
<b>AG7440</b> MLS 10/03→							
<b>AG7390</b> MLS, 0.820mm 10/03→							
<b>AG7400</b> MLS, 0.920mm, 1 Hole 10/03→							

AA5561

AA5571

AA5581

AG7390

AG7400

AG7440

## 223

## 82.00

## Diesel



192 A5.000	4 Cyl.	18.5:1	1910cc	103kW (140)PS	Turbo Intercooled	TD17980	946
192 B1.000	4 Cyl.	18.5:1	1910cc	100kW (136)PS	Turbo Intercooled	TD18944	946

<b>TB725</b> 198x24	<b>TBK350</b> Component No: TB725; AEI182GP;AEI041TP				<b>FOL187</b> (x16)

	OE	MAT.			
B x C x D					E x F x G
<b>V94588</b> ■ 27.90 x 6.00 x 114.00 →06/06	46 802 049	 MB cr	45°	Y H	
<b>V98005</b> ■ 28.00 x 5.00 x 114.40 07/06→	55206431	 MB cr	45°		
<b>V94589</b> ■ 25.80 x 6.00 x 114.30 →06/06	46 787 902	 MG cr	45°	H	
<b>V98006</b> ■ 24.50 x 5.00 x 114.40 07/06→	55205183	 MG cr	45°		

<b>AD5840</b> MLS, 0.820mm, 0 Holes	<b>CD5840</b> ▲	<b>HBS370</b> ⊗ M12x1.25x225.00mm (x10)	<b>JD5376</b> ■	<b>JM7055</b> (Steel Elastomer)	<b>HR5095</b> ■	<b>NA5053</b> 30.00x42.00x7.00mm FPM

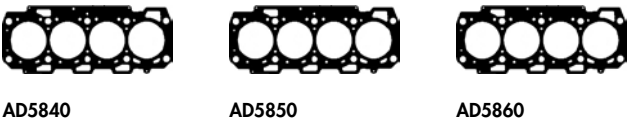

AD5840

AD5850

AD5860

# FIAT GROUP

## 224



82.00

Diesel



192 A5.000 Euro 3 (D3)	4 Cyl.	18.5:1	1910cc	103kW (140)PS	Turbo Intercooled	TD17981	946
192 B1.000	4 Cyl.	18.5:1	1910cc	100kW (136)PS	Turbo Intercooled	TD19061	946

<b>TB725</b> 198x24	<b>TBK350</b> Component No: TB725; AE1182GP;AE1041TP		<b>KIT</b>		<b>FOL187</b> (x16)

B x C x D	E x F x G					
<b>V94588</b> ■ 27.90 x 6.00 x 114.00	46 802 049		<b>MAT.</b>	45°	Y	H
<b>V94589</b> ■ 25.80 x 6.00 x 114.30	46 787 902		<b>MAT.</b>	45°		H

<b>AD5840</b> MLS, 0.820mm, 0 Holes <b>AD5850</b> MLS, 0.920mm, 1 Hole <b>AD5860</b> MLS, 1.020mm, 2 Holes	<b>CD5840</b> ▲	<b>HBS370</b> ☒ M12x1.25x225.00mm (x10)	<b>JD5376</b> ■	<b>JM7055</b> (Steel Elastomer)	<b>HR5095</b> ■	<b>NA5053</b> 30.00x42.00x7.00mm FPM
<b>AD5840</b>	<b>AD5850</b>	<b>AD5860</b>				

## 225



82.00

Diesel



192 A8.000	4 Cyl.	1910cc	88kW (120)PS	Turbo Intercooled	TD20238	947
------------	--------	--------	--------------	-------------------	---------	-----

<b>TB639</b> 190x24	<b>TBK283</b> Component No: TB639; AE1041TP;AE1182GP	<b>CAM654</b>			<b>FOL104</b> (x8) [6]
[6] Mechanical	[6] Mécanique	[6] Meccanico	[6] Mecánico		

B x C x D	E x F x G				
<b>V94470</b> ■ 35.30 x 8.00 x 115.00	46 750 859		<b>MAT.</b>	45°	H
<b>V94471</b> ■ 34.50 x 8.00 x 115.00	46 783 962		<b>MAT.</b>	45°	H
					<b>VAG96124</b> ■ ■ ■ 42.90 x 8.02 x 14.06
					<b>VAG96203</b> ■ ■ ■ 43.00 x 8.03 x 14.08
					<b>VAG96210</b> ■ ■ ■ 43.00 x 8.04 x 14.04

<b>AG7440</b> MLS <b>AG7390</b> MLS, 0.820mm <b>AG7400</b> MLS, 0.920mm, 1 Hole	<b>CA5561</b> ▲ <b>CG7390</b> ▲	<b>HBS227</b> ☒ M12x1.25x218.00mm (x10)				<b>NA5053</b> 30.00x42.00x7.00mm FPM
<b>AG7390</b>	<b>AG7400</b>	<b>AG7440</b>				

<b>226</b>	<b>82.00</b>	<b>Diesel</b>					
<b>192 A9.000</b>	4 Cyl.	18.45:1	1910cc	<b>74kW (100)PS</b>	<b>Turbo Intercooled</b>	<b>TD18451</b>	<b>948</b>
<b>TB639</b> 190x24		<b>CAM654</b>				<b>FOL104 (x8) [6]</b>	
[6] Mechanical	[6] Mécanique	[6] Meccanico	[6] Mecánico				

<b>B x C x D</b>	<b>E x F x G</b>
<b>OE</b>	
<b>MAT.</b>	
<b>V94470</b> ■	<b>VAG96124</b> ■ ■
35.30 x 8.00 x 115.00	42.90 x 8.02 x 14.06
<b>V94471</b> ■	<b>VAG96203</b> ■ ■
34.50 x 8.00 x 115.00	43.00 x 8.03 x 14.08
	<b>VAG96210</b> ■ ■
	43.00 x 8.04 x 14.04

<b>AG7440</b> MLS	<b>CA5560</b> ▲	<b>HBS227</b> ⊗	<b>JD468</b> ■	<b>JM5028</b>	<b>HR363</b> ■	<b>NA5053</b>
<b>AG7390</b> MLS, 0.820mm	→Eng.4081110	M12x1.25x218.00mm (x10)	MLS	(Elastomer)		30.00x42.00x7.00mm FPM
<b>AG7400</b> MLS, 0.920mm, 1 Hole	<b>CA5561</b> ▲			→Eng.4081110		
	Eng.4081111→			<b>JM5204</b>		
				(Elastomer)		
				Eng.4081111→		
<b>AG7390</b>	<b>AG7400</b>	<b>AG7440</b>				

<b>227</b>	<b>82.00</b>	<b>Diesel</b>					
<b>192 B4.000</b>	4 Cyl.	18:1	1910cc	<b>85kW (116)PS</b>	<b>Turbo Intercooled</b>	<b>TD24592</b>	<b>949</b>
<b>939 A7.000</b>	4 Cyl.		1910cc	<b>85kW (115)PS</b>	<b>Turbo Intercooled</b>	<b>TD20263</b>	<b>960</b>
<b>AG7440</b> MLS	<b>CG7390</b> ▲	<b>HBS227</b> ⊗	<b>JD468</b> ■	<b>JM5204</b>	<b>HR363</b> ■	<b>NA5053</b>	
<b>AG7390</b> MLS, 0.820mm		M12x1.25x218.00mm (x10)	MLS	(Elastomer)		30.00x42.00x7.00mm FPM	
<b>AG7400</b> MLS, 0.920mm, 1 Hole							
<b>AG7390</b>	<b>AG7400</b>	<b>AG7440</b>					

# FIAT GROUP

**228**



**82.00**

**Diesel**



192 B5.000

4 Cyl.

1910cc

66kW (90)PS

Turbo Intercooled

TD19308

948

<b>TB639</b> 190x24	<b>TBK283</b> Component No: TB639; AE1041TP;AE1182GP	<b>CAM653</b>			<b>FOL104 (x8) [6]</b>

[6] Mechanical

[6] Mécanique

[6] Meccanico

[6] Mecánico

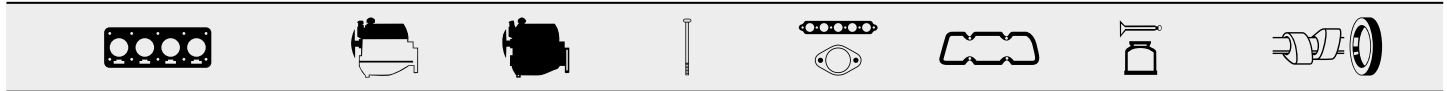

<b>AG7440</b> MLS <b>AG7390</b> MLS, 0.820mm <b>AG7400</b> MLS, 0.920mm, 1 Hole	<b>CG7390</b> ▲	<b>HBS227</b> ☼ M12x1.25x218.00mm (x10)	<b>JD468</b> ☒ MLS	<b>JM5204</b> (Elastomer)	<b>HR363</b> ☒	<b>NA5053</b> 30.00x42.00x7.00mm FPM
---	-----------------	--	-----------------------	------------------------------	----------------	---



AG7390

AG7400

AG7440

**229**



**82.00**

**Diesel**



199 A5.000

4 Cyl.

18:1

1910cc

96kW (131)PS

Turbo Intercooled

TD20762

950

<b>TB639</b> 190x24	<b>TBK283</b> Component No: TB639; AE1041TP;AE1182GP	<b>CAM654</b>			<b>FOL104 (x8) [6]</b>

[6] Mechanical

[6] Mécanique

[6] Meccanico

[6] Mecánico

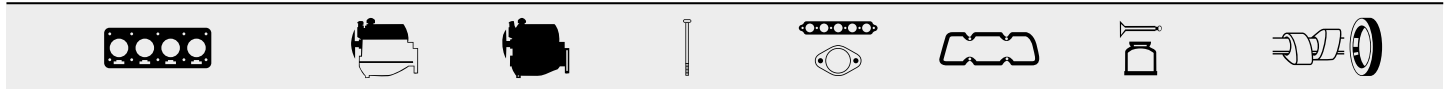

<b>AG7440</b> MLS <b>AG7390</b> MLS, 0.820mm <b>AG7400</b> MLS, 0.920mm, 1 Hole	<b>CG7390</b> ▲	<b>HBS227</b> ☼ M12x1.25x218.00mm (x10)	<b>JD468</b> ☒ MLS	<b>JM5204</b> (Elastomer)	<b>HR363</b> ☒	<b>NA5053</b> 30.00x42.00x7.00mm FPM
---	-----------------	--	-----------------------	------------------------------	----------------	---



AG7390

AG7400

AG7440



## 230

## 82.00

## Diesel



223 A6.000 Euro 3 (D3)

4 Cyl.

22.6:1

1910cc

46-48kW (63-65)PS

TD15829

951

<b>TB608</b> 193x24	<b>TBK352</b> Eng.→3646771 Component No: TB608; AE1087GP;AE1041TP <b>TBK094</b> Eng.3646772→ Component No: TB608; AE1041TP;AE1182GP	<b>CAM653</b>	<b>FOL104 (x8) [6]</b>

[6] Mechanical

[6] Mécanique

[6] Meccanico

[6] Mecánico

 B x C x D	OE	MAT.			 E x F x G
<b>V94064</b> ■■ 35.50 x 8.00 x 115.00	608 14 605	 MB cr	45°	H	<b>VAG96124</b> ■■ ■ 42.90 x 8.02 x 14.06
<b>V94470</b> ■■ 35.30 x 8.00 x 115.00	46 750 859	 MG cr	45°	H	<b>VAG96203</b> ■■ ■ 43.00 x 8.03 x 14.08
<b>V94065</b> ■ 34.50 x 8.00 x 115.00	608 14 604	 MD cr	45°		<b>VAG96210</b> ■■ ■ 43.00 x 8.04 x 14.04
<b>V94471</b> ■ 34.50 x 8.00 x 115.00	46 783 962	 MG cr	45°	H	
<b>V94590</b> ■ 34.45 x 8.00 x 115.00		 MG cr	45°	ss H	

<b>BZ791</b> MLS, 0.800mm <b>BZ801</b> MLS, 0.900mm, 1 Notch <b>BZ811</b> MLS, 1.0mm, 2 Notches	<b>DZ790</b> ▲	<b>GZ790</b> ▲	<b>HBS227</b> ☉ M12x1.25x218.00mm (x10)	<b>JA5011</b> ■ (x4) (Elastomer) <b>JD468</b> ■ MLS	<b>JM5003</b> (Elastomer)	<b>HR363</b> ■	<b>NA5053</b> 30.00x42.00x7.00mm FPM



BZ791



BZ801



BZ811

# FIAT GROUP

## 231



82.00

Diesel



223 A7.000

4 Cyl.

18.5:1

1910cc

77kW (105)PS

Turbo Intercooled

TD18318

942

<b>TB639</b> 190x24	<b>TBK283</b> Component No: TB639; AE1041TP;AE1182GP	<b>CAM654</b>	<b>KIT</b>		<b>FOL104 (x8) [6]</b>

[6] Mechanical

[6] Mécanique

[6] Meccanico

[6] Mecánico

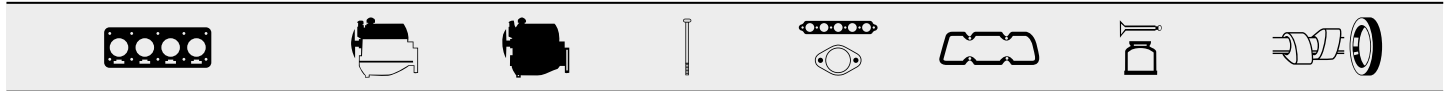

<b>AA5561</b> MLS, 0.820mm, 0 Holes →09/03	<b>CA5560</b> ▲ →Eng.4081110	<b>FA5560</b> ▲ →Eng.4081110	<b>HBS227</b> ☉ M12x1.25x218.00mm (x10)	<b>JA5035</b> ■ <b>JD468</b> ■ MLS	<b>JM5028</b> (Elastomer) →Eng.4081110 <b>JM5204</b> (Elastomer) Eng.4081111→	<b>HR363</b> ■	<b>NA5053</b> 30.00x42.00x7.00mm FPM
---	---------------------------------	---------------------------------	--	--	--	----------------	---

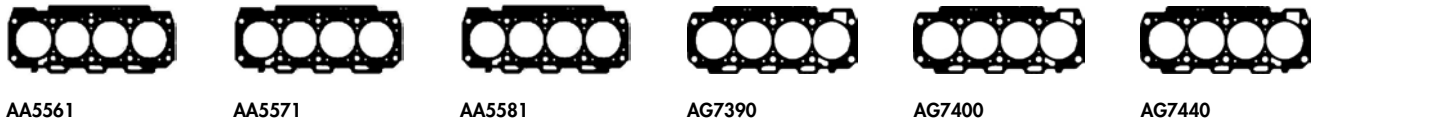

AA5561

AA5571

AA5581

AG7390

AG7400

AG7440

## 232



82.00

Diesel



223 B1.000

4 Cyl.

18.5:1

1910cc

77kW (105)PS

Turbo Intercooled

TD20245

938

<b>TB639</b> 190x24	<b>TBK283</b> Component No: TB639; AE1041TP;AE1182GP		<b>KIT</b>		

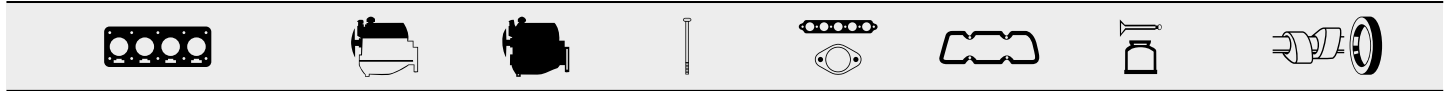

<b>AA5561</b> MLS, 0.820mm, 0 Holes →09/03	<b>CA5560</b> ▲ →Eng.4081110	<b>FA5560</b> ▲ →Eng.4081110	<b>HBS227</b> ☉ M12x1.25x218.00mm (x10)	<b>JA5035</b> ■ <b>JD468</b> ■ MLS	<b>JM5028</b> (Elastomer) →Eng.4081110 <b>JM5204</b> (Elastomer) Eng.4081111→	<b>HR363</b> ■	<b>NA5053</b> 30.00x42.00x7.00mm FPM
---	---------------------------------	---------------------------------	--	--	--	----------------	---

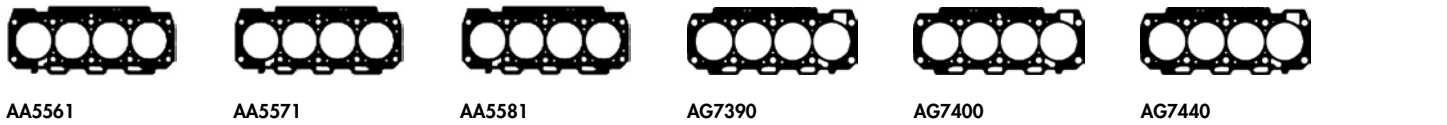

AA5561

AA5571

AA5581

AG7390

AG7400

AG7440

<b>233</b>	<b>82.00</b>	<b>Diesel</b>					
<b>223 B2.000</b>	4 Cyl.	18.5:1	1910cc	<b>74kW (100)PS</b>	<b>Turbo Intercooled</b>	<b>TD20246</b>	<b>938</b>
<b>TB639</b> 190x24	<b>TBK104</b> →05/03 Component No: TB639; AE1041TP;AE1087GP <b>TBK283</b> 05/03→ Component No: TB639; AE1041TP;AE1182GP					<b>FOL104 (x8) [6]</b>	

[6] Mechanical      [6] Mécanique      [6] Meccanico      [6] Mecánico

<b>AA5561</b> MLS, 0.820mm, 0 Holes →09/03 <b>AA5571</b> MLS, 0.920mm, 1 Hole →09/03 <b>AA5581</b> MLS, 1.020mm, 2 Holes →09/03 <b>AG7440</b> MLS 10/03→ <b>AG7390</b> MLS, 0.820mm 10/03→ <b>AG7400</b> MLS, 0.920mm, 1 Hole 10/03→	<b>CA5560</b> ▲ →Eng.4081110 <b>CA5561</b> ▲ Eng.4081111→	<b>FA5560</b> ▲ →Eng.4081110	<b>HBS227</b> ☒ M12x1.25x218.00mm (x10)	<b>JA5035</b> ■ <b>JD468</b> ■ MLS	<b>JM5028</b> (Elastomer) →Eng.4081110 <b>JM5204</b> (Elastomer) Eng.4081111→	<b>HR363</b> ■	<b>NA5053</b> 30.00x42.00x7.00mm FPM
<b>AA5561</b>	<b>AA5571</b>	<b>AA5581</b>	<b>AG7390</b>	<b>AG7400</b>	<b>AG7440</b>		

<b>234</b>	<b>82.00</b>	<b>Diesel</b>					
<b>844 A1.000</b>	4 Cyl.	16.1:1	1910cc	<b>140kW (190)PS</b>	<b>Bi-Turbocharged Intercooled</b>	<b>TD21044</b>	<b>952</b>
						<b>FOL187 (x16)</b>	



937 A2.000

4 Cyl.

1910cc

85kW (116)PS

Turbo Intercooled

TD18313

953

<b>TB639</b> 190x24 →10/05	<b>TBK283</b> →10/05 Component No: TB639; AE1041TP;AE1182GP	<b>CAM654</b>		<b>FOL104 (x8) [6]</b>

[6] Mechanical      [6] Mécanique      [6] Meccanico      [6] Mecánico

	OE	MAT.	Angle	Material	
B x C x D					E x F x G
<b>V94064</b> ■	608 14 605		45°	H	<b>VAG96124</b> ■ ■ ■
35.50 x 8.00 x 115.00		MB cr			42.90 x 8.02 x 14.06
<b>V94470</b> ■	46 750 859		45°	H	<b>VAG96203</b> ■ ■ ■
35.30 x 8.00 x 115.00		MG cr			43.00 x 8.03 x 14.08
<b>V94065</b> ■	608 14 604		45°		<b>VAG96210</b> ■ ■ ■
34.50 x 8.00 x 115.00		MD cr			43.00 x 8.04 x 14.04
<b>V94471</b> ■	46 783 962		45°	H	
34.50 x 8.00 x 115.00		MG cr			
<b>V94590</b> ■			45°	ss H	
34.45 x 8.00 x 115.00		MG cr			

<b>AA5561</b> MLS, 0.820mm, 0 Holes	<b>CA5560</b> ▲ →Eng.4081110	<b>FA5560</b> ▲ →Eng.4081110	<b>HBS227</b> ☒ M12x1.25x218.00mm (x10)	<b>JA5035</b> ■ <b>JD468</b> ■ MLS	<b>JM5028</b> (Elastomer) →Eng.4081110	<b>HR363</b> ■	<b>NA5053</b> 30.00x42.00x7.00mm FPM
<b>AA5571</b> MLS, 0.920mm, 1 Hole	<b>CA5561</b> ▲ Eng.4081111→				<b>JM5204</b> (Elastomer) Eng.4081111→		
<b>AA5581</b> MLS, 1.020mm, 2 Holes							

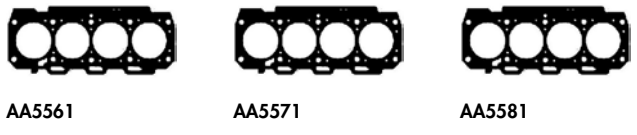

AA5561

AA5571

AA5581

## 236

## 82.00

## Diesel



937 A2.000

4 Cyl.

18.45:1

1910cc

85kW (115)PS

Turbo Intercooled

TD16382

954

<b>TB639</b> 190x24	<b>TBK283</b> Component No: TB639; AE1041TP;AE1182GP	<b>CAM654</b>	<b>KIT</b>	<b>FOL104 (x8) [6]</b>

[6] Mechanical

[6] Mécanique

[6] Meccanico

[6] Mecánico

	OE	MAT.			
B x C x D					E x F x G
<b>V94064</b> ■ 35.50 x 8.00 x 115.00 →12/00	608 14 605	 MB cr	45°	H	<b>VAG96203</b> ■ ■ 43.00 x 8.03 x 14.08
<b>V94470</b> ■ 35.30 x 8.00 x 115.00 01/01→	46 750 859	 MG cr	45°	H	<b>VAG96210</b> ■ ■ 43.00 x 8.04 x 14.04
<b>V94065</b> ■ 34.50 x 8.00 x 115.00	608 14 604	 MD cr	45°		
<b>V94471</b> ■ 34.50 x 8.00 x 115.00	46 783 962	 MG cr	45°	H	
<b>V94590</b> ■ 34.45 x 8.00 x 115.00		 MG cr	45°	ss H	

<b>AA5561</b> MLS, 0.820mm, 0 Holes <b>AA5571</b> MLS, 0.920mm, 1 Hole <b>AA5581</b> MLS, 1.020mm, 2 Holes	<b>CA5560</b> ▲ →Eng.4081110 <b>CA5561</b> ▲ Eng.4081111→	<b>FA5560</b> ▲ →Eng.4081110	<b>HBS227</b> Ⓢ M12x1.25x218.00mm (x10)	<b>JA5035</b> ■ (Metal) <b>JD468</b> ■ MLS	<b>JM5028</b> (Elastomer) →Eng.4081110 <b>JM5204</b> (Elastomer) Eng.4081111→	<b>HR363</b> ■	<b>NA5053</b> 30.00x42.00x7.00mm FPM



AA5561



AA5571



AA5581

# FIAT GROUP

## 237



82.00

Diesel



937 A3.000

4 Cyl.

1910cc

88kW (120)PS

Turbo Intercooled

TD20727

948



KIT



**TB639**  
190x24

**TBK283**  
Component No: TB639;  
AE1041TP;AE1182GP

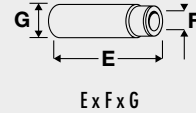
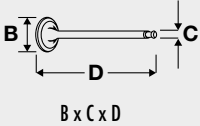

B x C x D	OE	MAT.	Angle	Height
<b>V94470</b> ■ 35.30 x 8.00 x 115.00	46 750 859	MG cr	45°	H
<b>V94065</b> ■ 34.50 x 8.00 x 115.00	608 14 604	MD cr	45°	
<b>V94471</b> ■ 34.50 x 8.00 x 115.00	46 783 962	MG cr	45°	H

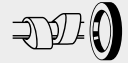
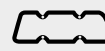

**AA5561** MLS, 0.820mm, 0 Holes  
**AA5571** MLS, 0.920mm, 1 Hole  
**AA5581** MLS, 1.020mm, 2 Holes

**CA5560** ▲  
→Eng.4081110  
**CA5561** ▲  
Eng.4081111→

**FA5560** ▲  
→Eng.4081110

**HBS227** ☒  
M12x1.25x218.00mm (x10)

**JA5035** ■  
**JD468** ■  
MLS

**JM5028**  
(Elastomer)  
→Eng.4081110  
**JM5204**  
(Elastomer)  
Eng.4081111→

**HR363** ■

**NA5053**  
30.00x42.00x7.00mm FPM



AA5561

AA5571

AA5581

## 238



82.00

Diesel



937 A4.000

4 Cyl.

1910cc

93-103kW (126-140)PS

Turbocharged

TD18844

946



KIT



**TB725**  
198x24

**TBK350**  
Component No: TB725;  
AE1182GP;AE1041TP

**FOL187** (x16)

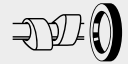
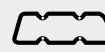

**AD5840** MLS, 0.820mm, 0 Holes  
**AD5850** MLS, 0.920mm, 1 Hole  
**AD5860** MLS, 1.020mm, 2 Holes

**CD5840** ▲

**HBS370** ☒  
M12x1.25x225.00mm (x10)

**JD5376** ■

**JM7055**  
(Steel Elastomer)

**HR5095** ■

**NA5053**  
30.00x42.00x7.00mm FPM



AD5840

AD5850

AD5860

<b>239</b>	<b>82.00</b>	<b>Diesel</b>				
<b>937 A4.000</b>	4 Cyl.	1910cc	<b>93kW (126)PS</b>	<b>Turbo Intercooled</b>	<b>TD18943</b>	<b>946</b>
<b>TB725</b> 198x24	<b>TBK350</b> Component No: TB725; AE1182GP;AE1041TP					<b>FOL187</b> (x16) Eng: 4654872→
<b>AD5840</b> MLS, 0.820mm, 0 Holes <b>AD5850</b> MLS, 0.920mm, 1 Hole <b>AD5860</b> MLS, 1.020mm, 2 Holes	<b>CD5840</b> ▲	<b>HBS370</b> ☒ M12x1.25x225.00mm (x10)	<b>JD5376</b> ■	<b>JM7055</b> (Steel Elastomer)	<b>HR5095</b> ☒	<b>NA5053</b> 30.00x42.00x7.00mm FPM
<b>AD5840</b>	<b>AD5850</b>	<b>AD5860</b>				

<b>240</b>	<b>82.00</b>	<b>Diesel</b>							
<b>937 A5.000</b>	4 Cyl.	17.5:1	1910cc	<b>110kW (150)PS</b>	<b>Turbo Intercooled</b>	<b>TD18929</b>	<b>946</b>		
<b>TB790</b> 199x24	<b>TBK306</b> Component No: TB790; AE1182GP;AE1041TP						<b>FOL187</b> (x16)		
<b>V94588</b> ■ 27.90 x 6.00 x 114.00 Eng.→5192515	<b>V98005</b> ■ 28.00 x 5.00 x 114.40 Eng.5192516→	<b>V94589</b> ☒ 25.80 x 6.00 x 114.30 Eng.→5192515	<b>V98006</b> ☒ 24.50 x 5.00 x 114.40 Eng.5192516→	<b>CD5840</b> ▲	<b>HBS370</b> ☒ M12x1.25x225.00mm (x10)	<b>JD5376</b> ■	<b>JM7055</b> (Steel Elastomer)	<b>HR5095</b> ☒	<b>NA5053</b> 30.00x42.00x7.00mm FPM
<b>AD5840</b>	<b>AD5850</b>	<b>AD5860</b>							

<b>V94588</b> ■ 27.90 x 6.00 x 114.00 Eng.→5192515	<b>V98005</b> ■ 28.00 x 5.00 x 114.40 Eng.5192516→	<b>V94589</b> ☒ 25.80 x 6.00 x 114.30 Eng.→5192515	<b>V98006</b> ☒ 24.50 x 5.00 x 114.40 Eng.5192516→	<b>CD5840</b> ▲	<b>HBS370</b> ☒ M12x1.25x225.00mm (x10)	<b>JD5376</b> ■	<b>JM7055</b> (Steel Elastomer)	<b>HR5095</b> ☒	<b>NA5053</b> 30.00x42.00x7.00mm FPM
<b>AD5840</b>	<b>AD5850</b>	<b>AD5860</b>							

# FIAT GROUP

**241**

**82.00**

**Diesel**



937 A5.000

4 Cyl.

1910cc

110kW (150)PS

Turbo Intercooled

TD18078

**946**

<b>TB725</b> 198x24 For OE no: 46791189	<b>TBK350</b> Component No: TB725; AE1182GP;AE1041TP				<b>FOL187</b> (x16)
<b>TB790</b> 199x24 For OE no: 55183528	<b>TBK306</b> Component No: TB790; AE1182GP;AE1041TP				

B x C x D	OE	Ex F x G
<b>V94588</b> ■ 27.90 x 6.00 x 114.00 →06/06	46 802 049	 45° Y H
<b>V98005</b> ■ 28.00 x 5.00 x 114.40 07/06→	55206431	 45°
<b>V94589</b> ■ 25.80 x 6.00 x 114.30 →06/06	46 787 902	 45° H
<b>V98006</b> ■ 24.50 x 5.00 x 114.40 07/06→	55205183	 45°

<b>AD5840</b> MLS, 0.820mm, 0 Holes <b>AD5850</b> MLS, 0.920mm, 1 Hole <b>AD5860</b> MLS, 1.020mm, 2 Holes	<b>CD5840</b> ▲	<b>HBS370</b> ☉ M12x1.25x225.00mm (x10)	<b>JD5376</b> ■	<b>JM7055</b> (Steel Elastomer)	<b>HR5095</b> ■	<b>NA5053</b> 30.00x42.00x7.00mm FPM
<b>AD5840</b>	<b>AD5850</b>	<b>AD5860</b>				

**242**

**82.00**

**Diesel**



937 A6.000

4 Cyl.

17.5:1

1910cc

125kW (170)PS

Turbo Intercooled

TD24643

**956**

					<b>FOL187</b> (x16)

<b>AD5840</b> MLS, 0.820mm, 0 Holes <b>AD5850</b> MLS, 0.920mm, 1 Hole <b>AD5860</b> MLS, 1.020mm, 2 Holes	<b>CD5840</b> ▲	<b>HBS370</b> ☉ M12x1.25x225.00mm (x10)	<b>JD5376</b> ■	<b>JM7055</b> (Steel Elastomer)	<b>HR5095</b> ■	<b>NA5053</b> 30.00x42.00x7.00mm FPM
<b>AD5840</b>	<b>AD5850</b>	<b>AD5860</b>				



<b>243</b>	<b>82.00</b>	<b>Diesel</b>				
<b>937 A7.000</b>	4 Cyl.	1910cc	<b>85kW (115)PS</b>	<b>Turbo Intercooled</b>	<b>TD20933</b>	<b>958</b>
<b>TB639</b> 190x24		<b>CAM654</b>			<b>FOL104 (x8) [6]</b>	

[6] Mechanical [6] Mécanique [6] Meccanico [6] Mecánico

<b>AG7440</b> MLS <b>AG7390</b> MLS, 0.820mm <b>AG7400</b> MLS, 0.920mm, 1 Hole	<b>CG7390</b> ▲	<b>FA5560</b> ▲	<b>HBS227</b> ☒ M12x1.25x218.00mm (x10)	<b>JA5035</b> ■ <b>JD468</b> ■ MLS	<b>JM5204</b> (Elastomer) Eng.4081111→	<b>HR363</b> ■	<b>NA5053</b> 30.00x42.00x7.00mm FPM
<b>AG7390</b>	<b>AG7400</b>	<b>AG7440</b>					

<b>244</b>	<b>82.00</b>	<b>Diesel</b>				
<b>937 A7.000</b>	4 Cyl.	1910cc	<b>85kW (115)PS</b>	<b>Turbo Intercooled</b>	<b>TD19307</b>	<b>957</b>
<b>TB639</b> 190x24		<b>TBK283</b> Component No: TB639; AE1041TP;AE1182GP			<b>FOL104 (x8) [6]</b>	

[6] Mechanical [6] Mécanique [6] Meccanico [6] Mecánico

<b>V94470</b> ■ 35.30 x 8.00 x 115.00	46 750 859	MG cr	45°	H	<b>VAG96124</b> ■ ■ 42.90 x 8.02 x 14.06	<b>VAG96203</b> ■ ■ 43.00 x 8.03 x 14.08	<b>VAG96210</b> ■ ■ 43.00 x 8.04 x 14.04
<b>V94471</b> ■ 34.50 x 8.00 x 115.00	46 783 962	MG cr	45°	H			

<b>AA5561</b> MLS, 0.820mm, 0 Holes →09/03 <b>AA5571</b> MLS, 0.920mm, 1 Hole →09/03 <b>AA5581</b> MLS, 1.020mm, 2 Holes →09/03 <b>AG7440</b> MLS 10/03→ <b>AG7390</b> MLS, 0.820mm 10/03→ <b>AG7400</b> MLS, 0.920mm, 1 Hole 10/03→	<b>CA5560</b> ▲ →Eng.4081110 <b>CA5561</b> ▲ Eng.4081111→ <b>CG7390</b> ▲ 10/03→	<b>FA5560</b> ▲	<b>HBS227</b> ☒ M12x1.25x218.00mm (x10)	<b>JA5035</b> ■ <b>JD468</b> ■ MLS	<b>JM5028</b> (Elastomer) →Eng.4081110 <b>JM5204</b> (Elastomer) Eng.4081111→	<b>HR363</b> ■	<b>NA5053</b> 30.00x42.00x7.00mm FPM
<b>AA5561</b>	<b>AA5571</b>	<b>AA5581</b>	<b>AG7390</b>	<b>AG7400</b>	<b>AG7440</b>		

# FIAT GROUP

<b>245</b>	<b>82.00</b>	<b>Diesel</b>					
<b>937 A8.000</b>	4 Cyl.	1910cc	<b>100-100kW (136-136)PS</b>	<b>Turbo Intercooled</b>	<b>TD20271</b>	<b>959</b>	
<b>TB790</b> 199x24	<b>TBK306</b> Component No: TB790; AE1182GP;AE1041TP				<b>FOL187 (x16)</b>		

<b>AD5840</b> MLS, 0.820mm, 0 Holes <b>AD5850</b> MLS, 0.920mm, 1 Hole <b>AD5860</b> MLS, 1.020mm, 2 Holes	<b>CD5840 ▲</b>		<b>HBS370 ☒</b> M12x1.25x225.00mm (x10)	<b>JD5376 ■</b>	<b>JM7055</b> (Steel Elastomer)	<b>HR5095 ☒</b>	<b>NA5053</b> 30.00x42.00x7.00mm FPM
<b>AD5840</b>	<b>AD5850</b>	<b>AD5860</b>					

<b>246</b>	<b>82.00</b>	<b>Diesel</b>					
<b>939 A1.000</b>	4 Cyl.	1910cc	<b>88kW (120)PS</b>	<b>Turbo Intercooled</b>	<b>TD18915</b>	<b>960</b>	
<b>TB639</b> 190x24	<b>CAM654</b>				<b>FOL104 (x8) [6]</b>		
[6] Mechanical	[6] Mécanique	[6] Meccanico	[6] Mecánico				

<b>V94470 ■</b> 35.30 x 8.00 x 115.00	<b>V94065 ☒</b> 34.50 x 8.00 x 115.00	<b>V94471 ☒</b> 34.50 x 8.00 x 115.00	<b>MG cr</b>	<b>MD cr</b>	<b>MG cr</b>	<b>H</b>	<b>H</b>

<b>AG7440</b> MLS <b>AG7390</b> MLS, 0.820mm <b>AG7400</b> MLS, 0.920mm, 1 Hole	<b>CG7390 ▲</b>		<b>HBS227 ☒</b> M12x1.25x218.00mm (x10)	<b>JD468 ☒</b> MLS	<b>JM5204</b> (Elastomer)	<b>HR363 ☒</b>	<b>NA5053</b> 30.00x42.00x7.00mm FPM
<b>AG7390</b>	<b>AG7400</b>	<b>AG7440</b>					

<b>247</b>	<b>82.00</b>	<b>Diesel</b>	
<b>939 A1.000</b>	4 Cyl.	1910cc	<b>88kW (120)PS</b>
			<b>Turbo Intercooled</b>
			<b>TD18448</b>
			<b>945</b>

<b>TB639</b> 190x24	<b>TBK283</b> Component No: TB639; AE1041TP;AE1182GP	<b>CAM654</b>	<b>FOL104 (x8) [6]</b>

[6] Mechanical      [6] Mécanique      [6] Meccanico      [6] Mecánico

	OE	MAT.		
B x C x D				E x F x G
<b>V94588</b> ■ 27.90 x 6.00 x 114.00 →06/06	46 802 049		45° Y H	
<b>V98005</b> ■ 28.00 x 5.00 x 114.40 07/06→	55206431		45°	
<b>V94589</b> ■ 25.80 x 6.00 x 114.30 →06/06	46 787 902		45° H	
<b>V98006</b> ■ 24.50 x 5.00 x 114.40 07/06→	55205183		45°	

<b>AG7440</b> MLS	<b>CG7390</b> ▲	<b>HBS227</b> Ⓢ M12x1.25x218.00mm (x10)	<b>JD468</b> ■ MLS	<b>JMS204</b> (Elastomer)	<b>HR363</b> ■	<b>NA5053</b> 30.00x42.00x7.00mm FPM
<b>AG7390</b> MLS, 0.820mm						
<b>AG7400</b> MLS, 0.920mm, 1 Hole						



**AG7390**



**AG7400**



**AG7440**

939 A2.000

4 Cyl.

17.5:1

1910cc

110kW (150)PS

Turbo Intercooled

TD18473

**961**

<b>TB790</b> 199x24	<b>TBK306</b> Component No: TB790; AE1182GP;AE1041TP				<b>FOL187</b> (x16)

	OE	MAT.				
B x C x D						E x F x G
<b>V94588</b> ■ 27.90 x 6.00 x 114.00 →06/06	46 802 049	 MB cr	45°	Y	H	
<b>V98005</b> ■ 28.00 x 5.00 x 114.40 07/06→	55206431	 MB cr	45°			
<b>V94589</b> ■ 25.80 x 6.00 x 114.30 →06/06	46 787 902	 MG cr	45°		H	
<b>V98006</b> ■ 24.50 x 5.00 x 114.40 07/06→	55205183	 MG cr	45°			

<b>AD5840</b> MLS, 0.820mm, 0 Holes	<b>AD5850</b> MLS, 0.920mm, 1 Hole	<b>AD5860</b> MLS, 1.020mm, 2 Holes	<b>HBS370</b> ☒ M12x1.25x225.00mm (x10) →07/07 <b>HBS465</b> ☒ M12x1.25x220.00mm (x10) 07/07→	<b>JD5376</b> ■ <b>JD273</b> ■ MLS	<b>JM7055</b> (Steel Elastomer)	<b>HR5095</b> ■	<b>NA5053</b> 30.00x42.00x7.00mm FPM

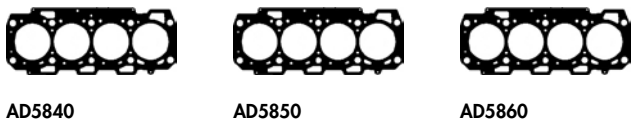

<b>249</b>	<b>82.00</b>	<b>Diesel</b>					
<b>939 A2.000</b>	4 Cyl.	17.5:1	1910cc	<b>110kW (150)PS</b>	<b>Turbo Intercooled</b>	<b>TD18449</b>	<b>961</b>
<b>TB790</b> 199x24	<b>TBK306</b> Component No: TB790; AE1182GP;AE1041TP						<b>FOL187</b> (x16) Eng: 4654872→

B x C x D	OE	MAT.				E x F x G
<b>V94588</b> ■ 27.90 x 6.00 x 114.00 →06/06	46 802 049	 MB cr	45°	Y	H	
<b>V98005</b> ■ 28.00 x 5.00 x 114.40 07/06→	55206431	 MB cr	45°			
<b>V94589</b> ■ 25.80 x 6.00 x 114.30 →06/06	46 787 902	 MG cr	45°		H	
<b>V98006</b> ■ 24.50 x 5.00 x 114.40 07/06→	55205183	 MG cr	45°			

<b>AD5840</b> MLS, 0.820mm, 0 Holes			<b>HBS370</b> ☒ M12x1.25x225.00mm (x10) →07/07	<b>JD5376</b> ■ <b>JD273</b> ■ MLS	<b>JM7055</b> (Steel Elastomer)	<b>HR5095</b> ■	<b>NA5053</b> 30.00x42.00x7.00mm FPM
<b>AD5850</b> MLS, 0.920mm, 1 Hole			<b>HBS465</b> ☒ M12x1.25x220.00mm (x10) 07/07→				
<b>AD5860</b> MLS, 1.020mm, 2 Holes							
<b>AD5840</b>	<b>AD5850</b>	<b>AD5860</b>					

<b>250</b>	<b>82.00</b>	<b>Diesel</b>				
<b>939 A7.000</b>	4 Cyl.	1910cc	<b>85kW (115)PS</b>	<b>Turbo Intercooled</b>	<b>TD18916</b>	<b>960</b>
<b>TB639</b> 190x24 06/05→	<b>TBK283</b> 06/05→ Component No: TB639; AE1041TP;AE1182GP	<b>CAM654</b>				<b>FOL104</b> (x8) [6]
[6] Mechanical	[6] Mécanique	[6] Meccanico	[6] Mecánico			

<b>AG7440</b> MLS	<b>CG7390</b> ▲		<b>HBS227</b> ☒ M12x1.25x218.00mm (x10)	<b>JD468</b> ■ MLS	<b>JM5204</b> (Elastomer)	<b>HR363</b> ■	<b>NA5053</b> 30.00x42.00x7.00mm FPM
<b>AG7390</b> MLS, 0.820mm							
<b>AG7400</b> MLS, 0.920mm, 1 Hole							
<b>AG7390</b>	<b>AG7400</b>	<b>AG7440</b>					

# FIAT GROUP

**251**



**82.00**

**Diesel**



939 A8.000

4 Cyl.

18.4:1

1910cc

100kW (136)PS

Turbo Intercooled

TD18925

**963**

<b>TB790</b> 199x24	<b>TBK306</b> Component No: TB790; AE1182GP;AE1041TP				<b>FOL187</b> (x16)



<b>AD5840</b> MLS, 0.820mm, 0 Holes <b>AD5850</b> MLS, 0.920mm, 1 Hole <b>AD5860</b> MLS, 1.020mm, 2 Holes	<b>CG7410</b> 06/04→	<b>HBS370</b> ☒ M12x1.25x225.00mm (x10) →07/07 <b>HBS465</b> ☒ M12x1.25x220.00mm (x10) 07/07→	<b>JD5376</b> ■ <b>JD273</b> ■ MLS	<b>JM7055</b> (Steel Elastomer)	<b>HR5095</b> ■	<b>NA5053</b> 30.00x42.00x7.00mm FPM
--	-------------------------	--	--	------------------------------------	-----------------	---



**AD5840**                      **AD5850**                      **AD5860**

**252**



**82.00**

**Diesel**



939 A8.000

4 Cyl.

18.4:1

1910cc

100kW (136)PS

Turbo Intercooled

TD25733

**962**

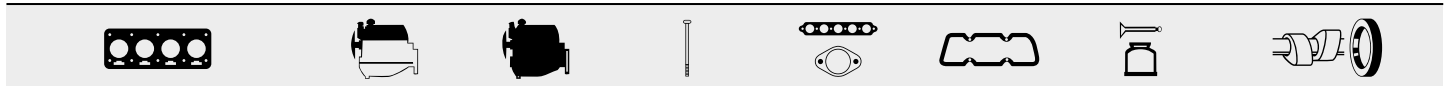

<b>AD5840</b> MLS, 0.820mm, 0 Holes <b>AD5850</b> MLS, 0.920mm, 1 Hole <b>AD5860</b> MLS, 1.020mm, 2 Holes	<b>CG7410</b> 06/04→	<b>HBS370</b> ☒ M12x1.25x225.00mm (x10) →07/07 <b>HBS465</b> ☒ M12x1.25x220.00mm (x10) 07/07→	<b>JD5376</b> ■ <b>JD273</b> ■ MLS	<b>JM7055</b> (Steel Elastomer)	<b>HR5095</b> ■	<b>NA5053</b> 30.00x42.00x7.00mm FPM
--	-------------------------	--	--	------------------------------------	-----------------	---



**AD5840**                      **AD5850**                      **AD5860**

<b>253</b>	<b>82.00</b>	<b>Diesel</b>					
<b>AR 32302</b>	4 Cyl.	18.5:1	1910cc	<b>77kW (105)PS</b>	<b>Turbocharged</b>	<b>TD9769</b>	<b>937</b>

<b>TB639</b> 190x24	<b>TBK104</b> Component No: TB639; AE1041TP;AE1087GP	<b>CAM651</b>	<b>KIT</b>	<b>FOL104 (x8) [6]</b>

[6] Mechanical      [6] Mécanique      [6] Meccanico      [6] Mecánico

	OE	MAT.		
B x C x D				E x F x G
<b>V94064</b> ■	608 14 605		45°	<b>VAG96203</b> ■ ■
35.50 x 8.00 x 115.00 →12/00		MB cr		43.00 x 8.03 x 14.08
<b>V94470</b> ■	46 750 859		45°	<b>VAG96210</b> ■ ■
35.30 x 8.00 x 115.00 01/01→		MG cr		43.00 x 8.04 x 14.04
<b>V94065</b> ■	608 14 604		45°	
34.50 x 8.00 x 115.00		MD cr		
<b>V94471</b> ■	46 783 962		45°	
34.50 x 8.00 x 115.00		MG cr		

<b>AY520</b> MLS, 1.600mm, 0 Holes <b>AY530</b> MLS, 1.700mm, 1 Hole <b>AY540</b> MLS, 1.800mm, 2 Holes	<b>CY550</b> ▲	<b>FY550</b> ▲	<b>HBS227</b> ⊗ M12x1.25x218.00mm (x10)	<b>JA5035</b> ■ <b>JD468</b> ■ MLS	<b>JP063</b>	<b>HR363</b> ■	<b>NA5053</b> 30.00x42.00x7.00mm FPM

**AY520, AY530, AY540**







## 254

 82.00









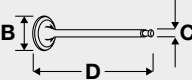

**Diesel**



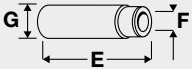







AR 32302      4 Cyl.      18.5:1      1910cc      77kW (105)PS      Turbocharged      TD17398      937

					
<b>TB639</b> 190x24	<b>TBK283</b> Eng.→4130907 Component No: TB639; AE1041TP;AE1182GP	<b>CAM651</b>	<b>KIT</b>		<b>FOL104 (x8) [6]</b>

[6] Mechanical      [6] Mécanique      [6] Meccanico      [6] Mecánico

 B x C x D	OE	MAT.				 E x F x G
<b>V94064</b> ■	608 14 605	 MB cr	45°	H		<b>VAG96124</b> ■ ■ ■ 42.90 x 8.02 x 14.06
<b>V94470</b> ■	46 750 859	 MG cr	45°	H		<b>VAG96203</b> ■ ■ ■ 43.00 x 8.03 x 14.08
<b>V94065</b> ■	608 14 604	 MD cr	45°			<b>VAG96210</b> ■ ■ ■ 43.00 x 8.04 x 14.04
<b>V94471</b> ■	46 783 962	 MG cr	45°	H		
<b>V94590</b> ■		 MG cr	45°	ss	H	

							
<b>AY520</b> MLS, 1.600mm, 0 Holes	<b>CY550</b> ▲	<b>FY550</b> ▲	<b>HBS227</b> ☒ M12x1.25x218.00mm (x10)	<b>JA5035</b> ■ <b>JD468</b> ■ MLS	<b>JP063</b>	<b>HR363</b> ■	<b>NA5053</b> 30.00x42.00x7.00mm FPM

  
**AY520, AY530, AY540**



## 255

## 82.00

## Diesel



AR 37101

4 Cyl.

18.5:1

1910cc

80-85kW (109-116)PS

Turbo Intercooled

TD17890

964

<b>TB639</b> 190x24	<b>TBK283</b> Eng. → 4130907 Component No: TB639; AE1041TP; AE1182GP	<b>CAM654</b>	<b>FOL104 (x8) [6]</b>

[6] Mechanical

[6] Mécanique

[6] Meccanico

[6] Mecánico

 B x C x D	OE	MAT.					 E x F x G
<b>V94064</b> ■	608 14 605		45°		H		<b>VAG96124</b> ■ ■ ■
35.50 x 8.00 x 115.00		MB cr					42.90 x 8.02 x 14.06
<b>V94470</b> ■	46 750 859		45°		H		<b>VAG96203</b> ■ ■ ■
35.30 x 8.00 x 115.00		MG cr					43.00 x 8.03 x 14.08
<b>V94065</b> ■	608 14 604		45°				<b>VAG96210</b> ■ ■ ■
34.50 x 8.00 x 115.00		MD cr					43.00 x 8.04 x 14.04
<b>V94471</b> ■	46 783 962		45°		H		
34.50 x 8.00 x 115.00		MG cr					
<b>V94590</b> ■			45°	ss	H		
34.45 x 8.00 x 115.00		MG cr					

<b>AA5561</b> MLS, 0.820mm, 0 Holes <b>AA5571</b> MLS, 0.920mm, 1 Hole <b>AA5581</b> MLS, 1.020mm, 2 Holes	<b>CA5560</b> ▲ → Eng. 4081110 <b>CA5561</b> ▲ Eng. 4081111 →	<b>FA5560</b> ▲	<b>HBS227</b> Ⓢ M12x1.25x218.00mm (x10)	<b>JA5035</b> ■ <b>JD468</b> ■ MLS	<b>JM5028</b> (Elastomer) → Eng. 4081110 <b>JM5204</b> (Elastomer) Eng. 4081111 →	<b>HR363</b> ■	<b>NA5053</b> 30.00x42.00x7.00mm FPM



AA5561



AA5571



AA5581



AR 37101      4 Cyl.      18.5:1      1910cc      81kW (110)PS      TD15510      954

<b>TB639</b> 190x24	<b>TBK283</b> Component No: TB639; AE1041TP;AE1182GP	<b>CAM654</b>		<b>FOL104 (x8) [6]</b>

[6] Mechanical      [6] Mécanique      [6] Meccanico      [6] Mecánico

B x C x D	OE	E x F x G
<b>V94470</b> ■	46 750 859	<b>VAG96203</b> ■ ■ ■
35.30 x 8.00 x 115.00		43.00 x 8.03 x 14.08
<b>V94471</b> ■	46 783 962	<b>VAG96210</b> ■ ■ ■
34.50 x 8.00 x 115.00		43.00 x 8.04 x 14.04
<b>V94590</b> ■		
34.45 x 8.00 x 115.00		

<b>AA5561</b> MLS, 0.820mm, 0 Holes <b>AA5571</b> MLS, 0.920mm, 1 Hole <b>AA5581</b> MLS, 1.020mm, 2 Holes	<b>CA5560</b> ▲ →Eng.4081110 <b>CA5561</b> ▲ Eng.4081111→	<b>FA5560</b> ▲	<b>HBS227</b> ☒ M12x1.25x218.00mm (x10)	<b>JA5035</b> ■ <b>JD468</b> ■ MLS	<b>JM5028</b> (Elastomer) →Eng.4081110 <b>JM5204</b> (Elastomer) Eng.4081111→	<b>HR363</b> ■	<b>NA5053</b> 30.00x42.00x7.00mm FPM



AA5561



AA5571



AA5581







## 257







 82.00



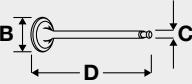



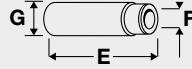



**Diesel**

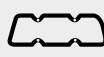

D19AA      4 Cyl.      18:1      1910cc      88kW (120)PS      Turbo Intercooled      TD20930      950

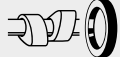
					
<b>TB639</b> 190x24		<b>CAM654</b>			<b>FOL104 (x8) [6]</b>
[6] Mechanical	[6] Mécanique	[6] Meccanico	[6] Mecánico		

					
B x C x D	OE	MAT.	45°	H	E x F x G
<b>V94470</b> ■	46 750 859		45°	H	<b>VAG96124</b> ■ ■
35.30 x 8.00 x 115.00		MG cr			42.90 x 8.02 x 14.06
<b>V94471</b> ■	46 783 962		45°	H	<b>VAG96203</b> ■ ■
34.50 x 8.00 x 115.00		MG cr			43.00 x 8.03 x 14.08
					<b>VAG96210</b> ■ ■
					43.00 x 8.04 x 14.04

							
<b>AG7440</b> MLS	<b>CG7390</b> ▲	<b>HBS227</b> Ⓢ	<b>JD468</b> ■	<b>JM5204</b>	<b>HR363</b> ■	<b>NA5053</b>	
<b>AG7390</b> MLS, 0.820mm		M12x1.25x218.00mm (x10)	MLS	(Elastomer)		30.00x42.00x7.00mm FPM	
<b>AG7400</b> MLS, 0.920mm, 1 Hole							
							
<b>AG7390</b>	<b>AG7400</b>	<b>AG7440</b>					

**258**

 **82.00**

**Petrol**



175 A3.000

5 Cyl.

8.5:1







1998cc





162kW (220)PS





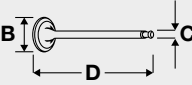

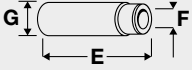
Turbocharged

TD11550

**965**



					
<b>TB462</b> 167x24 →05/01					<b>FOL106 (x20)</b> Height: 24mm

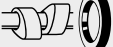





 B x C x D	OE	MAT.	 	 E x F x G
<b>V91931</b> ■ 30.00 x 7.00 x 113.00	608 12 982	 MB cr	45° H	<b>VAG96123</b> ■ 42.25 x 7.02 x 13.05
<b>V91932</b> ■ 26.00 x 7.00 x 108.50	608 12 981	 MG cr	45° H	<b>VAG96146</b> ■ 42.50 x 7.04 x 13.05
				<b>VAG96229</b> ■ 42.50 x 7.04 x 13.08
				<b>VAG96145</b> ■ 46.00 x 7.02 x 13.03
				<b>VAG96230</b> ■ 46.00 x 7.02 x 13.06











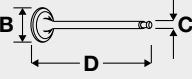

							
<b>AY320</b> MLS, 1.800mm	<b>CY320</b>	<b>FY320</b>	<b>HBS133</b> ☉ M10x1.25x254.00mm (x12)	<b>JD225</b> ■ <b>JD226</b> ■	<b>JN933</b>	<b>HR800</b> ■	<b>NA5053</b> 30.00x42.00x7.00mm FPM <b>NA5069</b> 55.00x68.00x8.00mm FPM

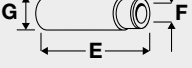

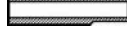

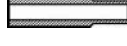





AY320

<b>259</b>	 <b>82.00</b>	<b>Petrol</b>					
<b>175 A3.000</b>	5 Cyl.	8.5:1	1998cc	<b>162kW (220)PS</b>	<b>Turbo Intercooled</b>	<b>TD5491</b>	<b>965</b>

					
<b>TB462</b> 167x24					<b>FOL106</b> (x16) Height: 24mm <b>FOL145</b> (x20) Height: 26mm

	OE	MAT.				
B x C x D						E x F x G
<b>V91931</b> ■ 30.00 x 7.00 x 113.00	608 12 982	 MB cr	45°	H		 <b>VAG96123</b> ■ 42.25 x 7.02 x 13.05
<b>V91932</b> ■ 26.00 x 7.00 x 108.50	608 12 981	 MG cr	45°	H		 <b>VAG96146</b> ■ 42.50 x 7.04 x 13.05
						 <b>VAG96229</b> ■ 42.50 x 7.04 x 13.08
						 <b>VAG96145</b> ■ 46.00 x 7.02 x 13.03
						 <b>VAG96230</b> ■ 46.00 x 7.02 x 13.06

							
<b>AY320</b> MLS, 1.800mm	<b>CY320</b>	<b>FY320</b>	<b>HBS133</b> ⊗ M10x1.25x254.00mm (x12)	<b>JD225</b> ■ <b>JD226</b> ■	<b>JN933</b>	<b>HR800</b> ■	<b>NA5053</b> 30.00x42.00x7.00mm FPM <b>NA5069</b> 55.00x68.00x8.00mm FPM



**AY320**

## 260

 82.00

Petrol



182 A1.000

5 Cyl.







10:1





1998cc





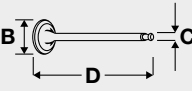

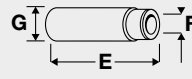

108kW (147)PS

TD4397

966

					
<b>TB462</b> 167x24 11/96 →					
				<b>FOL106</b> (x20) Height: 24mm <b>FOL126</b> (x20) [6]	
[6] Mechanical	[6] Mécanique	[6] Meccanico	[6] Mecánico		







	OE	MAT.			
B x C x D					E x F x G
<b>V91931</b> ■ 30.00 x 7.00 x 113.00	608 12 982	 MB cr	45°	H	<b>VAG96123</b> ■ 42.25 x 7.02 x 13.05
<b>V91932</b> ■ 26.00 x 7.00 x 108.50	608 12 981	 MG cr	45°	H	<b>VAG96146</b> ■ 42.50 x 7.04 x 13.05
					<b>VAG96229</b> ■ 42.50 x 7.04 x 13.08
					<b>VAG96145</b> ■ 46.00 x 7.02 x 13.03
					<b>VAG96230</b> ■ 46.00 x 7.02 x 13.06











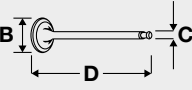

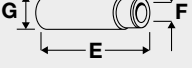
							
<b>BW321</b> Fibre Composite	<b>DW320</b>	<b>GW321</b>	<b>HBS133</b> ☒ M10x1.25x254.00mm (x12)	<b>JD225</b> ■ <b>JD226</b> ■	<b>JN933</b>	<b>HR800</b> ■	<b>NA5053</b> 30.00x42.00x7.00mm FPM <b>NA5069</b> 55.00x68.00x8.00mm FPM













BW321

<b>261</b>	 <b>82.00</b>	<b>Petrol</b>	
<b>182 B3.000</b>	5 Cyl.	10:1	1998cc
			<b>113kW (154)PS</b>
			<b>TD11789 967</b>

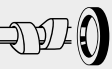
					
			<b>KIT</b>		<b>FOL106 (x20)</b> Height: 24mm

 B x C x D	OE	MAT.			 E x F x G
<b>V91933</b>  33.40 x 7.00 x 113.10	608 11 153	 MB cr	45°	H	<b>VAG96123</b>  42.25 x 7.02 x 13.05
<b>V91934</b>  28.00 x 7.00 x 108.60	608 11 154	 MD cr	45°	ss	<b>VAG96146</b>  42.50 x 7.04 x 13.05
					<b>VAG96229</b>  42.50 x 7.04 x 13.08
					<b>VAG96145</b>  46.00 x 7.02 x 13.03
					<b>VAG96230</b>  46.00 x 7.02 x 13.06

							
<b>BW321</b> Fibre Composite	<b>DW322</b>		<b>HBS133</b>  M10x1.25x254.00mm (x12)	<b>JD225</b>  <b>JD226</b> 	<b>JM5018</b> (Elastomer)	<b>HR800</b> 	<b>NA5053</b> 30.00x42.00x7.00mm FPM <b>NA5069</b> 55.00x68.00x8.00mm FPM



BW321

**262**

 **82.00**

**Petrol**



182 B7.000

5 Cyl.







10.7:1





1998cc





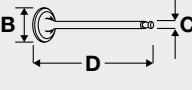

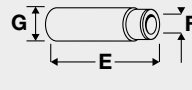
113kW (154)PS

TD15498

**968**

					
<b>TB462</b> 167x24 →08/00					<b>FOL106</b> (x20) Height: 24mm <b>FOL145</b> (x20) Height: 26mm

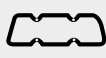
 B x C x D	OE	MAT.	 45°	 H	 E x F x G
<b>V91933</b> ■ 33.40 x 7.00 x 113.10	608 11 153	 MB cr	45°	H	<b>VAG96123</b> ■ 42.25 x 7.02 x 13.05
<b>V91934</b> ■ 28.00 x 7.00 x 108.60	608 11 154	 MD cr	45°	ss	<b>VAG96146</b> ■ 42.50 x 7.04 x 13.05
					<b>VAG96229</b> ■ 42.50 x 7.04 x 13.08
					<b>VAG96145</b> ■ 46.00 x 7.02 x 13.03
					<b>VAG96230</b> ■ 46.00 x 7.02 x 13.06

						
<b>BW321</b> Fibre Composite	<b>DW322</b>	<b>HBS133</b> ☒ M10x1.25x254.00mm (x12)	<b>JD225</b> ■ <b>JD226</b> ■	<b>JM5018</b> (Elastomer)	<b>HR800</b> ■	<b>NA5053</b> 30.00x42.00x7.00mm FPM <b>NA5069</b> 55.00x68.00x8.00mm FPM



**BW321**



<b>263</b>	<b>82.00</b>	<b>Petrol</b>							
<b>182 B7.000</b>	5 Cyl.	10.7:1	1998cc	<b>113kW (154)PS</b>				<b>TD14389</b>	<b>966</b>

<b>TB462</b>					
167x24					

	OE	MAT.			
B x C x D					E x F x G
<b>V91933</b>	608 11 153		45°	H	<b>VAG96123</b>
33.40 x 7.00 x 113.10		MB cr			42.25 x 7.02 x 13.05
<b>V91934</b>	608 11 154		45°	ss	<b>VAG96146</b>
28.00 x 7.00 x 108.60		MD cr			42.50 x 7.04 x 13.05
					<b>VAG96229</b>
					42.50 x 7.04 x 13.08
					<b>VAG96145</b>
					46.00 x 7.02 x 13.03
					<b>VAG96230</b>
					46.00 x 7.02 x 13.06

<b>BW321</b> Fibre Composite	<b>DW322</b>		<b>HBS133</b> M10x1.25x254.00mm (x12)	<b>JD225</b> <b>JD226</b>	<b>JM5018</b> (Elastomer)	<b>HR800</b>	<b>NA5053</b> 30.00x42.00x7.00mm FPM <b>NA5069</b> 55.00x68.00x8.00mm FPM



BW321

<b>264</b>	<b>82.00</b>	<b>Petrol</b>							
<b>185 A8.000</b>	5 Cyl.	10.5:1	1998cc	<b>110kW (150)PS</b>				<b>TD15630</b>	<b>970</b>

	OE	MAT.			
B x C x D					E x F x G
<b>V91933</b>	608 11 153		45°	H	<b>VAG96123</b>
33.40 x 7.00 x 113.10		MB cr			42.25 x 7.02 x 13.05
<b>V91934</b>	608 11 154		45°	ss	<b>VAG96146</b>
28.00 x 7.00 x 108.60		MD cr			42.50 x 7.04 x 13.05
					<b>VAG96229</b>
					42.50 x 7.04 x 13.08
					<b>VAG96145</b>
					46.00 x 7.02 x 13.03
					<b>VAG96230</b>
					46.00 x 7.02 x 13.06

<b>AA5590</b> MLS, 0.490mm	<b>CA5590</b>		<b>HBS133</b> M10x1.25x254.00mm (x12)	<b>JD225</b> <b>JD226</b>	<b>JM5018</b> (Elastomer)	<b>HR800</b>	<b>NA5053</b> 30.00x42.00x7.00mm FPM <b>NA5069</b> 55.00x68.00x8.00mm FPM



AA5590

## 265

 82.00

Petrol



185 A8.000 Euro 3 (D3)

5 Cyl.







10.5:1





1998cc





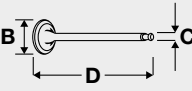

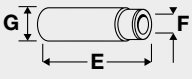

110kW (150)PS

TD15830

970

					
			<b>KIT</b>		<b>FOL106</b> (x20) Height: 24mm <b>FOL145</b> (x20) Height: 26mm

 B x C x D	OE	MAT.			 E x F x G
<b>V91933</b> ■ 33.40 x 7.00 x 113.10	608 11 153	 MB cr	45°	H	<b>VAG96123</b> ■ 42.25 x 7.02 x 13.05
<b>V91934</b> ■ 28.00 x 7.00 x 108.60	608 11 154	 MD cr	45°	ss	<b>VAG96146</b> ■ 42.50 x 7.04 x 13.05
					<b>VAG96229</b> ■ 42.50 x 7.04 x 13.08
					<b>VAG96145</b> ■ 46.00 x 7.02 x 13.03
					<b>VAG96230</b> ■ 46.00 x 7.02 x 13.06

							
<b>AA5590</b> MLS, 0.490mm	<b>CA5590</b>		<b>HBS133</b> ☒ M10x1.25x254.00mm (x12)	<b>JD225</b> ■ <b>JD226</b> ■	<b>JM5018</b> (Elastomer)	<b>HR800</b> ■	<b>NA5053</b> 30.00x42.00x7.00mm FPM <b>NA5069</b> 55.00x68.00x8.00mm FPM



AA5590

## 266

 82.00

Petrol



838 A1.000

5 Cyl.







10:1





1998cc





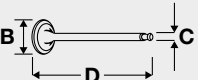

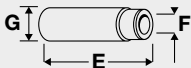
107kW (146)PS

TD4616

966

					
<b>TB462</b> 167x24					<b>FOL106</b> (x20) Height: 24mm <b>FOL145</b> (x20) Height: 26mm

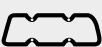
	OE	MAT.			
B x C x D					E x F x G
<b>V91931</b> ■ 30.00 x 7.00 x 113.00	608 12 982	 MB cr	45°	H	<b>VAG96123</b> ■ 42.25 x 7.02 x 13.05
<b>V91932</b> ■ 26.00 x 7.00 x 108.50	608 12 981	 MG cr	45°	H	<b>VAG96146</b> ■ 42.50 x 7.04 x 13.05
					<b>VAG96229</b> ■ 42.50 x 7.04 x 13.08
					<b>VAG96145</b> ■ 46.00 x 7.02 x 13.03
					<b>VAG96230</b> ■ 46.00 x 7.02 x 13.06

							
<b>BW321</b> Fibre Composite	<b>DW320</b>	<b>HBS133</b> ⊗ M10x1.25x254.00mm (x12)	<b>JD225</b> ■ <b>JD226</b> ■	<b>JN933</b>	<b>HR800</b> ■	<b>NA5053</b> 30.00x42.00x7.00mm FPM	<b>NA5069</b> 55.00x68.00x8.00mm FPM



BW321

**267**

 **82.00**

**Petrol**



838 A6.000

5 Cyl.







10.4:1





1998cc





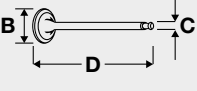

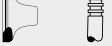
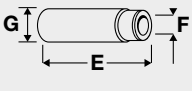
114kW (155)PS

TD5436

968

					
<b>TB462</b> 167x24					
				<b>FOL106</b> (x20) Height: 24mm <b>FOL145</b> (x20) Height: 26mm	

 B x C x D	OE	MAT.			 E x F x G
<b>V91933</b> ■ 33.40 x 7.00 x 113.10	608 11 153	 MB cr	45°	H	<b>VAG96123</b> ■ 42.25 x 7.02 x 13.05
<b>V91934</b> ■ 28.00 x 7.00 x 108.60	608 11 154	 MD cr	45°	ss	<b>VAG96146</b> ■ 42.50 x 7.04 x 13.05
					<b>VAG96229</b> ■ 42.50 x 7.04 x 13.08
					<b>VAG96145</b> ■ 46.00 x 7.02 x 13.03
					<b>VAG96230</b> ■ 46.00 x 7.02 x 13.06

						
<b>BW321</b> Fibre Composite	<b>DW322</b>	<b>HBS133</b> ☒ M10x1.25x254.00mm (x12)	<b>JD225</b> ■ <b>JD226</b> ■	<b>JM5018</b> (Elastomer)	<b>HR800</b> ■	<b>NA5053</b> 30.00x42.00x7.00mm FPM <b>NA5069</b> 55.00x68.00x8.00mm FPM



BW321

<b>268</b>	<b>82.00</b>	<b>Petrol</b>					
<b>841 E.000</b>	5 Cyl.	8.5:1	1998cc	<b>136kW (185)PS</b>	<b>Turbo Intercooled</b>	<b>TD16731</b>	<b>971</b>

	<b>.KIT</b>		<b>KIT</b>		
					<b>FOL106</b> (x20) Height: 24mm <b>FOL145</b> (x20) Height: 26mm

B x C x D	OE	MAT.	45°		E x F x G
<b>V91933</b> ■ 33.40 x 7.00 x 113.10	608 11 153	MB cr	45°	H	<b>VAG96123</b> ■ 42.25 x 7.02 x 13.05
<b>V91934</b> ■ 28.00 x 7.00 x 108.60	608 11 154	MD cr	45°	ss	<b>VAG96146</b> ■ 42.50 x 7.04 x 13.05
					<b>VAG96229</b> ■ 42.50 x 7.04 x 13.08
					<b>VAG96145</b> ■ 46.00 x 7.02 x 13.03
					<b>VAG96230</b> ■ 46.00 x 7.02 x 13.06

<b>AD5960</b> MLS	<b>CD5960</b>		<b>HBS133</b> Ⓢ M10x1.25x254.00mm (x12)				<b>NA5053</b> 30.00x42.00x7.00mm FPM



AD5960

**269**

 **82.00**

**Diesel**



185 A2.000

5 Cyl.

20.7:1







2387cc







91kW (125)PS



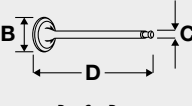



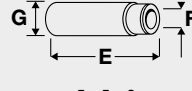

Turbo Intercooled

TD4406

972

					
<b>TB608</b> 193x24	<b>TBK352</b> Component No: TB608; AE1087GP;AE1041TP				

					
B x C x D	OE	MAT.			E x F x G
<b>V91937</b> ■ 37.50 x 8.00 x 114.20	7 798 620	 MD cr	45°		<b>VAG96124</b> ■ ■ ■ 42.90 x 8.02 x 14.06
<b>V91938</b> ■ 31.00 x 8.00 x 114.00	7 783 225	 MD cr	45°		<b>VAG96203</b> ■ ■ ■ 43.00 x 8.03 x 14.08
					<b>VAG96210</b> ■ ■ ■ 43.00 x 8.04 x 14.04

							
<b>AA5720</b> MLS, 1.600mm <b>BW340</b> Fibre Composite, 1.600mm <b>AA5730</b> MLS, 1.700mm, 1 Notch <b>BW350</b> Fibre Composite, 1.700mm, 1 Notch <b>AA5740</b> MLS, 1.800mm, 2 Notches <b>BW360</b> Fibre Composite, 1.800mm, 2 Notches	<b>DW340</b> ▲	<b>GW341</b> ▲	<b>HBS257</b> ⊗ M12x1.25x218.00mm (x12)	<b>JD227</b> ■ <b>JD228</b> ■	<b>JN934</b>	<b>HR363</b> ■	<b>NA5053</b> 30.00x42.00x7.00mm FPM



AA5720, AA5730, AA5740



BW340, BW350, BW360

<b>270</b>	<b>82.00</b>	<b>Diesel</b>							
<b>185 A6.000</b>	5 Cyl.	18.45:1	2387cc	<b>96kW (130)PS</b>	<b>Turbo Intercooled</b>	<b>TD18145</b>	<b>973</b>		

<b>TB639</b> 190x24	<b>TBK104</b> Component No: TB639; AE1041TP;AE1087GP	<b>CAM652</b> →12/02	<b>KIT</b>	<b>FOL104</b> (x10) [6]

[6] Mechanical      [6] Mécanique      [6] Meccanico      [6] Mecánico

	OE	MAT.			
B x C x D					E x F x G
<b>V94064</b>	608 14 605		45°	H	<b>VAG96124</b>
35.50 x 8.00 x 115.00		MB cr			42.90 x 8.02 x 14.06
<b>V94470</b>	46 750 859		45°	H	<b>VAG96203</b>
35.30 x 8.00 x 115.00		MG cr			43.00 x 8.03 x 14.08
<b>V94065</b>	608 14 604		45°		<b>VAG96210</b>
34.50 x 8.00 x 115.00		MD cr			43.00 x 8.04 x 14.04
<b>V94471</b>	46 783 962		45°	H	
34.50 x 8.00 x 115.00		MG cr			
<b>V94590</b>			45°	ss H	
34.45 x 8.00 x 115.00		MG cr			

<b>AY550</b> MLS, 1.600mm	<b>CY520</b> ▲	<b>FY520</b> ▲	<b>HBS257</b>	<b>JA5036</b>	<b>JP064</b>	<b>HR363</b>	<b>NA5053</b>
<b>AY560</b> MLS, 1.700mm, 1 Hole			M12x1.25x218.00mm (x12)	<b>JD228</b>			30.00x42.00x7.00mm FPM
<b>AY570</b> MLS, 1.800mm, 2 Holes							



AY550, AY560, AY570



<b>838 A3.000</b>	5 Cyl.	21:1	2387cc	<b>91kW (124)PS</b>	<b>Turbo Intercooled</b>	<b>TD4618</b>	<b>974</b>
<b>838 A7.000</b>	5 Cyl.	21:1	2387cc	<b>91kW (124)PS</b>	<b>Turbo Intercooled</b>	<b>TD5437</b>	<b>974</b>

<b>TB608</b> 193x24	<b>TBK352</b> Component No: TB608; AE1087GP;AE1041TP	<b>CAM652</b>		<b>FOL104 (x10) [6]</b>

[6] Mechanical      [6] Mécanique      [6] Meccanico      [6] Mecánico

<b>V91937</b> ■ 37.50 x 8.00 x 114.20	<b>V91938</b> ■ 31.00 x 8.00 x 114.00	<b>VAG96124</b> ■ ■ ■ 42.90 x 8.02 x 14.06	<b>VAG96203</b> ■ ■ ■ 43.00 x 8.03 x 14.08	<b>VAG96210</b> ■ ■ ■ 43.00 x 8.04 x 14.04

<b>BW340</b> Fibre Composite, 1.600mm →Eng.0345336	<b>BW350</b> Fibre Composite, 1.700mm, 1 Notch →Eng.0345336	<b>BW360</b> Fibre Composite, 1.800mm, 2 Notches →Eng.0345336	<b>AA5720</b> MLS, 1.600mm Eng.0345337 →	<b>AA5730</b> MLS, 1.700mm, 1 Notch Eng.0345337 →	<b>AA5740</b> MLS, 1.800mm, 2 Notches Eng.0345337 →	<b>DW340</b> ▲	<b>GW341</b> ▲	<b>HBS257</b> ⊗ M12x1.25x218.00mm (x12)	<b>JD227</b> ■ <b>JD228</b> ■	<b>JN934</b>	<b>HR363</b> ■	<b>NA5053</b> 30.00x42.00x7.00mm FPM



AA5720, AA5730, AA5740



BW340, BW350, BW360



## 272

## 82.00

## Diesel



838 A8.000

5 Cyl.

18.45:1

2387cc

100kW (136)PS

Turbocharged

TD11551

975

<b>TB639</b> 190x24 →05/01	<b>TBK104</b> Component No: TB639; AE1041TP;AE1087GP	<b>CAM652</b>		<b>FOL104</b> (x10) [6]
[6] Mechanical	[6] Mécanique	[6] Meccanico	[6] Mecánico	

	OE	MAT.			
B x C x D					E x F x G
<b>V94064</b> ■	608 14 605		45°	H	<b>VAG96124</b> ■ ■ ■ 42.90 x 8.02 x 14.06
35.50 x 8.00 x 115.00					
<b>V94470</b> ■	46 750 859		45°	H	<b>VAG96203</b> ■ ■ ■ 43.00 x 8.03 x 14.08
35.30 x 8.00 x 115.00					
<b>V94065</b> ■	608 14 604		45°		<b>VAG96210</b> ■ ■ ■ 43.00 x 8.04 x 14.04
34.50 x 8.00 x 115.00					
<b>V94471</b> ■	46 783 962		45°	H	
34.50 x 8.00 x 115.00					
<b>V94590</b> ■			45°	ss H	
34.45 x 8.00 x 115.00					

<b>AY550</b> MLS, 1.600mm <b>AY560</b> MLS, 1.700mm, 1 Hole <b>AY570</b> MLS, 1.800mm, 2 Holes	<b>CY520</b> ▲	<b>FY520</b> ▲	<b>HBS257</b> ⊗ M12x1.25x218.00mm (x12)	<b>JA5036</b> ■ <b>JD228</b> ■	<b>JP064</b>	<b>HR363</b> ■	<b>NA5053</b> 30.00x42.00x7.00mm FPM



AY550, AY560, AY570







## 273

 82.00











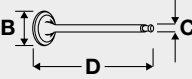

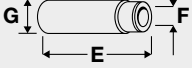





**Diesel**















<b>839 A5.000</b>	5 Cyl.	18.5:1	2387cc	<b>96-99kW (131-135)PS</b>	<b>Turbo Intercooled</b>	<b>TD14408</b>	<b>973</b>
<b>839 A5.000</b>	5 Cyl.	18.5:1	2387cc	<b>96-99kW (131-135)PS</b>	<b>Turbo Intercooled</b>	<b>TD17399</b>	<b>973</b>
<b>AR 32501</b>	5 Cyl.	18.5:1	2387cc	<b>99-100kW (135-136)PS</b>	<b>Turbo Intercooled</b>	<b>TD17400</b>	<b>975</b>

					
<b>TB639</b> 190x24	<b>TBK104</b> Component No: TB639; AE1041TP;AE1087GP	<b>CAM652</b>	<b>KIT</b>		<b>FOL104 (x10) [6]</b>

[6] Mechanical      [6] Mécanique      [6] Meccanico      [6] Mecánico

	OE	MAT.			
B x C x D	OE	MAT.			E x F x G
<b>V94064</b> 	608 14 605	 MB cr	45°	H	<b>VAG96124</b>  42.90 x 8.02 x 14.06
35.50 x 8.00 x 115.00					
<b>V94470</b> 	46 750 859	 MG cr	45°	H	<b>VAG96203</b>  43.00 x 8.03 x 14.08
35.30 x 8.00 x 115.00					
<b>V94065</b> 	608 14 604	 MD cr	45°		<b>VAG96210</b>  43.00 x 8.04 x 14.04
34.50 x 8.00 x 115.00					
<b>V94471</b> 	46 783 962	 MG cr	45°	H	
34.50 x 8.00 x 115.00					
<b>V94590</b> 		 MG cr	45°	ss H	
34.45 x 8.00 x 115.00					

							
<b>AY550</b> MLS, 1.600mm	<b>CY520</b> ▲	<b>FY520</b> ▲	<b>HBS257</b>  M12x1.25x218.00mm (x12)	<b>JA5036</b>  <b>JD228</b> 	<b>JP064</b>	<b>HR363</b> 	<b>NA5053</b> 30.00x42.00x7.00mm FPM
<b>AY560</b> MLS, 1.700mm, 1 Hole							
<b>AY570</b> MLS, 1.800mm, 2 Holes							



AY550, AY560, AY570

## 274

## 82.00

## Diesel



839 A6.000 Euro 3 (D3)

5 Cyl.

18.45:1

2387cc

103kW (140)PS

Turbo Intercooled

TD18819

976

<b>TB639</b> 190x24	<b>TBK104</b> Component No: TB639; AE1041TP;AE1087GP	<b>CAM652</b>	<b>KIT</b>	<b>FOL104</b> (x10) [6]

[6] Mechanical

[6] Mécanique

[6] Meccanico

[6] Mecánico

	OE	MAT.		
B x C x D				E x F x G
<b>V94064</b> ■ 35.50 x 8.00 x 115.00 →12/00	608 14 605		45° H	<b>VAG96203</b> ■ ■ 43.00 x 8.03 x 14.08
<b>V94470</b> ■ 35.30 x 8.00 x 115.00 01/01→	46 750 859		45° H	<b>VAG96210</b> ■ ■ 43.00 x 8.04 x 14.04
<b>V94065</b> ■ 34.50 x 8.00 x 115.00	608 14 604		45°	
<b>V94471</b> ■ 34.50 x 8.00 x 115.00	46 783 962		45° H	
<b>V94590</b> ■ 34.45 x 8.00 x 115.00			45° ss H	

<b>AA5780</b> MLS, 0.820mm	<b>CA5780</b> ▲	<b>HBS257</b> Ⓢ M12x1.25x218.00mm (x12)	<b>JA5036</b> ■ <b>JD228</b> ■	<b>JM5029</b> (Elastomer)	<b>HR363</b> ■	<b>NA5053</b> 30.00x42.00x7.00mm FPM

<b>AA5780</b>	<b>AA5790</b>	<b>AA5800</b>



839 A6.000 Euro 3 (D3)

5 Cyl.

18.45:1

2387cc

103kW (140)PS

Turbo Intercooled

TD15631

977

<b>TB639</b> 190x24	<b>TBK104</b> Component No: TB639; AE1041TP;AE1087GP	<b>CAM652</b>		<b>FOL104</b> (x10) [6]

[6] Mechanical

[6] Mécanique

[6] Meccanico

[6] Mecánico

	OE	MAT.		
B x C x D				E x F x G
<b>V94064</b> ■	608 14 605		45°	<b>VAG96124</b> ■ ■ ■
35.50 x 8.00 x 115.00		MB cr		42.90 x 8.02 x 14.06
<b>V94470</b> ■	46 750 859		45°	<b>VAG96203</b> ■ ■ ■
35.30 x 8.00 x 115.00		MG cr		43.00 x 8.03 x 14.08
<b>V94065</b> ■	608 14 604		45°	<b>VAG96210</b> ■ ■ ■
34.50 x 8.00 x 115.00		MD cr		43.00 x 8.04 x 14.04
<b>V94471</b> ■	46 783 962		45°	
34.50 x 8.00 x 115.00		MG cr		
<b>V94590</b> ■			45° ss	
34.45 x 8.00 x 115.00		MG cr		

<b>AA5780</b> MLS, 0.820mm	<b>CA5780</b> ▲	<b>HBS257</b> ☒ M12x1.25x218.00mm (x12)	<b>JA5036</b> ■ <b>JD228</b> ■	<b>JM5029</b> (Elastomer)	<b>HR363</b> ■	<b>NA5053</b> 30.00x42.00x7.00mm FPM



AA5780



AA5790

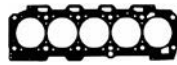

AA5800

<b>276</b>	<b>82.00</b>	<b>Diesel</b>					
<b>841 C.000</b>	5 Cyl.	18.5:1	2387cc	110kW (150)PS	Turbo Intercooled	TD16472	<b>977</b>

<b>TB639</b> 190x24 →10/05	<b>TBK104</b> →10/05 Component No: TB639; AE1041TP;AE1087GP		<b>KIT</b>		<b>FOL104</b> (x10) [6]

[6] Mechanical      [6] Mécanique      [6] Meccanico      [6] Mecánico

	OE	MAT.			
B x C x D					E x F x G
<b>V94064</b> ■	608 14 605		45°	H	<b>VAG96124</b> ■ ■ ■
35.50 x 8.00 x 115.00		MB cr			42.90 x 8.02 x 14.06
<b>V94470</b> ■	46 750 859		45°	H	<b>VAG96203</b> ■ ■ ■
35.30 x 8.00 x 115.00		MG cr			43.00 x 8.03 x 14.08
<b>V94065</b> ■	608 14 604		45°		<b>VAG96210</b> ■ ■ ■
34.50 x 8.00 x 115.00		MD cr			43.00 x 8.04 x 14.04
<b>V94471</b> ■	46 783 962		45°	H	
34.50 x 8.00 x 115.00		MG cr			
<b>V94590</b> ■			45°	ss H	
34.45 x 8.00 x 115.00		MG cr			

<b>AA5780</b> MLS, 0.820mm	<b>CA5780</b> ▲	<b>HBS257</b> Ⓢ M12x1.25x218.00mm (x12)	<b>JA5036</b> ■ <b>JD228</b> ■	<b>JM5029</b> (Elastomer)	<b>HR363</b> ■	<b>NA5053</b> 30.00x42.00x7.00mm FPM

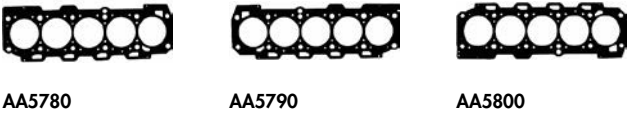

AA5780

AA5790

AA5800

# FIAT GROUP

**277**



**82.00**

**Diesel**



**841 C000**      5 Cyl.      18.5:1      2387cc      **110kW (150)PS**      **Turbo Intercooled**      **TD16383**      **976**

<b>TB639</b> 190x24	<b>TBK104</b> Component No: TB639; AE1041TP;AE1087GP				<b>FOL104</b> (x10) [6]

[6] Mechanical      [6] Mécanique      [6] Meccanico      [6] Mecánico

B x C x D	E x F x G
<b>V94064</b> ■ 35.50 x 8.00 x 115.00 →12/00	<b>VAG96203</b> ■ ■ ■ 43.00 x 8.03 x 14.08
<b>V94470</b> ■ 35.30 x 8.00 x 115.00 01/01→	<b>VAG96210</b> ■ ■ ■ 43.00 x 8.04 x 14.04
<b>V94065</b> ■ 34.50 x 8.00 x 115.00	
<b>V94471</b> ■ 34.50 x 8.00 x 115.00	
<b>V94590</b> ■ 34.45 x 8.00 x 115.00	

<b>AA5780</b> MLS, 0.820mm <b>AA5790</b> MLS, 0.920mm <b>AA5800</b> MLS, 1.020mm	<b>CA5780</b> ▲		<b>HBS257</b> ☼ M12x1.25x218.00mm (x12)	<b>JA5036</b> ■ <b>JD228</b> ■	<b>JM5029</b> (Elastomer)	<b>HR363</b> ■	<b>NA5053</b> 30.00x42.00x7.00mm FPM <b>NA5163</b> 32.00x47.00x10.00mm FPM

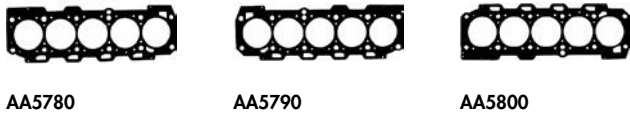

**278**



**82.00**

**Diesel**









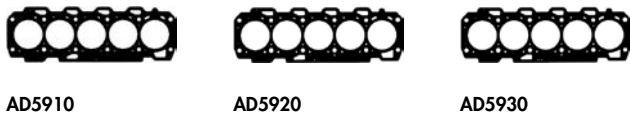











**841 G.000**      5 Cyl.      2387cc      **129kW (175)PS**      **Turbo Intercooled**      **TD18292**      **978**



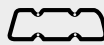

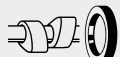





<b>TB725</b> 198x24 <b>TB579</b> 97x15 Driven unit: balance shaft					<b>FOL187</b> (x20)



















<b>AD5910</b> MLS, 0.820mm <b>AD5920</b> MLS, 0.920mm <b>AD5930</b> MLS, 1.020mm	<b>CD5910</b>		<b>HBS371</b> ☼ M12x1.25x225.00mm (x12)		<b>JM7117</b> (Steel)		<b>NA5163</b> 32.00x47.00x10.00mm FPM





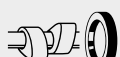





<b>279</b>	 <b>82.00</b>	<b>Diesel</b>				
<b>841 G.000</b>	5 Cyl.	2387cc	<b>129kW (175)PS</b>	<b>Turbo Intercooled</b>	<b>TD18317</b>	<b>979</b>
						
<b>TB725</b> 198x24					<b>FOL187 (x20)</b>	









							
<b>AD5190</b> Fibre Composite <b>AD5920</b> MLS, 0.920mm <b>AD5930</b> MLS, 1.020mm	<b>CD5910</b>		<b>HBS371</b>  M12x1.25x225.00mm (x12)		<b>JM7117</b> (Steel)		<b>NA5163</b> 32.00x47.00x10.00mm FPM
							
<b>AD5190</b>	<b>AD5920</b>	<b>AD5930</b>					



<b>280</b>	 <b>82.00</b>	<b>Diesel</b>					
<b>841 H.000</b>	5 Cyl.	2387cc	<b>129kW (175)PS</b>	<b>Turbo Intercooled</b>	<b>TD20953</b>	<b>981</b>	
							
					<b>JM7117</b> (Steel)		

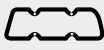

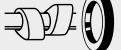

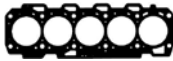





<b>281</b>	 <b>82.00</b>	<b>Diesel</b>					
<b>841 H.000</b>	5 Cyl.	2387cc	<b>129kW (175)PS</b>	<b>Turbo Intercooled</b>	<b>TD18293</b>	<b>980</b>	
							
<b>TB725</b> 198x24					<b>FOL187 (x20)</b>		
							
<b>AD5910</b> MLS, 0.820mm <b>AD5920</b> MLS, 0.920mm <b>AD5930</b> MLS, 1.020mm	<b>CD5910</b>		<b>HBS371</b>  M12x1.25x225.00mm (x12)		<b>JM7117</b> (Steel)		<b>NA5163</b> 32.00x47.00x10.00mm FPM
							
<b>AD5910</b>	<b>AD5920</b>	<b>AD5930</b>					

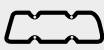

# FIAT GROUP

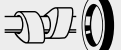















<b>282</b>	 <b>82.00</b>	<b>Diesel</b>					
<b>841 M.000</b>	5 Cyl.	18:1	2387cc	<b>120-147kW (163-200)PS</b>	<b>Turbo Intercooled</b>	<b>TD20934</b>	<b>978</b>
							
<b>TB725</b> 198x24 →06/08						<b>FOL187 (x20)</b>	

							
<b>AD5910</b> MLS, 0.820mm <b>AD5920</b> MLS, 0.920mm <b>AD5930</b> MLS, 1.020mm	<b>CD5910</b>		<b>HBS371</b> ☒ M12x1.25x225.00mm (x12)		<b>JM7117</b> (Steel)		<b>NA5163</b> 32.00x47.00x10.00mm FPM
							
<b>AD5910</b>	<b>AD5920</b>	<b>AD5930</b>					

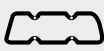



















<b>283</b>	 <b>82.00</b>	<b>Diesel</b>					
<b>841 M.000</b>	5 Cyl.	18:1	2387cc	<b>120-147kW (163-200)PS</b>	<b>Turbo Intercooled</b>	<b>TD19057</b>	<b>982</b>
<b>841 N.000</b>	5 Cyl.		2387cc	<b>120kW (163)PS</b>	<b>Turbo Intercooled</b>	<b>TD19058</b>	<b>983</b>



















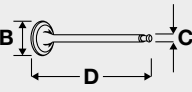





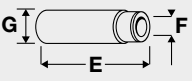









							
<b>AD5190</b> Fibre Composite <b>AD5920</b> MLS, 0.920mm <b>AD5930</b> MLS, 1.020mm	<b>CD5910</b>		<b>HBS371</b> ☒ M12x1.25x225.00mm (x12)		<b>JM7117</b> (Steel)		<b>NA5163</b> 32.00x47.00x10.00mm FPM
							
<b>AD5190</b>	<b>AD5920</b>	<b>AD5930</b>					

<b>284</b>	 <b>82.00</b>	<b>Diesel</b>					
<b>841 P.000</b>	5 Cyl.		2387cc	<b>136kW (185)PS</b>	<b>Turbo Intercooled</b>	<b>TD20954</b>	<b>985</b>

							
<b>TB790</b> 199x24						<b>FOL187 (x20)</b>	
							
<b>AG7410</b> MLS, 0.820mm, 0 Holes 06/04→ <b>AG7420</b> MLS, 0.920mm, 1 Hole 06/04→ <b>AG7430</b> MLS, 1.020mm, 2 Holes 06/04→					<b>JM7117</b> (Steel)		
							
<b>AG7410</b>	<b>AG7420</b>	<b>AG7430</b>					



<b>285</b>	 <b>82.00</b>	<b>Diesel</b>					
<b>936 B.000</b>	5 Cyl.	2387cc	<b>136kW (185)PS</b>	<b>Turbocharged</b>	<b>TD20761</b>	<b>986</b>	
							
<b>TB790</b> 199x24 →06/08					<b>FOL187</b> (x20)		
							
<b>AG7410</b> MLS, 0.820mm, 0 Holes <b>AG7420</b> MLS, 0.920mm, 1 Hole <b>AG7430</b> MLS, 1.020mm, 2 Holes	<b>CG7410</b>	<b>HBS371</b>  M12x1.25x225.00mm (x12)		<b>JM7117</b> (Steel)			
							
<b>AG7410</b>	<b>AG7420</b>	<b>AG7430</b>					

<b>286</b>	 <b>82.00</b>	<b>Diesel</b>					
<b>939 A3.000</b>	5 Cyl.	2387cc	<b>147kW (200)PS</b>	<b>Turbo Intercooled</b>	<b>TD18450</b>	<b>987</b>	
							
<b>TB790</b> 199x24					<b>FOL187</b> (x20)		
							
<b>V94588</b>  27.90 x 6.00 x 114.00 →06/06	46 802 049	 MB cr	45°	Y	H		
<b>V98005</b>  28.00 x 5.00 x 114.40 07/06→	55206431	 MB cr	45°				
<b>V94589</b>  25.80 x 6.00 x 114.30 →06/06	46 787 902	 MG cr	45°		H		
<b>V98006</b>  24.50 x 5.00 x 114.40 07/06→	55205183	 MG cr	45°				
							
<b>AG7410</b> MLS, 0.820mm, 0 Holes 06/04→	<b>CG7410</b> 06/04→	<b>HBS371</b>  M12x1.25x225.00mm (x12)		<b>JM7117</b> (Steel)			
<b>AG7420</b> MLS, 0.920mm, 1 Hole 06/04→							
<b>AG7430</b> MLS, 1.020mm, 2 Holes 06/04→							
							
<b>AG7410</b>	<b>AG7420</b>	<b>AG7430</b>					

# FIAT GROUP

## 287



82.00

Diesel



939 A3.000 Euro 4 (D4)

5 Cyl.

17:1

2387cc

147-154kW (200-209)PS

Turbo Intercooled

TD18474

988

<b>TB790</b> 199x24 →08/07				<b>FOL187</b> (x20)	

 B x C x D	OE	MAT.				 G x F x G
<b>V94588</b> ■ 27.90 x 6.00 x 114.00 Eng.→5553217	46 802 049	 MB cr	45°	Y	H	
<b>V98005</b> ■ 28.00 x 5.00 x 114.40 Eng.5553218→	55206431	 MB cr	45°			
<b>V94589</b> ■ 25.80 x 6.00 x 114.30 Eng.→5553217	46 787 902	 MG cr	45°		H	
<b>V98006</b> ■ 24.50 x 5.00 x 114.40 Eng.5553218→	55205183	 MG cr	45°			

<b>AG7410</b> MLS, 0.820mm, 0 Holes 06/04→	<b>CG7410</b> 06/04→	<b>HBS371</b> ☒ M12x1.25x225.00mm (x12)	<b>JM7117</b> (Steel)
<b>AG7420</b> MLS, 0.920mm, 1 Hole 06/04→			
<b>AG7430</b> MLS, 1.020mm, 2 Holes 06/04→			

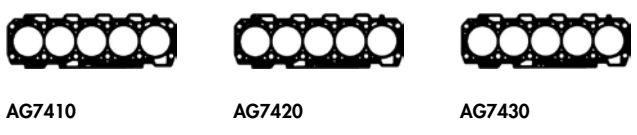

AG7410                      AG7420                      AG7430

## 288



82.00

Diesel



939 A9.000

5 Cyl.

17:1

2387cc

154kW (210)PS

Turbo Intercooled

TD20935

989

<b>TB790</b> 199x24				<b>FOL187</b> (x20)	

<b>AG7410</b> MLS, 0.820mm, 0 Holes 06/04→	<b>CG7410</b>	<b>HBS371</b> ☒ M12x1.25x225.00mm (x12)	<b>JM7117</b> (Steel)
<b>AG7420</b> MLS, 0.920mm, 1 Hole 06/04→			
<b>AG7430</b> MLS, 1.020mm, 2 Holes 06/04→			



AG7410                      AG7420                      AG7430

<b>289</b>	<b>82.00</b>	<b>Diesel</b>					
<b>AR 32501</b>	5 Cyl.	2387cc	<b>99-100kW (135-136)PS</b>	<b>Turbo Intercooled</b>	<b>TD9770</b>	<b>973</b>	

<b>TB639</b> 190x24	<b>TBK104</b> Component No: TB639; AE1041TP;AE1087GP	<b>CAM652</b>		<b>FOL104</b> (x10) [6]

[6] Mechanical      [6] Mécanique      [6] Meccanico      [6] Mecánico

	OE	MAT.			
B x C x D					E x F x G
<b>V94064</b> ■	608 14 605		45°	H	<b>VAG96203</b> ■ ■
35.50 x 8.00 x 115.00 →12/00		MB cr			43.00 x 8.03 x 14.08
<b>V94470</b> ■	46 750 859		45°	H	
35.30 x 8.00 x 115.00 01/01→		MG cr			
<b>V94065</b> ■	608 14 604		45°		
34.50 x 8.00 x 115.00		MD cr			
<b>V94471</b> ■	46 783 962		45°	H	
34.50 x 8.00 x 115.00		MG cr			
<b>V94590</b> ■			45°	ss H	
34.45 x 8.00 x 115.00		MG cr			

<b>AY550</b> MLS, 1.600mm <b>AY560</b> MLS, 1.700mm, 1 Hole	<b>CY520</b> ▲	<b>FY520</b> ▲	<b>HBS257</b> Ⓢ M12x1.25x218.00mm (x12)	<b>JA5036</b> ■ <b>JD228</b> ■	<b>NA5053</b> 30.00x42.00x7.00mm FPM <b>NA5163</b> 32.00x47.00x10.00mm FPM



AY550, AY560

## 290

### 82.00

### Diesel



AR 34202      5 Cyl.      18.45:1      2387cc      100kW (136)PS      Turbo Intercooled      TD11604      973

<b>TB639</b> 190x24	<b>TBK104</b> Component No: TB639; AE1041TP;AE1087GP		<b>KIT</b>		<b>FOL104</b> (x10) [6]

[6] Mechanical      [6] Mécanique      [6] Meccanico      [6] Mecánico

	OE	MAT.			
B x C x D					E x F x G
<b>V94064</b> ■ 35.50 x 8.00 x 115.00 →12/00	608 14 605	 MB cr	45°	H	<b>VAG96203</b> ■ ■ ■ 43.00 x 8.03 x 14.08
<b>V94470</b> ■ 35.30 x 8.00 x 115.00 01/01→	46 750 859	 MG cr	45°	H	<b>VAG96210</b> ■ ■ ■ 43.00 x 8.04 x 14.04
<b>V94065</b> ■ 34.50 x 8.00 x 115.00	608 14 604	 MD cr	45°		
<b>V94471</b> ■ 34.50 x 8.00 x 115.00	46 783 962	 MG cr	45°	H	
<b>V94590</b> ■ 34.45 x 8.00 x 115.00		 MG cr	45°	ss H	

<b>AY550</b> MLS, 1.600mm <b>AY560</b> MLS, 1.700mm, 1 Hole <b>AY570</b> MLS, 1.800mm, 2 Holes	<b>CY520</b> ▲	<b>FY520</b> ▲	<b>HBS257</b> ☉ M12x1.25x218.00mm (x12)	<b>JA5036</b> ■ (Metal) →01/00 <b>JD5810</b> ■ 02/00→ <b>JD228</b> ■	<b>JP064</b>	<b>HR363</b> ■	<b>NA5053</b> 30.00x42.00x7.00mm FPM



AY550, AY560, AY570

<b>291</b>	<b>82.00</b>	<b>Diesel</b>	
AR 36202	5 Cyl.	2387cc	103kW (140)PS
			<b>FOL104 (x10) [6]</b>

[6] Mechanical      [6] Mécanique      [6] Meccanico      [6] Mecánico

B x C x D	OE	MAT.	45°			E x F x G
<b>V94064</b>	608 14 605	MB cr	45°	H		<b>VAG96203</b>
35.50 x 8.00 x 115.00 →12/00						43.00 x 8.03 x 14.08
<b>V94470</b>	46 750 859	MG cr	45°	H		
35.30 x 8.00 x 115.00 01/01→						
<b>V94065</b>	608 14 604	MD cr	45°			
34.50 x 8.00 x 115.00						
<b>V94471</b>	46 783 962	MG cr	45°	H		
34.50 x 8.00 x 115.00						
<b>V94590</b>		MG cr	45°	ss	H	
34.45 x 8.00 x 115.00						

			<b>HBS257</b>				
			M12x1.25x218.00mm (x12)				

<b>292</b>	<b>82.20</b>	<b>Diesel</b>	
WJY (DW8)	4 Cyl.	23:1	1868cc
			51kW (69)PS
			TD21266
			991

B x C x D	OE	MAT.	45°			E x F x G
<b>V91144</b>	96 005 391	MB	45°	H		
38.50 x 8.00 x 112.50						
<b>V94154</b>	0948.94	MB	45°	H		
38.50 x 8.00 x 112.40						
<b>V91145</b>	96 137 360	MD cr	45°			
33.00 x 8.00 x 112.00						

				<b>JD6023</b> (x2)			<b>NF841</b>
				0.8mm			35.00x50.00x8.00mm FPM

<b>293</b>	<b>82.20</b>	<b>Diesel</b>	
WJY (DW8B)	4 Cyl.	23:1	1868cc
			51kW (69)PS
			TD22240
			991

				<b>JD6023</b> (x2)			<b>NF841</b>
				0.8mm			35.00x50.00x8.00mm FPM

# FIAT GROUP

**294**

 **82.20**

**Diesel**



WJZ (DW8)

4 Cyl.







23:1

1868cc

51-52kW (69-71)PS





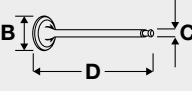
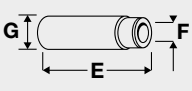

TD16300

**992**

					
<b>TB631</b> 140x25.4 08/98→10/06	<b>TBK105</b> 08/98→10/06 Component No: TB631; AE1165TP;AE1166GP		<b>KIT</b>		<b>FOL73</b> (x8) [6] <b>FOL150</b> (x8) [6]

[6] Mechanical [6] Mécanique [6] Meccanico [6] Mecánico

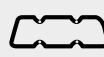
	
B x C x D	E x F x G
<b>V91144</b> ■ 38.50 x 8.00 x 112.50	<b>VAG96100</b> ■ ■ ■ 48.00 x 8.02 x 14.37
<b>V94154</b> ■ 38.50 x 8.00 x 112.40	
<b>V91145</b> ■ 33.00 x 8.00 x 112.00	

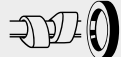
						
<b>AA5830</b> Steel Elastomer, 1.260mm, 1 Hole ⊖(0.51)→(0.54) mm	<b>CA5830</b> ▲	<b>HBS084</b> ⊕ M12x1.50x120.00mm (x10) →Eng.08469	<b>JD6023</b> ■ (x2) 0.8mm <b>HA5008</b> ■ ■ ■ <b>JD5192</b> ■ (x2)	<b>JM5088</b> ■ (Elastomer) <b>JM5089</b> ■ (Elastomer)	<b>HR569</b> ■	<b>NF841</b> 35.00x50.00x8.00mm FPM
<b>AA5840</b> Steel Elastomer, 1.300mm, 2 Holes ⊖(0.55)→(0.58) mm		<b>HBS245</b> ⊕ M12x1.50x125.00mm (x10) Eng.08470→				
<b>AA5850</b> Steel Elastomer, 1.340mm, 3 Holes ⊖(0.59)→(0.62) mm						
<b>AA5860</b> Steel Elastomer, 1.380mm, 4 Holes ⊖(0.63)→(0.66) mm						
<b>AA5870</b> Steel Elastomer, 1.420mm, 5 Holes ⊖(0.670)→(0.7) mm						
<b>AA5880</b> Steel Elastomer, 1.460mm, 6 Holes ⊖(0.71)→(0.75) mm						



AA5830, AA5840, AA5850, AA5860, AA5870, AA5880

**295**

 **82.60**

**Diesel**



149 B2.000

4 Cyl.







20:1

1697cc







42kW (57)PS

TD16864

**995**

					
<b>TB337</b> 168x22	<b>TBK040</b> Component No: TB337; AE1004TP;AE1005GP		<b>KIT</b>		<b>FOL104</b> (x8) [6]

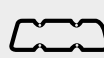
[6] Mechanical [6] Mécanique [6] Meccanico [6] Mecánico

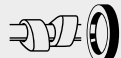
						
	<b>DV680</b> ▲	<b>HBS095</b> ⊗ M12x1.25x133.00mm (x10)				

<b>296</b>	<b>82.60</b>	<b>Diesel</b>			
149 B4.000	4 Cyl.	20:1	1697cc	42-45kW (57-61)PS	TD968 <b>994</b>
<b>TB306</b> 170x22 06/88 →					<b>FOL104</b> (x8) [6]
[6] Mechanical	[6] Mécanique	[6] Meccanico	[6] Mecánico		

B x C x D	E x F x G
OE	
MAT.	
45°	H
<b>V91295</b> ■	<b>VAG92366</b> ■ ■ ■
37.50 x 8.00 x 117.00	46.50 x 8.00 x 14.10
<b>V91767</b> ■	
37.50 x 8.00 x 117.00	
<b>V91392</b> ■	
33.50 x 8.00 x 116.70	
5 990 532	
5 990 532	
5 990 533	
MB cr	
MB cr	
MD cr	

<b>AC5140</b> MLS, 1.660mm <b>AC5150</b> MLS, 1.760mm <b>BT230</b> Fibre Composite, 1.800mm, 1 Notch <b>AC5180</b> MLS, 1.860mm <b>BT240</b> Fibre Composite, 1.950mm, 2 Notches <b>AC5160</b> MLS, 1.960mm	<b>DV680</b> ▲	<b>GV680</b> ▲	<b>HBS095</b> ⊗ M12x1.25x133.00mm (x10)	<b>JC738</b>	<b>JN459</b>	<b>HR596</b> ■	<b>NA5187</b> 30.00x52.00x7.00mm ACM



AC5140, AC5150, AC5180, AC5160



BT230, BT240

<b>297</b>	<b>82.60</b>	<b>Diesel</b>			
149 B4.046	4 Cyl.	20:1	1697cc	42-44kW (57-60)PS	TD969 <b>993</b>
<b>BT230</b> Fibre Composite, 1.800mm, 1 Notch <b>BT240</b> Fibre Composite, 1.950mm, 2 Notches	<b>GV680</b> ▲	<b>HBS095</b> ⊗ M12x1.25x133.00mm (x10)	<b>JC738</b>	<b>JN459</b>	<b>HR596</b> ■

**BT230** Fibre Composite, 1.800mm, 1 Notch  
**BT240** Fibre Composite, 1.950mm, 2 Notches



BT230, BT240

# FIAT GROUP







**298**

 **82.60**

**Diesel**



**138 C.000**      4 Cyl.      20:1      1698cc      **44kW (60)PS**      **TD925**      **993**

			 <b>KIT</b>		
<b>TB349</b> 141x25.4					

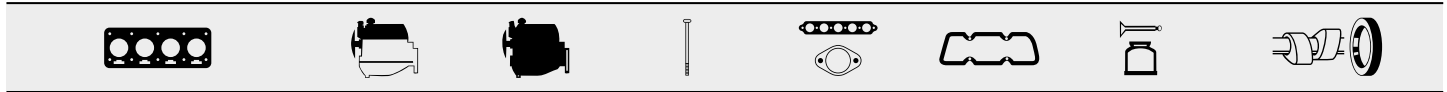

<b>AC5140</b> MLS, 1.660mm <b>AC5150</b> MLS, 1.760mm <b>BT230</b> Fibre Composite, 1.800mm, 1 Notch <b>AC5180</b> MLS, 1.860mm <b>BT240</b> Fibre Composite, 1.950mm, 2 Notches <b>AC5160</b> MLS, 1.960mm	<b>DV680</b> ▲	<b>GV680</b> ▲	<b>HBS011</b> ① M12x1.25x119.00mm (x12) <b>HBS095</b> ② M12x1.25x133.00mm (x10)	<b>JC738</b>	<b>JN459</b>	<b>HR596</b> ③	
--	----------------	----------------	--	--------------	--------------	----------------	--

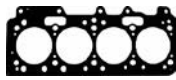

AC5140, AC5150, AC5180, AC5160

BT230, BT240







**299**

 **82.60**

**Diesel**





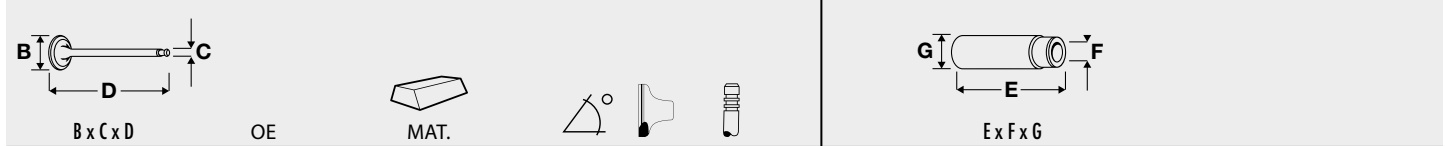

**146 B2.000**      4 Cyl.      20.5:1      1698cc      **42-44kW (57-60)PS**      **TD949**      **994**

			 <b>KIT</b>		
<b>TB337</b> 168x22	<b>TBK040</b> Component No: TB337; AE1004TP;AE1005GP				<b>FOL104</b> (x8) [6]

[6] Mechanical      [6] Mécanique      [6] Meccanico      [6] Mecánico



	OE	MAT.	Angle	Material
<b>V91295</b> ■■ 37.50 x 8.00 x 117.00	5 990 532		45°	H
<b>V91767</b> ■■ 37.50 x 8.00 x 117.00	5 990 532		45°	H
<b>V91392</b> ■■ 33.50 x 8.00 x 116.70	5 990 533		45°	H

<b>VAG92366</b> ■■ ■■ 46.50 x 8.00 x 14.10	
---	---

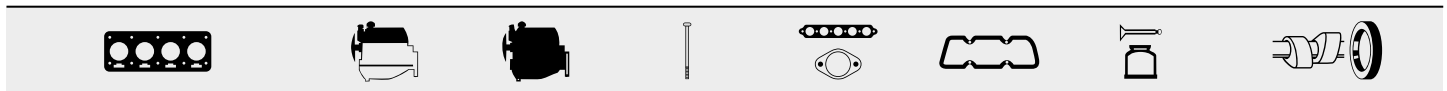

<b>AG6060</b> MLS, 1.200mm <b>AG7300</b> MLS, 1.300mm <b>BT230</b> Fibre Composite, 1.800mm, 1 Notch <b>BT240</b> Fibre Composite, 1.950mm, 2 Notches	<b>DV680</b> ▲	<b>GV680</b> ▲	<b>HBS095</b> ② M12x1.25x133.00mm (x10)	<b>JC738</b>	<b>JN459</b>	<b>HR596</b> ③	<b>NA5187</b> 30.00x52.00x7.00mm ACM
--	----------------	----------------	--	--------------	--------------	----------------	---



AG6060

AG7300

BT230, BT240



<b>300</b>	<b>82.60</b>	<b>Diesel</b>							
<b>146 D7.000</b>	4 Cyl.	20:1	1698cc	<b>46kW (63)PS</b>	<b>Turbocharged</b>	<b>TD9472</b>	<b>996</b>		

<b>TB337</b> 168x22	<b>TBK040</b> Component No: TB337; AE1004TP;AE1005GP								<b>FOL104 (x8) [6]</b>

[6] Mechanical      [6] Mécanique      [6] Meccanico      [6] Mecánico

<b>B x C x D</b>	<b>E x F x G</b>
<b>V91295</b> ■ 37.50 x 8.00 x 117.00	<b>VAG92366</b> ■ ■ ■ 46.50 x 8.00 x 14.10
<b>V91767</b> ■ 37.50 x 8.00 x 117.00	
<b>V91392</b> ■ 33.50 x 8.00 x 116.70	
OE: 5 990 532	
MAT. MB cr	
45°	
H	

<b>BR680</b> Graphite Composite, 1.650mm	<b>DV680</b> ▲	<b>GV680</b> ▲	<b>HBS095</b> ⊗ M12x1.25x133.00mm (x10)	<b>JC738</b>	<b>JN459</b>	<b>HR596</b> ■	<b>NA5187</b> 30.00x52.00x7.00mm ACM
<b>BV680</b> Fibre Composite, 1.670mm, 0 Notches							
<b>BV690</b> Fibre Composite, 1.750mm, 1 Notch							
<b>BV700</b> Fibre Composite, 1.850mm, 2 Notches							
<b>BW980</b> Fibre Composite, 1.930mm, 3 Notches							



BR680



BV680, BV690, BV700, BW980

## 301

## 82.60

## Diesel



149 B3.000

4 Cyl.

20.5:1

1698cc

44kW (60)PS

TD967

994

<b>TB337</b> 168x22	<b>TBK040</b> Component No: TB337; AE1004TP;AE1005GP	<b>CAM641</b>		<b>FOL104 (x8) [6]</b>

[6] Mechanical

[6] Mécanique

[6] Meccanico

[6] Mecánico

<p><b>V91295</b> ■ 37.50 x 8.00 x 117.00</p> <p><b>V91767</b> ■ 37.50 x 8.00 x 117.00</p> <p><b>V91392</b> ■ 33.50 x 8.00 x 116.70</p>	<p><b>VAG92366</b> ■ ■ ■ 46.50 x 8.00 x 14.10</p>
<p>B x C x D</p> <p>OE</p> <p>MAT.</p> <p>45°</p> <p>H</p>	<p>E x F x G</p>

<p><b>AC5140</b> MLS, 1.660mm</p> <p><b>AC5150</b> MLS, 1.760mm</p> <p><b>BT230</b> Fibre Composite, 1.800mm, 1 Notch</p> <p><b>AC5180</b> MLS, 1.860mm</p> <p><b>BT240</b> Fibre Composite, 1.950mm, 2 Notches</p> <p><b>AC5160</b> MLS, 1.960mm</p>	<b>DV680</b> ▲	<b>GV680</b> ▲	<b>HBS095</b> ☒ M12x1.25x133.00mm (x10)	<b>JC738</b>	<b>JN459</b>	<b>HR596</b> ■	<b>NA5187</b> 30.00x52.00x7.00mm ACM

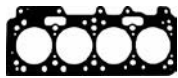

AC5140, AC5150, AC5180, AC5160



BT230, BT240

<b>302</b>	<b>82.60</b>	<b>Diesel</b>					
<b>176 A3.000</b>	4 Cyl.	20.3:1	1698cc	<b>51-53kW (69-72)PS</b>	<b>Turbocharged</b>	<b>TD1033</b>	<b>997</b>
<b>176 B7.000</b>	4 Cyl.	19.1:1	1698cc	<b>46-47kW (63-64)PS</b>	<b>Turbocharged</b>	<b>TD5493</b>	<b>998</b>

<b>TB337</b> 168x22	<b>TBK040</b> Component No: TB337; AE1004TP;AE1005GP		<b>KIT</b>		<b>FOL104 (x8) [6]</b>

[6] Mechanical      [6] Mécanique      [6] Meccanico      [6] Mecánico

<b>B x C x D</b>	<b>OE</b>	<b>MAT.</b>			
<b>V91295</b> ■	5 990 532		45°	H	<b>VAG92366</b> ■ ■ ■ 46.50 x 8.00 x 14.10
37.50 x 8.00 x 117.00		MB cr			
<b>V91767</b> ■	5 990 532		45°	H	
37.50 x 8.00 x 117.00		MB cr			
<b>V91392</b> ■	5 990 533		45°		
33.50 x 8.00 x 116.70		MD cr			

<b>BR680</b> Graphite Composite, 1.650mm	<b>DV680</b> ▲	<b>GV680</b> ▲	<b>HBS095</b> ⊗ M12x1.25x133.00mm (x10)	<b>JC738</b>	<b>JN459</b>	<b>HR596</b> ■	<b>NA5187</b> 30.00x52.00x7.00mm ACM
<b>AC5140</b> MLS, 1.660mm							
<b>BV680</b> Fibre Composite, 1.670mm, 0 Notches							
<b>BV690</b> Fibre Composite, 1.750mm, 1 Notch							
<b>AC5150</b> MLS, 1.760mm							
<b>BV700</b> Fibre Composite, 1.850mm, 2 Notches							
<b>AC5180</b> MLS, 1.860mm							
<b>BW980</b> Fibre Composite, 1.930mm, 3 Notches							
<b>AC5160</b> MLS, 1.960mm							

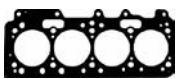

AC5140, AC5150, AC5180, AC5160



BR680



BV680, BV690, BV700, BW980



176 A5.000

4 Cyl.

19.1:1

1698cc

52-59kW (71-80)PS

Turbocharged

TD1035

998

<b>TB337</b> 168x22	<b>TBK040</b> Component No: TB337; AE1004TP;AE1005GP	<b>CAM417</b>	<b>KIT</b>	<b>FOL104 (x8) [6]</b>

[6] Mechanical

[6] Mécanique

[6] Meccanico

[6] Mecánico

B x C x D	E x F x G
<b>V91295</b> ■ 37.50 x 8.00 x 117.00	<b>VAG92366</b> ■ ■ ■ 46.50 x 8.00 x 14.10
<b>V91767</b> ■ 37.50 x 8.00 x 117.00	
<b>V91392</b> ■ 33.50 x 8.00 x 116.70	

<b>BR680</b> Graphite Composite, 1.650mm <b>AC5140</b> MLS, 1.660mm <b>BV680</b> Fibre Composite, 1.670mm, 0 Notches <b>BV690</b> Fibre Composite, 1.750mm, 1 Notch <b>AC5150</b> MLS, 1.760mm <b>BV700</b> Fibre Composite, 1.850mm, 2 Notches <b>AC5180</b> MLS, 1.860mm <b>BW980</b> Fibre Composite, 1.930mm, 3 Notches <b>AC5160</b> MLS, 1.960mm	<b>DV680</b> ▲	<b>GV680</b> ▲	<b>HBS095</b> ☒ M12x1.25x133.00mm (x10)	<b>JC738</b>	<b>JN459</b>	<b>HR596</b> ■	<b>NA5187</b> 30.00x52.00x7.00mm ACM



AC5140, AC5150, AC5180, AC5160

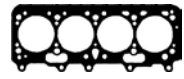

BR680



BV680, BV690, BV700, BW980

<b>304</b>	<b>82.60</b>	<b>Diesel</b>				
<b>176 B3.000</b>	4 Cyl.	20.5:1	1698cc	<b>42kW (57)PS</b>	<b>TD9477</b>	<b>994</b>

<b>TB337</b> 168x22	<b>TBK040</b> Component No: TB337; AE1004TP;AE1005GP	<b>CAM417</b>			<b>FOL104 (x8) [6]</b>

[6] Mechanical [6] Mécanique [6] Meccanico [6] Mecánico

<b>B x C x D</b>	<b>E x F x G</b>
<b>V91295</b> ■ 37.50 x 8.00 x 117.00	<b>VAG92366</b> ■ ■ ■ 46.50 x 8.00 x 14.10
<b>V91767</b> ■ 37.50 x 8.00 x 117.00	
<b>V91392</b> ■ 33.50 x 8.00 x 116.70	
OE: 5 990 532	
MAT. MB cr	
45°	
H	
5 990 532	
MB cr	
45°	
H	
5 990 533	
MD cr	
45°	

<b>BT230</b> Fibre Composite, 1.800mm, 1 Notch <b>BT240</b> Fibre Composite, 1.950mm, 2 Notches	<b>DV680</b> ▲	<b>GV680</b> ▲	<b>HBS095</b> ⊗ M12x1.25x133.00mm (x10)	<b>JC738</b>	<b>JN459</b>	<b>HR596</b> ■	<b>NA5187</b> 30.00x52.00x7.00mm ACM



BT230, BT240

<b>305</b>	<b>82.60</b>	<b>Diesel</b>				
<b>831 D.000</b>	4 Cyl.	21:1	1911cc	<b>48kW (65)PS</b>	<b>TD1813</b>	<b>1000</b>

<b>TB351</b> 126x25.4 <b>TB352</b> 57x19 Driven unit: injection pump					<b>FOL104 (x8) [6]</b>

[6] Mechanical [6] Mécanique [6] Meccanico [6] Mecánico

<b>B x C x D</b>	<b>E x F x G</b>
<b>V91767</b> ■ 37.50 x 8.00 x 117.00	<b>VAG92366</b> ■ ■ ■ 46.50 x 8.00 x 14.10
<b>V91392</b> ■ 33.50 x 8.00 x 116.70	
OE: 5 990 532	
MAT. MB cr	
45°	
H	
5 990 533	
MD cr	
45°	

<b>BR700</b> Graphite Composite, 1.950mm, 2 Notches	<b>DT290</b> ▲	<b>GV680</b> ▲	<b>HBS095</b> ⊗ M12x1.25x133.00mm (x10)	<b>JC738</b>	<b>JN459</b>	<b>HR363</b> ■	



BR700

## 306

## 82.60

## Diesel



149 A1.000

4 Cyl.

21:1

1929cc

48kW (65)PS

TD4378

1001

<p><b>TB186</b> 139x25.4 →7056787 for vehicles without air conditioning</p> <p><b>TB350</b> 143x25.4 7056788→ for vehicles without air conditioning</p> <p><b>TB352</b> 57x19 Driven unit: injection pump for vehicles with air conditioning</p> <p><b>TB351</b> 126x25.4 for vehicles with air conditioning</p>				<p><b>FOL104 (x8) [6]</b></p>

[6] Mechanical

[6] Mécanique

[6] Meccanico

[6] Mecánico

<p><b>V91295 ■</b> 37.50 x 8.00 x 117.00</p> <p><b>V91767 ■</b> 37.50 x 8.00 x 117.00</p> <p><b>V91392 ■</b> 33.50 x 8.00 x 116.70</p>	<p><b>OE</b> 5 990 532</p> <p><b>MAT.</b> MB cr</p> <p>45°</p> <p>H</p>	<p><b>OE</b> 5 990 532</p> <p><b>MAT.</b> MB cr</p> <p>45°</p> <p>H</p>	<p><b>VAG92366 ■ ■ ■</b> 46.50 x 8.00 x 14.10</p>

<p><b>AC5140</b> MLS, 1.660mm <b>BV680</b> Fibre Composite, 1.670mm, 0 Notches <b>BV690</b> Fibre Composite, 1.750mm, 1 Notch <b>AC5150</b> MLS, 1.760mm <b>BV700</b> Fibre Composite, 1.850mm, 2 Notches <b>AC5180</b> MLS, 1.860mm <b>BW980</b> Fibre Composite, 1.930mm, 3 Notches <b>AC5160</b> MLS, 1.960mm</p>	<b>DV680 ▲</b>	<b>GV680 ▲</b>	<b>HBS095 ☉</b> M12x1.25x133.00mm (x10)	<b>JC738</b>	<b>JN459</b>	<b>HR596 ■</b>	<b>NA5187</b> 30.00x52.00x7.00mm ACM



AC5140, AC5150, AC5180, AC5160



BV680, BV690, BV700, BW980

<b>307</b>	<b>82.60</b>	<b>Diesel</b>				
<b>149 B1.000</b>	4 Cyl.	21:1	1929cc	<b>51-52kW (70-71)PS</b>	<b>TD963</b>	<b>1001</b>
<b>TB286</b> 170x25.4						<b>FOL104 (x8) [6]</b>
[6] Mechanical	[6] Mécanique	[6] Meccanico	[6] Mecánico			

B x C x D	OE	MAT.				E x F x G
<b>V91295</b> ■	5 990 532		45°		H	<b>VAG92366</b> ■ ■ ■
37.50 x 8.00 x 117.00		MB cr				46.50 x 8.00 x 14.10
<b>V91767</b> ■	5 990 532		45°		H	
37.50 x 8.00 x 117.00		MB cr				
<b>V91392</b> ■	5 990 533		45°			
33.50 x 8.00 x 116.70		MD cr				

<b>BR680</b> Graphite Composite, 1.650mm	<b>DV680</b> ▲	<b>GV680</b> ▲	<b>HBS095</b> ⊗ M12x1.25x133.00mm (x10)	<b>JC738</b>	<b>JN459</b>	<b>HR596</b> ■	<b>NA5187</b> 30.00x52.00x7.00mm ACM
<b>BV680</b> Fibre Composite, 1.670mm, 0 Notches							
<b>BV690</b> Fibre Composite, 1.750mm, 1 Notch							
<b>BV700</b> Fibre Composite, 1.850mm, 2 Notches							
<b>BW980</b> Fibre Composite, 1.930mm, 3 Notches							





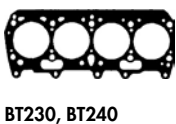





<b>308</b>	<b>82.60</b>	<b>Diesel</b>					
<b>149 B5.046</b>	4 Cyl.	20:1	1929cc	<b>44kW (60)PS</b>	<b>TD9602</b>	<b>1002</b>	
<b>TB306</b> 170x22 →07/93							
<b>BT230</b> Fibre Composite, 1.800mm, 1 Notch	<b>DT290</b> ▲		<b>HBS095</b> ⊗ M12x1.25x133.00mm (x10)			<b>HR596</b> ■	<b>NA5187</b> 30.00x52.00x7.00mm ACM
<b>BT240</b> Fibre Composite, 1.950mm, 2 Notches							











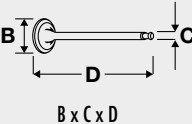

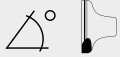

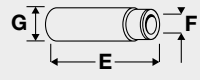

<b>309</b>	<b>82.60</b>	<b>Diesel</b>					
<b>154 B.000</b>	4 Cyl.	20:1	1929cc	<b>68kW (92)PS</b>	<b>Turbo Intercooled</b>	<b>TD21460</b>	<b>1003</b>
	<b>DT300</b> ▲	<b>GT300</b> ▲		<b>JD013</b>		<b>HR363</b> ■	<b>NA5053</b> 30.00x42.00x7.00mm FPM

# FIAT GROUP

<b>310</b>	 <b>82.60</b>	<b>Diesel</b>					
154 C6.000	4 Cyl.	18:1	1929cc	66-68kW (90-92)PS	Turbo Intercooled	TD9621	<b>1004</b>
154 D1.000	4 Cyl.	20:1	1929cc	69kW (94)PS	Turbo Intercooled	TD9622	<b>1005</b>

					
<b>TB286</b> 170x25.4			<b>KIT</b>		

				
B x C x D	OE	MAT.	45°	H
<b>V91658</b> ■ 36.50 x 8.00 x 114.00	7 597 566	 MB cr	45°	
<b>V91659</b> ■ 33.50 x 8.00 x 114.00	7 597 565	 MD cr	45°	
				<b>VAG92366</b> ■ ■ ■ 46.50 x 8.00 x 14.10

							
<b>BT300</b> Fibre Composite, 1.650mm	<b>DT300</b> ▲	<b>GT300</b> ▲	<b>HBS097</b> ☉ M12x1.25x120.00mm (x10)	<b>JD013</b>	<b>JN809</b>	<b>HR569</b> ■	<b>NA5053</b> 30.00x42.00x7.00mm FPM
<b>BT320</b> Fibre Composite, 1.950mm, 2 Notches							



BT300, BT320



<b>311</b>	<b>82.60</b>	<b>Diesel</b>					
<b>160 A6.000</b>	4 Cyl.	19.2:1	1929cc	<b>66-68kW (90-92)PS</b>	<b>Turbo Intercooled</b>	<b>TD4394</b>	<b>1006</b>

<b>TB307</b> 173x22	<b>TBK065</b> Component No: TB307; AE1061TP;AE1049GP		<b>KIT</b>		

<b>B x C x D</b>	<b>E x F x G</b>
<b>OE</b>	
<b>MAT.</b>	
<b>V91291</b>	<b>VAG92366</b>
37.50 x 8.00 x 116.50	46.50 x 8.00 x 14.10
<b>V91321</b>	
33.50 x 8.00 x 116.45	
<b>V91392</b>	
33.50 x 8.00 x 116.70	

<b>BR680</b> Graphite Composite, 1.650mm	<b>DV680</b> ▲	<b>GV680</b> ▲	<b>HBS095</b>	<b>JC738</b>	<b>JN459</b>	<b>NA5187</b>
<b>AC5140</b> MLS, 1.660mm			M12x1.25x133.00mm (x10)			30.00x52.00x7.00mm ACM
<b>BV680</b> Fibre Composite, 1.670mm, 0 Notches						
<b>BV690</b> Fibre Composite, 1.750mm, 1 Notch						
<b>AC5150</b> MLS, 1.760mm						
<b>BV700</b> Fibre Composite, 1.850mm, 2 Notches						
<b>AC5180</b> MLS, 1.860mm						
<b>BW980</b> Fibre Composite, 1.930mm, 3 Notches						
<b>AC5160</b> MLS, 1.960mm						

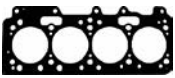

AC5140, AC5150, AC5180, AC5160



BR680



BV680, BV690, BV700, BW980

## 312



82.60

Diesel



160 A6.046

4 Cyl.

19.2:1

1929cc

66kW (90)PS

Turbo Intercooled

TD1022

1006



KIT



**TB307**  
173x22

**TBK065**  
Component No: TB307;  
AE1061TP;AE1049GP

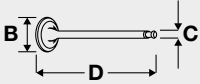

B x C x D

OE



MAT.



45°

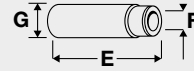

E x F x G

**V91291** ■  
37.50 x 8.00 x 116.50

7 547 158

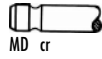

MD cr

**V91321** ■  
33.50 x 8.00 x 116.45

7 588 577

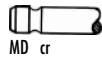

MD cr

**V91392** ■  
33.50 x 8.00 x 116.70

5 990 533

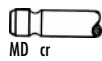

MD cr

**VAG92366** ■ ■ ■  
46.50 x 8.00 x 14.10

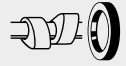
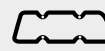

**BR680** Graphite Composite, 1.650mm

**BV680** Fibre Composite, 1.670mm, 0 Notches

**BV690** Fibre Composite, 1.750mm, 1 Notch

**AC5150** MLS, 1.760mm

**BV700** Fibre Composite, 1.850mm, 2 Notches

**AC5180** MLS, 1.860mm

**BW980** Fibre Composite, 1.930mm, 3 Notches

**AC5160** MLS, 1.960mm

**DV680** ▲

**GV680** ▲

**HBS095** ☒

M12x1.25x133.00mm (x10)

**JC738**

**JN459**

**NA5187**

30.00x52.00x7.00mm ACM

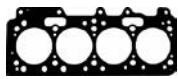

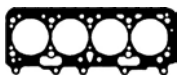

AC5150, AC5180, AC5160









BR680











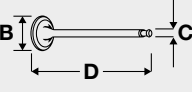
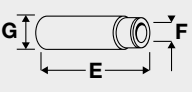





BV680, BV690, BV700, BW980

<b>313</b>	 <b>82.60</b>	<b>Diesel</b>			
<b>160 A7.000</b>	4 Cyl.	21:1	1929cc	<b>48kW (65)PS</b>	<b>TD1023 1001</b>

					
<b>TB307</b> 173x22 →05/97	<b>TBK065</b> →05/97 Component No: TB307; AE1061TP;AE1049GP		<b>KIT</b>		<b>FOL104 (x8) [6]</b>

[6] Mechanical      [6] Mécanique      [6] Meccanico      [6] Mecánico

	
B x C x D	E x F x G
OE	
MAT.	
	
	
<b>V91295</b> ■	<b>VAG92366</b> ■ ■
37.50 x 8.00 x 117.00	46.50 x 8.00 x 14.10
<b>V91767</b> ■	
37.50 x 8.00 x 117.00	
<b>V91392</b> ■	
33.50 x 8.00 x 116.70	

							
<b>AC5140</b> MLS, 1.660mm <b>AC5150</b> MLS, 1.760mm <b>BT230</b> Fibre Composite, 1.800mm, 1 Notch <b>AC5180</b> MLS, 1.860mm <b>BT240</b> Fibre Composite, 1.950mm, 2 Notches <b>AC5160</b> MLS, 1.960mm	<b>DV680</b> ▲	<b>GV680</b> ▲	<b>HBS095</b> ⊗ M12x1.25x133.00mm (x10)	<b>JC738</b>	<b>JN459</b>	<b>HR596</b> ■	<b>NA5187</b> 30.00x52.00x7.00mm ACM

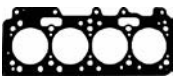

AC5140, AC5150, AC5180, AC5160



BT230, BT240

## 314

## 82.60

## Diesel



160 B6.046

4 Cyl.

1929cc

59kW (82)PS

Turbo Intercooled

TD1025

1006

<b>TB307</b> 173x22	<b>TBK065</b> Component No: TB307; AE1061TP;AE1049GP		<b>KIT</b>		<b>FOL104 (x8) [6]</b>

[6] Mechanical

[6] Mécanique

[6] Meccanico

[6] Mecánico

<b>B x C x D</b>	<b>E x F x G</b>
<b>V91291</b> ■ 37.50 x 8.00 x 116.50	<b>VAG92366</b> ■ ■ ■ 46.50 x 8.00 x 14.10
<b>V91321</b> ■ 33.50 x 8.00 x 116.45	
<b>V91392</b> ■ 33.50 x 8.00 x 116.70	

<b>BV680</b> Fibre Composite, 1.670mm, 0 Notches <b>BV690</b> Fibre Composite, 1.750mm, 1 Notch <b>BV700</b> Fibre Composite, 1.850mm, 2 Notches <b>BW980</b> Fibre Composite, 1.930mm, 3 Notches	<b>DS435</b> <b>DV680</b> ▲	<b>GV680</b> ▲	<b>HBS095</b> ☒ M12x1.25x133.00mm (x10)	<b>JC738</b>	<b>JN459</b>	<b>NA5187</b> 30.00x52.00x7.00mm ACM



BV680, BV690, BV700, BW980

<b>315</b>	<b>82.60</b>	<b>Diesel</b>	
<b>160 D1.000</b>	4 Cyl.	1929cc	<b>65-66kW (88-90)PS</b>
			<b>Turbo Intercooled</b>
			<b>TD1026 1006</b>

<b>TB307</b> 173x22	<b>TBK065</b> Component No: TB307; AE1061TP;AE1049GP		<b>KIT</b>		<b>FOL104 (x8) [6]</b>

[6] Mechanical [6] Mécanique [6] Meccanico [6] Mecánico

B x C x D	E x F x G
OE	
MAT.	
<b>V91291</b>	<b>VAG92366</b>
37.50 x 8.00 x 116.50	46.50 x 8.00 x 14.10
<b>V91321</b>	
33.50 x 8.00 x 116.45	
<b>V91392</b>	
33.50 x 8.00 x 116.70	

<b>AC5140</b> MLS, 1.660mm <b>BV680</b> Fibre Composite, 1.670mm, 0 Notches <b>BV690</b> Fibre Composite, 1.750mm, 1 Notch <b>AC5150</b> MLS, 1.760mm <b>BV700</b> Fibre Composite, 1.850mm, 2 Notches <b>AC5180</b> MLS, 1.860mm <b>BW980</b> Fibre Composite, 1.930mm, 3 Notches <b>AC5160</b> MLS, 1.960mm	<b>DV680</b> ▲	<b>GV680</b> ▲	<b>HBS095</b> Ⓢ M12x1.25x133.00mm (x10)	<b>JC738</b>	<b>JN459</b>	<b>NA5187</b> 30.00x52.00x7.00mm ACM



AC5140, AC5150, AC5180, AC5160

















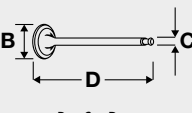

BV680, BV690, BV700, BW980

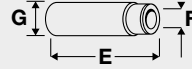









# FIAT GROUP

## 316 82.60 Diesel

160 D1.000      4 Cyl.      19.2:1      1929cc      66kW (90)PS      Turbo Intercooled      TD4610      1007

					
<b>TB307</b> 173x22	<b>TBK065</b> Component No: TB307; AE1061TP;AE1049GP		<b>KIT</b>		

		
B x C x D	OE	MAT.
<b>V91291</b> 	7 547 158	 MD cr
37.50 x 8.00 x 116.50		45°
<b>V91321</b> 	7 588 577	 MD cr
33.50 x 8.00 x 116.45		45°
<b>V91392</b> 	5 990 533	 MD cr
33.50 x 8.00 x 116.70		45°
		<b>VAG92366</b>  46.50 x 8.00 x 14.10



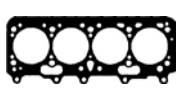





							
<b>BR680</b> Graphite Composite, 1.650mm	<b>DV680</b> 	<b>GV680</b> 	<b>HBS095</b> 	<b>JC738</b>	<b>JN459</b>		<b>NA5187</b>
<b>BR700</b> Graphite Composite, 1.950mm, 2 Notches			M12x1.25x133.00mm (x10)				30.00x52.00x7.00mm ACM

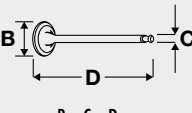
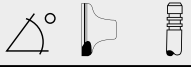
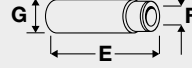











BR680, BR700

## 317 82.60 Diesel

160 D100      4 Cyl.      20:1      1929cc      51kW (69)PS      TD10307      1008

		
B x C x D	OE	MAT.
<b>V91291</b> 	7 547 158	 MD cr
37.50 x 8.00 x 116.50		45°
<b>V91321</b> 	7 588 577	 MD cr
33.50 x 8.00 x 116.45		45°
<b>V91392</b> 	5 990 533	 MD cr
33.50 x 8.00 x 116.70		45°
		<b>VAG92366</b>  46.50 x 8.00 x 14.10

							
<b>BV680</b> Fibre Composite, 1.670mm, 0 Notches	<b>DV680</b> 	<b>GV680</b> 	<b>HBS095</b> 	<b>JC738</b>	<b>JN459</b>		
<b>BV690</b> Fibre Composite, 1.750mm, 1 Notch			M12x1.25x133.00mm (x10)				
<b>BV700</b> Fibre Composite, 1.850mm, 2 Notches							



BV680, BV690, BV700

<b>318</b>	<b>82.60</b>	<b>Diesel</b>	
<b>230 A2.000</b>	4 Cyl.	20:1	1929cc
			<b>51kW (70)PS</b>
			<b>TD862 1009</b>

<b>TB278</b> 173x25.4 →08/98					

B x C x D	OE	MAT.	45°	H	E x F x G
<b>V91295</b> ■	5 990 532		45°	H	<b>VAG92366</b> ■ ■
37.50 x 8.00 x 117.00		MB cr			46.50 x 8.00 x 14.10
<b>V91767</b> ■	5 990 532		45°	H	
37.50 x 8.00 x 117.00		MB cr			
<b>V91392</b> ■	5 990 533		45°		
33.50 x 8.00 x 116.70		MD cr			

<b>BR680</b> Graphite Composite, 1.650mm <b>AC5140</b> MLS, 1.660mm <b>BV680</b> Fibre Composite, 1.670mm, 0 Notches <b>BV690</b> Fibre Composite, 1.750mm, 1 Notch <b>AC5150</b> MLS, 1.760mm <b>BV700</b> Fibre Composite, 1.850mm, 2 Notches <b>AC5180</b> MLS, 1.860mm <b>BR700</b> Graphite Composite, 1.950mm, 2 Notches <b>AC5160</b> MLS, 1.960mm	<b>DV680</b> ▲	<b>GV680</b> ▲	<b>HBS095</b> ⊗ M12x1.25x133.00mm (x10)	<b>JC738</b>	<b>JN459</b>	<b>HR363</b> ■	<b>NA5187</b> 30.00x52.00x7.00mm ACM
AC5140, AC5150, AC5180, AC5160	BR680, BR700	BV680, BV690, BV700					

## 319

## 82.60

## Diesel



230 A3.000	4 Cyl.	20:1	1929cc	60kW (82)PS	Turbocharged	TD5481	1010
230 A4.000 Euro 2	4 Cyl.	19:1	1929cc	59kW (80)PS	Turbocharged	TD4407	1010

<b>TB278</b> 173x25.4 →08/98					
[6] Mechanical		[6] Mécanique		[6] Meccanico	

[6] Mechanical [6] Mécanique [6] Meccanico [6] Mecánico

<b>V91295</b> ■ 37.50 x 8.00 x 117.00	5 990 532	 MAT. MB cr	45°	H	<b>VAG92366</b> ■ ■ ■ 46.50 x 8.00 x 14.10
<b>V91767</b> ■ 37.50 x 8.00 x 117.00	5 990 532	 MB cr	45°	H	
<b>V91392</b> ■ 33.50 x 8.00 x 116.70	5 990 533	 MD cr	45°		

<b>BR680</b> Graphite Composite, 1.650mm	<b>DV680</b> ▲	<b>GV680</b> ▲	<b>HBS095</b> ☒ M12x1.25x133.00mm (x10)	<b>JC738</b>	<b>JN459</b>	<b>HR363</b> ■	<b>NA5187</b> 30.00x52.00x7.00mm ACM
<b>AC5140</b> MLS, 1.660mm							
<b>BV680</b> Fibre Composite, 1.670mm, 0 Notches							
<b>BV690</b> Fibre Composite, 1.750mm, 1 Notch							
<b>AC5150</b> MLS, 1.760mm							
<b>BV700</b> Fibre Composite, 1.850mm, 2 Notches							
<b>AC5180</b> MLS, 1.860mm							
<b>BW980</b> Fibre Composite, 1.930mm, 3 Notches							
<b>AC5160</b> MLS, 1.960mm							

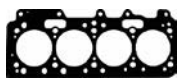

AC5140, AC5150, AC5180, AC5160











BR680











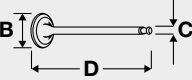



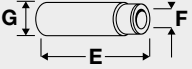



BV680, BV690, BV700, BW980



<b>320</b>	 <b>82.60</b>	<b>Diesel</b>					
<b>280 A1.000</b>	4 Cyl.	20:1	1929cc	<b>60kW (82)PS</b>	<b>Turbocharged</b>	<b>TD1043</b>	<b>1010</b>

					
<b>TB278</b> 173x25.4					<b>FOL104 (x8) [6]</b>
[6] Mechanical	[6] Mécanique	[6] Meccanico	[6] Mecánico		

					
B x C x D	OE	MAT.	45°	H	E x F x G
<b>V91295</b> ■	5 990 532	 MB cr	45°	H	<b>VAG92366</b> ■ ■ ■ 46.50 x 8.00 x 14.10
37.50 x 8.00 x 117.00					
<b>V91767</b> ■	5 990 532	 MB cr	45°	H	
37.50 x 8.00 x 117.00					
<b>V91392</b> ■	5 990 533	 MD cr	45°		
33.50 x 8.00 x 116.70					

							
<b>BR680</b> Graphite Composite, 1.650mm	<b>DV680</b> ▲	<b>GV680</b> ▲	<b>HBS095</b> ⊕ M12x1.25x133.00mm (x10)	<b>JC738</b>	<b>JN459</b>	<b>HR596</b> ■	<b>NA5187</b> 30.00x52.00x7.00mm ACM
<b>BV680</b> Fibre Composite, 1.670mm, 0 Notches							
<b>BV690</b> Fibre Composite, 1.750mm, 1 Notch							
<b>BV700</b> Fibre Composite, 1.850mm, 2 Notches							
<b>BW980</b> Fibre Composite, 1.930mm, 3 Notches							
<b>BR700</b> Graphite Composite, 1.950mm, 2 Notches							



BR680, BR700



BV680, BV690, BV700, BW980

## 321

### 82.60

### Diesel



831 D1.000

4 Cyl.

20:1

1929cc

48-59kW (55-80)PS

Turbo Intercooled

TD4607

1011

<b>TB351</b> 126x25.4					<b>FOL104 (x8) [6]</b>
<b>TB352</b> 57x19					
Driven unit: injection pump					
[6] Mechanical	[6] Mécanique	[6] Meccanico	[6] Mecánico		

B x C x D	OE	MAT.	45°	45°	E x F x G
<b>V91291</b> ■	7 547 158		45°		<b>VAG92366</b> ■ ■
37.50 x 8.00 x 116.50		MD cr			46.50 x 8.00 x 14.10
<b>V91321</b> ■	7 588 577		45°		
33.50 x 8.00 x 116.45		MD cr			
Eng. → 674284					
<b>V91392</b> ■	5 990 533		45°		
33.50 x 8.00 x 116.70		MD cr			
Eng. 674285 →					

<b>BR680</b> Graphite Composite, 1.650mm	<b>DT290</b> ▲	<b>GV680</b> ▲	<b>HBS095</b> ☒	<b>JC738</b>	<b>JN568</b>	<b>HR596</b> ■	<b>NA5187</b>
<b>BR700</b> Graphite Composite, 1.950mm, 2 Notches			M12x1.25x133.00mm (x10)				30.00x52.00x7.00mm ACM

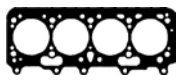

BR680, BR700

<b>322</b>	<b>82.60</b>	<b>Diesel</b>				
<b>831 D1.000</b>	4 Cyl.	1929cc	59kW (80)PS	Turbocharged	<b>TD4410</b>	<b>1012</b>

<b>TB351</b> 126x25.4	<b>TB352</b> 57x19	Driven unit: injection pump			

<b>B x C x D</b>	<b>E x F x G</b>				
<b>OE</b>	<b>MAT.</b>				
<b>V91291</b>	7 547 158		45°	<b>VAG92366</b>	
37.50 x 8.00 x 116.50		MD cr		46.50 x 8.00 x 14.10	
<b>V91321</b>	7 588 577		45°		
33.50 x 8.00 x 116.45		MD cr			
<b>V91392</b>	5 990 533		45°		
33.50 x 8.00 x 116.70		MD cr			

<b>BR680</b> Graphite Composite, 1.650mm	<b>DT290</b> ▲	<b>GV680</b> ▲	<b>HBS095</b> ⊗	<b>JC738</b>	<b>JN568</b>	<b>HR596</b> ■	<b>NA5187</b>
<b>BV680</b> Fibre Composite, 1.670mm, 0 Notches			M12x1.25x133.00mm (x10)				30.00x52.00x7.00mm ACM
<b>BR700</b> Graphite Composite, 1.950mm, 2 Notches							



BR680, BR700



BV680

## 323

## 82.60

## Diesel



835 A4.000

4 Cyl.

19.9:1

1929cc

66kW (90)PS

Turbocharged

TD1846

1013

<b>TB307</b> 173x22	<b>TBK065</b> Component No: TB307; AE1061TP;AE1049GP		<b>KIT</b>		<b>FOL104 (x8) [6]</b>

[6] Mechanical

[6] Mécanique

[6] Meccanico

[6] Mecánico

B x C x D	OE	MAT.	45°		E x F x G
<b>V91291</b> ■ 37.50 x 8.00 x 116.50	7 547 158	 MD cr	45°		<b>VAG92366</b> ■ ■ ■ 46.50 x 8.00 x 14.10
<b>V91321</b> ■ 33.50 x 8.00 x 116.45 Eng.→674284	7 588 577	 MD cr	45°		
<b>V91392</b> ■ 33.50 x 8.00 x 116.70 Eng.674285→	5 990 533	 MD cr	45°		

<b>BR680</b> Graphite Composite, 1.650mm <b>BR700</b> Graphite Composite, 1.950mm, 2 Notches	<b>DV680</b> ▲	<b>GV680</b> ▲	<b>HBS095</b> ☒ M12x1.25x133.00mm (x10)	<b>JC738</b>	<b>JN459</b>		<b>NA5187</b> 30.00x52.00x7.00mm ACM



BR680, BR700

<b>324</b>	<b>82.60</b>	<b>Diesel</b>					
<b>835 A4.046</b>	4 Cyl.	20:1	1929cc	<b>66kW (90)PS</b>	<b>Turbocharged</b>	<b>TD5425</b>	<b>1013</b>

<b>TB307</b> 173x22	<b>TBK065</b> Component No: TB307; AE1061TP;AE1049GP		<b>KIT</b>		

<b>B x C x D</b>	<b>E x F x G</b>
<b>OE</b>	
<b>MAT.</b>	
<b>V91291</b>	<b>VAG92366</b>
37.50 x 8.00 x 116.50	46.50 x 8.00 x 14.10
<b>V91321</b>	
33.50 x 8.00 x 116.45	
Eng. → 674284	
<b>V91392</b>	
33.50 x 8.00 x 116.70	
Eng. 674285 →	

<b>BR680</b> Graphite Composite, 1.650mm <b>BR700</b> Graphite Composite, 1.950mm, 2 Notches	<b>DV680</b> ▲	<b>GV680</b> ▲	<b>HBS095</b> ☒ M12x1.25x133.00mm (x10)	<b>JC738</b>	<b>JN459</b>		<b>NA5187</b> 30.00x52.00x7.00mm ACM



BR680, BR700

## 325

## 82.60

## Diesel



AR 33601      4 Cyl.      19.2:1      1929cc      66-68kW (90-92)PS      Turbo Intercooled      TD5069      1014

<b>TB307</b> 173x22	<b>TBK065</b> Component No: TB307; AE1061TP;AE1049GP		<b>KIT</b>		

B x C x D	E x F x G
<b>V91291</b> ■ 37.50 x 8.00 x 116.50	<b>VAG96203</b> ■ ■ ■ 43.00 x 8.03 x 14.08
<b>V91321</b> ■ 33.50 x 8.00 x 116.45	<b>VAG96210</b> ■ ■ ■ 43.00 x 8.04 x 14.04

<b>BR680</b> Graphite Composite, 1.650mm <b>AC5140</b> MLS, 1.660mm <b>BV680</b> Fibre Composite, 1.670mm, 0 Notches <b>BV690</b> Fibre Composite, 1.750mm, 1 Notch <b>AC5150</b> MLS, 1.760mm <b>BV700</b> Fibre Composite, 1.850mm, 2 Notches <b>AC5180</b> MLS, 1.860mm <b>BW980</b> Fibre Composite, 1.930mm, 3 Notches <b>AC5160</b> MLS, 1.960mm	<b>DV680</b> ▲	<b>GV680</b> ▲	<b>HBS095</b> ☉ M12x1.25x133.00mm (x10)	<b>JC738</b>	<b>JN459</b>	<b>HR596</b> ■	<b>NA5187</b> 30.00x52.00x7.00mm ACM

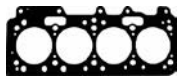

AC5140, AC5150, AC5180, AC5160









BR680











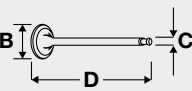
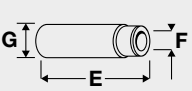



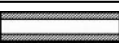

BV680, BV690, BV700, BW980

**326**  **82.60** **Diesel** 

AR 67501 4 Cyl. 19.2:1 1929cc 66-68kW (90-92)PS Turbocharged TD140 1014

					
<b>TB307</b> 173x22	<b>TBK065</b> Component No: TB307; AE1061TP;AE1049GP		<b>KIT</b>		









	
B x C x D	E x F x G
OE	
MAT.	
	
<b>V91291</b> 	<b>VAG96203</b> 
37.50 x 8.00 x 116.50	43.00 x 8.03 x 14.08
<b>V91321</b> 	<b>VAG96210</b> 
33.50 x 8.00 x 116.45	43.00 x 8.04 x 14.04

							
<b>AC5140</b> MLS, 1.660mm <b>BV680</b> Fibre Composite, 1.670mm, 0 Notches <b>BV690</b> Fibre Composite, 1.750mm, 1 Notch <b>AC5150</b> MLS, 1.760mm <b>BV700</b> Fibre Composite, 1.850mm, 2 Notches <b>AC5180</b> MLS, 1.860mm <b>BW980</b> Fibre Composite, 1.930mm, 3 Notches <b>AC5160</b> MLS, 1.960mm	<b>DV680</b> ▲	<b>GV680</b> ▲	<b>HBS095</b> ☉ M12x1.25x133.00mm (x10)	<b>JC738</b>	<b>JN459</b>	<b>HR363</b> ☒	<b>NA5187</b> 30.00x52.00x7.00mm ACM









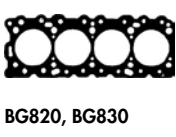

**327**  **83.00** **Diesel** 









138 A5.000 4 Cyl. 20:1 1714cc 40-43kW (55-58)PS TD4358 1016

							
<b>BG820</b> Fibre Composite, 1.800mm, 1 Notch <b>BG830</b> Fibre Composite, 1.950mm, 2 Notches	<b>DG811</b> ▲						



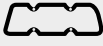

# FIAT GROUP













<b>328</b>	 <b>83.00</b>	<b>Diesel</b>				
<b>138 B6.000</b>	4 Cyl.	20.5:1	1714cc	<b>43kW (58)PS</b>	<b>TD922</b>	<b>1018</b>
						
<b>TB150</b> 138x25.4 03/83 → 04/85					<b>FOL104 (x8) [6]</b>	
[6] Mechanical	[6] Mécanique	[6] Meccanico	[6] Mecánico			

							
<b>BG820</b> Fibre Composite, 1.800mm, 1 Notch <b>BG830</b> Fibre Composite, 1.950mm, 2 Notches	<b>DG811 ▲</b>					<b>HR596</b> 	<b>NA5187</b> 30.00x52.00x7.00mm ACM





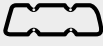





BG820, BG830







<b>329</b>	 <b>83.00</b>	<b>Petrol</b>					
<b>939 B1.000</b>	4 Cyl.	9.5:1	1742cc	<b>147kW (200)PS</b>	<b>Turbocharged</b>	<b>TD22716</b>	<b>1019</b>
<b>939 B1.000</b>	4 Cyl.	9.5:1	1742cc	<b>147kW (200)PS</b>	<b>Turbocharged</b>	<b>TD24691</b>	<b>1019</b>
<b>940 A1.000</b>	4 Cyl.	9.25:1	1742cc	<b>173-177kW (235-241)PS</b>	<b>Turbo Intercooled</b>	<b>TD23922</b>	<b>1020</b>



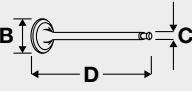
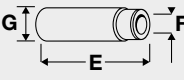



							
						<b>FOL187 (x16)</b>	
							
							<b>NA5058</b> 40.00x55.00x7.00mm FPM



<b>330</b>	 <b>83.00</b>	<b>Petrol</b>	
<b>LFW</b>	4 Cyl.	9.5:1	1761cc
			<b>73kW (99)PS</b>
			<b>TD10167 1021</b>

					
<b>TB419</b> 114x17 →12/00, HNBR	<b>TBK010</b> →12/00 Component No: TB419; AE1026TP				
<b>TB346</b> 114x17 →12/00 Polychloroprene (Neoprene)					

	
B x C x D	E x F x G
OE	
MAT.	
	
45° Y H	<b>VAG92332B</b> ■ 38.70 x 8.02 x 13.07
	
45°	<b>VAG96056B</b> ■ 45.00 x 8.03 x 13.07
	
	<b>VAG96116B</b> ■ 45.00 x 8.03 x 13.58

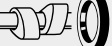
							
<b>BL650</b> Fibre Composite, 1.200mm <b>BR510</b> Fibre Composite, 1.440mm	<b>CY131</b> ▲		<b>HBS260</b> ⊕ M11x1.50x168.00mm (x10) Eng.07448 →	<b>JD519</b> ■ <b>JC415</b> ■	<b>JN547</b>		<b>NF817</b> 36.00x50.00x7.00mm FPM



BL650

# FIAT GROUP

## 331



83.00

Diesel



D8B 4 Cyl. 1905cc 68kW (92)PS Turbocharged TD6828 1022

<b>TB560</b> 136x25.4 →08/00, HNBR	<b>TBK020</b> →08/00 Component No: TB175; AE1080TP;AE1081GP		<b>KIT</b>		<b>FOL73</b> (x8) [6] <b>FOL150</b> (x8) [6]

[6] Mechanical [6] Mécanique [6] Meccanico [6] Mecánico

<b>B x C x D</b>	<b>E x F x G</b>
<b>V91144</b> ■ 38.50 x 8.00 x 112.50	<b>VAG92288B</b> ■ ■ ■ 52.00 x 8.03 x 14.28
<b>V91145</b> ■ 33.00 x 8.00 x 112.00	<b>VAG92465B</b> ■ ■ ■ 52.00 x 8.03 x 14.07
<b>V94017</b> ■ 33.00 x 8.00 x 111.90	

<b>BX930</b> Steel Elastomer, 1.360mm, 1 Notch <b>BX940</b> Steel Elastomer, 1.400mm, 2 Notches <b>BX950</b> Steel Elastomer, 1.440mm, 3 Notches <b>BX960</b> Steel Elastomer, 1.480mm, 4 Notches <b>BX970</b> Steel Elastomer, 1.520mm, 5 Notches <b>BX980</b> Steel Elastomer, 1.590mm ⊖(0.83) mm →	<b>DJ720</b> ▲	<b>GJ720</b> ▲	<b>HBS277</b> ⊕ M12x1.50x148.00mm (x10)	<b>JC759</b> (Steel) <b>JC423</b> ■	<b>JN544</b>	<b>HR569</b> ■	<b>NF841</b> 35.00x50.00x8.00mm FPM



BX930, BX940, BX950, BX960, BX970, BX980

## 332



83.00

Diesel



D8B (XUD9TE) 4 Cyl. 21.8:1 1905cc 66-69kW (90-94)PS Turbo Intercooled TD21263 1023

<b>BX930</b> Steel Elastomer, 1.360mm, 1 Notch <b>BX940</b> Steel Elastomer, 1.400mm, 2 Notches <b>BX950</b> Steel Elastomer, 1.440mm, 3 Notches <b>BX960</b> Steel Elastomer, 1.480mm, 4 Notches <b>BX970</b> Steel Elastomer, 1.520mm, 5 Notches <b>BX980</b> Steel Elastomer, 1.590mm ⊖(0.83) mm →		<b>GJ720</b> ▲	<b>HBS277</b> ⊕ M12x1.50x148.00mm (x10)	<b>JN544</b>	<b>NF841</b> 35.00x50.00x8.00mm FPM



BX930, BX940, BX950, BX960, BX970, BX980

<b>333</b>	<b>83.00</b>	<b>Diesel</b>	
<b>D9B</b>	4 Cyl.	1905cc	50-51kW (68-69)PS
			<b>TD6827 1024</b>

<b>TB560</b> 136x25.4 HNBR <b>TB175</b> 136x25.4 Polychloroprene (Neoprene)	<b>TBK020</b> Component No: TB175; AE1080TP;AE1081GP	<b>CAM373</b> [7] <b>CAM354</b> [8]	<b>CKS2373</b>	<b>FOL150</b> (x8) [6]
[6] Mechanical [7] Camshaft driven vacuum pump. [8] Pulley driven vacuum pump.	[6] Mécanique [7] Pompe à vide entraînée par l'arbre à cames [8] Pompe à vide entraînée par poulie	[6] Meccanico [7] Pompa vacuum azionata dall'albero a camme [8] Pompa vacuum azionata dalla puleggia	[6] Mecánico [7] Bomba de vacío accionada por el árbol de levas [8] Bomba de vacío accionada por polea	

<b>V91144</b> ■ 38.50 x 8.00 x 112.50	<b>V94154</b> ■ 38.50 x 8.00 x 112.40	<b>V91145</b> ■ 33.00 x 8.00 x 112.00	<b>V94024</b> ■ 33.00 x 8.00 x 112.00	<b>VAG92288B</b> ■ ■ ■ 52.00 x 8.03 x 14.28	<b>VAG92331B</b> ■ ■ ■ 50.00 x 8.03 x 14.08	<b>VAG96160B</b> ■ ■ ■ 48.00 x 8.02 x 14.09
B x C x D	OE	MAT.	45°	H	E x F x G	
	96 005 391	MB	45°	H		
	0948.94	MB	45°	H		
	96 137 360	MD cr	45°			
	0949.64	MD	45°			

<b>BX880</b> Fibre Composite, 1.360mm, 1 Notch →(0.56)→(0.67) mm	<b>DJ720</b> ▲	<b>GJ720</b> ▲	<b>HBS084</b> ⊕ M12x1.50x120.00mm (x10)	<b>JD5972</b> ■ <b>JC423</b> ■	<b>JN544</b>	<b>HR569</b> ■	<b>NF841</b> 35.00x50.00x8.00mm FPM
<b>BX890</b> Fibre Composite, 1.400mm, 2 Notches →(0.68)→(0.71) mm							
<b>BX900</b> Fibre Composite, 1.440mm, 3 Notches →(0.72)→(0.75) mm							
<b>BX910</b> Fibre Composite, 1.480mm, 4 Notches →(0.76)→(0.79) mm							
<b>BX920</b> Fibre Composite, 1.520mm, 5 Notches →(0.8)→(0.83) mm							



**BX880, BX890, BX900, BX910, BX920**

# FIAT GROUP

## 334

83.00

**Diesel**



**D9B (XUD9A)**

4 Cyl.

23:1

1905cc

47-52kW (64-71)PS

**TD21265**

**1025**

<b>TB560</b> 136x25.4 →11/01, HNBR	<b>TBK020</b> →11/01 Component No: TB175; AE1080TP;AE1081GP		<b>KIT</b>		<b>FOL150 (x8) [6]</b>

[6] Mechanical

[6] Mécanique

[6] Meccanico

[6] Mecánico

<b>B x C x D</b>	<b>E x F x G</b>
<b>V91144</b>	<b>VAG92288B</b>
38.50 x 8.00 x 112.50	52.00 x 8.03 x 14.28
<b>V94154</b>	<b>VAG92331B</b>
38.50 x 8.00 x 112.40	50.00 x 8.03 x 14.08
<b>V91145</b>	<b>VAG96160B</b>
33.00 x 8.00 x 112.00	48.00 x 8.02 x 14.09
<b>V94024</b>	
33.00 x 8.00 x 112.00	

<b>BX880</b> Fibre Composite, 1.360mm, 1 Notch →(0.56)→(0.67) mm	<b>DJ720</b> ▲	<b>GJ720</b> ▲	<b>HBS084</b> M12x1.50x120.00mm (x10)	<b>JD5972</b> <b>JC423</b>	<b>JN544</b>	<b>HR569</b>	<b>NF841</b> 35.00x50.00x8.00mm FPM
<b>BX890</b> Fibre Composite, 1.400mm, 2 Notches →(0.68)→(0.71) mm							
<b>BX900</b> Fibre Composite, 1.440mm, 3 Notches →(0.72)→(0.75) mm							
<b>BX910</b> Fibre Composite, 1.480mm, 4 Notches →(0.76)→(0.79) mm							
<b>BX920</b> Fibre Composite, 1.520mm, 5 Notches →(0.8)→(0.83) mm							



**BX880, BX890, BX900, BX910, BX920**

## 335

83.00

**Diesel**



**DHX (XUD9TE)**

4 Cyl.

21.8:1

1905cc

66-69kW (90-94)PS

**Turbo Intercooled**

**TD21264**

**1023**

<b>BX930</b> Steel Elastomer, 1.360mm, 1 Notch	<b>DJ720</b> ▲	<b>GJ720</b> ▲	<b>HBS277</b> M12x1.50x148.00mm (x10)				<b>NF841</b> 35.00x50.00x8.00mm FPM
<b>BX940</b> Steel Elastomer, 1.400mm, 2 Notches							
<b>BX950</b> Steel Elastomer, 1.440mm, 3 Notches							
<b>BX960</b> Steel Elastomer, 1.480mm, 4 Notches							
<b>BX970</b> Steel Elastomer, 1.520mm, 5 Notches							
<b>BX980</b> Steel Elastomer, 1.590mm →(0.83) mm→							



**BX930, BX940, BX950, BX960, BX970, BX980**

<b>336</b>	<b>83.00</b>	<b>Diesel</b>						
<b>DHX (XUD9TF/L)</b>	4 Cyl.	21.8:1	1905cc	<b>66-68kW (90-92)PS</b>	<b>Turbo Intercooled</b>	<b>TD4352</b>	<b>1026</b>	

<b>TB560</b> 136x25.4 →11/01, HNBR	<b>TBK020</b> →11/01 Component No: TB175; AE1080TP;AE1081GP				<b>FOL150 (x8) [6]</b>

[6] Mechanical      [6] Mécanique      [6] Meccanico      [6] Mecánico

<b>B x C x D</b>	<b>OE</b>	<b>MAT.</b>	<b>45°</b>	<b>H</b>	<b>E x F x G</b>	
<b>V91144</b>	96 005 391		45°	H	<b>VAG92288B</b>	
38.50 x 8.00 x 112.50		MB			52.00 x 8.03 x 14.28	
<b>V91145</b>	96 137 360		45°		<b>VAG92465B</b>	
33.00 x 8.00 x 112.00		MD cr			52.00 x 8.03 x 14.07	
<b>V94017</b>	0949.74		45°			
33.00 x 8.00 x 111.90		MD cr				

<b>BX930</b> Steel Elasto, 1.360mm, 1 Notch <b>BX940</b> Steel Elasto, 1.400mm, 2 Notches <b>BX950</b> Steel Elasto, 1.440mm, 3 Notches <b>BX960</b> Steel Elasto, 1.480mm, 4 Notches <b>BX970</b> Steel Elasto, 1.520mm, 5 Notches <b>BX980</b> Steel Elasto, 1.590mm ⊖(0.83) mm →	<b>DJ720</b> →Eng.08574 <b>DS435</b>	<b>GS435</b> 10/83 →03/87	<b>HBS277</b> M12x1.50x148.00mm (x10) Eng.08575→	<b>JC759</b> (Steel) <b>JC991</b> <b>JC423</b>	<b>JN544</b>	<b>HR569</b>	<b>NF841</b> 35.00x50.00x8.00mm FPM



BX930, BX940, BX950, BX960, BX970, BX980

<b>337</b>	<b>83.00</b>	<b>Diesel</b>						
<b>DHX</b>	4 Cyl.	21.8:1	1905cc	<b>59kW (80)PS</b>	<b>Turbo Intercooled</b>	<b>TD24799</b>	<b>1027</b>	

					<b>FOL150 (x8) [6]</b>

[6] Mechanical      [6] Mécanique      [6] Meccanico      [6] Mecánico

<b>BX930</b> Steel Elasto, 1.360mm, 1 Notch <b>BX940</b> Steel Elasto, 1.400mm, 2 Notches <b>BX950</b> Steel Elasto, 1.440mm, 3 Notches <b>BX960</b> Steel Elasto, 1.480mm, 4 Notches <b>BX970</b> Steel Elasto, 1.520mm, 5 Notches <b>BX980</b> Steel Elasto, 1.590mm ⊖(0.83) mm →							<b>NF841</b> 35.00x50.00x8.00mm FPM



BX930, BX940, BX950, BX960, BX970, BX980

## 338

83.00

**Diesel**



DJY (XUD9)

4 Cyl.

23.5:1

1905cc

50-52kW (68-71)PS

TD21267

1028

[6] Mechanical		[6] Mécanique		[6] Meccanico		[6] Mecánico	
				JC423			NF841 35.00x50.00x8.00mm FPM

## 339

83.00

**Diesel**



DJY

4 Cyl.

23.5:1

1905cc

50kW (68)PS

TD12748

1029



<b>TB560</b> 136x25.4 →11/01, HNBR	<b>TBK020</b> →11/01 Component No: TB175; AE1080TP;AE1081GP	<b>CAM373</b> [7] <b>CAM354</b> [8]	<b>CKS2373</b>				<b>FOL150</b> (x8) [6]
[6] Mechanical [7] Camshaft driven vacuum pump. [8] Pulley driven vacuum pump.		[6] Mécanique [7] Pompe à vide entraînée par l'arbre à cames [8] Pompe à vide entraînée par poulie		[6] Meccanico [7] Pompa vacuum azionata dall'albero a camme [8] Pompa vacuum azionata dalla puleggia		[6] Mecánico [7] Bomba de vacío accionada por el árbol de levas [8] Bomba de vacío accionada por polea	











B x C x D	E x F x G
<b>V91144</b>	<b>VAG92288B</b>
38.50 x 8.00 x 112.50	52.00 x 8.03 x 14.28
<b>V94154</b>	<b>VAG92331B</b>
38.50 x 8.00 x 112.40	50.00 x 8.03 x 14.08
<b>V91145</b>	<b>VAG96160B</b>
33.00 x 8.00 x 112.00	48.00 x 8.02 x 14.09
<b>V94024</b>	
33.00 x 8.00 x 112.00	

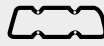

<b>BX880</b> Fibre Composite, 1.360mm, 1 Notch →(0.56)→(0.67) mm	<b>BX890</b> Fibre Composite, 1.400mm, 2 Notches →(0.68)→(0.71) mm	<b>BX900</b> Fibre Composite, 1.440mm, 3 Notches →(0.72)→(0.75) mm	<b>BX910</b> Fibre Composite, 1.480mm, 4 Notches →(0.76)→(0.79) mm	<b>BX920</b> Fibre Composite, 1.520mm, 5 Notches →(0.8)→(0.83) mm	DJ720	<b>GJ720</b>	<b>HBS084</b> M12x1.50x120.00mm (x10)	<b>JD5972</b> JC423	JN544	<b>HR569</b>	<b>NF841</b> 35.00x50.00x8.00mm FPM



















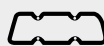

BX880, BX890, BX900, BX910, BX920

<b>340</b>	 <b>83.00</b>	<b>Diesel</b>					
198 A5.000	4 Cyl.	16.5:1	1956cc	121kW (165)PS	Turbo Intercooled	TD24647	1031
250 A1.000 Euro 5	4 Cyl.	16.5:1	1956cc	85kW (116)PS	Turbo Intercooled	TD25173	1032
939 B4.000	4 Cyl.		1956cc	100kW (136)PS	Turbo Intercooled	TD24644	1035
939 B5.000	4 Cyl.	16.5:1	1956cc	125kW (170)PS	Turbo Intercooled	TD24645	1035
939 B5.000	4 Cyl.		1956cc	100-125kW (140-170)PS	Turbo Intercooled	TD26620	1035
940 A5.000 Euro 5	4 Cyl.	16.5:1	1956cc	103kW (140)PS	Turbo Intercooled	TD24578	1035
940 A5.000 Euro 5	4 Cyl.	16.5:1	1956cc	103kW (140)PS	Turbo Intercooled	TD26672	1035
D20AA Euro 5	4 Cyl.	16.5:1	1956cc	99kW (135)PS	Turbocharged	TD24670	1032







							
AH7370 MLS, 0.95mm, 0 Holes							
AH7380 MLS, 1.05mm, 1 Hole							
AH7390 MLS, 1.15mm, 2 Holes							
							
AH7370	AH7380	AH7390					

<b>341</b>	 <b>83.00</b>	<b>Diesel</b>					
198 A5.000	4 Cyl.	16.1:1	1956cc	121kW (165)PS	Turbo Intercooled	TD21043	1030
198 A5.000	4 Cyl.	16.5:1	1956cc	121kW (165)PS	Turbocharged	TD24569	1030
198 A8.000	4 Cyl.	16.5:1	1956cc	121kW (165)PS	Turbo Intercooled	TD25650	1032
263 A1.000 Euro 5	4 Cyl.	16.5:1	1956cc	99kW (135)PS	Turbo Intercooled	TD24764	1032
939 B3.000	4 Cyl.		1956cc	125kW (170)PS	Turbo Intercooled	TD23107	1032
940 A4.000	4 Cyl.	16.5:1	1956cc	125kW (170)PS	Turbo Intercooled	TD23924	1030

						<b>FOL187</b> (x16)	
							
AH7370 MLS, 0.95mm, 0 Holes							
AH7380 MLS, 1.05mm, 1 Hole							
AH7390 MLS, 1.15mm, 2 Holes							
							
AH7370	AH7380	AH7390					

<b>342</b>	 <b>83.00</b>	<b>Diesel</b>					
844 A2.000	4 Cyl.	16.5:1	1956cc	120kW (163)PS	Turbocharged	TD24593	1034

						<b>FOL187</b> (x16)	

# FIAT GROUP

## 343



83.00

Petrol



932 A2.000

4 Cyl.

1970cc

119-121kW (162-165)PS

TD18076

1036



TB468  
168x24  
→03/07

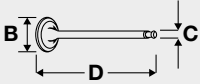

B x C x D

OE



MAT.

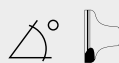

45°



H

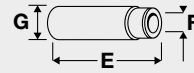

E x F x G

V91933 ■  
33.40 x 7.00 x 113.10

608 11 153

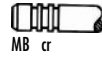

MB cr

V91934 ■  
28.00 x 7.00 x 108.60

608 11 154

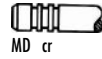

MD cr

V94591 ■  
28.00 x 7.00 x 108.80

606 74 496

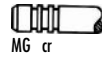

MG cr

VAG96123 ■  
42.25 x 7.02 x 13.05



VAG96230 ■  
46.00 x 7.02 x 13.06

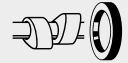
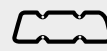

AD5870 MLS

JD273 ■  
MLS

NA5053

30.00x42.00x7.00mm FPM



AD5870

## 344



83.00

Petrol



937 A1.000

4 Cyl.

11.3:1

1970cc

119-122kW (162-166)PS

TD16381

1037



TB468  
168x24

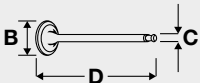

B x C x D

OE



MAT.

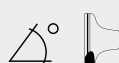

45°



H

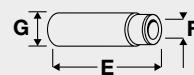

E x F x G

V91933 ■  
33.40 x 7.00 x 113.10

608 11 153

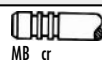

MB cr

V91934 ■  
28.00 x 7.00 x 108.60

608 11 154

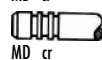

MD cr

V94591 ■  
28.00 x 7.00 x 108.80

606 74 496

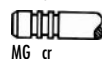

MG cr

VAG96123 ■  
42.25 x 7.02 x 13.05



VAG96230 ■  
46.00 x 7.02 x 13.06

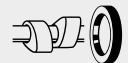
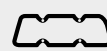

AD5870 MLS

HBS132 ☒  
M10x1.25x254.00mm (x10)

JD273 ■  
MLS

NA5053

30.00x42.00x7.00mm FPM



AD5870



## 345

**83.00**
**Petrol**

**AR 16201**







4 Cyl.



10:1





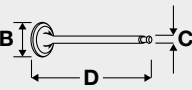
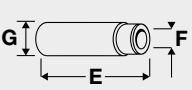

1970cc

110kW (150)PS

**TD4188**
**1038**

					
<b>TB468</b> 168x24 <b>TB607</b> 126x15 Eng.→0134318 Driven unit: balance shaft				<b>FOL106</b> (x16) Height: 24mm <b>FOL145</b> (x16) Height: 26mm	

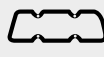
			
B x C x D	OE	E x F x G	
<b>V91933</b> ■	608 11 153	<b>VAG96123</b> ■	
33.40 x 7.00 x 113.10		42.25 x 7.02 x 13.05	
<b>V91934</b> ■	608 11 154	<b>VAG96230</b> ■	
28.00 x 7.00 x 108.60		46.00 x 7.02 x 13.06	
<b>V94591</b> ■	606 74 496		
28.00 x 7.00 x 108.80			

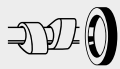
							
<b>AA5420</b> MLS, 0.380mm <b>AD5950</b> MLS, 0.450mm	<b>DW710</b>	<b>GW713</b>		<b>JD271</b> ■ (Metal) <b>JD273</b> ■ MLS	<b>HL700</b> ■	<b>HR599</b> ■	<b>NA5053</b> 30.00x42.00x7.00mm FPM

**AA5420**

**AD5950**

# FIAT GROUP

## 346

83.00

Petrol



AR 32301      4 Cyl.      10.1:1      1970cc      114kW (155)PS      TD9463      1038

<b>TB468</b> 168x24 <b>TB607</b> 126x15 Eng.→0134318 Driven unit: balance shaft	<b>TBK356</b> Component No: TB468; AE1147TP;AE1042TP				<b>FOL106</b> (x16) Height: 24mm <b>FOL145</b> (x16) Height: 26mm

B x C x D	E x F x G
OE	
MAT.	
<b>V91933</b> ■ 33.40 x 7.00 x 113.10	<b>VAG96123</b> ■ 42.25 x 7.02 x 13.05
<b>V91934</b> ■ 28.00 x 7.00 x 108.60	<b>VAG96230</b> ■ 46.00 x 7.02 x 13.06
<b>V94591</b> ■ 28.00 x 7.00 x 108.80	
608 11 153 MB cr 45° H	
608 11 154 MD cr 45° ss	
606 74 496 MG cr 45° ss H	

<b>BW710</b> Fibre Composite, 1.650mm	<b>DW711</b> →05/98 <b>DW712</b> 05/98→	<b>GW711</b> →05/98 <b>GW712</b> 05/98→	<b>HBS132</b> ☒ M10x1.25x254.00mm (x10)	<b>JD271</b> ■ (Metal) <b>JD273</b> ■ MLS	<b>JM5002</b> (Elastomer) 05/98→ <b>HL700</b> ■ →05/98	<b>HR599</b> ■	<b>NA5053</b> 30.00x42.00x7.00mm FPM



BW710

## 347

83.00

Petrol



AR 32303      4 Cyl.      10.1:1      1970cc      110-118kW (150-160)PS      TD19055      1039

					<b>FOL106</b> (x16) Height: 24mm <b>FOL145</b> (x16) Height: 26mm

<b>BW710</b> Fibre Composite, 1.650mm	<b>DW712</b>	<b>GW712</b>		<b>JD271</b> ■ (Metal) <b>JD273</b> ■ MLS	<b>JM5002</b> (Elastomer)	<b>HR599</b> ■	<b>NA5053</b> 30.00x42.00x7.00mm FPM



BW710

<b>348</b>	<b>83.00</b>	<b>Petrol</b>	
<b>AR 32310 D4</b>	4 Cyl.	10:1	1970cc
			<b>110kW (150)PS</b>
			<b>TD15391 1040</b>

<b>TB468</b> 168x24	<b>TBK356</b> Component No: TB468; AE1147TP;AE1042TP				<b>FOL106</b> (x16) Height: 24mm <b>FOL145</b> (x16) Height: 26mm
<b>TB732</b> 130x15					
Driven unit: balance shaft					

B x C x D	E x F x G
OE	
MAT.	
<b>V91933</b> ■ 33.40 x 7.00 x 113.10	<b>VAG96123</b> ■ 42.25 x 7.02 x 13.05
<b>V91934</b> ■ 28.00 x 7.00 x 108.60	<b>VAG96230</b> ■ 46.00 x 7.02 x 13.06
<b>V94591</b> ■ 28.00 x 7.00 x 108.80	

<b>AD5950</b> MLS, 0.450mm →05/00	<b>CA5420</b>		<b>HBS132</b> ☒ M10x1.25x254.00mm (x10)	<b>JD271</b> ■ (Metal)	<b>JM5002</b> (Elastomer)	<b>HR599</b> ■	<b>NA5053</b> 30.00x42.00x7.00mm FPM
<b>AA5420</b> MLS, 0.380mm 06/00→				<b>JD273</b> ■ MLS			



AA5420



AD5950

## 349



83.00

Petrol



AR 34103

4 Cyl.

10:1

1970cc

114kW (155)PS

TD11599

1038

<b>TB468</b> 168x24 →06/00	<b>TBK356</b> →06/00 Component No: TB468; AE1147TP;AE1042TP		<b>KIT</b>		<b>FOL106</b> (x16) Height: 24mm <b>FOL145</b> (x16) Height: 26mm







B x C x D	E x F x G
<b>V91933</b> ■ 33.40 x 7.00 x 113.10	<b>VAG96123</b> ■ 42.25 x 7.02 x 13.05
<b>V91934</b> ■ 28.00 x 7.00 x 108.60	<b>VAG96230</b> ■ 46.00 x 7.02 x 13.06
<b>V94591</b> ■ 28.00 x 7.00 x 108.80	
OE	
MAT.	
MB cr	45° H
MD cr	45° ss
MG cr	45° ss H

<b>BW710</b> Fibre Composite, 1.650mm	<b>DW712</b>	<b>GW712</b>	<b>HBS132</b> ☒ M10x1.25x254.00mm (x10)	<b>JD271</b> ■ (Metal) <b>JD273</b> ■ MLS	<b>JM5002</b> (Elastomer) <b>HL700</b> ■	<b>HR599</b> ■	<b>NA5053</b> 30.00x42.00x7.00mm FPM <b>NA5163</b> 32.00x47.00x10.00mm FPM







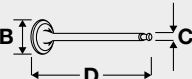
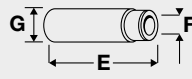
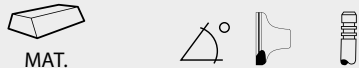

BW710

<b>350</b>	 <b>83.00</b>	<b>Petrol</b>	
<b>AR 36301 D4</b>	4 Cyl.	1970cc	<b>110kW (150)PS</b>
			<b>TD15392 1040</b>

					
<b>TB468</b> 168x24 →09/07	<b>TBK356</b> →09/07 Component No: TB468; AE1147TP;AE1042TP		<b>KIT</b>		<b>FOL106</b> (x16) Height: 24mm <b>FOL145</b> (x16) Height: 26mm

	
B x C x D	E x F x G
OE	
MAT.	
	
<b>V91933</b> ■ 33.40 x 7.00 x 113.10	<b>VAG96123</b> ■ 42.25 x 7.02 x 13.05
<b>V91934</b> ■ 28.00 x 7.00 x 108.60	<b>VAG96230</b> ■ 46.00 x 7.02 x 13.06
<b>V94591</b> ■ 28.00 x 7.00 x 108.80	
608 11 153 MB cr	45° H
608 11 154 MD cr	45° ss
606 74 496 MG cr	45° ss H

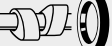
							
<b>AA5420</b> MLS, 0.380mm 06/00 →	<b>CA5420</b> 06/00 →	<b>HBS132</b> Ⓢ M10x1.25x254.00mm (x10)		<b>JM5002</b> (Elastomer) 05/98 →	<b>HR599</b> ■	<b>NA5053</b> 30.00x42.00x7.00mm FPM	



AA5420

# FIAT GROUP

## 351



83.00

Petrol



AR 67204      4 Cyl.      1970cc      110kW (150)PS      TD4190      1038

<b>TB468</b> 168x24 →09/99 <b>TB607</b> 126x15 Eng.→0117877 Driven unit: balance shaft	<b>TBK356</b> →09/99 Component No: TB468; AE1147TP;AE1042TP				<b>FOL106</b> (x16) Height: 24mm <b>FOL145</b> (x16) Height: 26mm

	OE	MAT.			
<b>V91933</b> ■ 33.40 x 7.00 x 113.10	608 11 153		45°	H	<b>VAG96123</b> ■ 42.25 x 7.02 x 13.05
<b>V91934</b> ■ 28.00 x 7.00 x 108.60	608 11 154		45°	ss	<b>VAG96230</b> ■ 46.00 x 7.02 x 13.06
<b>V94591</b> ■ 28.00 x 7.00 x 108.80	606 74 496		45°	ss	

AA5420 MLS, 0.380mm	CA5420	<b>JD271</b> ■ (Metal) <b>JD273</b> ■ MLS	<b>HL700</b> ■	<b>HR599</b> ■	<b>NA5053</b> 30.00x42.00x7.00mm FPM



AA5420

## 352



83.00

Petrol



AR 67299      4 Cyl.      10:1      1970cc      110-114kW (150-155)PS      TD23351      1041

<b>TB468</b> 168x24 <b>TB607</b> 126x15 Eng.→0117877 Driven unit: balance shaft	<b>TBK356</b> Component No: TB468; AE1147TP;AE1042TP				<b>FOL106</b> (x16) Height: 24mm <b>FOL145</b> (x16) Height: 26mm







BW710 Fibre Composite, 1.650mm	<b>DW710</b> →10/96 <b>DW711</b> 01/97→	<b>JD271</b> ■ (Metal) <b>JD273</b> ■ MLS	<b>HR646</b> ■	<b>NA5053</b> 30.00x42.00x7.00mm FPM <b>NA5069</b> 55.00x68.00x8.00mm FPM











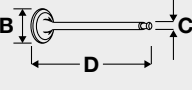



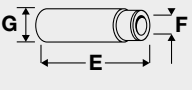

BW710

**353**  **83.00** **Petrol** 

AR 67202 4 Cyl. 10:1 1995cc 104kW (141)PS TD137 1042

					
					<b>FOL106</b> (x8) Height: 24mm <b>FOL145</b> (x20) Height: 26mm

	OE				
B x C x D		MAT.	45°		E x F x G
<b>V91308</b> ■ 44.00 x 8.00 x 116.00	605 64 098	 MD cr			<b>VAG96260B</b> ■ 48.00 x 8.00 x 15.07 <b>VAG96268</b> ■ 45.00 x 8.00 x 15.07







							
<b>BW410</b> Fibre Composite	<b>DW410</b>	<b>GW410</b>		<b>JD235</b> ■ <b>JD015</b> ■ (x4)	<b>JN940</b>	<b>HR363</b> ■	<b>NA5163</b> 32.00x47.00x10.00mm FPM











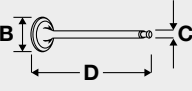



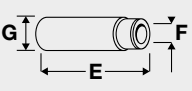



BW410

**354**  **83.00** **Petrol** 

192 A2.000 5 Cyl. 10.5:1 2446cc 117-125kW (159-170)PS TD16396 1044

					
					<b>FOL106</b> (x20) Height: 24mm <b>FOL145</b> (x20) Height: 26mm

	OE				
B x C x D		MAT.	45°		E x F x G
<b>V91933</b> ■ 33.40 x 7.00 x 113.10	608 11 153	 MB cr	45°	H	<b>VAG96123</b> ■ 42.25 x 7.02 x 13.05
<b>V91934</b> ■ 28.00 x 7.00 x 108.60	608 11 154	 MD cr	45°	ss	<b>VAG96146</b> ■ 42.50 x 7.04 x 13.05
<b>V94582</b> ■ 28.00 x 7.00 x 108.50	7 766 565	 MD cr	45°		<b>VAG96145</b> ■ 46.00 x 7.02 x 13.03
<b>V94591</b> ■ 28.00 x 7.00 x 108.80	606 74 496	 MG cr	45°	ss H	<b>VAG96230</b> ■ 46.00 x 7.02 x 13.06

							
<b>AA5590</b> MLS, 0.490mm	<b>CA5590</b>		<b>HBS133</b> ☼ M10x1.25x254.00mm (x12)	<b>JD225</b> ■ <b>JD226</b> ■	<b>JM5018</b> (Elastomer)	<b>HR800</b> ■	<b>NA5053</b> 30.00x42.00x7.00mm FPM <b>NA5069</b> 55.00x68.00x8.00mm FPM



AA5590

# FIAT GROUP







**355**







 **83.00**



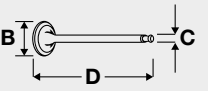

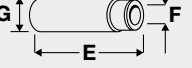

**Petrol**



<b>838 A2.000</b>	5 Cyl.	10:1	2446cc	<b>129kW (175)PS</b>	<b>TD4617</b>	<b>1045</b>
<b>838 A2.027</b>	5 Cyl.	10:1	2446cc	<b>129kW (175)PS</b>	<b>TD14528</b>	<b>1045</b>

					
<b>TB468</b> 168x24			<b>KIT</b>		<b>FOL106</b> (x20) Height: 24mm <b>FOL145</b> (x20) Height: 26mm

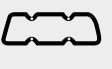

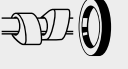
	OE	MAT.			
B x C x D					E x F x G
<b>V91933</b> ■ 33.40 x 7.00 x 113.10	608 11 153	 MB cr	45°	H	<b>VAG96123</b> ■ 42.25 x 7.02 x 13.05
<b>V91934</b> ■ 28.00 x 7.00 x 108.60	608 11 154	 MD cr	45°	ss	<b>VAG96146</b> ■ 42.50 x 7.04 x 13.05
<b>V94582</b> ■ 28.00 x 7.00 x 108.50	7 766 565	 MD cr	45°		<b>VAG96145</b> ■ 46.00 x 7.02 x 13.03
<b>V94591</b> ■ 28.00 x 7.00 x 108.80	606 74 496	 MG cr	45°	ss H	<b>VAG96230</b> ■ 46.00 x 7.02 x 13.06







							
<b>BW330</b> Fibre Composite			<b>HBS133</b> ☒ M10x1.25x254.00mm (x12)	<b>JD226</b> ■	<b>JN933</b>	<b>HR800</b> ■	<b>NA5053</b> 30.00x42.00x7.00mm FPM











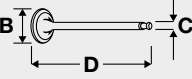



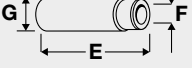















**BW330**



<b>356</b>	 <b>83.00</b>	<b>Petrol</b>				
<b>838 B2.000</b>	5 Cyl.	10:1	2446cc	<b>129kW (175)PS</b>	<b>TD18864</b>	<b>1043</b>

					
					<b>FOL106</b> (x20) Height: 24mm <b>FOL145</b> (x20) Height: 26mm

	OE	MAT.				
B x C x D						E x F x G
<b>V91933</b> 	608 11 153	 MB cr	45°		H	<b>VAG96123</b>  42.25 x 7.02 x 13.05
<b>V91934</b> 	608 11 154	 MD cr	45°	ss		<b>VAG96146</b>  42.50 x 7.04 x 13.05
<b>V94582</b> 	7 766 565	 MD cr	45°			<b>VAG96145</b>  46.00 x 7.02 x 13.03
<b>V94591</b> 	606 74 496	 MG cr	45°	ss	H	<b>VAG96230</b>  46.00 x 7.02 x 13.06

							
<b>BW321</b> Fibre Composite				<b>JD225</b>  <b>JD226</b> 		<b>HR602</b> 	<b>NA5053</b> 30.00x42.00x7.00mm FPM



BW321

# FIAT GROUP

## 357

83.00

Petrol



841 D.000      5 Cyl.      10.3:1      2446cc      125kW (170)PS      TD16732      1043

	.KIT		KIT		
<b>TB468</b> 168x24 →08/06				<b>FOL106</b> (x20) Height: 24mm <b>FOL145</b> (x20) Height: 26mm	

 B x C x D	OE	MAT.				 E x F x G
<b>V91933</b>	608 11 153	MB cr	45°		H	<b>VAG96123</b> 42.25 x 7.02 x 13.05
<b>V91934</b>	608 11 154	MD cr	45°	ss		<b>VAG96146</b> 42.50 x 7.04 x 13.05
<b>V94582</b>	7 766 565	MD cr	45°			<b>VAG96145</b> 46.00 x 7.02 x 13.03
<b>V94591</b>	606 74 496	MG cr	45°	ss	H	<b>VAG96230</b> 46.00 x 7.02 x 13.06

AD5960 MLS			HBS133 M10x1.25x254.00mm (x12)	JD225 JD226		HR816	NA5053 30.00x42.00x7.00mm FPM



AD5960

## 358

83.40

Petrol



AR 67103      4 Cyl.      10.3:1      1748cc      83kW (113)PS      TD134      1046

 B x C x D	OE	MAT.				 E x F x G
<b>V91308</b>	605 64 098	MD cr	45°			<b>VAG96260B</b> 48.00 x 8.00 x 15.07
						<b>VAG96268</b> 45.00 x 8.00 x 15.07

BW410 Fibre Composite	DW410	GW410		JD235 JD015  (x4)	JN940	HR363	



BW410

<b>359</b>	<b>83.50</b>	<b>Petrol</b>	
<b>AR 67105</b>	4 Cyl.	10.3:1	1748cc
<b>83-85kW (113-115)PS</b>			<b>TD135 1047</b>

<p>B x C x D</p>	OE	MAT.		<p>E x F x G</p>
<b>V91308</b> ■ 44.00 x 8.00 x 116.00	605 64 098	 MD cr	45°	<b>VAG96260B</b> ■ 48.00 x 8.00 x 15.07 <b>VAG96268</b> ■ 45.00 x 8.00 x 15.07

<b>BW410</b> Fibre Composite	<b>DW410</b>	<b>GW410</b>		<b>JD235</b> ■ <b>JD015</b> ■ (x4)	<b>JN940</b>	<b>HR363</b> ■	



**BW410**

<b>360</b>	<b>84.00</b>	<b>Petrol</b>	
<b>AR 30184</b>	4 Cyl.	9:1	1286cc
<b>55kW (75)PS</b>			<b>TD85 1048</b>

<b>TB106</b> 98x17			<b>KIT</b>		



<p>B x C x D</p>	OE	MAT.		<p>E x F x G</p>
<b>V91629</b> ■ 39.80 x 8.00 x 92.00	605 40 326	 MB	45°	<b>VAG96261</b> ■ 40.50 x 8.02 x 13.08
<b>V91630</b> ■ 33.10 x 8.00 x 92.10	605 40 325	 MD cr	45°	







<b>BE620</b> Fibre Composite (x2)	<b>CN353</b> <b>DE622</b>			<b>JA899</b> ■ (x4)	<b>JN588</b> (x2)		<b>NA5064</b> 35.00x58.00x10.00mm ACM











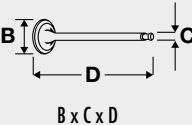
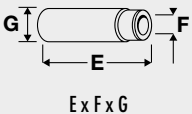





**BE620**

# FIAT GROUP



<b>361</b>	 <b>84.00</b>	<b>Petrol</b>				
AR 30124	4 Cyl.	9:1	1490cc	<b>61-64kW (83-87)PS</b>	<b>TD78</b>	<b>1049</b>
AR 30128	4 Cyl.	9:1	1490cc	<b>70kW (95)PS</b>	<b>TD79</b>	<b>1049</b>
AR 30520	4 Cyl.	9:1	1490cc	<b>66kW (90)PS</b>	<b>TD91</b>	<b>1049</b>



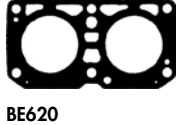

					
<b>TB106</b>			<b>KIT</b>		
98x17					

	
B x C x D	E x F x G
OE	
	
MAT.	45°
	
MB	H
	
MD cr	<b>VAG96261</b>
<b>V91629</b>	40.50 x 8.02 x 13.08
39.80 x 8.00 x 92.00	
<b>V91630</b>	
33.10 x 8.00 x 92.10	

							
<b>BE620</b> Fibre Composite (x2)	<b>DE622</b>			<b>JA899</b> (x4)	<b>JN588</b> (x2)		<b>NA5064</b>
							35.00x58.00x10.00mm ACM

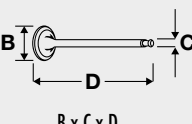
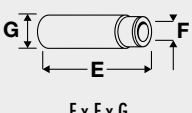

<b>362</b>	 <b>84.00</b>	<b>Petrol</b>				
AR 30143	4 Cyl.		1490cc	<b>62kW (84)PS</b>	<b>TD10131</b>	<b>1050</b>

	
B x C x D	E x F x G
OE	
	
MAT.	45°
	
MD cr	ss
<b>V90392</b>	
33.10 x 8.00 x 92.90	

<b>363</b>	<b>84.00</b>	<b>Petrol</b>				
AR 30146	4 Cyl.	9.5:1	1490cc	75-77kW (102-105)PS	TD80	1049
AR 30508	4 Cyl.		1490cc	77kW (105)PS	TD90	1049

<b>TB106</b> 98x17					

	OE		MAT.		45°		Ex F x G
<b>V91615</b>	605 04 784		MD cr			<b>VAG96261</b>	40.50 x 8.02 x 13.08
33.00 x 7.98 x 97.50							

<b>BE620</b> Fibre Composite (x2)	<b>DE622</b>				<b>JA899</b> (x4)	<b>JN588</b> (x2)		<b>NA5064</b> 35.00x58.00x10.00mm ACM



<b>364</b>	<b>84.00</b>	<b>Petrol</b>			
AR 30182	4 Cyl.	1490cc	70kW (95)PS	TD10128	1049

<b>TB106</b> 98x17 →12/90 <b>TB338</b> 100x17 01/91→	<b>TBK287</b> 01/91→ Component No: TB338; AE1006TP;AE1007TP				

	OE		MAT.		45°		Ex F x G
<b>V91614</b>	129661		MB cr		H		
38.00 x 8.00 x 97.00							
<b>V91615</b>	605 04 784		MD cr		45°		
33.00 x 7.98 x 97.50							

<b>BE620</b> Fibre Composite (x2)	<b>DE622</b>				<b>JA899</b> (x4)	<b>JN588</b> (x2)		<b>NA5064</b> 35.00x58.00x10.00mm ACM



# FIAT GROUP

<b>365</b>	<b>84.00</b>	<b>Petrol</b>	
<b>AR 30504</b>	4 Cyl.	9:1	1490cc
			<b>62kW (84)PS</b>
			<b>TD89 1049</b>

<b>TB106</b>					
98x17					

B x C x D	OE	MAT.	45°	ss	E x F x G
<b>V90392</b>	10289.60000.00				
33.10 x 8.00 x 92.90		MD cr			

<b>BE620</b> Fibre Composite	<b>DE622</b>						<b>NA5064</b>
							35.00x58.00x10.00mm ACM

<b>BE620</b>					

<b>366</b>	<b>84.00</b>	<b>Petrol</b>	
<b>AR 30514</b>	4 Cyl.	1490cc	<b>70kW (95)PS</b>
			<b>TD6373 1052</b>

<b>TB106</b>					
98x17					

B x C x D	OE	MAT.	45°	H	E x F x G
<b>V91629</b>	605 40 326				<b>VAG96261</b>
39.80 x 8.00 x 92.00		MB			40.50 x 8.02 x 13.08
<b>V91630</b>	605 40 325				
33.10 x 8.00 x 92.10		MD cr			

367		84.00		Petrol			
AR 30588		4 Cyl.		1490cc		75-77kW (102-105)PS	
TD98		1053					
<b>TB106</b> 98x17							
	OE	MAT.					
<b>V91614</b>	129661		45°		H	<b>VAG96261</b>	
38.00 x 8.00 x 97.00		MB cr				40.50 x 8.02 x 13.08	
<b>V91627</b>	605 03 993		45°	ss	H		
33.00 x 8.00 x 93.50		MG cr					
<b>BE620</b> Fibre Composite (x2)	<b>DE622</b>	<b>JA899</b> (x4)	<b>JN588</b> (x2)	<b>NA5064</b> 35.00x58.00x10.00mm ACM			
<b>BE620</b>							
368		84.00		Petrol			
AR 30734		4 Cyl.		1490cc		77kW (105)PS	
TD108		1051					
<b>TB106</b> 98x17 →12/90		<b>TBK287</b> 01/91→ Component No: TB338; AE1006TP;AE1007TP					
<b>TB338</b> 100x17 01/91→							
	OE	MAT.					
<b>V91629</b>	605 40 326		45°		H	<b>VAG96261</b>	
39.80 x 8.00 x 92.00		MB				40.50 x 8.02 x 13.08	
<b>V91630</b>	605 40 325		45°				
33.10 x 8.00 x 92.10		MD cr					

# FIAT GROUP







**369**







 **84.00**



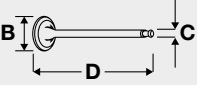

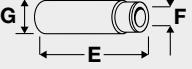

**Petrol**



AR 30750      4 Cyl.      1490cc      74kW (101)PS      TD116      **1054**

			 <b>KIT</b>		
<b>TB106</b> 98x17 →12/90 <b>TB338</b> 100x17 01/91→	<b>TBK287</b> 01/91→ Component No: TB338; AE1006TP;AE1007TP				

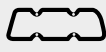
	OE				
<b>V91629</b> ■ 39.80 x 8.00 x 92.00	605 40 326		45°	H	<b>VAG96261</b> ■ 40.50 x 8.02 x 13.08
<b>V91630</b> ■ 33.10 x 8.00 x 92.10	605 40 325		45°		

							
<b>BE620</b> Fibre Composite (x2)	<b>DE623</b>			<b>JD221</b> (x2) <b>JA899</b> ■ (x4)	<b>JN588</b> (x2)	<b>HR363</b> ■	<b>NA5064</b> 35.00x58.00x10.00mm ACM



BE620







**370**







 **84.00**





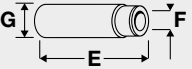

**Petrol**



AR 30751      4 Cyl.      1490cc      71-72kW (97-98)PS      TD117      **1054**

			 <b>KIT</b>		
<b>TB106</b> 98x17 →12/90 <b>TB388</b> 121x15 01/91→ Length: 1152.5mm Groove Distance: 9.525	<b>TBK287</b> 01/91→ Component No: TB338; AE1006TP;AE1007TP				

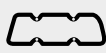











	OE				
<b>V91629</b> ■ 39.80 x 8.00 x 92.00	605 40 326		45°	H	<b>VAG96261</b> ■ 40.50 x 8.02 x 13.08
<b>V91630</b> ■ 33.10 x 8.00 x 92.10	605 40 325		45°		



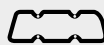

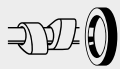









							
<b>BE620</b> Fibre Composite (x2)	<b>DE623</b>			<b>JD221</b> (x2) <b>JA899</b> ■ (x4)	<b>JN588</b> (x2)	<b>HR363</b> ■	<b>NA5064</b> 35.00x58.00x10.00mm ACM















BE620

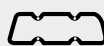

<b>371</b>	 <b>84.00</b>	<b>Petrol</b>					
124 B3.000	4 Cyl.	8.9:1	1585cc	46kW (63)PS	TD6898	<b>1055</b>	
							
BP190 Fibre Composite	DP190			 JE390 		HR569 	
							
BP190							

<b>372</b>	 <b>84.00</b>	<b>Petrol</b>					
131 A1.000	4 Cyl.	9.2:1	1585cc	55kW (75)PS	TD896	<b>1056</b>	
							
BP130 Fibre Composite	DP130			JA777  (Graphite) JA757   JE390		HR363 	NA5187 30.00x52.00x7.00mm ACM
							
BP130							

<b>373</b>	 <b>84.00</b>	<b>Petrol</b>					
131 B1.000	4 Cyl.	9:1	1585cc	72kW (98)PS	TD901	<b>1058</b>	
							
BK540 Fibre Composite	DP130			JA777  (Graphite) JA757 	JM085 (x2) JM508		NA5187 30.00x52.00x7.00mm ACM
							
BK540							

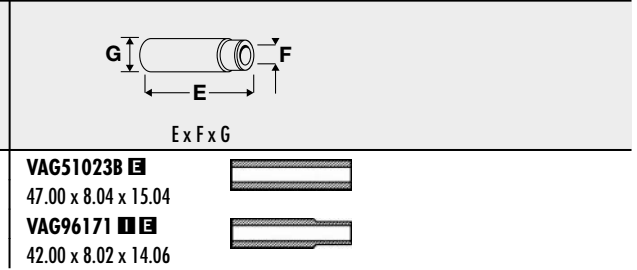
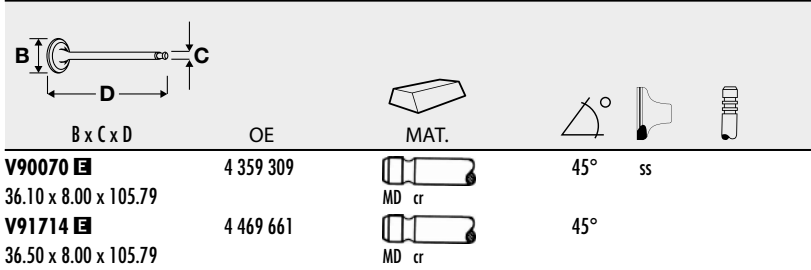

# FIAT GROUP

## 374

 84.00

Petrol



131 C2.000

4 Cyl.











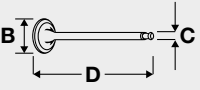

9.1:1

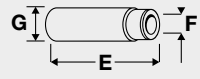







1585cc

63kW (85)PS

TD4351

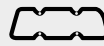
1059

 B x C x D	OE	MAT.				 E x F x G
<b>V91765</b> 	7 547 400	 MB cr	45°		H	<b>VAG96171</b>  42.00 x 8.02 x 14.06
<b>V90070</b> 	4 359 309	 MD cr	45°	ss		
<b>V91714</b> 	4 469 661	 MD cr	45°			

							
BK540 Fibre Composite				JA777  (Graphite) JA757 	JM085 (x2) JM508		NA5187 30.00x52.00x7.00mm ACM



BK540

## 375

 84.00

Petrol



131 C3.000









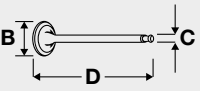

4 Cyl.



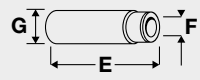







1585cc

71-72kW (96-98)PS

TD904

1060

 B x C x D	OE	MAT.				 E x F x G
<b>V90070</b> 	4 359 309	 MD cr	45°	ss		<b>VAG96171</b>  42.00 x 8.02 x 14.06
<b>V91714</b> 	4 469 661	 MD cr	45°			

							
BP190 Fibre Composite	DP190			JE390 	JM085 JN459	HR596 	



BP190

<b>376</b>	<b>84.00</b>	<b>Petrol</b>			
<b>132 C.000</b>	4 Cyl.	9:1	1585cc	<b>65-72kW (89-98)PS</b>	<b>TD909 1058</b>
					<b>FOL104 (x8) [6]</b>

[6] Mechanical      [6] Mécanique      [6] Meccanico      [6] Mecánico

B x C x D	E x F x G
<b>V90070</b>	<b>VAG51023B</b>
36.10 x 8.00 x 105.79	47.00 x 8.04 x 15.04
<b>V91714</b>	<b>VAG96171</b>
36.50 x 8.00 x 105.79	42.00 x 8.02 x 14.06

<b>BK540</b> Fibre Composite	<b>DP130</b>			<b>JA777</b> (Graphite) <b>JA757</b>	<b>JM085</b> (x2) <b>JM508</b>		<b>NA5187</b> 30.00x52.00x7.00mm ACM



BK540

<b>377</b>	<b>84.00</b>	<b>Petrol</b>			
<b>132 C6.000</b>	4 Cyl.		1585cc	<b>66kW (90)PS</b>	<b>TD912 1061</b>
<b>134 AS.000</b>	4 Cyl.	8.9:1	1995cc	<b>88kW (120)PS</b>	<b>TD1781 1078</b>

<b>BK540</b> Fibre Composite	<b>DP133</b>			<b>JA757</b> <b>JE744</b>	<b>JM508</b> <b>JN643</b>		<b>NA5187</b> 30.00x52.00x7.00mm ACM



BK540

# FIAT GROUP

<b>378</b>	<b>84.00</b>	<b>Petrol</b>				
<b>132 D.000</b>	4 Cyl.	9:1	1585cc	<b>72kW (98)PS</b>	<b>TD911</b>	<b>1058</b>
<b>TB148</b> 68x15 Driven unit: power-steering pump						<b>FOL104 (x8) [6]</b>
<b>TB112</b> 144x19 Eng.→1480467						
<b>TB200</b> 143x19 Eng.1480468→						
[6] Mechanical	[6] Mécanique	[6] Meccanico	[6] Mecánico			

B x C x D	E x F x G
<b>V90070</b>	<b>VAG51023B</b>
36.10 x 8.00 x 105.79	47.00 x 8.04 x 15.04
<b>V91714</b>	<b>VAG96171</b>
36.50 x 8.00 x 105.79	42.00 x 8.02 x 14.06

<b>BK540</b> Fibre Composite	<b>DP130</b>			<b>JA777</b> (Graphite)	<b>JM085 (x2)</b> <b>JM508</b>		<b>NA5187</b> 30.00x52.00x7.00mm ACM
				<b>JA757</b>			



BK540

<b>379</b>	<b>84.00</b>	<b>Petrol</b>				
<b>138 AR.000</b>	4 Cyl.	9.3:1	1585cc	<b>66-77kW (90-105)PS</b>	<b>TD919</b>	<b>1058</b>
<b>TB112</b> 144x19 Eng.→1484451						
<b>TB200</b> 143x19 Eng.1484452→4880207						
<b>TB249</b> 138x18 Eng.4880208→						
<b>BK540</b> Fibre Composite	<b>DP130</b>			<b>JA777</b> (Graphite)	<b>JM085 (x2)</b> <b>JM508</b>	<b>HR363</b>
				<b>JA757</b>		



BK540

<b>380</b>	<b>84.00</b>	<b>Petrol</b>				
<b>149 A2.000</b>	4 Cyl.	9.3:1	1585cc	<b>74kW (101)PS</b>	<b>TD4379</b>	<b>1064</b>
<b>TB249</b> 138x18 <b>TB112</b> 144x19 Eng.→1484418 <b>TB200</b> 143x19 Eng.1484419→						

B x C x D	OE					E x F x G
<b>V91765</b>	7 547 400		45°	H	<b>VAG96171</b>	
43.50 x 8.00 x 105.00		MB cr			42.00 x 8.02 x 14.06	
<b>V91394</b>	5 953 041		45°	ss		
36.50 x 8.00 x 105.50		MD				

















			<b>HBS011</b>	<b>JA757</b>	<b>LB414</b>	<b>HR363</b>	
			M12x1.25x119.00mm (x12)				
			<b>HBS051</b>				
			M10x1.25x98.00mm (x5)				





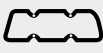

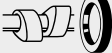









<b>381</b>	<b>84.00</b>	<b>Petrol</b>				
<b>149 A4.000</b>	4 Cyl.	9.3:1	1585cc	<b>74kW (101)PS</b>	<b>TD4380</b>	<b>1065</b>
<b>TB249</b> 138x18 <b>TB112</b> 144x19 Eng.→1484418 <b>TB200</b> 143x19 Eng.1484419→						





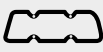

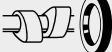









B x C x D	OE					E x F x G
<b>V91765</b>	7 547 400		45°	H	<b>VAG96171</b>	
43.50 x 8.00 x 105.00		MB cr			42.00 x 8.02 x 14.06	
<b>V91394</b>	5 953 041		45°	ss		
36.50 x 8.00 x 105.50		MD				

			<b>HBS011</b>	<b>JA757</b>	<b>JN644</b>	<b>HR363</b>	
			M12x1.25x119.00mm (x12)		<b>LB414</b>		
			<b>HBS051</b>				
			M10x1.25x98.00mm (x5)				

# FIAT GROUP

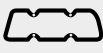
<b>382</b>  <b>84.00</b> <b>Petrol</b> 							
<b>149 C2.000</b>	<b>4 Cyl.</b> <b>9.5:1</b> <b>1585cc</b> <b>66kW (90)PS</b> <b>TD5432</b> <b>1066</b>						
 	 						
<b>TB249</b> 138x18							
							
<b>BT410</b> Fibre Composite	<b>DT411</b> [1] <b>DT423</b>		<b>HBS092</b>  M10x1.25x115.00mm (x10)				
							
<b>BT410</b>	[1] Without crankshaft seal	[1] sans bague d'étanchéité - vilebrequin	[1] senza paraolio-albero a gomiti	[1] sin cigüeñal retén			

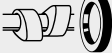
<b>383</b>  <b>84.00</b> <b>Petrol</b> 							
<b>149 C3.000</b>	<b>4 Cyl.</b> <b>9.5:1</b> <b>1585cc</b> <b>61-76kW (83-103)PS</b> <b>TD18856</b> <b>1063</b>						
 	 						
<b>TB249</b> 138x18 <b>TB112</b> 144x19 Eng.→1484418 <b>TB200</b> 143x19 Eng.1484419→							
							
			<b>HBS092</b>  M10x1.25x115.00mm (x10)				

<b>384</b>  <b>84.00</b> <b>Petrol</b> 							
<b>154 A.048</b>	<b>4 Cyl.</b> <b>9.75:1</b> <b>1585cc</b> <b>61kW (83)PS</b> <b>TD11754</b> <b>1067</b>						
 	 						
<b>TB246</b> 110x18							
							
			<b>JC287</b>		<b>HR596</b> 	<b>NA5187</b> 30.00x52.00x7.00mm ACM	

<b>385</b>	<b>84.00</b>	<b>Petrol</b>				
<b>828 B.000</b>	4 Cyl.	9.3:1	1585cc	<b>74kW (100)PS</b>	<b>TD1796</b>	<b>1068</b>
<b>828 B1.000</b>	4 Cyl.	8.9:1	1995cc	<b>85-88kW (116-119)PS</b>	<b>TD1797</b>	<b>1068</b>

[6] Mechanical	[6] Mécanique	[6] Meccanico	[6] Mecánico		<b>FOL104 (x8) [6]</b>

B x C x D	E x F x G
<b>V90070</b>	<b>VAG51023B</b>
4 359 309	47.00 x 8.04 x 15.04
36.10 x 8.00 x 105.79	<b>VAG96171</b>
<b>V91714</b>	42.00 x 8.02 x 14.06
4 469 661	
36.50 x 8.00 x 105.79	

	DP133						

<b>386</b>	<b>84.00</b>	<b>Petrol</b>				
<b>831 A4.000</b>	4 Cyl.	9.5:1	1585cc	<b>77kW (105)PS</b>	<b>TD4604</b>	<b>1069</b>

<b>TB112</b> 144x19 Eng.→488950					<b>FOL38 (x8)</b>
<b>TB200</b> 143x19 Eng.488951 →					

B x C x D	E x F x G
<b>V91290</b>	<b>VAG96171</b>
46 406 169	42.00 x 8.02 x 14.06
43.50 x 8.00 x 105.70	
<b>V91765</b>	
7 547 400	
43.50 x 8.00 x 105.00	
<b>V90070</b>	
4 359 309	
36.10 x 8.00 x 105.79	
<b>V91394</b>	
5 953 041	
36.50 x 8.00 x 105.50	
<b>V91636</b>	
5 975 341	
36.50 x 8.00 x 106.00	

<b>BT440</b> Fibre Composite	<b>DT411</b> [1]		<b>HBS051</b>				
			M10x1.25x98.00mm (x5)				



















**BT440**  
[1] Without crankshaft seal





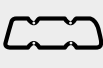

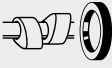









[1] sans bague d'étanchéité - vilebrequin





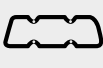

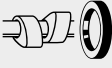

[1] senza paraolio-albero a gomiti











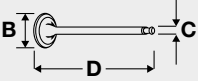
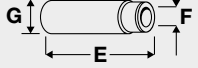







[1] sin cigüeñal retén

# FIAT GROUP

<b>387</b>	 <b>84.00</b>	<b>Petrol</b>					
<b>831 A7.000</b>	4 Cyl.	8:1	1585cc	<b>96kW (130)PS</b>	<b>Turbo Intercooled</b>	<b>TD1808</b>	<b>1070</b>
							
<b>TB112</b> 144x19 Eng. → 488950 <b>TB200</b> 143x19 Eng. 488951 →							
							
			<b>HBS092</b>  M10x1.25x115.00mm (x10)	<b>JD5997</b> 			

<b>388</b>	 <b>84.00</b>	<b>Petrol</b>					
<b>831 B3.000</b>	4 Cyl.	8:1	1585cc	<b>103kW (140)PS</b>	<b>Turbo Intercooled</b>	<b>TD1807</b>	<b>1071</b>
							
<b>TB249</b> 138x18							
							
<b>BT420</b> Fibre Composite							
							

<b>389</b>	 <b>84.00</b>	<b>Petrol</b>					
<b>831 B6.000</b>	4 Cyl.	1585cc	<b>73kW (99)PS</b>	<b>TD1815</b>	<b>1072</b>		
							
<b>TB249</b> 138x18 → 07/90						<b>FOL38</b> (x8)	

					
B x C x D	OE	MAT.			
<b>V91290</b> 	46 406 169		45°		H
43.50 x 8.00 x 105.70		MB			
<b>V91765</b> 	7 547 400		45°		H
43.50 x 8.00 x 105.00		MB cr			
<b>V90070</b> 	4 359 309		45°	ss	
36.10 x 8.00 x 105.79		MD cr			
<b>V91394</b> 	5 953 041		45°	ss	
36.50 x 8.00 x 105.50		MD			
<b>V91636</b> 	5 975 341		45°		
36.50 x 8.00 x 106.00		MD cr			
					<b>VAG96171</b>    42.00 x 8.02 x 14.06 



<b>390</b>	<b>84.00</b>	<b>Petrol</b>				
<b>831 B7.000</b>	4 Cyl.	9.5:1	1585cc	<b>80kW (109)PS</b>	<b>TD1817</b>	<b>1066</b>
<b>TB249</b>						
138x18						

B x C x D	OE	MAT.			E x F x G
<b>V91290</b>	46 406 169		45°	H	<b>VAG96171</b>
43.50 x 8.00 x 105.70		MB			42.00 x 8.02 x 14.06
<b>V91765</b>	7 547 400		45°	H	
43.50 x 8.00 x 105.00		MB cr			
<b>V90070</b>	4 359 309		45°	ss	
36.10 x 8.00 x 105.79		MD cr			
<b>V91394</b>	5 953 041		45°	ss	
36.50 x 8.00 x 105.50		MD			
<b>V91636</b>	5 975 341		45°		
36.50 x 8.00 x 106.00		MD cr			

<b>DT411</b> [1]			<b>HBS051</b>	<b>JC662</b>	<b>JN643</b> (x2)	<b>HR363</b>		
<b>DT423</b>			M10x1.25x98.00mm (x5)	<b>JA757</b>	<b>JN645</b>			
[1] Without crankshaft seal		[1] sans bague d'étanchéité - vilebrequin		[1] senza paraolio-albero a gomiti		[1] sin cigüeñal retén		

<b>391</b>	<b>84.00</b>	<b>Petrol</b>					
<b>831 B7.046</b>	4 Cyl.	9.5:1	1585cc	<b>97kW (132)PS</b>	<b>Turbo Intercooled</b>	<b>TD4606</b>	<b>1073</b>
<b>TB249</b>							<b>FOL38</b> (x8)
138x18							

B x C x D	OE	MAT.			E x F x G
<b>V91290</b>	46 406 169		45°	H	<b>VAG96171</b>
43.50 x 8.00 x 105.70		MB			42.00 x 8.02 x 14.06
<b>V91765</b>	7 547 400		45°	H	
43.50 x 8.00 x 105.00		MB cr			
<b>V90070</b>	4 359 309		45°	ss	
36.10 x 8.00 x 105.79		MD cr			
<b>V91394</b>	5 953 041		45°	ss	
36.50 x 8.00 x 105.50		MD			
<b>V91636</b>	5 975 341		45°		
36.50 x 8.00 x 106.00		MD cr			

<b>DT411</b> [1]			<b>HBS051</b>					
			M10x1.25x98.00mm (x5)					
[1] Without crankshaft seal		[1] sans bague d'étanchéité - vilebrequin		[1] senza paraolio-albero a gomiti		[1] sin cigüeñal retén		

# FIAT GROUP

<b>392</b>	<b>84.00</b>	<b>Petrol</b>				
<b>149 C2.046</b>	4 Cyl.	9.5:1	1595cc	<b>66kW (90)PS</b>	<b>TD978</b>	<b>1063</b>
	<b>.KIT</b>		<b>KIT</b>			
<b>TB249</b> 138x18 →10/90						

<b>BT420</b> Fibre Composite	<b>DT423</b>		<b>HBS092</b> ☒ M10x1.25x115.00mm (x10)				



BT420

<b>393</b>	<b>84.00</b>	<b>Petrol</b>				
<b>AR 33201</b>	4 Cyl.	9.5:1	1596cc	<b>76kW (103)PS</b>	<b>TD121</b>	<b>1074</b>
	<b>.KIT</b>		<b>KIT</b>			
<b>TB338</b> 100x17	<b>TBK287</b> Component No: TB338; AE1006TP;AE1007TP					

<b>V91629</b> ■ 39.80 x 8.00 x 92.00	<b>605 40 326</b>	<b>MAT.</b>	45°	<b>H</b>	<b>VAG96261</b> ■ ■ ■ 40.50 x 8.02 x 13.08		
<b>V91630</b> ■ 33.10 x 8.00 x 92.10	<b>605 40 325</b>	<b>MD cr</b>	45°				

<b>BE620</b> Fibre Composite (x2)	<b>DE623</b>			<b>JD221</b> (x2) <b>JA899</b> ■ (x4)	<b>JN588</b> (x2)	<b>HR363</b> ■	<b>NA5064</b> 35.00x58.00x10.00mm ACM













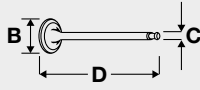

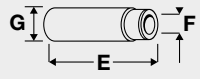





BE620









<b>394</b>	<b>84.00</b>	<b>Petrol</b>				
<b>132 AC1.000</b>	4 Cyl.	9.8:1	1756cc	<b>87kW (118)PS</b>	<b>TD23121</b>	<b>1076</b>
<b>BP130</b> Fibre Composite	<b>DP130</b>					<b>NA5187</b> (x2) 30.00x52.00x7.00mm ACM

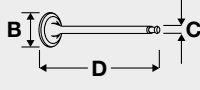

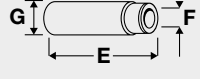







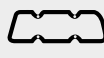

BP130

<b>395</b>	 <b>84.00</b>	<b>Petrol</b>				
<b>132 B.000</b>	4 Cyl.	8.9:1	1756cc	<b>79kW (107)PS</b>	<b>TD18854</b>	<b>1077</b>
	B x C x D	OE	MAT.			E x F x G
<b>V90070</b> 	4 359 309		45°	ss	<b>VAG51023B</b> 	
36.10 x 8.00 x 105.79		MD cr			47.00 x 8.04 x 15.04	
<b>V91714</b> 	4 469 661		45°		<b>VAG96171</b> 	
36.50 x 8.00 x 105.79		MD cr			42.00 x 8.02 x 14.06	

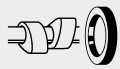







<b>396</b>	 <b>84.00</b>	<b>Petrol</b>				
<b>132 B1.000</b>	4 Cyl.	8.9:1	1756cc	<b>77-82kW (105-112)PS</b>	<b>TD906</b>	<b>1079</b>
						<b>FOL104</b> (x8) [6]
[6] Mechanical	[6] Mécanique	[6] Meccanico	[6] Mecánico			

	B x C x D	OE	MAT.			E x F x G
<b>V90070</b> 	4 359 309		45°	ss	<b>VAG51023B</b> 	
36.10 x 8.00 x 105.79		MD cr			47.00 x 8.04 x 15.04	
<b>V91714</b> 	4 469 661		45°		<b>VAG96171</b> 	
36.50 x 8.00 x 105.79		MD cr			42.00 x 8.02 x 14.06	

							
<b>BP130</b> Fibre Composite	<b>DP130</b>			<b>JA777</b>  (Graphite) <b>JA757</b> 	<b>JM085</b> (x2) <b>JM508</b>	<b>HR596</b> 	

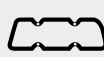

BP130

<b>397</b>	 <b>84.00</b>	<b>Petrol</b>					
<b>132 C1.000</b>	4 Cyl.	8.9:1	1756cc	<b>77-82kW (105-112)PS</b>	<b>TD19054</b>	<b>1075</b>	
							
					<b>JM085</b>		

**398**

 **84.00**

**Petrol**



159 A4.000

4 Cyl.







9.5:1









1756cc

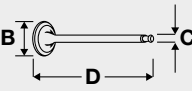



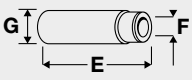

74-81kW (101-110)PS

TD1008

**1080**

					
<b>TB579</b> 97x15 Driven unit: balance shaft	<b>TBK118</b> Eng.→1066635 Component No: TB303; AE1012TP				
<b>TB303</b> 142x18 Eng.→1066635					
<b>TB299</b> 139x18 Eng.1066636→					

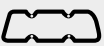
						
B x C x D	OE	MAT.				E x F x G
<b>V91290</b> ■■ 43.50 x 8.00 x 105.70	46 406 169	 MB	45°		H	<b>VAG96171</b> ■■ ■■ 42.00 x 8.02 x 14.06
<b>V91765</b> ■■ 43.50 x 8.00 x 105.00	7 547 400	 MB cr	45°		H	
<b>V91305</b> ■■ 36.50 x 8.00 x 106.00	7 597 080	 MD cr	45°			

							
<b>BT440</b> Fibre Composite	<b>DT446</b>	<b>GT446</b> [1]	<b>HBS092</b> ☒ M10x1.25x115.00mm (x10)	<b>JC662</b> ■■ <b>JD019</b> ■■ 01/92→	<b>JN643</b> (x2) <b>JN948</b> <b>JN819</b> (x2) 01/92→	<b>HR363</b> ■■	<b>NA5187</b> 30.00x52.00x7.00mm ACM



**BT440**  
[1] Without crankshaft seal

[1] sans bague d'étanchéité - vilebrequin

[1] senza paraolio-albero a gomiti

[1] sin cigüeñal retén

<b>399</b>	<b>84.00</b>	<b>Petrol</b>			
159 A4.046	4 Cyl.	9.5:1	1756cc	77kW (105)PS	TD1009 <b>1080</b>

<b>TB299</b> 139x18 →12/92	<b>TBK118</b> 01/93→ Component No: TB303; AE1012TP		<b>KIT</b>		
<b>TB303</b> 142x18 01/93→					
<b>TB579</b> 97x15 01/93→					
Driven unit: balance shaft					

B x C x D	E x F x G
OE	
MAT.	
<b>V91290</b> ■	<b>VAG96171</b> ■ ■ ■
46 406 169	42.00 x 8.02 x 14.06
<b>V91765</b> ■	
7 547 400	
<b>V91305</b> ■	
7 597 080	
36.50 x 8.00 x 106.00	
MB	
MB cr	
MD cr	

<b>BT440</b> Fibre Composite	<b>DT440</b> <b>DT446</b>	<b>GT440</b>	<b>HBS092</b> Ⓢ M10x1.25x115.00mm (x10)	<b>JC662</b> ■ <b>JA757</b> ■	<b>JN948</b>	<b>HR363</b> ■	<b>NA5187</b> 30.00x52.00x7.00mm ACM



**BT440**

# FIAT GROUP

<b>400</b>	<b>84.00</b>	<b>Petrol</b>				
<b>160 A5.000</b>	4 Cyl.	9.9:1	1756cc	<b>100kW (136)PS</b>	<b>TD13669</b>	<b>1081</b>
<b>TB298</b> 168x18 04/90 →						
<b>TB579</b> 97x15 04/90 →						
Driven unit: balance shaft						

B x C x D	OE	MAT.	45°	45°	ss	Ex F x G
<b>V91935</b> ■	7 722 907		45°			<b>VAG92496</b> ■ ■ ■
34.40 x 7.00 x 128.00		MD cr				51.00 x 7.03 x 14.04
<b>V91638</b> ■	7 958 073		45°	ss		<b>VAG96199</b> ■ ■ ■
28.50 x 7.00 x 126.00		MD cr				51.30 x 7.04 x 14.08

<b>BT440</b> Fibre Composite	<b>DT441</b>		<b>HBS093</b> ☒	<b>JD153</b> ■	<b>JN928</b>	<b>HR599</b> ■	<b>NA5053</b>
			M10x1.25x172.00mm (x10)	<b>JD151</b>			30.00x42.00x7.00mm FPM
				<b>JD5997</b> ■			



BT440

<b>401</b>	<b>84.00</b>	<b>Petrol</b>					
<b>835 A2.000</b>	4 Cyl.	9.5:1	1756cc	<b>80kW (108)PS</b>	<b>TD1845</b>	<b>1083</b>	
<b>TB303</b> 142x18	<b>TBK118</b> Component No: TB303; AE1012TP						
<b>TB579</b> 97x15							
Driven unit: balance shaft							
B x C x D	OE	MAT.	45°	45°	H	Ex F x G	
<b>V91290</b> ■	46 406 169		45°			<b>VAG96171</b> ■ ■ ■	
43.50 x 8.00 x 105.70		MB				42.00 x 8.02 x 14.06	
<b>V91305</b> ■	7 597 080		45°				
36.50 x 8.00 x 106.00		MD cr					
	<b>DT410</b>						

## 402

**84.00**
**Petrol**

**835 A2.046**

4 Cyl.

9.5:1

1756cc

**74-77kW (101-105)PS**
**TD1844**
**1084**

<b>TB303</b> 142x18 →06/94 <b>TB579</b> 97x15 Driven unit: balance shaft	<b>TBK118</b> →06/94 Component No: TB303; AE1012TP		<b>KIT</b>		

 B x C x D	OE	 MAT.	 45°	 H	 E x F x G
<b>V91290</b> ■ 43.50 x 8.00 x 105.70	46 406 169	 MB	45°		<b>VAG96171</b> ■ ■ 42.00 x 8.02 x 14.06
<b>V91305</b> ■ 36.50 x 8.00 x 106.00	7 597 080	 MD cr	45°		

<b>BT410</b> Fibre Composite <b>BT420</b> Fibre Composite	<b>DT410</b>	<b>GT410</b>	<b>HBS092</b> ⊗ M10x1.25x115.00mm (x10)	<b>JC662</b> ■ <b>JA757</b> ■	<b>JN643</b> (x2) <b>JN948</b>	<b>HR363</b> ■	

<b>BT410</b>	<b>BT420</b>

## 403



84.00

Petrol



835 C2.000

4 Cyl.

9.5:1

1756cc

76kW (103)PS

TD1068

1085

<b>TB303</b> 142x18 Eng.→1066635 <b>TB299</b> 139x18 Eng.1066636→	<b>TBK118</b> Eng.→1066635 Component No: TB303; AE1012TP				

 B x C x D	OE	 MAT.	 45°	 H	 E x F x G
<b>V91290</b> ■ 43.50 x 8.00 x 105.70	46 406 169	 MB	45°		<b>VAG96171</b> ■ ■ ■ 42.00 x 8.02 x 14.06
<b>V91638</b> ■ 28.50 x 7.00 x 126.00	7 958 073	 MD cr	45° ss		

<b>BT440</b> Fibre Composite	<b>DT446</b> <b>DT449</b>		<b>HBS092</b> ☒ M10x1.25x115.00mm (x10) <b>HBS033</b> ☒ M12x1.75x136.00mm (x10) 07/92→	<b>JC662</b> ■ <b>JD019</b> ■	<b>JN948</b>	<b>HR363</b> ■	<b>NA5187</b> (x2) 30.00x52.00x7.00mm ACM



BT440



<b>404</b>	<b>84.00</b>	<b>Petrol</b>				
<b>835 C2.000</b>	4 Cyl.	9.5:1	1756cc	<b>76kW (103)PS</b>	<b>TD4612</b>	<b>1083</b>
<b>TB303</b> 142x18 11/93→	<b>TBK118</b> 11/93→ Component No: TB303; AE1012TP					
<b>TB579</b> 97x15 11/93→						
Driven unit: balance shaft						

B x C x D	OE				
<b>V91290</b>	46 406 169		45°	H	<b>VAG96171</b>
43.50 x 8.00 x 105.70					42.00 x 8.02 x 14.06
<b>V91305</b>	7 597 080		45°		
36.50 x 8.00 x 106.00					

<b>BT440</b> Fibre Composite	<b>DT449</b>	<b>HBS092</b>	<b>JC662</b>			



BT440

<b>405</b>	<b>84.00</b>	<b>Petrol</b>				
<b>835 C4.000</b>	4 Cyl.	9.5:1	1756cc	<b>66kW (90)PS</b>	<b>TD5433</b>	<b>1084</b>
<b>836 C4.000</b>	4 Cyl.		1756cc	<b>66kW (90)PS</b>	<b>TD5434</b>	<b>1084</b>
<b>TB303</b> 142x18	<b>TBK118</b> Component No: TB303; AE1012TP				<b>FOL38</b> (x8)	
B x C x D	OE					
<b>V91290</b>	46 406 169		45°	H	<b>VAG96171</b>	
43.50 x 8.00 x 105.70					42.00 x 8.02 x 14.06	
<b>V91305</b>	7 597 080		45°			
36.50 x 8.00 x 106.00						
<b>BR620</b> Fibre Composite			<b>JA757</b>			



BR620

# FIAT GROUP

<b>406</b>	<b>84.00</b>	<b>Petrol</b>				
<b>835 C4.000</b>	4 Cyl.	1756cc	<b>66kW (90)PS</b>	<b>TD1069</b>	<b>1086</b>	

<b>TB303</b> 142x18	<b>TBK118</b> Component No: TB303; AE1012TP				

B x C x D	OE	MAT.			E x F x G
<b>V91290</b> ■ 43.50 x 8.00 x 105.70	46 406 169		45°	H	<b>VAG96171</b> ■ ■ ■ 42.00 x 8.02 x 14.06
<b>V91638</b> ■ 28.50 x 7.00 x 126.00	7 958 073		45°	ss	

<b>BT420</b> Fibre Composite	<b>DT410</b>	<b>HB5092</b> ⊗ M10x1.25x115.00mm (x10)	<b>JA757</b> ■	<b>HR363</b> ■



BT420



<b>407</b>	<b>84.00</b>	<b>Petrol</b>				
<b>835 C5.000</b>	4 Cyl.	9.5:1	1756cc	<b>66kW (90)PS</b>	<b>TD1847</b>	<b>1087</b>

<b>TB303</b> 142x18 →06/94	<b>TBK118</b> →06/94 Component No: TB303; AE1012TP				
<b>TB579</b> 97x15 Driven unit: balance shaft					







<b>BT410</b> Fibre Composite	<b>GT423</b>	<b>JA757</b> ■











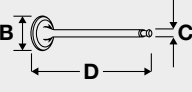



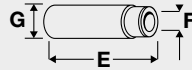



BT410

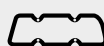

**408**  **84.00** **Petrol** 

836 A5.000 4 Cyl. 10:1 1756cc 74kW (101)PS TD4615 1084







					
<b>TB303</b> 142x18 <b>TB579</b> 97x15 Driven unit: balance shaft	<b>TBK118</b> Component No: TB303; AE1012TP				<b>FOL38</b> (x8)







	OE				
<b>V91290</b> ■ 43.50 x 8.00 x 105.70	46 406 169		45°	H	<b>VAG96171</b> ■ ■ ■ 42.00 x 8.02 x 14.06
<b>V91305</b> ■ 36.50 x 8.00 x 106.00	7 597 080		45°		



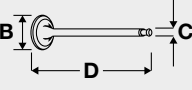



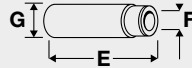

							
<b>BT440</b> Fibre Composite <b>AY500</b> Fibre Composite, 1.85mm	<b>DT449</b>		<b>HBS092</b> ⊗ M10x1.25x115.00mm (x10)				
							
<b>AY500</b>	<b>BT440</b>						

**409**  **84.00** **Petrol** 

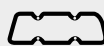

836 A5.000 4 Cyl. 1756cc 71-74kW (97-101)PS TD892 1089







					
<b>TB303</b> 142x18 Eng.→1066635 <b>TB299</b> 139x18 Eng.1066636→	<b>TBK118</b> Eng.→1066635 Component No: TB303; AE1012TP				

	OE				
<b>V91290</b> ■ 43.50 x 8.00 x 105.70	46 406 169		45°	H	<b>VAG96171</b> ■ ■ ■ 42.00 x 8.02 x 14.06
<b>V91638</b> ■ 28.50 x 7.00 x 126.00	7 958 073		45°	ss	







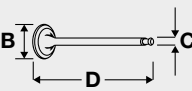
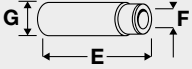

							
<b>BT440</b> Fibre Composite	<b>DT449</b>		<b>HBS092</b> ⊗ M10x1.25x115.00mm (x10)	<b>JC662</b> ■ <b>JD019</b> ■	<b>JN948</b>	<b>HR363</b> ■	<b>NA5187</b> (x2) 30.00x52.00x7.00mm ACM
							
<b>BT440</b>							

# FIAT GROUP

<b>410</b>	 <b>84.00</b>	<b>Petrol</b>	
836 A6.000	4 Cyl.	9.6:1	1756cc
			66kW (90)PS
			TD11918 <b>1090</b>



					
<b>TB303</b> 142x18	<b>TBK118</b> Component No: TB303; AE1012TP		<b>KIT</b>		<b>FOL38 (x8)</b>

	
B x C x D	E x F x G
<b>V91290</b> ■ 43.50 x 8.00 x 105.70	<b>VAG96171</b> ■ ■ ■ 42.00 x 8.02 x 14.06
<b>V91305</b> ■ 36.50 x 8.00 x 106.00	

							
<b>BR620</b> Fibre Composite			<b>HB5092</b> ☉ M10x1.25x115.00mm (x10)	<b>JA757</b> ■			<b>NA5187</b> 30.00x52.00x7.00mm ACM



BR620

<b>411</b>	 <b>84.00</b>	<b>Petrol</b>	
836 A6.000	4 Cyl.	9.6:1	1756cc
			66kW (90)PS
			TD18890 <b>1091</b>

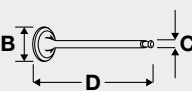
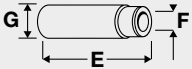
	
B x C x D	E x F x G
<b>V91290</b> ■ 43.50 x 8.00 x 105.70	<b>VAG96171</b> ■ ■ ■ 42.00 x 8.02 x 14.06
<b>V91638</b> ■ 28.50 x 7.00 x 126.00	

<b>412</b>	<b>84.00</b>	<b>Petrol</b>			
AR 64103	4 Cyl.	1995cc	106kW (144)PS	TD129	1151
AR 67101	4 Cyl.	1773cc	93-95kW (126-129)PS	TD133	1093
AR 67102	4 Cyl. 10:1	1773cc	93kW (127)PS	TD5311	1093
AR 67402	4 Cyl.	1756cc	77kW (105)PS	TD5071	1092

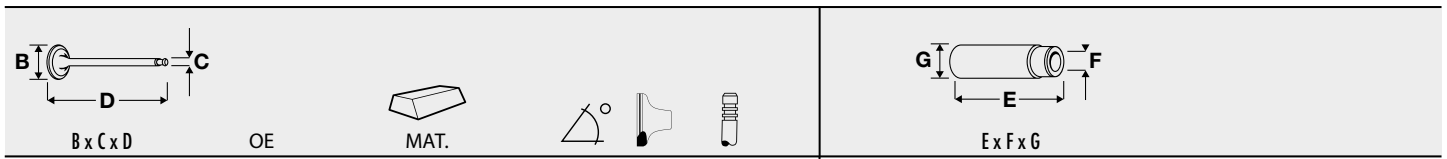

<b>V91308</b>	605 64 098		45°	<b>VAG96260B</b>	48.00 x 8.00 x 15.07
44.00 x 8.00 x 116.00		MD cr		<b>VAG96268</b>	45.00 x 8.00 x 15.07

BW410 Fibre Composite	DW410	GW410		JD235	JN940	HR363	
				JD015  (x4)			

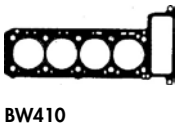

<b>413</b>	<b>84.00</b>	<b>Petrol</b>				
169 B	4 Cyl.	7.5:1	1796cc	49kW (67)PS	TD12750	1094

	DM710						

<b>414</b>	<b>84.00</b>	<b>Petrol</b>				
AR 00512	4 Cyl.	9:1	1962cc	96kW (131)PS	TD75	1097







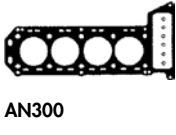



<b>TB192</b>	<b>.KIT</b>		<b>KIT</b>			





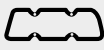





119x19						
Length: 1133.5mm						
Groove Distance: 9.525						





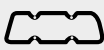

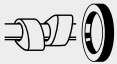



AN300 Fibre Composite	CN306			JA840		
	DC373			JA829		





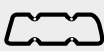











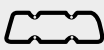





# FIAT GROUP





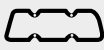





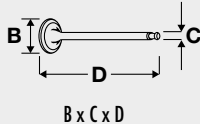

<b>415</b>	 <b>84.00</b>	<b>Petrol</b>					
AR 00515	4 Cyl.	1962cc	92-93kW (125-126)PS	<b>TD21</b>	<b>1098</b>		
							
AN300 Fibre Composite	CN306			JC497 ■ JA829 ■			
							
AN300							



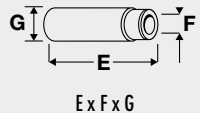



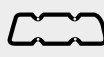



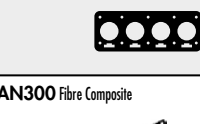

<b>416</b>	 <b>84.00</b>	<b>Petrol</b>					
AR 01544	4 Cyl.	1962cc	85kW (116)PS	<b>TD28</b>	<b>1100</b>		
							
AN300 Fibre Composite				JD018 ■ JA829 ■ (x4)	JN806 (MVQ) KV102		
							
AN300							



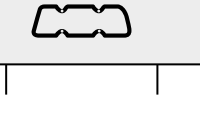



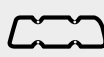



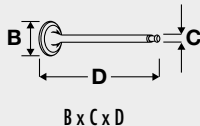

<b>417</b>	 <b>84.00</b>	<b>Petrol</b>					
AR 01588	4 Cyl.	1962cc	88kW (120)PS	<b>TD30</b>	<b>1101</b>		
							
AA5520 1.850mm	CN306 DT350			JE696	JN812	HR363 ■	
							
AA5520							

<b>418</b>	 <b>84.00</b>	<b>Petrol</b>					
AR 01590	4 Cyl.	1962cc	93kW (126)PS	<b>TD31</b>	<b>1098</b>		
							
	CN306			JA829 ■			

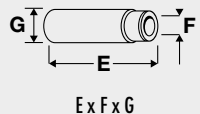
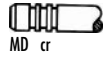
<b>419</b>	 <b>84.00</b>	<b>Petrol</b>					
AR 01623	4 Cyl.	1962cc	89-90kW (121-122)PS	<b>TD34</b>	<b>1102</b>		
							
AN300 Fibre Composite				JA840 ■ JA829 ■			
							
AN300							

<b>420</b>	 <b>84.00</b>	<b>Petrol</b>				
AR 01655	4 Cyl.	1962cc	96kW (131)PS	TD37	<b>1103</b>	
 B x C x D		OE	MAT.	  	 E x F x G	
 AN300 Fibre Composite		 CN306	 GT350	 JA840 ■ JA829 ■	 VAG92168B ■ 51.00 x 9.00 x 14.05	 HR363 ■
 AN300						

<b>421</b>	 <b>84.00</b>	<b>Petrol</b>				
AR 01713	4 Cyl.	1962cc	94-97kW (128-132)PS	TD41	<b>1098</b>	
AR 06212	4 Cyl.	9.1:1	1962cc	94-96kW (128-131)PS	TD57	<b>1103</b>
 B x C x D		OE	MAT.	  	 E x F x G	
 AN300 Fibre Composite		 CN306	 GT350	 JA829 ■	 VAG96260B ■ 48.00 x 8.00 x 15.07 VAG96268 ■ 45.00 x 8.00 x 15.07	 HR363 ■
 AN300						

<b>422</b>	 <b>84.00</b>	<b>Petrol</b>				
AR 06166	4 Cyl.	10:1	1962cc	107kW (146)PS	TD53	<b>1105</b>
AR 06224	4 Cyl.		1962cc	107-109kW (146-148)PS	TD58	<b>1106</b>
AR 06416	4 Cyl.		1995cc	102-105kW (138-143)PS	TD62	<b>1149</b>
AR 06420	4 Cyl.		1995cc	109kW (148)PS	TD63	<b>1149</b>
 B x C x D		OE	MAT.	  	 E x F x G	
<b>V91308 ■</b> 44.00 x 8.00 x 116.00		605 64 098  MD cr	45°	VAG96260B ■ 48.00 x 8.00 x 15.07 VAG96268 ■ 45.00 x 8.00 x 15.07	 HR363 ■	
 AA5520 1.850mm		 DT350	 GT350	 JD015 ■ JE696	JN812	HR363 ■
 AA5520						

# FIAT GROUP

<b>423</b>	84.00	<b>Petrol</b>				
AR 10512	4 Cyl.	10:1	1962cc	96kW (131)PS	TD5351	1107
	OE					
<b>V94732</b> ■ 44.10 x 9.00 x 104.90	105120330001		30°	H	<b>VAG92168B</b> ■ 51.00 x 9.00 x 14.05	
					<b>VAG96216B</b> ■ 54.00 x 9.01 x 14.05	

<b>424</b>	84.00	<b>Petrol</b>				
AR 10520	4 Cyl.	1962cc	97kW (132)PS	TD10270	1108	
<b>TB192</b> 119x19 →12/77 Length: 1133.5mm Groove Distance: 9.525						

AN300 Fibre Composite				<b>JA840</b> ■ <b>JA829</b> ■			

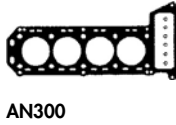



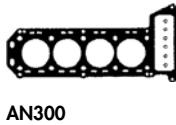







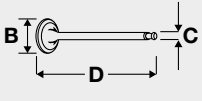



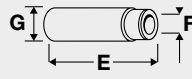







<b>425</b>	84.00	<b>Petrol</b>					
AR 10527	4 Cyl.	1962cc	96kW (131)PS	TD10127	1098		
AR 11671	4 Cyl.	10:1	1962cc	96kW (131)PS	TD70	1102	
AN300 Fibre Composite	CN306			<b>JA840</b> ■ <b>JA829</b> ■			



<b>426</b>	84.00	<b>Petrol</b>					
AR 11642	4 Cyl.	1962cc	111kW (151)PS	TD69	1104		
				<b>JA840</b> ■			











<b>427</b>	 <b>84.00</b>	<b>Petrol</b>				
<b>131 B2.000</b>	4 Cyl.	8.9:1	1995cc	<b>85-103kW (115-140)PS</b>	<b>TD900</b>	<b>1109</b>
						
B x C x D	OE	MAT.				E x F x G
<b>V91765</b> 	7 547 400	 MB cr	45°		H	<b>VAG96171</b>  42.00 x 8.02 x 14.06
43.50 x 8.00 x 105.00						
<b>V91394</b> 	5 953 041	 MD	45°	ss		
36.50 x 8.00 x 105.50						
<b>V91636</b> 	5 975 341	 MD cr	45°			
36.50 x 8.00 x 106.00						

							
<b>BK540</b> Fibre Composite	<b>DP130</b> <b>DP133</b>			<b>JM085</b>			<b>NA5187</b> 30.00x52.00x7.00mm ACM



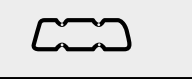









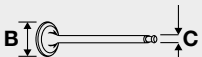



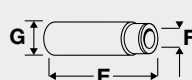





BK540

<b>428</b>	 <b>84.00</b>	<b>Petrol</b>				
<b>131 C4.000</b>	4 Cyl.	9:1	1995cc	<b>83-85kW (113-116)PS</b>	<b>TD4350</b>	<b>1110</b>
						
B x C x D	OE	MAT.				E x F x G
<b>BK540</b> 	<b>DP133</b>				<b>JM085</b>	<b>HR569</b> 



BK540

<b>429</b>	 <b>84.00</b>	<b>Petrol</b>				
<b>132 AZ2.000</b>	4 Cyl.		1995cc	<b>51kW (69)PS</b>	<b>TD13028</b>	<b>1061</b>
						
B x C x D	OE	MAT.				E x F x G
<b>V90070</b> 	4 359 309	 MD cr	45°	ss		<b>VAG96171</b>  42.00 x 8.02 x 14.06
36.10 x 8.00 x 105.79						
<b>V91714</b> 	4 469 661	 MD cr	45°			
36.50 x 8.00 x 105.79						

							
<b>BP190</b> Fibre Composite							



BP190

# FIAT GROUP

<b>430</b>	<b>84.00</b>	<b>Petrol</b>				
<b>132 C2.000</b>	4 Cyl.	8.9:1	1995cc	<b>82-84kW (112-115)PS</b>	<b>TD910</b>	<b>1112</b>
<b>132 D1.000</b>	4 Cyl.	9:1	1995cc	<b>83kW (113)PS</b>	<b>TD4354</b>	<b>1112</b>
	<b>.KIT</b>		<b>KIT</b>			
<b>TB122</b> 148x19 02/81→ <b>TB148</b> 68x15 02/81→ Driven unit: power-steering pump						

B x C x D	OE	MAT.	45°	H	VAG96171	E x F x G
<b>V91765 </b>	7 547 400		45°	H		<b>VAG96171 </b>
43.50 x 8.00 x 105.00		MB cr				42.00 x 8.02 x 14.06
<b>V91394 </b>	5 953 041	MD	45°	ss		
36.50 x 8.00 x 105.50						
<b>V91636 </b>	5 975 341	MD cr	45°			
36.50 x 8.00 x 106.00						

	DP130				JM085		

<b>431</b>	<b>84.00</b>	<b>Petrol</b>				
<b>132 C3.000</b>	4 Cyl.	9:1	1995cc	<b>88-90kW (120-122)PS</b>	<b>TD4353</b>	<b>1112</b>
	<b>.KIT</b>		<b>KIT</b>			
<b>TB122</b> 148x19 <b>TB148</b> 68x15 Driven unit: power-steering pump						

BK540 Fibre Composite	DP133				JM085		



BK540

<b>432</b>	<b>84.00</b>	<b>Petrol</b>				
<b>132 C3.031</b>	4 Cyl.	9:1	1995cc	<b>76-77kW (103-105)PS</b>	<b>TD908</b>	<b>1113</b>
					JM085	HR300

## 433

### 84.00

### Petrol



138 AR1.000	4 Cyl.	1995cc	92kW (125)PS	TD4360	1111
138 AR2.000	4 Cyl.	1995cc	96kW (130)PS	TD4361	1111

TB122 148x19					

	OE	MAT.			
B x C x D					E x F x G
V91290	46 406 169		45°	H	VAG96171
43.50 x 8.00 x 105.70		MB			42.00 x 8.02 x 14.06
V91765	7 547 400		45°	H	
43.50 x 8.00 x 105.00		MB cr			
V90070	4 359 309		45°	ss	
36.10 x 8.00 x 105.79		MD cr			
V91394	5 953 041		45°	ss	
36.50 x 8.00 x 105.50		MD			
V91636	5 975 341		45°		
36.50 x 8.00 x 106.00		MD cr			

					JM085			
--	--	--	--	--	-------	--	--	--

**434**

**84.00**

**Petrol**



154 A1.000

4 Cyl.

8:1

1995cc

66kW (90)PS

Turbocharged

TD1077

1114



**TB303**

142x18

08/86 →

**TB579**

97x15

Driven unit: balance shaft

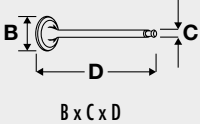

B x C x D

OE



MAT.



45°

H

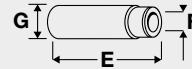

E x F x G

**VAG96171**   
42.00 x 8.02 x 14.06

**V91290**   
43.50 x 8.00 x 105.70

**V91765**   
43.50 x 8.00 x 105.00

**V90070**   
36.10 x 8.00 x 105.79

**V91394**   
36.50 x 8.00 x 105.50

**V91636**   
36.50 x 8.00 x 106.00

46 406 169

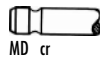
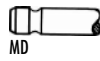
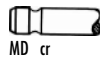
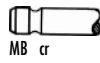
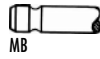

7 547 400

4 359 309

5 953 041

5 975 341

45°

45°

45°

45°

45°

ss

45°

45°

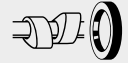
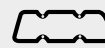

**BT510** Fibre Composite   
**BT520** Fibre Composite

**DP688**

**HBS092**   
M10x1.25x115.00mm (x10)

**JA757**

**JN643**  
**LB414**

**HR596**



















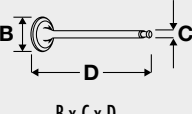



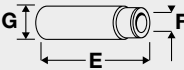

**NA5187** (x2)  
30.00x52.00x7.00mm ACM



BT510





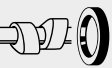









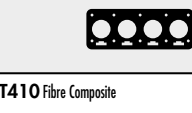

BT520

<b>435</b>  <b>84.00</b> <b>Petrol</b> 							
<b>154 A2.000</b>	<b>4 Cyl.</b> <b>8:1</b> <b>1995cc</b> <b>114kW (155)PS</b> <b>Turbo Intercooled</b> <b>TD1083</b> <b>1115</b>						
 	 						
<b>TB303</b> 142x18 <b>TB579</b> 97x15 Driven unit: balance shaft							
 $B \times C \times D$	 <b>MAT.</b>	 $45^\circ$	 <b>H</b>	 $E \times F \times G$			
<b>V91290</b> ■ ■ 46 406 169 43.50 x 8.00 x 105.70	<b>OE</b> 46 406 169	 <b>MB</b>	$45^\circ$	<b>VAG96171</b> ■ ■ ■ 42.00 x 8.02 x 14.06			
<b>V91765</b> ■ ■ 43.50 x 8.00 x 105.00	7 547 400	 <b>MB cr</b>	$45^\circ$				
<b>V90070</b> ■ 36.10 x 8.00 x 105.79	4 359 309	 <b>MD cr</b>	$45^\circ$ <b>ss</b>				
<b>V91394</b> ■ 36.50 x 8.00 x 105.50	5 953 041	 <b>MD</b>	$45^\circ$ <b>ss</b>				
<b>V91636</b> ■ 36.50 x 8.00 x 106.00	5 975 341	 <b>MD cr</b>	$45^\circ$				
							
<b>BT420</b> Fibre Composite	<b>DT420</b> →Eng.1239615		<b>HBS092</b> ☒ M10x1.25x115.00mm (x10)	<b>JC662</b> ■ <b>JD019</b> ■ 01/92→	<b>JN643</b> (x2)	<b>HR569</b> ■	



BT420

<b>436</b>  <b>84.00</b> <b>Petrol</b> 							
<b>154 C3.000</b>	<b>4 Cyl.</b> <b>9.75:1</b> <b>1995cc</b> <b>88kW (120)PS</b> <b>TD18822</b> <b>1116</b>						
 	 						
<b>TB303</b> 142x18 <b>TB579</b> 97x15 Driven unit: balance shaft							
	 <b>MAT.</b>	 $45^\circ$	 <b>H</b>	 $E \times F \times G$			
<b>BT410</b> Fibre Composite	<b>DT410</b>	 <b>GT410</b>	<b>HBS092</b> ☒ M10x1.25x115.00mm (x10)	<b>JC662</b> ■ <b>JA757</b> ■	<b>JN643</b> (x2) <b>LB414</b> ■	<b>HR363</b> ■	



BT410

BT420

## 437



84.00

Petrol



154 C3.046

4 Cyl.

9.75:1

1995cc

85kW (116)PS

TD984

1117



KIT



**TB303**

142x18

**TB579**

97x15

Driven unit: balance shaft

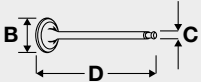

B x C x D

OE



MAT.



45°



H

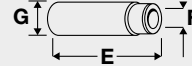

E x F x G

**V91765** ■

7 547 400



MB cr

43.50 x 8.00 x 105.00

**V91394** ■

5 953 041



MD

36.50 x 8.00 x 105.50

**V91636** ■

5 975 341



MD cr

36.50 x 8.00 x 106.00

**VAG96171** ■ ■ ■

42.00 x 8.02 x 14.06

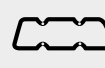
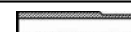

**BT420** Fibre Composite

**DT420**

→Eng.1033481

**GT440**

**HBS092** ☉

M10x1.25x115.00mm (x10)

**JC662** ■

**JA757** ■

**JN643** (x2)

**HR569** ■

**NA5187** (x2)

30.00x52.00x7.00mm ACM



**BT420**

## 438

### 84.00

### Petrol



154 C4.046

4 Cyl.

8:1

1995cc

110kW (150)PS

Turbo Intercooled

TD986

1119

<b>TB303</b> 142x18	<b>TB579</b> 97x15				
Driven unit: balance shaft					

	OE	MAT.			
B x C x D					E x F x G
<b>V91290</b>	46 406 169		45°	H	<b>VAG96171</b> 42.00 x 8.02 x 14.06
43.50 x 8.00 x 105.70					
<b>V91765</b>	7 547 400		45°	H	
43.50 x 8.00 x 105.00					
<b>V90070</b>	4 359 309		45°	ss	
36.10 x 8.00 x 105.79					
<b>V91394</b>	5 953 041		45°	ss	
36.50 x 8.00 x 105.50					
<b>V91636</b>	5 975 341		45°		
36.50 x 8.00 x 106.00					

<b>BT420</b> Fibre Composite	<b>DT420</b> →Eng.1033481	<b>DT413</b> Eng.1033482→	<b>HBS092</b>	<b>JC662</b>	<b>JA757</b>	<b>JN643</b> (x2) <b>LB414</b>	<b>HR569</b>	<b>NA5187</b> (x2) 30.00x52.00x7.00mm ACM	

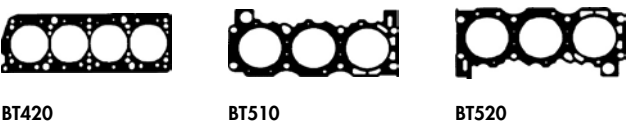

BT420      BT510      BT520

# FIAT GROUP

## 439

84.00

Petrol



154 E1.000

4 Cyl.

1995cc

101kW (137)PS

TD989

1121



**TB474**

173x18

**TB579**

97x15

Driven unit: balance shaft

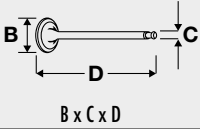

OE



MAT.



45°



ss

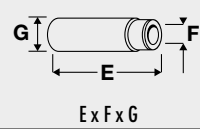

**V91935**

7 722 907

34.40 x 7.00 x 128.00

**V91638**

7 958 073

28.50 x 7.00 x 126.00

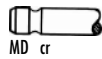
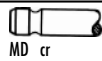

**VAG92496**

51.00 x 7.03 x 14.04

**VAG96181B**

51.30 x 7.04 x 14.05

**VAG96199**

51.30 x 7.04 x 14.08

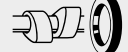
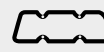

BT440 Fibre Composite

DT441

HBS093

M10x1.25x172.00mm (x10)

JD153

JD151

JN928

HR599

NA5053

30.00x42.00x7.00mm FPM



BT440

## 440

84.00

Petrol



159 A5.046

4 Cyl.

9.5:1

1995cc

80-85kW (109-116)PS

TD1011

1122



**TB303**

142x18

**TBK118**

Component No: TB303;  
AE1012TP

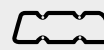

BT440 Fibre Composite

DT440  
DT446

HBS093

M10x1.25x172.00mm (x10)

HR569

NA5187 (x2)

30.00x52.00x7.00mm ACM



BT440



<b>441</b>	<b>84.00</b>	<b>Petrol</b>			
<b>159 A6.046</b>	4 Cyl.	9.5:1	1995cc	<b>83-85kW (113-116)PS</b>	<b>TD1012 1123</b>

<b>TB303</b> 142x18 <b>TB579</b> 97x15 Driven unit: balance shaft	<b>TBK118</b> Component No: TB303; AE1012TP				

B x C x D	E x F x G
<b>V91765</b>	<b>VAG96171</b>
43.50 x 8.00 x 105.00	42.00 x 8.02 x 14.06
<b>V91394</b>	
36.50 x 8.00 x 105.50	
<b>V91636</b>	
36.50 x 8.00 x 106.00	

<b>BT440</b> Fibre Composite	<b>DT446</b> <b>DT449</b>		<b>HBS093</b> M10x1.25x172.00mm (x10)	<b>JC662</b> <b>JD019</b>		<b>HR363</b>	<b>NA5187</b> 30.00x52.00x7.00mm ACM



BT440

<b>442</b>	<b>84.00</b>	<b>Petrol</b>			
<b>160 A8.046</b>	4 Cyl.	1995cc	<b>107kW (146)PS</b>	<b>TD1024 1124</b>	

<b>TB474</b> 173x18					

<b>BT410</b> Fibre Composite	<b>DT411</b> [1]		<b>HBS093</b> M10x1.25x172.00mm (x10)	<b>JD153</b> <b>JD151</b>	<b>JN928</b>	<b>HR599</b>	<b>NA5053</b> 30.00x42.00x7.00mm FPM



BT410

[1] Without crankshaft seal

[1] sans bague d'étanchéité - vilebrequin

[1] senza paraolio-albero a gomiti

[1] sin cigüeñal retén

# FIAT GROUP

## 443



84.00

Petrol



175 A1.000

4 Cyl.

8:1

1995cc

140kW (190)PS

Turbo Intercooled

TD4395

1125



**TB474**

173x18

**TB579**

97x15

Driven unit: balance shaft

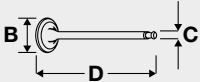

B x C x D

OE



MAT.

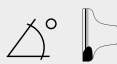

45°

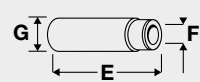

E x F x G

**V91935**

7 722 907

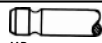

MD cr

34.40 x 7.00 x 128.00

**V91936**

7 650 916



MD cr

28.35 x 7.00 x 125.50

45°

**VAG92496**

51.00 x 7.03 x 14.04

**VAG96181B**

51.30 x 7.04 x 14.05

**VAG96199**

51.30 x 7.04 x 14.08

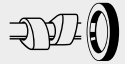
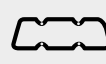

**BT440** Fibre Composite

**DT447**

**GT447**

**HBS093**

M10x1.25x172.00mm (x10)

**JD151**

**JD152**

**JN928**

**HR599**

**NA5053**

30.00x42.00x7.00mm FPM



**BT440**

## 444



84.00

Petrol



175 A4.000

4 Cyl.

8:1

1995cc

142kW (193)PS

Turbocharged

TD11827

1126



**TB474**

173x18

**TB579**

97x15

Driven unit: balance shaft

**FOL106** (x16)

Height: 24mm

**FOL145** (x16)

Height: 26mm

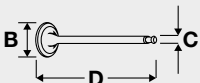

B x C x D

OE



MAT.

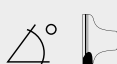

45°

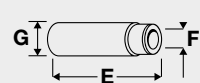

E x F x G

**V91935**

7 722 907



MD cr

34.40 x 7.00 x 128.00

**V91936**

7 650 916



MD cr

28.35 x 7.00 x 125.50

45°

**VAG92496**

51.00 x 7.03 x 14.04

**VAG96181B**

51.30 x 7.04 x 14.05

**VAG96199**

51.30 x 7.04 x 14.08

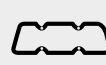













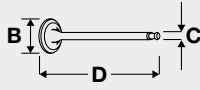



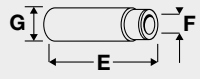







**HBS093**





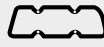





M10x1.25x172.00mm (x10)

**HR599**

**NA5053**

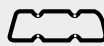
30.00x42.00x7.00mm FPM

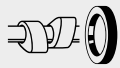
<b>445</b>		 <b>84.00</b>	<b>Petrol</b>					
<b>828 B4.000</b>	4 Cyl.	8.9:1	1995cc	<b>90kW (122)PS</b>	<b>TD4602</b>	<b>1127</b>		
 B x C x D	OE	MAT.	  	 E x F x G				
<b>V90070</b>  36.10 x 8.00 x 105.79	4 359 309	 MD cr	45° ss	<b>VAG51023B</b>  47.00 x 8.04 x 15.04				
<b>V91714</b>  36.50 x 8.00 x 105.79	4 469 661	 MD cr	45°	<b>VAG96171</b>  42.00 x 8.02 x 14.06				
								
		<b>DP133</b>			<b>JM663</b> 			

<b>446</b>		 <b>84.00</b>	<b>Petrol</b>					
<b>828 B7.000</b>	4 Cyl.	9:1	1995cc	<b>99kW (135)PS</b>	<b>TD1800</b>	<b>1078</b>		
								
<b>BK540</b> Fibre Composite								
								
<b>BK540</b>								

**447**



**84.00**

**Petrol**



831 B4.000

4 Cyl.

9.7:1

1995cc

85kW (115)PS

TD1812

1128



**TB579**  
97x15  
→07/89  
Driven unit: balance shaft  
**TB303**  
142x18  
11/86→07/89

**FOL38 (x8)**

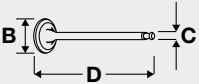

B x C x D

OE



MAT.

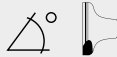

45°



H

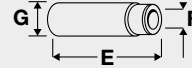

E x F x G

**V91290** ■  
43.50 x 8.00 x 105.70

46 406 169

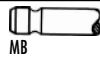

MB

45°

H

**V91765** ■  
43.50 x 8.00 x 105.00

7 547 400

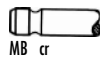

MB cr

45°

H

**V90070** ■  
36.10 x 8.00 x 105.79

4 359 309

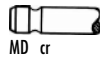

MD cr

45°

ss

**V91394** ■  
36.50 x 8.00 x 105.50

5 953 041

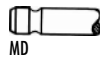

MD

45°

ss

**V91636** ■  
36.50 x 8.00 x 106.00

5 975 341

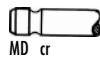

MD cr

45°

**VAG96171** ■ ■ ■  
42.00 x 8.02 x 14.06

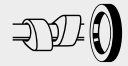
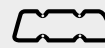

BT440 Fibre Composite

DT411 [1]

GT423





**BT440**







[1] Without crankshaft seal

[1] sans bague d'étanchéité - vilebrequin

[1] senza paraolio-albero a gomiti

[1] sin cigüeñal retén

<b>448</b>	 <b>84.00</b>	<b>Petrol</b>					
<b>831 B5.000</b>	4 Cyl.	8:1	1995cc	<b>122kW (166)PS</b>	<b>Turbo Intercooled</b>	<b>TD1823</b>	<b>1129</b>
<b>835 A7.046</b>	4 Cyl.	8:1	1995cc	<b>124kW (169)PS</b>	<b>Turbocharged</b>	<b>TD1850</b>	<b>1129</b>

					
<b>TB303</b> 142x18 <b>TB579</b> 97x15 Driven unit: balance shaft	<b>TBK118</b> Component No: TB303; AE1012TP				

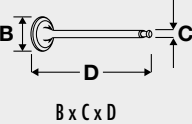
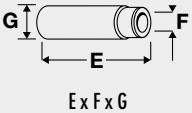
	
B x C x D	Ex F x G

<b>V91290</b> 	46 406 169		45°		<b>VAG96171</b> 	
43.50 x 8.00 x 105.70		MB			42.00 x 8.02 x 14.06	
<b>V91394</b> 	5 953 041		45°	ss		
36.50 x 8.00 x 105.50		MD				







							
---	---	---	---	---	---	---	---

<b>BT410</b> Fibre Composite		<b>GT423</b>		<b>JA757</b> 			
------------------------------	--	--------------	--	--	--	--	--





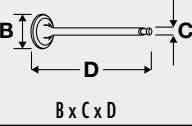
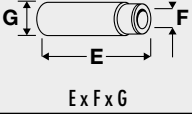

							
--	--	--	--	--	--	--	--

<b>449</b>	 <b>84.00</b>	<b>Petrol</b>	
------------	--	---------------	---

<b>831 C5.000</b>	4 Cyl.	8:1	1995cc	<b>133kW (181)PS</b>	<b>Turbocharged</b>	<b>TD1821</b>	<b>1130</b>
-------------------	--------	-----	--------	----------------------	---------------------	---------------	-------------

					
<b>TB303</b> 142x18 <b>TB579</b> 97x15 Driven unit: balance shaft	<b>TBK118</b> Component No: TB303; AE1012TP				

	
B x C x D	Ex F x G

<b>V91290</b> 	46 406 169		45°		<b>VAG96171</b> 	
43.50 x 8.00 x 105.70		MB			42.00 x 8.02 x 14.06	
<b>V91394</b> 	5 953 041		45°	ss		
36.50 x 8.00 x 105.50		MD				

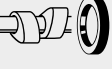
							
---	---	---	---	---	---	---	---

	<b>DT423</b>	<b>GT423</b>	<b>HBS092</b> 				
--	--------------	--------------	---	--	--	--	--

			M10x1.25x115.00mm (x10)				
--	--	--	-------------------------	--	--	--	--

# FIAT GROUP

<b>450</b>	<b>84.00</b>	<b>Petrol</b>					
<b>831 C5.046</b>	4 Cyl.	8:1	1995cc	<b>130kW (177)PS</b>	<b>Turbocharged</b>	<b>TD1822</b>	<b>1131</b>
<b>TB579</b> 97x15 →12/91 Driven unit: balance shaft <b>TB474</b> 173x18							

B x C x D	OE	MAT.			H	E x F x G
<b>V91290</b> ■	46 406 169		45°			<b>VAG96171</b> ■ ■ ■
43.50 x 8.00 x 105.70		MB				42.00 x 8.02 x 14.06
<b>V91394</b> ■	5 953 041		45°	ss		
36.50 x 8.00 x 105.50		MD				

<b>BT420</b> Fibre Composite	<b>DT423</b>	<b>GT423</b>	<b>HBS092</b> ☒				
			M10x1.25x115.00mm (x10)				



BT420

<b>451</b>	<b>84.00</b>	<b>Petrol</b>					
<b>831 D5.000</b>	4 Cyl.	8:1	1995cc	<b>144kW (196)PS</b>	<b>Turbocharged</b>	<b>TD1825</b>	<b>1132</b>
<b>TB579</b> 97x15 01/91→ Driven unit: balance shaft <b>TB394</b> 145x18 Eng.→1039306 <b>TB474</b> 173x18 Eng.1039307→							







B x C x D	OE	MAT.				E x F x G
<b>V91935</b> ■	7 722 907		45°			<b>VAG92496</b> ■ ■ ■
34.40 x 7.00 x 128.00		MD cr				51.00 x 7.03 x 14.04
<b>V91936</b> ■	7 650 916		45°			<b>VAG96181B</b> ■ ■ ■
28.35 x 7.00 x 125.50		MD cr				51.30 x 7.04 x 14.05
						<b>VAG96199</b> ■ ■ ■
						51.30 x 7.04 x 14.08











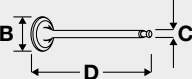

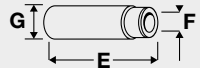

			<b>HBS093</b> ☒	<b>JD5997</b> ■		<b>HR599</b> ■	<b>NA5053</b>
			M10x1.25x172.00mm (x10)				30.00x42.00x7.00mm FPM











## 452

 **84.00**
**Petrol**

<b>831 E5.000</b>	4 Cyl.	8:1	1995cc	<b>155kW (211)PS</b>	<b>Turbocharged</b>	<b>TD1827</b>	<b>1125</b>
<b>831 E5.046</b>	4 Cyl.	8:1	1995cc	<b>155kW (211)PS</b>	<b>Turbocharged</b>	<b>TD1826</b>	<b>1125</b>

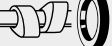
					
<b>TB474</b> 173x18			<b>KIT</b>		<b>FOL106</b> (x16) Height: 24mm
<b>TB579</b> 97x15					<b>FOL145</b> (x16) Height: 26mm
Driven unit: balance shaft					

				
B x C x D	OE	MAT.	45°	E x F x G
<b>V91935</b> 	7 722 907	 MD cr	45°	<b>VAG92496</b>  
34.40 x 7.00 x 128.00				51.00 x 7.03 x 14.04
<b>V91936</b> 	7 650 916	 MD cr	45°	<b>VAG96181B</b>  
28.35 x 7.00 x 125.50				51.30 x 7.04 x 14.05
				<b>VAG96199</b>  
				51.30 x 7.04 x 14.08

							
<b>BT440</b> Fibre Composite	<b>DT447</b>	<b>GT447</b>	<b>HBS093</b>  M10x1.25x172.00mm (x10)	<b>JD151</b> <b>JD5997</b> 	<b>JN928</b>	<b>HR599</b> 	<b>NA5053</b> 30.00x42.00x7.00mm FPM

**BT440**

**453**

 **84.00**









**Petrol**

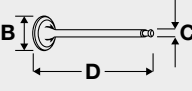

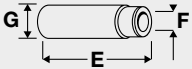
**834 B.000**      4 Cyl.      9.7:1      1995cc      **88kW (120)PS**      **TD1084**      **1133**



**TB303**  
142x18  
**TB579**  
97x15  
Driven unit: balance shaft

	OE	MAT.			
B x C x D					E x F x G
<b>V91290</b> ■	46 406 169	 MB	45°	H	<b>VAG96171</b> ■ ■ ■ 42.00 x 8.02 x 14.06 
43.50 x 8.00 x 105.70					
<b>V91765</b> ■	7 547 400	 MB cr	45°	H	
43.50 x 8.00 x 105.00					
<b>V90070</b> ■	4 359 309	 MD cr	45°	ss	
36.10 x 8.00 x 105.79					
<b>V91394</b> ■	5 953 041	 MD	45°	ss	
36.50 x 8.00 x 105.50					
<b>V91636</b> ■	5 975 341	 MD cr	45°		
36.50 x 8.00 x 106.00					

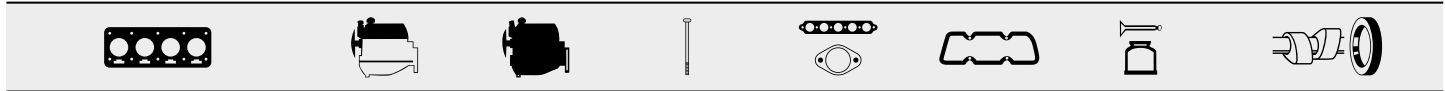

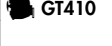
<b>BT410</b> Fibre Composite	<b>DT410</b>	 <b>GT410</b>	<b>HBS092</b> ☒ M10x1.25x115.00mm (x10)	<b>JC662</b> ■ <b>JA757</b> ■	<b>JN643</b> (x2) <b>LB414</b> ■	<b>HR363</b> ■
<b>BT420</b> Fibre Composite	<b>DT413</b>					



**BT410**



**BT420**



## 454



84.00

Petrol



834 B.000

4 Cyl.

9.8:1

1995cc

88kW (120)PS

TD1833

1134

<b>TB303</b> 142x18 <b>TB579</b> 97x15 Driven unit: balance shaft					<b>FOL104 (x8) [6]</b>
[6] Mechanical	[6] Mécanique	[6] Meccanico	[6] Mecánico		

	OE	MAT.			
B x C x D					E x F x G
<b>V91290</b>	46 406 169		45°	H	<b>VAG96171</b>
43.50 x 8.00 x 105.70		MB			
<b>V91765</b>	7 547 400		45°	H	
43.50 x 8.00 x 105.00		MB cr			
<b>V90070</b>	4 359 309		45°	ss	
36.10 x 8.00 x 105.79		MD cr			
<b>V91394</b>	5 953 041		45°	ss	
36.50 x 8.00 x 105.50		MD			
<b>V91636</b>	5 975 341		45°		
36.50 x 8.00 x 106.00		MD cr			

	DT413						

## 455

 84.00











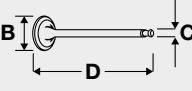

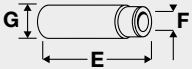

Petrol





834 B.048      4 Cyl.      9.7:1      1995cc      83kW (113)PS      TD1085      1136

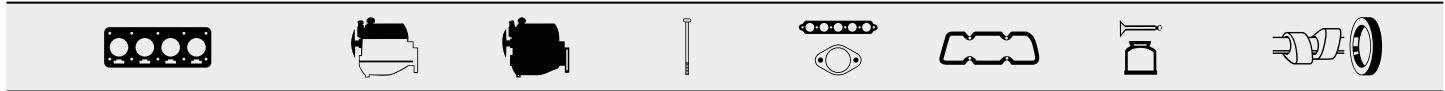

**TB303**  
142x18  
**TB579**  
97x15  
Driven unit: balance shaft

	OE	MAT.			
B x C x D					E x F x G
<b>V91290</b> 	46 406 169		45°	H	<b>VAG96171</b>  42.00 x 8.02 x 14.06
43.50 x 8.00 x 105.70		MB			
<b>V91765</b> 	7 547 400		45°	H	
43.50 x 8.00 x 105.00		MB cr			
<b>V90070</b> 	4 359 309		45°	ss	
36.10 x 8.00 x 105.79		MD cr			
<b>V91394</b> 	5 953 041		45°	ss	
36.50 x 8.00 x 105.50		MD			
<b>V91636</b> 	5 975 341		45°		
36.50 x 8.00 x 106.00		MD cr			



<b>BT420</b> Fibre Composite	<b>DT420</b>	<b>HBS092</b> 	<b>HR363</b> 
<b>BT410</b> Fibre Composite Eng.1033482 →	→Eng.1033481 <b>DT413</b> Eng.1033492 →	M10x1.25x115.00mm (x10)	



BT410



BT420

## 456

 **84.00**

**Petrol**



834 B.048

4 Cyl.







9.8:1











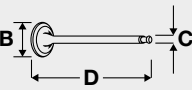



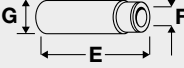

1995cc









83-85kW (112-113)PS

TD1829

1135

					
<b>TB303</b> 142x18 <b>TB579</b> 97x15 Driven unit: balance shaft					<b>FOL104 (x8) [6]</b>
[6] Mechanical	[6] Mécanique	[6] Meccanico	[6] Mecánico		

	OE	MAT.				
B x C x D						E x F x G
<b>V91290</b> 	46 406 169	 MB	45°		H	<b>VAG96171</b>  42.00 x 8.02 x 14.06 
43.50 x 8.00 x 105.70						
<b>V91765</b> 	7 547 400	 MB cr	45°		H	
43.50 x 8.00 x 105.00						
<b>V90070</b> 	4 359 309	 MD cr	45°	ss		
36.10 x 8.00 x 105.79						
<b>V91394</b> 	5 953 041	 MD	45°	ss		
36.50 x 8.00 x 105.50						
<b>V91636</b> 	5 975 341	 MD cr	45°			
36.50 x 8.00 x 106.00						

							
			<b>HBS092</b>  M10x1.25x115.00mm (x10)				

## 457

 84.00











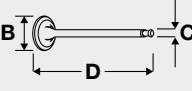

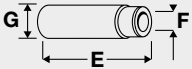

Petrol







834 B.146      4 Cyl.      9.7:1      1995cc      85kW (116)PS      TD11707      1137

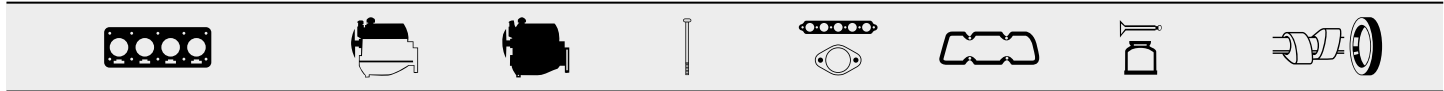

**TB303**  
142x18  
**TB579**  
97x15  
Driven unit: balance shaft

	OE	MAT.			
B x C x D					E x F x G
<b>V91290</b> 	46 406 169		45°	H	<b>VAG96171</b>  42.00 x 8.02 x 14.06
43.50 x 8.00 x 105.70		MB			
<b>V91765</b> 	7 547 400		45°	H	
43.50 x 8.00 x 105.00		MB cr			
<b>V90070</b> 	4 359 309		45°	ss	
36.10 x 8.00 x 105.79		MD cr			
<b>V91394</b> 	5 953 041		45°	ss	
36.50 x 8.00 x 105.50		MD			
<b>V91636</b> 	5 975 341		45°		
36.50 x 8.00 x 106.00		MD cr			



<b>BT420</b> Fibre Composite	<b>DT420</b> →Eng.1033481	<b>GT440</b>	<b>HBS092</b>  M10x1.25x115.00mm (x10)	<b>JC662</b>  <b>JA757</b> 	<b>JN643</b> (x2) <b>JN948</b>	<b>HR363</b> 	<b>NA5187</b> (x2) 30.00x52.00x7.00mm ACM
------------------------------	------------------------------	--------------	--	--	-----------------------------------	--	--



BT420

<b>458</b>	<b>84.00</b>	<b>Petrol</b>	
834 B.146	4 Cyl.	9.8:1	1995cc
			85kW (116)PS
			TD1818 <b>1135</b>

<b>TB303</b> 142x18 <b>TB579</b> 97x15 Driven unit: balance shaft	<b>TBK118</b> Component No: TB303; AE1012TP				

	OE	MAT.			
B x C x D					E x F x G
<b>V91290</b>	46 406 169		45°	H	<b>VAG96171</b> 42.00 x 8.02 x 14.06
43.50 x 8.00 x 105.70		MB			
<b>V91765</b>	7 547 400		45°	H	
43.50 x 8.00 x 105.00		MB cr			
<b>V90070</b>	4 359 309		45°	ss	
36.10 x 8.00 x 105.79		MD cr			
<b>V91394</b>	5 953 041		45°	ss	
36.50 x 8.00 x 105.50		MD			
<b>V91636</b>	5 975 341		45°		
36.50 x 8.00 x 106.00		MD cr			

	DT413		<b>HBS092</b>					
			M10x1.25x115.00mm (x10)					

<b>459</b>	<b>84.00</b>	<b>Petrol</b>	
834 B1.000	4 Cyl.	9.5:1	1995cc
			86kW (117)PS
			TD1830 <b>1135</b>

<b>TB579</b> 97x15 01/89→12/90 Driven unit: balance shaft					

	OE	MAT.			
B x C x D					E x F x G
<b>V91290</b>	46 406 169		45°	H	<b>VAG96171</b> 42.00 x 8.02 x 14.06
43.50 x 8.00 x 105.70		MB			
<b>V91765</b>	7 547 400		45°	H	
43.50 x 8.00 x 105.00		MB cr			
<b>V90070</b>	4 359 309		45°	ss	
36.10 x 8.00 x 105.79		MD cr			
<b>V91394</b>	5 953 041		45°	ss	
36.50 x 8.00 x 105.50		MD			
<b>V91636</b>	5 975 341		45°		
36.50 x 8.00 x 106.00		MD cr			

			<b>HBS092</b>					
			M10x1.25x115.00mm (x10)					

# FIAT GROUP

<b>460</b>	<b>84.00</b>	<b>Petrol</b>						
<b>834 B2.000</b>	4 Cyl.	1995cc	<b>108kW (147)PS</b>	<b>TD14549</b>	<b>1138</b>			

<b>TB303</b> 142x18 <b>TB579</b> 97x15 Driven unit: balance shaft	<b>TBK118</b> Component No: TB303; AE1012TP				

B x C x D	OE	MAT.	45°	45°	E x F x G
<b>V91935</b> ■	7 722 907		45°	<b>VAG92496</b> ■ ■ ■	
34.40 x 7.00 x 128.00		MD cr		51.00 x 7.03 x 14.04	
<b>V91936</b> ■	7 650 916		45°	<b>VAG96181B</b> ■ ■ ■	
28.35 x 7.00 x 125.50		MD cr		51.30 x 7.04 x 14.05	
				<b>VAG96199</b> ■ ■ ■	
				51.30 x 7.04 x 14.08	

<b>BT440</b> Fibre Composite	<b>DT441</b>	<b>GT441</b>	<b>HBS093</b> ☒ M10x1.25x172.00mm (x10)	<b>JD153</b> ■ <b>JD151</b> <b>JD5997</b> ■	<b>JN928</b>	<b>HR599</b> ■	<b>NA5053</b> 30.00x42.00x7.00mm FPM





BT440

<b>461</b>	<b>84.00</b>	<b>Petrol</b>						
<b>834 B2.246</b>	4 Cyl.	8:1	1995cc	<b>104kW (141)PS</b>	<b>Turbocharged</b>	<b>TD1832</b>	<b>1139</b>	







<b>TB394</b> 145x18 →10/89 <b>TB474</b> 173x18 11/89→ <b>TB579</b> 97x15 Driven unit: balance shaft					









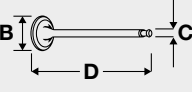

B x C x D	OE	MAT.	45°	45°	E x F x G
<b>V91935</b> ■	7 722 907		45°	<b>VAG92496</b> ■ ■ ■	
34.40 x 7.00 x 128.00		MD cr		51.00 x 7.03 x 14.04	
<b>V91936</b> ■	7 650 916		45°	<b>VAG96181B</b> ■ ■ ■	
28.35 x 7.00 x 125.50		MD cr		51.30 x 7.04 x 14.05	
				<b>VAG96199</b> ■ ■ ■	
				51.30 x 7.04 x 14.08	



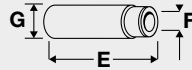



	<b>DT441</b>		<b>HBS093</b> ☒ M10x1.25x172.00mm (x10)	<b>JD5997</b> ■		<b>HR599</b> ■	<b>NA5053</b> 30.00x42.00x7.00mm FPM

**462**  **84.00** **Petrol** 

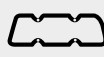

**834 C.000** 4 Cyl. 8:1 1995cc **122kW (166)PS** **Turbo Intercooled** **TD1834** **1140**

					
<b>TB303</b> 142x18 <b>TB579</b> 97x15 Driven unit: balance shaft					

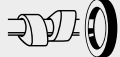

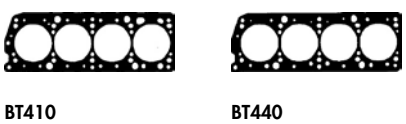



					
B x C x D	OE	MAT.	45°	H	E x F x G
<b>V91290</b> 	46 406 169		45°	H	<b>VAG96171</b> 
43.50 x 8.00 x 105.70		MB			42.00 x 8.02 x 14.06
<b>V91394</b> 	5 953 041		45°	ss	
36.50 x 8.00 x 105.50		MD			









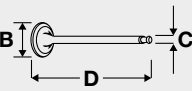

							
<b>BT440</b> Fibre Composite	<b>BT410</b> Fibre Composite Eng.1033482 →	<b>DT420</b> →Eng.1033481					
		<b>DT413</b> Eng.1033482 →					

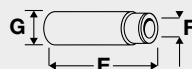

**463**  **84.00** **Petrol** 

**834 C.146** 4 Cyl. 8:1 1995cc **110kW (150)PS** **Turbo Intercooled** **TD1837** **1140**

					
<b>TB303</b> 142x18 <b>TB579</b> 97x15 Driven unit: balance shaft	<b>TBK118</b> Component No: TB303; AE1012TP				

					
B x C x D	OE	MAT.	45°	H	E x F x G
<b>V91290</b> 	46 406 169		45°	H	<b>VAG96171</b> 
43.50 x 8.00 x 105.70		MB			42.00 x 8.02 x 14.06
<b>V91394</b> 	5 953 041		45°	ss	
36.50 x 8.00 x 105.50		MD			

**464**

 **84.00**









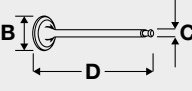

**Petrol**

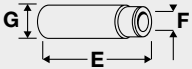

834 C.146      4 Cyl.      8:1      1995cc      110-112kW (150-152)PS      Turbo Intercooled      TD1064      **1141**



**TB303**  
142x18  
**TB579**  
97x15  
Driven unit: balance shaft

	OE	MAT.				
B x C x D						E x F x G
<b>V91290</b> ■	46 406 169		45°		H	<b>VAG96171</b> ■ ■ ■ 42.00 x 8.02 x 14.06 
43.50 x 8.00 x 105.70		MB				
<b>V91765</b> ■	7 547 400		45°		H	
43.50 x 8.00 x 105.00		MB cr				
<b>V90070</b> ■	4 359 309		45°	ss		
36.10 x 8.00 x 105.79		MD cr				
<b>V91394</b> ■	5 953 041		45°	ss		
36.50 x 8.00 x 105.50		MD				
<b>V91636</b> ■	5 975 341		45°			
36.50 x 8.00 x 106.00		MD cr				

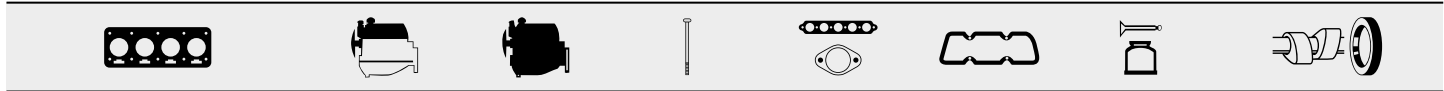

<b>BT420</b> Fibre Composite	<b>DT420</b> →Eng.1033481 <b>DT413</b> Eng.1033482→	<b>HBS092</b> ☒ M10x1.25x115.00mm (x10)	<b>JC662</b> ■ <b>JA757</b> ■	<b>JN643</b> (x2) <b>JN948</b> <b>LB414</b> ■	<b>HR363</b> ■	<b>NA5187</b> (x2) 30.00x52.00x7.00mm ACM
------------------------------	--	--	----------------------------------	---	----------------	--



**BT420**



<b>465</b>	<b>84.00</b>	<b>Petrol</b>					
<b>834 C1.000</b>	4 Cyl.	8:1	1995cc	<b>133kW (181)PS</b>	<b>Turbo Intercooled</b>	<b>TD1835</b>	<b>1126</b>

	<b>KIT</b>		<b>KIT</b>				
<b>TB394</b> 145x18 →10/89							<b>FOL104 (x16) [6]</b>
<b>TB474</b> 173x18 11/89→							
<b>TB579</b> 97x15							
<b>Driven unit: balance shaft</b>							
[6] Mechanical	[6] Mécanique	[6] Meccanico	[6] Mecánico				

B x C x D	OE	MAT.	E x F x G
<b>V91935</b>	7 722 907	45°	<b>VAG92496</b>
34.40 x 7.00 x 128.00		MD cr	51.00 x 7.03 x 14.04
<b>V91638</b>	7 958 073	45° ss	<b>VAG96181B</b>
28.50 x 7.00 x 126.00		MD cr	51.30 x 7.04 x 14.05
			<b>VAG96199</b>
			51.30 x 7.04 x 14.08

<b>BT440</b> Fibre Composite	<b>DT442</b>	<b>GT442</b>	<b>HBS093</b>	<b>JD153</b>	<b>JN928</b>	<b>HR599</b>	<b>NA5053</b>
			M10x1.25x172.00mm (x10)	<b>JD151</b>			30.00x42.00x7.00mm FPM



**BT440**

# FIAT GROUP

<b>466</b>	<b>84.00</b>	<b>Petrol</b>					
<b>834 C1.246</b>	4 Cyl.	8:1	1995cc	<b>130kW (177)PS</b>	<b>Turbo Intercooled</b>	<b>TD1836</b>	<b>1124</b>
<b>TB303</b> 142x18 <b>TB579</b> 97x15 Driven unit: balance shaft	<b>TBK118</b> Component No: TB303; AE1012TP						<b>FOL104 (x16) [6]</b>
[6] Mechanical	[6] Mécanique	[6] Meccanico	[6] Mecánico				
	OE	MAT.					
<b>V91935</b> ■ 34.40 x 7.00 x 128.00	7 722 907	 MD cr	45°		<b>VAG92496</b> ■ ■ ■ 51.00 x 7.03 x 14.04		
<b>V91638</b> ■ 28.50 x 7.00 x 126.00	7 958 073	 MD cr	45° ss		<b>VAG96181B</b> ■ ■ ■ 51.30 x 7.04 x 14.05		
					<b>VAG96199</b> ■ ■ ■ 51.30 x 7.04 x 14.08		
				<b>JD5997</b> ■		<b>HR599</b> ■	<b>NA5053</b> 30.00x42.00x7.00mm FPM

<b>467</b>	<b>84.00</b>	<b>Petrol</b>					
<b>834 F1.000</b>	4 Cyl.	1995cc	<b>110-112kW (150-152)PS</b>	<b>TD1831</b>	<b>1121</b>		
<b>TB474</b> 173x18 <b>TB579</b> 97x15 Driven unit: balance shaft							
	OE	MAT.					
<b>V91935</b> ■ 34.40 x 7.00 x 128.00	7 722 907	 MD cr	45°		<b>VAG92496</b> ■ ■ ■ 51.00 x 7.03 x 14.04		
<b>V91638</b> ■ 28.50 x 7.00 x 126.00	7 958 073	 MD cr	45° ss		<b>VAG96181B</b> ■ ■ ■ 51.30 x 7.04 x 14.05		
					<b>VAG96199</b> ■ ■ ■ 51.30 x 7.04 x 14.08		
<b>BT440</b> Fibre Composite	<b>DT443</b> <b>DT448</b>		<b>HBS093</b> ☒ M10x1.25x172.00mm (x10)	<b>JD153</b> ■ <b>JD151</b> <b>JD5997</b> ■	<b>JN928</b>	<b>HR599</b> ■	<b>NA5053</b> 30.00x42.00x7.00mm FPM



BT440

<b>468</b>	<b>84.00</b>	<b>Petrol</b>	
<b>834 F2.000</b>	4 Cyl.	1995cc	<b>148kW (202)PS</b>
			<b>Turbo Intercooled</b>
			<b>TD1840 1126</b>
<b>TB474</b> 173x18			<b>FOL38 (x16)</b>
<b>TB579</b> 97x15			
Driven unit: balance shaft			

B x C x D	E x F x G
OE	
	<b>VAG96181B</b>
	51.30 x 7.04 x 14.05
	<b>VAG96199</b>
	51.30 x 7.04 x 14.08

<b>BT440</b> Fibre Composite	<b>DT442</b>		<b>HBS093</b>	<b>JD5997</b>		<b>HR599</b>	<b>NA5053</b>
			M10x1.25x172.00mm (x10)				30.00x42.00x7.00mm FPM



BT440

<b>469</b>	<b>84.00</b>	<b>Petrol</b>	
<b>835 A5.000</b>	4 Cyl.	9.3:1	<b>1995cc</b>
			<b>86kW (117)PS</b>
			<b>TD14589 1142</b>
<b>TB303</b> 142x18	<b>TBK118</b> Component No: TB303; AE1012TP		
Driven unit: balance shaft			
<b>BT440</b> Fibre Composite	<b>DT440</b>	<b>GT440</b>	<b>HBS092</b>
			M10x1.25x115.00mm (x10)
			<b>JC662</b>
			<b>JA757</b>
			<b>HR363</b>
			<b>NA5187</b>
			30.00x52.00x7.00mm ACM



BT440

# FIAT GROUP

<b>470</b>	<b>84.00</b>	<b>Petrol</b>				
<b>835 A5.046</b>	4 Cyl.	9.3:1	1995cc	<b>82-83kW (112-113)PS</b>	<b>TD1848</b>	<b>1143</b>
<b>TB303</b> 142x18 →08/97 <b>TB579</b> 97x15 Driven unit: balance shaft	<b>TBK118</b> →08/97 Component No: TB303; AE1012TP					

B x C x D	E x F x G
<b>V91290</b> ■ 43.50 x 8.00 x 105.70	<b>VAG96171</b> ■ ■ ■ 42.00 x 8.02 x 14.06
<b>V91394</b> ■ 36.50 x 8.00 x 105.50	
OE: 46 406 169	
5 953 041	
MAT. MB MD	
45°	
45° ss	
H	

<b>BT440</b> Fibre Composite	<b>DT446</b>	<b>GT446</b> [1]	<b>HBS092</b> ☒ M10x1.25x115.00mm (x10)				<b>NPO68</b> 55.00x70.00x8.00mm FPM







**BT440**  
 [1] Without crankshaft seal      [1] sans bague d'étanchéité - vilebrequin      [1] senza paraolio-albero a gomiti      [1] sin cigüeñal retén

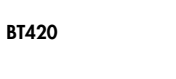









<b>471</b>	<b>84.00</b>	<b>Petrol</b>					
<b>835 A7.000</b>	4 Cyl.	8:1	1995cc	<b>121kW (165)PS</b>	<b>Turbo Intercooled</b>	<b>TD1849</b>	<b>1129</b>
<b>TB303</b> 142x18 <b>TB579</b> 97x15 01/91→ Driven unit: balance shaft	<b>TBK118</b> Component No: TB303; AE1012TP						

B x C x D	E x F x G
<b>V91290</b> ■ 43.50 x 8.00 x 105.70	<b>VAG96171</b> ■ ■ ■ 42.00 x 8.02 x 14.06
<b>V91394</b> ■ 36.50 x 8.00 x 105.50	
OE: 46 406 169	
5 953 041	
MAT. MB MD	
45°	
45° ss	
H	







**BT420**  
 [1] Without crankshaft seal      [1] sans bague d'étanchéité - vilebrequin      [1] senza paraolio-albero a gomiti      [1] sin cigüeñal retén









<b>472</b>  <b>84.00</b> <b>Petrol</b> 	
<b>835 A8.000</b>	<b>4 Cyl.</b> <b>1995cc</b> <b>130-132kW (177-180)PS</b> <b>Turbocharged</b> <b>TD14588</b> <b>1144</b>
	 <b>.KIT</b>
<b>TB303</b> 142x18 <b>TB579</b> 97x15 01/91 → Driven unit: balance shaft	<b>TBK118</b> Component No: TB303; AE1012TP

							
<b>BT240</b> Fibre Composite, 1.950mm, 2 Notches	<b>DT423</b>	<b>GT423</b>	<b>HBS092</b>  M10x1.25x115.00mm (x10)	<b>JC662</b>  <b>JD019</b> 	<b>JN643</b>		<b>NA5187</b> 30.00x52.00x7.00mm ACM



BT240

<b>473</b>  <b>84.00</b> <b>Petrol</b> 	
<b>835 A8.046</b>	<b>4 Cyl.</b> <b>1995cc</b> <b>119kW (162)PS</b> <b>Turbocharged</b> <b>TD1852</b> <b>1145</b>
	 <b>.KIT</b>
<b>TB303</b> 142x18 →06/94 <b>TB579</b> 97x15 Driven unit: balance shaft	<b>TBK118</b> →06/94 Component No: TB303; AE1012TP

							
<b>BT440</b> Fibre Composite	<b>DT440</b>		<b>HBS092</b>  M10x1.25x115.00mm (x10)				



BT440

**474**



**84.00**

**Petrol**



836 A2.000

4 Cyl.

10:1

1995cc

137kW (186)PS

Turbo Intercooled

TD5435

1125



**TB474**

173x18

**TB579**

97x15

Driven unit: balance shaft

**FOL106** (x16)

Height: 24mm

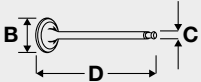

B x C x D

OE



MAT.



45°



**V91935** ■

7 722 907

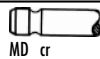

MD cr

34.40 x 7.00 x 128.00

**V91936** ■

7 650 916

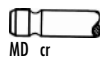

MD cr

28.35 x 7.00 x 125.50

45°

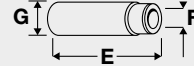

E x F x G

**VAG92496** ■ ■ ■

51.00 x 7.03 x 14.04

**VAG96181B** ■ ■ ■

51.30 x 7.04 x 14.05

**VAG96199** ■ ■ ■

51.30 x 7.04 x 14.08

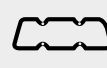

**BT440** Fibre Composite

**DT447**

**GT447**

**HBS093** ☒

M10x1.25x172.00mm (x10)

**JD151**

**JD152** ■

**JN928**

**HR599** ■

**NA5053**

30.00x42.00x7.00mm FPM



**BT440**

**475**

 **84.00**

**Petrol**



836 A3.000

4 Cyl.







10:1

1995cc





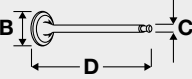
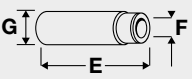

102-108kW (139-147)PS

TD4614

1121

					
<b>TB474</b> 173x18 →08/98 <b>TB579</b> 97x15 Driven unit: balance shaft					

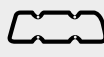
		
B x C x D	OE	Ex F x G
<b>V91935</b> ■	7 722 907	<b>VAG92496</b> ■ ■ ■
34.40 x 7.00 x 128.00		51.00 x 7.03 x 14.04
<b>V91638</b> ■	7 958 073	<b>VAG961818</b> ■ ■ ■
28.50 x 7.00 x 126.00		51.30 x 7.04 x 14.05
		<b>VAG96199</b> ■ ■ ■
		51.30 x 7.04 x 14.08

							
<b>BT440</b> Fibre Composite	<b>DT443</b>		<b>HBS093</b> ☒ M10x1.25x172.00mm (x10)	<b>JD153</b> ■ <b>JD151</b> <b>JD5997</b> ■	<b>JN928</b>	<b>HR599</b> ■	<b>NA5053</b> 30.00x42.00x7.00mm FPM



BT440

# FIAT GROUP

<b>476</b>	<b>84.00</b>	<b>Petrol</b>				
<b>836 A3.000</b>	4 Cyl.	10.5:1	1995cc	<b>102kW (139)PS</b>	<b>TD1071</b>	<b>1121</b>
	<b>KIT</b>		<b>KIT</b>			
<b>TB474</b> 173x18						<b>FOL104 (x16) [6]</b>
<b>TB579</b> 97x15						
Driven unit: balance shaft						
[6] Mechanical	[6] Mécanique	[6] Meccanico	[6] Mecánico			

B x C x D	E x F x G
OE	
<b>V91935</b> ■	<b>VAG92496</b> ■ ■ ■
34.40 x 7.00 x 128.00	51.00 x 7.03 x 14.04
<b>V91638</b> ■ ■	<b>VAG96181B</b> ■ ■ ■
28.50 x 7.00 x 126.00	51.30 x 7.04 x 14.05
	<b>VAG96199</b> ■ ■ ■
	51.30 x 7.04 x 14.08

<b>BT440</b> Fibre Composite	<b>DT443</b> <b>DT448</b>		<b>HBS093</b> ☒ M10x1.25x172.00mm (x10)	<b>JD153</b> ■ <b>JD151</b> <b>JD5997</b> ■ ■	<b>JN928</b>	<b>HR800</b> ■ ■	<b>NA5053</b> 30.00x42.00x7.00mm FPM



BT440

<b>477</b>	<b>84.00</b>	<b>Petrol</b>				
<b>836 A3.011</b>	4 Cyl.	10.5:1	1995cc	<b>102-104kW (139-141)PS</b>	<b>TD26168</b>	<b>1146</b>
						<b>NA5053</b> 30.00x42.00x7.00mm FPM



<b>478</b>	<b>84.00</b>	<b>Petrol</b>					
<b>838 A4.000</b>	4 Cyl.	8:1	1995cc	<b>151kW (205)PS</b>	<b>Turbocharged</b>	<b>TD4619</b>	<b>1147</b>
<b>TB474</b> 173x18 →02/98						<b>FOL106</b> (x16) Height: 24mm <b>FOL145</b> (x16) Height: 26mm	
<b>TB579</b> 97x15 →12/98						Driven unit: balance shaft	

B x C x D	OE	MAT.			E x F x G
<b>V91935</b> ■	7 722 907		45°		<b>VAG92496</b> ■ ■ ■
34.40 x 7.00 x 128.00		MD cr			51.00 x 7.03 x 14.04
<b>V91936</b> ■	7 650 916		45°		<b>VAG96181B</b> ■ ■ ■
28.35 x 7.00 x 125.50		MD cr			51.30 x 7.04 x 14.05
					<b>VAG96199</b> ■ ■ ■
					51.30 x 7.04 x 14.08

<b>BT440</b> Fibre Composite	<b>DT448</b>		<b>HBS093</b> ☼ M10x1.25x172.00mm (x10)	<b>JD153</b> ■ <b>JD151</b> <b>JD5997</b> ■	<b>JN928</b>		<b>NA5053</b> 30.00x42.00x7.00mm FPM



BT440

<b>479</b>	<b>84.00</b>	<b>Petrol</b>					
<b>6132 AZ 2.000</b>	4 Cyl.	1995cc	<b>59kW (80)PS</b>	<b>TD13508</b>	<b>1148</b>		
<b>BP190</b> Fibre Composite	<b>DP190</b>			<b>JE390</b> ■		<b>HR596</b> ■	



BP190

# FIAT GROUP

## 480



84.00

Petrol



AR 06476      4 Cyl.      1995cc      128-129kW (174-175)PS      Turbocharged      TD65      1150



**TB579**  
97x15  
02/88 → 10/92  
Driven unit: balance shaft

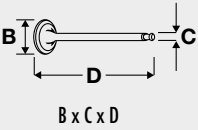

OE

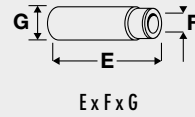

**V91290** ■  
43.50 x 8.00 x 105.70

46 406 169

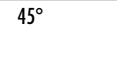
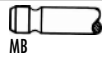

H

**VAG96171** ■  
42.00 x 8.02 x 14.06



**V91394** ■  
36.50 x 8.00 x 105.50

5 953 041

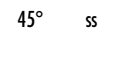
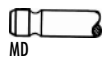

ss

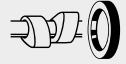
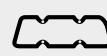

**BT420** Fibre Composite  
→Eng.1033624

**DT420**  
01/88 → 12/89  
→Eng.1033624

**HBS092** ☒  
M10x1.25x115.00mm (x10)

**JC662** ■  
**JD019** ■

**JN643** (x2)

**HR363** ■

**NA5187**  
30.00x52.00x7.00mm ACM

**BT440** Fibre Composite  
Eng.1033625 →



BT420, BT440

## 481



84.00

Petrol



AR 67201      4 Cyl.      10:1      1995cc      106kW (144)PS      TD136      1151

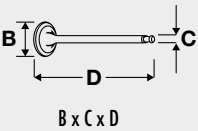

OE

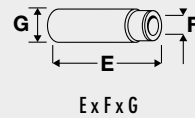

**V91308** ■  
44.00 x 8.00 x 116.00

605 64 098

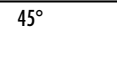
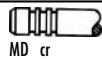

H

**VAG96260B** ■  
48.00 x 8.00 x 15.07



**VAG96268** ■  
45.00 x 8.00 x 15.07

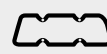

**BW410** Fibre Composite

**DW410**

**GW410**

**JD235** ■  
**JD015** ■ (x4)

**JN940**

**HR363** ■

**NA5163**  
32.00x47.00x10.00mm FPM



BW410

**482**  **84.00** **Petrol** 

AR 67203 4 Cyl. 1995cc 137-140kW (186-190)PS Turbocharged TD138 1152



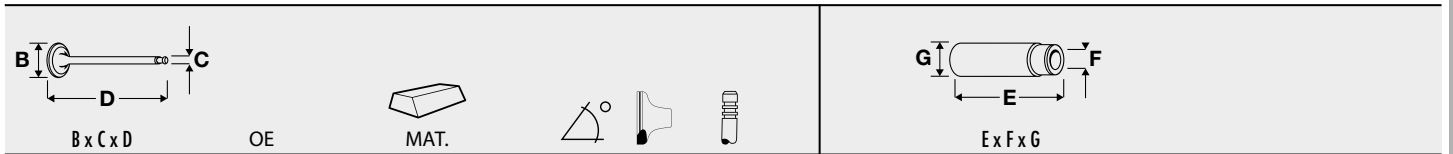

**TB474**  
173x18  
**TB579**  
97x15  
Driven unit: balance shaft

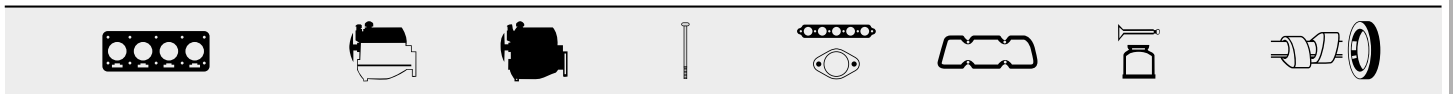

<b>V91935</b>  34.40 x 7.00 x 128.00 <b>V91936</b>  28.35 x 7.00 x 125.50	OE 7 722 907 7 650 916	MAT.  MD cr MD cr	45° 45°	<b>VAG92496</b>  51.00 x 7.03 x 14.04
--	------------------------------	---	------------	---



<b>BT440</b> Fibre Composite	<b>DT447</b>	<b>GT447</b>	<b>HBS093</b>  M10x1.25x172.00mm (x10)	<b>JD151</b>	<b>JN928</b>	<b>HR599</b> 	<b>NA5053</b> 30.00x42.00x7.00mm FPM
------------------------------	--------------	--------------	--	--------------	--------------	--	---



BT440

**483**  **85.00** **Diesel** 

**DW10BTED4** 4 Cyl. 17.6:1 1997cc 100kW (136)PS Turbo Intercooled TD25755 1154  
**RHK (DW10UTED4) Euro 4 (D4)** 4 Cyl. 17.5:1 1997cc 79-88kW (107-120)PS Turbo Intercooled TD26952 1159



**TB742**  
116x25  
**TBK338**  
Component No: TB742;  
AE1181GP;AE1177TP

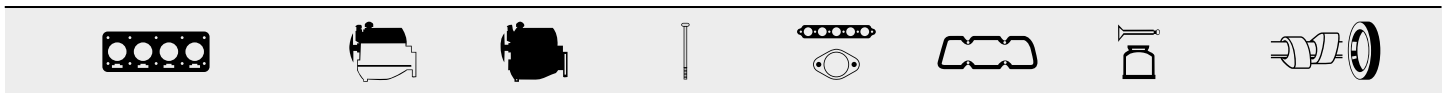

							<b>NA5035</b> 27.00x47.00x7.00mm FPM
--	--	--	--	--	--	--	---

**484**  **85.00** **Petrol** 

**RFH (EW10A) Euro 4 (D4)** 4 Cyl. 11:1 1997cc 103kW (140)PS TD25732 1155

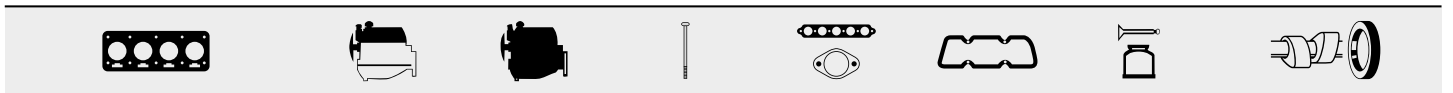

<b>AH6630</b> MLS 01/01 →			<b>HBS535</b>  M11x1.50x128.00mm (x10)				<b>NF817</b> 36.00x50.00x7.00mm FPM
------------------------------	--	--	--	--	--	--	--

















AH6630

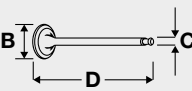
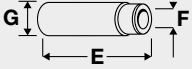











# FIAT GROUP

**485**  **85.00** **Petrol** 

**RFN (EW10J4)** 4 Cyl. 10.8:1 1997cc **100kW (136)PS** **TD16788** **1156**

	 <b>.KIT</b>		 <b>KIT</b>		
<b>TB683</b> 153x25.4	<b>TBK279</b> Component No: TB683; AE1154GP;AE1153TP				

	
B x C x D	E x F x G
<b>V94200</b>  <b>0948.99</b>	 <b>MAT.</b>  <b>45°</b>  <b>H</b>
<b>V94201</b>  <b>0949.99</b>	 <b>MG cr</b>  <b>45° ss</b>  <b>H</b>







							
<b>AD5300</b> <b>MS</b>	<b>CD5300</b>		<b>HBS259</b>  <b>M11x1.50x144.50mm (x10)</b>	<b>JD536</b>  <b>→Eng.07328</b> <b>JD539</b>  <b>(x4)</b>	<b>JM5139</b>  <b>[5]</b> <b>JM5283</b>  <b>[5]</b>		<b>NF817</b> 36.00x50.00x7.00mm <b>FPM</b>











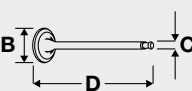
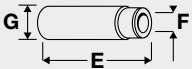









**AD5300**  
[5] Specification: Edge Moulded      [5] Spécification: bord moulé      [5] Specificazione: bordo modellato      [5] Especificación: borde moldeado

**486**  **85.00** **Petrol** 

**RFN (EW10J4)** 4 Cyl. 10.8:1 1997cc **100kW (136)PS** **TD16734** **1156**









	 <b>.KIT</b>		 <b>KIT</b>		
<b>TB683</b> 153x25.4	<b>TBK279</b> Component No: TB683; AE1154GP;AE1153TP				









	
B x C x D	E x F x G
<b>V94200</b>  <b>0948.99</b>	 <b>MAT.</b>  <b>45°</b>  <b>H</b>
<b>V94201</b>  <b>0949.99</b>	 <b>MG cr</b>  <b>45° ss</b>  <b>H</b>

							
<b>AD5300</b> <b>MS</b>			<b>HBS259</b>  <b>M11x1.50x144.50mm (x10)</b>				<b>NF817</b> 36.00x50.00x7.00mm <b>FPM</b>



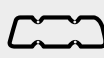

**AD5300**



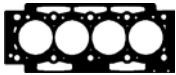



<b>487</b>	 <b>85.00</b>	<b>Petrol</b>				
<b>RFN</b>	4 Cyl.	10.8:1	1997cc	<b>100kW (136)PS</b>	<b>TD16322</b>	<b>1157</b>
						
<b>TB683</b> 153x25.4	<b>TBK279</b> Component No: TB683; AE1154GP;AE1153TP		<b>KIT</b>			

							
<b>AD5300</b> MLS			<b>HBS259</b>  M11x1.50x144.50mm (x10)				<b>NF817</b> 36.00x50.00x7.00mm FPM

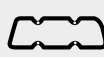

AD5300

<b>488</b>	 <b>85.00</b>	<b>Diesel</b>					
<b>RH02</b>	4 Cyl.	17.5:1	1997cc	<b>94kW (128)PS</b>	<b>Turbo Intercooled</b>	<b>TD26194</b>	<b>1153</b>
<b>RHH Euro 5</b>	4 Cyl.	16:1	1997cc	<b>120kW (163)PS</b>	<b>Turbo Intercooled</b>	<b>TD24777</b>	<b>1158</b>

							
<b>AH7290</b> MLS, 1.25mm, 3 Holes <b>AH7300</b> MLS, 1.30mm, 4 Holes <b>AH7310</b> MLS, 1.35mm, 5 Holes <b>AH7320</b> MLS, 1.40mm, 4 Holes							<b>NA5035</b> 27.00x47.00x7.00mm FPM























AH7290

AH7300

AH7310

AH7320

<b>489</b>	 <b>85.00</b>	<b>Diesel</b>					
<b>RHK</b>	4 Cyl.	17.5:1	1997cc	<b>88kW (120)PS</b>	<b>Turbo Intercooled</b>	<b>TD20267</b>	<b>1160</b>
							
<b>TB742</b> 116x25	<b>TBK338</b> Component No: TB742; AE1181GP;AE1177TP		<b>KIT</b>				

							
<b>AD5490</b> MLS, 1.250mm, 2 Notches <b>AD5500</b> MLS, 1.300mm, 3 Holes <b>AD5510</b> MLS, 1.350mm, 4 Holes <b>AD5520</b> MLS, 1.400mm, 5 Holes	<b>CD5500</b> ▲		<b>HBS261</b>  M12x1.50x126.00mm (x10)	<b>JD5881</b> 	<b>HM5289</b> 	<b>HR5046</b> (x2) 	<b>NA5035</b> 27.00x47.00x7.00mm FPM



AD5490, AD5500, AD5510, AD5520

# FIAT GROUP

<b>490</b>	<b>85.00</b>	<b>Diesel</b>					
<b>RHM (DW10ATED4)</b>	4 Cyl.	1997cc	<b>79kW (107)PS</b>	<b>Turbo Intercooled</b>	<b>TD18906</b>	<b>1161</b>	
<b>TB720</b> 144x25.4		<b>CAM750</b> ■ <b>CAM751</b> ■					









B x C x D	OE	MAT.	45°	H	E	G	F
<b>V94438</b> ■ 29.90 x 6.00 x 106.20	9 635 317 980	 MB cr	45°	H		<b>VAG96119</b> ■ ■ ■ 41.50 x 6.03 x 10.54	
<b>V94486</b> ■ 29.90 x 6.00 x 106.20	0948.C0	 MB cr	45°	Y	H		
<b>V94487</b> ■ 25.00 x 6.00 x 106.10	0949.A9	 MG cr	45°	ss	H		







<b>AD5490</b> MLS, 1.250mm, 2 Notches <b>AD5520</b> MLS, 1.400mm, 5 Holes	<b>CC5010</b> ▲ <b>CD5490</b> ▲		<b>HBS261</b> ⊕ M12x1.50x126.00mm (x10)	<b>JD5881</b> ■	<b>HM5289</b> ■	<b>HR5046</b> (x2) ■ <b>HR5064</b> ■	<b>NA5035</b> 27.00x47.00x7.00mm FPM
<b>AD5490, AD5520</b>							

<b>491</b>	<b>85.00</b>	<b>Diesel</b>					
<b>RHM (DW10ATED4)</b>	4 Cyl.	17.6:1	1997cc	<b>79kW (107)PS</b>	<b>Turbo Intercooled</b>	<b>TD26957</b>	<b>1159</b>
<b>TB720</b> 144x25.4							
							<b>NA5035</b> 27.00x47.00x7.00mm FPM

<b>492</b>	<b>85.00</b>	<b>Diesel</b>					
<b>RHR (DW10BTED4) Euro 4 (D4)</b>	4 Cyl.	18:1	1997cc	<b>100kW (136)PS</b>	<b>Turbo Intercooled</b>	<b>TD26955</b>	<b>1162</b>
<b>TB742</b> 116x25	<b>TBK338</b> Component No: TB742; AE1181GP;AE1177TP						
<b>AD5490</b> MLS, 1.250mm, 2 Notches <b>AD5500</b> MLS, 1.300mm, 3 Holes <b>AD5510</b> MLS, 1.350mm, 4 Holes <b>AD5520</b> MLS, 1.400mm, 5 Holes	<b>CD5500</b> ▲		<b>HBS261</b> ⊕ M12x1.50x126.00mm (x10)	<b>JD5881</b> ■	<b>HM5289</b> ■		



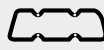





<b>AD5490, AD5500, AD5510, AD5520</b>							







<b>493</b>	 <b>85.00</b>	<b>Diesel</b>					
<b>RHR</b>	4 Cyl.	18:1	1997cc	<b>100kW (136)PS</b>	<b>Turbo Intercooled</b>	<b>TD20268</b>	<b>1162</b>
							
<b>TB742</b> 116x25	<b>TBK338</b> Component No: TB742; AE1181GP;AE1177TP						



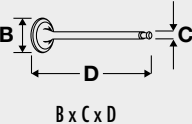



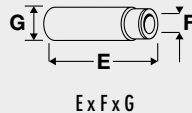
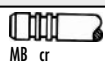

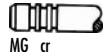
							
<b>AD5490</b> MLS, 1.250mm, 2 Notches <b>AD5500</b> MLS, 1.300mm, 3 Holes <b>AD5510</b> MLS, 1.350mm, 4 Holes <b>AD5520</b> MLS, 1.400mm, 5 Holes	<b>CD5500</b> ▲		<b>HBS261</b> ☉ M12x1.50x126.00mm (x10)	<b>JD5190</b> ☒	<b>JM5087</b> (Elastomer) <b>HM5289</b> ☒	<b>HR5046</b> (x2) ☒	<b>NA5035</b> 27.00x47.00x7.00mm FPM



AD5490, AD5500, AD5510, AD5520

<b>494</b>	 <b>85.00</b>	<b>Diesel</b>					
<b>RHV (DW10)</b>	4 Cyl.	18:1	1997cc	<b>62kW (84)PS</b>	<b>Turbo Intercooled</b>	<b>TD16406</b>	<b>1163</b>
							
<b>TB632</b> 141x25.4 →07/06	<b>TBK106</b> →07/06 Component No: TB632; AE1165TP;AE1166GP	<b>CAM679</b>		<b>FOL163</b> (x8)	<b>FOL154</b> (x8)		

				
<b>V94178</b> ☐ 35.60 x 6.00 x 107.10	0948.95  MB cr	45°	H	<b>VAG96119</b> ☐ ☒ 41.50 x 6.03 x 10.54 
<b>V94179</b> ☒ 33.80 x 6.00 x 107.10	0949.96  MG cr	45°	H	

							
<b>AC5012</b> MLS, 1.300mm, 1 Hole ☐(0.47)→(0.605) mm <b>AC5020</b> MLS, 1.350mm, 2 Holes ☐(0.605)→(0.655) mm <b>AC5032</b> MLS, 1.400mm, 3 Holes ☐(0.655)→(0.705) mm <b>AC5040</b> MLS, 1.450mm, 4 Holes ☐(0.705)→(0.755) mm <b>AC5052</b> MLS, 1.500mm, 5 Holes ☐(0.755)→(0.83) mm	<b>CC5010</b> ▲		<b>HBS261</b> ☉ M12x1.50x126.00mm (x10)	<b>JD5291</b> ☐ <b>JD5190</b> ☒	<b>JM5087</b> (Elastomer)	<b>HR5046</b> ☒	<b>NA5035</b> 27.00x47.00x7.00mm FPM



AC5012



AC5020, AC5040



AC5032



AC5052

# FIAT GROUP

## 495

85.00

**Diesel**



RHW (DW10ATED4)

4 Cyl.

18:1

1997cc

80kW (109)PS

Turbo Intercooled

TD16789

1162

<b>TB720</b> 144x25.4 →07/06		<b>CAM750</b> ■ <b>CAM751</b> ■		<b>FOL163</b> (x16)	<b>FOL190</b> (x16)

B x C x D	OE	MAT.	E x F x G
<b>V94438</b> ■ 29.90 x 6.00 x 106.20	9 635 317 980	 MB cr	<b>VAG96119</b> ■ ■ ■ 41.50 x 6.03 x 10.54
<b>V94486</b> ■ 29.90 x 6.00 x 106.20	0948.C0	 MB cr	
<b>V94487</b> ■ 25.00 x 6.00 x 106.10	0949.A9	 MG cr	

<b>AD5490</b> MLS, 1.250mm, 2 Notches <b>AD5500</b> MLS, 1.300mm, 3 Holes <b>AD5510</b> MLS, 1.350mm, 4 Holes <b>AD5520</b> MLS, 1.400mm, 5 Holes	<b>CD5490</b> ▲		<b>HBS261</b> ☉ M12x1.50x126.00mm (x10)	<b>JD5881</b> ■	<b>JM5141</b> (Elastomer)	<b>HR5046</b> (x2) ■	<b>NA5035</b> 27.00x47.00x7.00mm FPM



AD5490, AD5500, AD5510, AD5520

## 496

85.00

**Diesel**



RHW (DW10ATED4)

4 Cyl.

17.1:1

1997cc

80kW (109)PS

Turbo Intercooled

TD16735

1164

<b>TB720</b> 144x25.4 08/01→06/07		<b>CAM750</b> ■ <b>CAM751</b> ■		<b>FOL163</b> (x16)	<b>FOL190</b> (x16)

B x C x D	OE	MAT.	E x F x G
<b>V94438</b> ■ 29.90 x 6.00 x 106.20	9 635 317 980	 MB cr	<b>VAG96119</b> ■ ■ ■ 41.50 x 6.03 x 10.54
<b>V94486</b> ■ 29.90 x 6.00 x 106.20	0948.C0	 MB cr	
<b>V94487</b> ■ 25.00 x 6.00 x 106.10	0949.A9	 MG cr	

<b>AD5490</b> MLS, 1.250mm, 2 Notches <b>AD5500</b> MLS, 1.300mm, 3 Holes <b>AD5510</b> MLS, 1.350mm, 4 Holes <b>AD5520</b> MLS, 1.400mm, 5 Holes			<b>HBS261</b> ☉ M12x1.50x126.00mm (x10)		<b>JM5141</b> (Elastomer)		<b>NA5035</b> 27.00x47.00x7.00mm FPM



AD5490, AD5500, AD5510, AD5520



## 497



85.00

Diesel



RHX	4 Cyl.	17.6:1	1997cc	69kW (94)PS	Turbo Intercooled	TD16299	1165
RHZ	4 Cyl.	17.6:1	1997cc	80kW (109)PS	Turbo Intercooled	TD16324	1165

<b>TB632</b> 141x25.4 →10/06	<b>TBK106</b> →04/00 Component No: TB632; AE1165TP;AE1166GP <b>TBK274</b> 04/00→10/06 Component No: TB632; AE1090GP;AE1091GP	<b>CAM679</b>	<b>KIT</b>	<b>FOL163</b> (x8)	<b>FOL154</b> (x8)

B x C x D	E x F x G
<b>V94178</b> ■ 35.60 x 6.00 x 107.10	<b>VAG96119</b> ■ ■ 41.50 x 6.03 x 10.54
<b>V94179</b> ■ 33.80 x 6.00 x 107.10	

<b>AC5012</b> MLS, 1.300mm, 1 Hole ⊖(0.47)→(0.605) mm	<b>CC5010</b> ▲	<b>HBS261</b> ⊕ M12x1.50x126.00mm (x10)	<b>JD5191</b> ■ <b>JD5190</b> ■	<b>JM5087</b> (Elastomer)	<b>HR5064</b> ■	<b>NA5035</b> 27.00x47.00x7.00mm FPM
<b>AC5020</b> MLS, 1.350mm, 2 Holes ⊖(0.605)→(0.655) mm						
<b>AC5032</b> MLS, 1.400mm, 3 Holes ⊖(0.655)→(0.705) mm						
<b>AC5040</b> MLS, 1.450mm, 4 Holes ⊖(0.705)→(0.755) mm						
<b>AC5052</b> MLS, 1.500mm, 5 Holes ⊖(0.755)→(0.83) mm						
AC5012	AC5020, AC5040	AC5032	AC5052			

# FIAT GROUP

**498**



85.00

Diesel



RHZ (DW10ATED)

4 Cyl.

18:1

1997cc

80kW (109)PS

Turbocharged

TD26954

1159



**TB632**  
141x25.4  
→07/01

**TBK274**  
→07/01  
Component No: TB632;  
AE1090GP;AE1091GP

**FOL190** (x8)

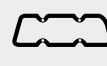

**AC5012** MLS, 1.300mm, 1 Hole  
☞(0.47)→(0.605) mm

**CC5010** ▲

**HBS261** ☞  
M12x1.50x126.00mm (x10)

**JD5191** ■  
**JD5190** ■

**NA5035**  
27.00x47.00x7.00mm FPM

**AC5020** MLS, 1.350mm, 2 Holes  
☞(0.605)→(0.655) mm

**AC5032** MLS, 1.400mm, 3 Holes  
☞(0.655)→(0.705) mm

**AC5040** MLS, 1.450mm, 4 Holes  
☞(0.705)→(0.755) mm

**AC5052** MLS, 1.500mm, 5 Holes  
☞(0.755)→(0.83) mm



AC5012

AC5020, AC5040

AC5032

AC5052

**499**



85.00

Diesel



P8C

4 Cyl.

21.5:1

2088cc

80kW (109)PS

Turbo Intercooled

TD960

1167



**TB320**  
149x25.4

**TBK035**  
Component No: TB320;  
AE1071TP;AE1044GP

**FOL109** (x12)

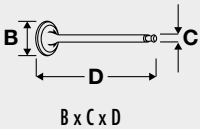

OE



MAT.



45°



H

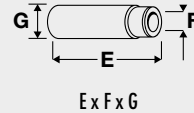

E x F x G

**V94169** ■  
33.90 x 8.00 x 122.30

96 008 334

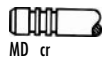
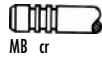

**V94170** ■  
33.90 x 8.00 x 121.90

96 109 183

**VAG96215B** ■ ■ ■  
54.50 x 8.02 x 13.09

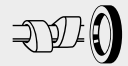
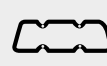

**BY942** MLS, 1.520mm

**DV150** ▲

**HBS125** ☞  
M12x1.50x150.50mm (x10)

**JD5291** ■  
**JD230** ■

**JP045**

**HR805** ■

**NF841** ■  
35.00x50.00x8.00mm FPM

☞(0.65)→(0.76) mm

**BY950** MLS, 1.570mm

☞(0.77)→(0.81) mm

**BY970** MLS, 1.670mm

**BY962** MLS, 1.620mm

10/94 →

☞(0.82)→(0.86) mm

**BY982** MLS, 1.720mm

10/94 →

☞(0.92)→(0.96) mm



BY942

BY950, BY970

BY962

BY982

<b>500</b>	<b>85.00</b>	<b>Diesel</b>					
<b>P 8 C</b>	4 Cyl.	21.5:1	2088cc	<b>80kW (109)PS</b>	<b>Turbocharged</b>	<b>TD1859</b>	<b>1166</b>
<b>TB320</b> 149x25.4	<b>TBK035</b> Component No: TB320; AE1071TP;AE1044GP		<b>KIT</b>				

B x C x D	E x F x G
<b>V94169</b>	<b>VAG96215B</b>
33.90 x 8.00 x 122.30	54.50 x 8.02 x 13.09
<b>V94170</b>	
33.90 x 8.00 x 121.90	

<b>BY942</b> MLS, 1.520mm ⊖(0.65)→(0.76) mm	<b>DV150</b> ▲	<b>HBS125</b> ⊕ M12x1.50x150.50mm (x10)	<b>JD529</b> ■ <b>JD230</b> ■	<b>NF841</b> 35.00x50.00x8.00mm FPM
<b>BY950</b> MLS, 1.570mm ⊖(0.77)→(0.81) mm				
<b>BY962</b> MLS, 1.620mm ⊖(0.82)→(0.86) mm				
<b>BY970</b> MLS, 1.670mm				
<b>BY982</b> MLS, 1.720mm ⊖(0.92)→(0.96) mm				

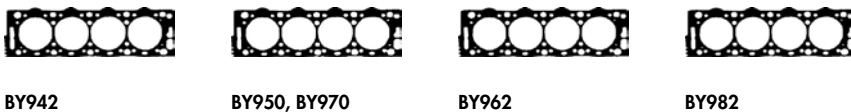

<b>501</b>	<b>85.00</b>	<b>Diesel</b>					
<b>4HP</b>	4 Cyl.	2179cc	<b>120kW (163)PS</b>	<b>Turbo Intercooled</b>	<b>TD24689</b>	<b>1153</b>	
<b>4HP</b>	4 Cyl.	2179cc	<b>120kW (163)PS</b>	<b>Turbo Intercooled</b>	<b>TD24945</b>	<b>1153</b>	
<b>4HR</b>	4 Cyl.	2179cc	<b>120kW (163)PS</b>	<b>Turbo Intercooled</b>	<b>TD24690</b>	<b>1168</b>	
<b>4HR</b>	4 Cyl.	2179cc	<b>120kW (163)PS</b>	<b>Turbo Intercooled</b>	<b>TD24946</b>	<b>1168</b>	
<b>4HS Euro 4 (D4)</b>	4 Cyl.	16.6:1	2179cc	<b>125kW (170)PS</b>	<b>Turbo Intercooled</b>	<b>TD24688</b>	<b>1168</b>
<b>4HS Euro 4 (D4)</b>	4 Cyl.	16.6:1	2179cc	<b>125kW (170)PS</b>	<b>Turbo Intercooled</b>	<b>TD24775</b>	<b>1168</b>

				<b>NA5035</b> 27.00x47.00x7.00mm FPM

# FIAT GROUP

## 502

85.00

**Diesel**



4HT (DW12BTD4) Euro 4 (D4) 4 Cyl. 16.6:1 2179cc 125kW (170)PS Bi-Turbocharged Intercooled TD25656 **1168**

					<b>FOL190</b> (x16)

	OE						
<b>V95083</b> ■ 27.25 x 5.97 x 95.70	0948.E5		45°	Y	H	<b>VAG96119</b> ■ ■ ■ 41.50 x 6.03 x 10.54	
<b>V95084</b> ■ 25.00 x 5.97 x 95.00	0949.E1		45°	ss	H		

							<b>NA5035</b> 27.00x47.00x7.00mm FPM

## 503

85.00

**Diesel**



4HT Euro 4 (D4) 4 Cyl. 17.5:1 2179cc 125kW (170)PS Bi-Turbocharged Intercooled TD24686 **1168**

					<b>FOL190</b> (x16)

	OE						
<b>V95083</b> ■ 27.25 x 5.97 x 95.70	0948.E5		45°	Y	H	<b>VAG96119</b> ■ ■ ■ 41.50 x 6.03 x 10.54	
<b>V95084</b> ■ 25.00 x 5.97 x 95.00	0949.E1		45°	ss	H		

						<b>HM5369</b> ■	<b>NA5035</b> 27.00x47.00x7.00mm FPM

<b>504</b>	<b>85.00</b>	<b>Diesel</b>					
<b>4HW(DW12ATED4)</b>	4 Cyl.	18:1	2179cc	<b>94kW (128)PS</b>	<b>Turbo Intercooled</b>	<b>TD16736</b>	<b>1170</b>
<b>TB678</b> 146x25.4	<b>TBK303</b> →04/04 Component No: TB678; AE1091GP;AE1165TP <b>TBK355</b> 05/04→ Component No: TB678; AE1180GP;AE1179TP	<b>CAM750</b> <b>CAM751</b>					<b>FOL115</b> (x16)

<b>AD5490</b> MLS, 1.250mm, 2 Notches <b>AD5500</b> MLS, 1.300mm, 3 Holes <b>AD5510</b> MLS, 1.350mm, 4 Holes <b>AD5520</b> MLS, 1.400mm, 5 Holes	<b>CD5490</b> ▲		<b>HBS261</b> M12x1.50x126.00mm (x10)		<b>JM5141</b> (Elastomer)		<b>NA5035</b> 27.00x47.00x7.00mm FPM



AD5490, AD5500, AD5510, AD5520

<b>505</b>	<b>85.00</b>	<b>Diesel</b>					
<b>4HW (DW12ATED4)</b>	4 Cyl.	18:1	2179cc	<b>94kW (128)PS</b>	<b>Turbo Intercooled</b>	<b>TD16790</b>	<b>1169</b>
<b>TB678</b> 146x25.4	<b>TBK303</b> →04/04 Component No: TB678; AE1091GP;AE1165TP <b>TBK355</b> 05/04→ Component No: TB678; AE1180GP;AE1179TP	<b>CAM750</b> <b>CAM751</b>					<b>FOL115</b> (x16)

<b>V94490</b> 29.80 x 6.00 x 105.00 <b>V94491</b> 25.00 x 6.00 x 105.00	OE 9 627 184 380 9 634 437 580	MAT.  MB cr  MG cr	45° 45°	Y ss	H H		<b>VAG96119</b> 41.50 x 6.03 x 10.54

<b>AD5490</b> MLS, 1.250mm, 2 Notches <b>AD5500</b> MLS, 1.300mm, 3 Holes <b>AD5510</b> MLS, 1.350mm, 4 Holes <b>AD5520</b> MLS, 1.400mm, 5 Holes	<b>CD5490</b> ▲		<b>HBS261</b> M12x1.50x126.00mm (x10)		<b>JM5141</b> (Elastomer)	<b>HR5046</b>	<b>NA5035</b> 27.00x47.00x7.00mm FPM



AD5490, AD5500, AD5510, AD5520

# FIAT GROUP

## 506

86.00

**Petrol**



128 A1.000	4 Cyl.	9:1	1290cc	44kW (60)PS	TD889	1172
128 AC.000	4 Cyl.	9:1	1290cc	55kW (75)PS	TD890	1172

CAM517			FOL104 (x8) [6]		
[6] Mechanical	[6] Mécanique	[6] Meccanico	[6] Mecánico		

	OE	MAT.			
B x C x D				H	E x F x G
<b>V34496</b>	4 239 917		45°		<b>VAG92366</b>
36.00 x 8.00 x 108.50		MB			46.50 x 8.00 x 14.10
<b>V90071</b>	4 315 062		45°		
30.99 x 8.00 x 109.09		MD cr			
<b>V91713</b>	4 315 062		45°		
31.00 x 8.00 x 109.00		MD cr			

BP110 Fibre Composite	DJ851 ▲ DP110			JD146 JE390	JM663 JN805	HR569	NA5187 30.00x52.00x7.00mm ACM



BP110

## 507

86.00

**Petrol**



128 AS.000	4 Cyl.	9.2:1	1290cc	54-55kW (73-75)PS	TD995	1173
------------	--------	-------	--------	-------------------	-------	------

					FOL104 (x8) [6]
[6] Mechanical	[6] Mécanique	[6] Meccanico	[6] Mecánico		

	OE	MAT.			
B x C x D				H	E x F x G
<b>V34496</b>	4 239 917		45°		<b>VAG92366</b>
36.00 x 8.00 x 108.50		MB			46.50 x 8.00 x 14.10
<b>V90071</b>	4 315 062		45°		
30.99 x 8.00 x 109.09		MD cr			
<b>V91713</b>	4 315 062		45°		
31.00 x 8.00 x 109.00		MD cr			

BP110 Fibre Composite	DJ851 ▲ DP110				JM663 JN805	HR300 HR569	



BP110

<b>508</b>	<b>86.00</b>	<b>Petrol</b>	
<b>939 A6.000</b>	4 Cyl.	11.3:1	1859cc
			<b>118kW (160)PS</b>
			<b>TD18475 1174</b>

B x C x D	OE	MAT.	45°			E x F x G
<b>V94962</b> ■ 35.15 x 6.00 x 102.20	641 063	MB cr	45°		H	
<b>V98003</b> ■ 35.00 x 6.00 x 102.20	55192156	MB cr	45°			
<b>V94963</b> ■ 30.10 x 6.00 x 100.90	641 376	MG cr	45°	ss	H	
<b>V98004</b> ■ 30.00 x 6.00 x 100.10	71739686	MG cr	45°			

<b>509</b>	<b>86.00</b>	<b>Petrol</b>	
<b>RFL</b>	4 Cyl.	9.5:1	1998cc
			<b>81kW (110)PS</b>
			<b>TD16405 1175</b>

<b>TB454</b> 114x25.4 →07/06	<b>TBK344</b> →07/06 Component No: TB454; AE1084TP			

B x C x D	OE	MAT.	45°			E x F x G
<b>V91972</b> ■ 42.60 x 8.00 x 108.80	96 059 361	MB	45°		H	<b>VAG96047</b> ■ 43.50 x 8.02 x 13.09
<b>V91970</b> ■ 34.50 x 8.00 x 108.40	96 147 032	MG cr	45°	ss	H	

<b>BY320</b> Fibre Composite, 1.450mm	<b>CY081</b> ▲ <b>DS820</b> ▲		<b>HBS245</b> ☉ M12x1.50x125.00mm (x10)	<b>JN547</b>	<b>NF817</b> 36.00x50.00x7.00mm FPM



BY320

# FIAT GROUP

## 510

86.00

Petrol



RFV (XU10J2C)

4 Cyl.

9.5:1

1998cc

89kW (121)PS

TD4349

1176



**TB419**  
114x17  
→12/00, HNBR  
**TB346**  
114x17  
→12/00  
Polychloroprene (Neoprene)

**TBK010**  
→12/00  
Component No: TB419;  
AE1026TP

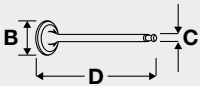

B x C x D

OE



MAT.



45°

H

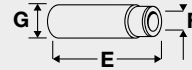

E x F x G

**V91972** ■  
42.60 x 8.00 x 108.80

96 059 361



MB

**V91970** ■  
34.50 x 8.00 x 108.40

96 147 032



MG cr

**VAG96047** ■  
43.50 x 8.02 x 13.09

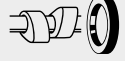
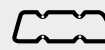

**BV140** Fibre Composite, 1.250mm  
**BY320** Fibre Composite, 1.450mm

**CY082** ▲

**HBS084** Ⓢ  
M12x1.50x120.00mm (x10)

**NF817** ■  
36.00x50.00x7.00mm FPM



BV140, BY320

## 511

86.00

Petrol



RFV (XU10J4R)

4 Cyl.

10.4:1

1998cc

97kW (132)PS

TD26959

1177



**TB479**  
136x25.4  
02/99→

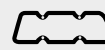

**BV140** Fibre Composite, 1.250mm

**HBS087** Ⓢ  
M12x1.50x110.00mm (x10)

**JD536** ■

**JM7121** ■  
(Elastomer)

**NF817**  
36.00x50.00x7.00mm FPM















BV140



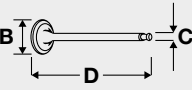



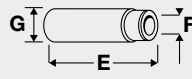

**512**  **86.00** **Petrol** 

RFV 4 Cyl. 10.4:1 1998cc 97-100kW (132-136)PS TD18824 1178

					
<b>TB479</b> 136x25.4 09/98 →	<b>TBK113</b> 09/98 → Component No: TB479; AE1084TP;AE1044GP				

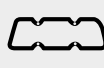
					
B x C x D	OE	MAT.	45°	Y	H
<b>V94175</b> ■ 34.60 x 6.00 x 106.40	96 289 433		45°	Y	H
<b>V94176</b> ■ 29.60 x 6.00 x 105.80	96 298 611		45°	ss	H







							
<b>AY070</b> Fibre Composite <b>BV140</b> Fibre Composite, 1.250mm			<b>HBS087</b> Ⓢ M12x1.50x110.00mm (x10) →Eng.08581		<b>JM7121</b> ■ (Elastomer)		<b>NF817</b> 36.00x50.00x7.00mm FPM











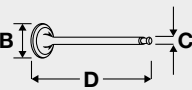



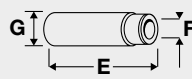

AY070 BV140

**513**  **86.00** **Petrol** 

RFW 4 Cyl. 9.5:1 1998cc 80kW (109)PS TD6808 1176

					
<b>TB454</b> 114x25.4 →11/01	<b>TBK344</b> →11/01 Component No: TB454; AE1084TP				

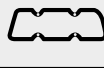
				
B x C x D	OE	MAT.	45°	H
<b>V91972</b> ■ 42.60 x 8.00 x 108.80	96 059 361		45°	H
<b>V91970</b> ■ 34.50 x 8.00 x 108.40	96 147 032		45°	ss
				<b>VAG96047</b> ■ 43.50 x 8.02 x 13.09

							
<b>BV140</b> Fibre Composite, 1.250mm <b>BY320</b> Fibre Composite, 1.450mm	<b>CY081</b> ▲		<b>HBS084</b> Ⓢ M12x1.50x120.00mm (x10)				<b>NF817</b> ■ 36.00x50.00x7.00mm FPM



BV140, BY320

# FIAT GROUP

**514**

 **86.00**

**Petrol**



**RGX (XU10J2CTE)**

4 Cyl.

8.5:1

1998cc

108kW (147)PS

Turbo Intercooled

**TD4355**

**1179**



**KIT**



**TB419**  
114x17  
→12/00, HNBR  
**TB346**  
114x17  
→12/00  
Polychloroprene (Neoprene)

**TBK010**  
→12/00  
Component No: TB419;  
AE1026TP

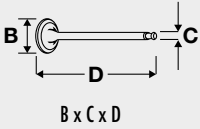

OE



MAT.



45°

ss



H

**V91972** ■  
42.60 x 8.00 x 108.80  
**V91971** ■  
34.50 x 8.00 x 108.40

96 059 361

0949.76



MB



MG cr

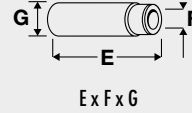

**VAG96047** ■  
43.50 x 8.02 x 13.09

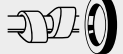
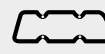

**BT440** Fibre Composite  
**BY310** Fibre Composite, 1.250mm  
**BY320** Fibre Composite, 1.450mm

**DY310** ▲

**HBS084** ⊕  
M12x1.50x120.00mm (x10)

**JD153** ■  
**JD151**

**JN547**

**NF817**  
36.00x50.00x7.00mm FPM



**BT440**

**BY310, BY320**

**515**

 **86.00**

**Petrol**



**RGX (XU10J2TE)**

4 Cyl.

8.8:1

1998cc

108kW (147)PS

Turbocharged

**TD26958**

**1180**



**KIT**



**TB419**  
114x17  
→12/99, HNBR  
**TB346**  
114x17  
→12/99  
Polychloroprene (Neoprene)









**TBK010**  
→12/99  
Component No: TB419;  
AE1026TP



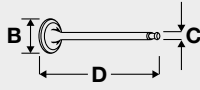

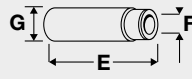



**BY310** Fibre Composite, 1.250mm





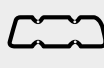



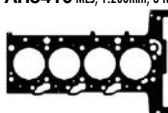
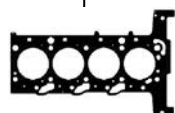
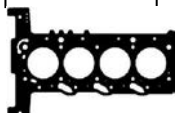



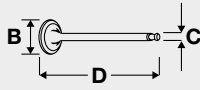

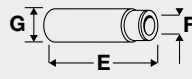





**NF817**  
36.00x50.00x7.00mm FPM



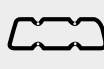









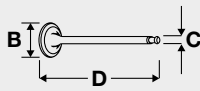

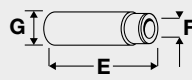









**BY310**

<b>516</b>  <b>86.00</b>		<b>Diesel</b>				
<b>4HV Euro 4 (D4)</b>	4 Cyl.	17.5:1	2198cc	<b>74kW (101)PS</b>	<b>Turbo Intercooled</b>	<b>TD20266 1182</b>
	B x C x D	OE	MAT.			E x F x G
<b>V98028</b> 	9 660 035 980		45°			
29.80 x 7.00 x 122.30						
<b>V98029</b> 	9 660 640 080		30°			
25.80 x 7.00 x 122.10						

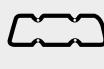
							
<b>AH6390</b> MLS, 1.100mm, 1 Notch	<b>CH6390</b> ▲					<b>HR5082</b> 	
<b>AH6400</b> MLS, 1.150mm, 2 Notches							
<b>AH6410</b> MLS, 1.200mm, 3 Notches							
							
<b>AH6390</b>	<b>AH6400</b>	<b>AH6410</b>					

<b>517</b>  <b>86.00</b>		<b>Petrol</b>					
<b>194 A1.000</b>	4 Cyl.	10:1	2198cc	<b>108kW (147)PS</b>		<b>TD18447 1174</b>	
	B x C x D	OE	MAT.			E x F x G	
<b>V94962</b> 	641 063		45°	H			
35.15 x 6.00 x 102.20							
<b>V94963</b> 	641 376		45°	ss H			
30.10 x 6.00 x 100.90							
							
<b>AG9580</b> MLS			<b>HBS416</b> 	<b>KG5337</b> 	<b>JM7102</b> (Elastomer)		
			M11x1.50x163.00mm (x10)	(MVQ)			
				<b>JD5868</b> 			

<b>518</b>  <b>86.00</b>		<b>Petrol</b>					
<b>939 A5.000</b>	4 Cyl.	2198cc		<b>136kW (185)PS</b>		<b>TD18913 1174</b>	
	B x C x D	OE	MAT.			E x F x G	
<b>V94962</b> 	641 063		45°	H			
35.15 x 6.00 x 102.20							
<b>V98003</b> 	55192156		45°				
35.00 x 6.00 x 102.20							
<b>V94963</b> 	641 376		45°	ss H			
30.10 x 6.00 x 100.90							
<b>V98004</b> 	71739686		45°				
30.00 x 6.00 x 100.10							
							
<b>AG9580</b> MLS					<b>KG5337</b> 		
					(MVQ)		
					<b>JD5868</b> 		

# FIAT GROUP

## 519

 86.40

Petrol



138 A1.000

4 Cyl.





9:1









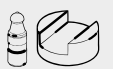

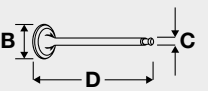

1301cc

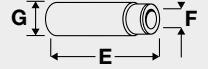









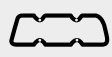

48kW (65)PS

TD4368

1184

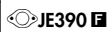
					
<b>TB114</b> 116x19		<b>CAM517</b>		<b>FOL104</b> (x8) [6]	
[6] Mechanical	[6] Mécanique	[6] Meccanico	[6] Mecánico		

				
B x C x D	OE	MAT.		E x F x G
<b>V34496</b> 	4 239 917		45°	<b>VAG92366</b> 
36.00 x 8.00 x 108.50		MB		46.50 x 8.00 x 14.10
<b>V90071</b> 	4 315 062		45°	
30.99 x 8.00 x 109.09		MD cr		
<b>V91713</b> 	4 315 062		45°	
31.00 x 8.00 x 109.00		MD cr		

							
<b>BP110</b> Fibre Composite	<b>DJ851</b>  <b>DP110</b>		<b>HBS051</b>  M10x1.25x98.00mm (x5)	<b>JD146</b>  <b>JE390</b> 	<b>JM663</b>  <b>JN805</b> 		<b>NA5187</b> 30.00x52.00x7.00mm ACM



BP110

## 520

 86.40

Petrol



138 A3.000

4 Cyl.







9:1











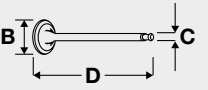

1301cc

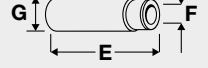









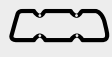

55kW (75)PS

TD4362

1184

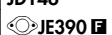

					
<b>TB114</b> 116x19		<b>CAM517</b>		<b>FOL104</b> (x8) [6]	
[6] Mechanical	[6] Mécanique	[6] Meccanico	[6] Mecánico		







				
B x C x D	OE	MAT.		E x F x G
<b>V34496</b> 	4 239 917		45°	<b>VAG92366</b> 
36.00 x 8.00 x 108.50		MB		46.50 x 8.00 x 14.10
<b>V90071</b> 	4 315 062		45°	
30.99 x 8.00 x 109.09		MD cr		
<b>V91713</b> 	4 315 062		45°	
31.00 x 8.00 x 109.00		MD cr		





							
<b>BP110</b> Fibre Composite	<b>DJ851</b>  <b>DP110</b>		<b>HBS051</b>  M10x1.25x98.00mm (x5)	<b>JD146</b>  <b>JE390</b> 	<b>JM663</b>  <b>JN805</b> 	<b>HR596</b> 	<b>NA5187</b> 30.00x52.00x7.00mm ACM





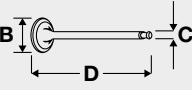
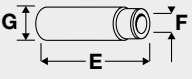





BP110

<b>521</b>	 <b>86.40</b>	<b>Petrol</b>	
146 A5.000	4 Cyl.	9.3:1	1301cc
			49kW (67)PS
			TD4376 <b>1185</b>

					
<b>TB247</b>					
120x15					

			
B x C x D	OE	MAT.	
<b>V90398</b> 	4 412 816		45° H
36.60 x 7.98 x 110.50		MB	
<b>V90399</b> 	4 340 119		45°
29.10 x 7.99 x 110.50		MD	

							
<b>BP290</b> Fibre Composite	<b>DP293</b>	<b>GK590</b>		<b>JD5155</b> (x2)	<b>JN283</b>	<b>HR596</b> 	<b>NA5187</b> 30.00x52.00x7.00mm ACM



BP290

**522**

**86.40**

**Petrol**



149 A3.000

4 Cyl.

9.1:1

1301cc

48kW (65)PS

TD958

1186

<p><b>TB126</b> 118x19 →7211446 for vehicles with automatic transmission</p> <p><b>TB248</b> 118x15 7211447→ for vehicles with air conditioning</p> <p><b>TB114</b> 116x19 Eng.→5771822 for vehicles without air conditioning; for vehicles with manual transmission</p>						<p><b>FOL104 (x8) [6]</b></p>

[6] Mechanical

[6] Mécanique

[6] Meccanico

[6] Mecánico

<p><b>V34496</b> ■ 36.00 x 8.00 x 108.50</p> <p><b>V90071</b> ■ 30.99 x 8.00 x 109.09</p> <p><b>V91713</b> ■ 31.00 x 8.00 x 109.00</p>	<p><b>VAG92366</b> ■ ■ ■ 46.50 x 8.00 x 14.10</p>
<p>OE: 4 239 917</p> <p>MAT: MB, MD cr, MD cr</p> <p>Angle: 45°, 45°, 45°</p> <p>Other: H</p>	

<p><b>BP860</b> Fibre Composite</p>	<p><b>DJ851</b> ▲ <b>DP871</b> →Eng.5750056</p>	<p><b>GP871</b> →Eng.5750056</p>	<p><b>HBS051</b> △ M10x1.25x98.00mm (x5)</p>	<p><b>JD146</b> <b>JE390</b> ■</p>	<p><b>JP049</b> ■ (Cork) <b>JN805</b> ■</p>	<p><b>HR596</b> ■</p>	<p><b>NA5187</b> 30.00x52.00x7.00mm ACM</p>



BP860

<b>523</b>	<b>86.40</b>	<b>Petrol</b>			
<b>831 A2.000</b>	4 Cyl.	9.5:1	1301cc	<b>55-58kW (75-79)PS</b>	<b>TD4605 1187</b>
<b>TB114</b> 116x19					<b>FOL104 (x8) [6]</b>
[6] Mechanical	[6] Mécanique	[6] Meccanico	[6] Mecánico		

B x C x D	OE	MAT.
<b>V34496</b>	4 239 917	45° H
36.00 x 8.00 x 108.50		
<b>V90071</b>	4 315 062	45°
30.99 x 8.00 x 109.09		
<b>V91713</b>	4 315 062	45°
31.00 x 8.00 x 109.00		
		<b>VAG92366</b>
		46.50 x 8.00 x 14.10

<b>BP110</b> Fibre Composite			<b>HBS051</b>	<b>JD146</b>	<b>JN805</b>	<b>HR596</b>	
			M10x1.25x98.00mm (x5)				



BP110

<b>524</b>	<b>86.40</b>	<b>Petrol</b>			
<b>831 B.000</b>	4 Cyl.	9.5:1	1301cc	<b>55kW (75)PS</b>	<b>TD1809 1187</b>
<b>TB114</b> 116x19 →07/85					<b>FOL104 (x8) [6]</b>
[6] Mechanical	[6] Mécanique	[6] Meccanico	[6] Mecánico		

B x C x D	OE	MAT.
<b>V34496</b>	4 239 917	45° H
36.00 x 8.00 x 108.50		
<b>V91713</b>	4 315 062	45°
31.00 x 8.00 x 109.00		
		<b>VAG92366</b>
		46.50 x 8.00 x 14.10

<b>BP110</b> Fibre Composite				<b>JD146</b>	<b>JM663</b>	<b>HR363</b>	



BP110

# FIAT GROUP





**525**

 **86.40**





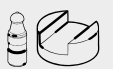

**Petrol**

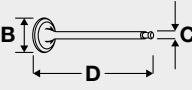
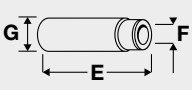

**138 A.000**      4 Cyl.      9.1:1      1302cc      **37-48kW (50-65)PS**      **TD18855**      **1183**

			 <b>KIT</b>		
					<b>FOL104 (x8) [6]</b>

[6] Mechanical      [6] Mécanique      [6] Meccanico      [6] Mecánico

			
B x C x D	OE	MAT.	Ex F x G
<b>V34496</b> 	4 239 917		<b>VAG92366</b> 
36.00 x 8.00 x 108.50		MB	46.50 x 8.00 x 14.10
<b>V91713</b> 	4 315 062		
31.00 x 8.00 x 109.00		MD cr	
		45°	
		45°	
		H	

**526**

 **86.40**

**Petrol**









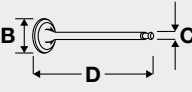
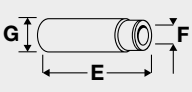

**138 B2.000**      4 Cyl.      9.1:1      1302cc      **50-51kW (68-69)PS**      **TD4363**      **1188**

**149 A7.000**      4 Cyl.      9.6:1      1302cc      **48kW (65)PS**      **TD4382**      **1188**









			 <b>KIT</b>		
--	---	---	--	--	---

<b>TB126</b> 118x19 →08/86 for vehicles with air conditioning					<b>FOL104 (x8) [6]</b>
<b>TB248</b> 118x15 for vehicles with air conditioning					
<b>TB114</b> 116x19 for vehicles without air conditioning					

[6] Mechanical      [6] Mécanique      [6] Meccanico      [6] Mecánico

			
B x C x D	OE	MAT.	Ex F x G
<b>V34496</b> 	4 239 917		<b>VAG92366</b> 
36.00 x 8.00 x 108.50		MB	46.50 x 8.00 x 14.10
<b>V90071</b> 	4 315 062		
30.99 x 8.00 x 109.09		MD cr	
<b>V91713</b> 	4 315 062		
31.00 x 8.00 x 109.00		MD cr	
		45°	
		45°	
		H	

							
---	---	---	---	---	--	---	---

<b>BP860</b> Fibre Composite	<b>DJ851</b>  →Eng.5750056 <b>DP871</b> →Eng.5750056	 <b>GP871</b> →Eng.5750056	<b>HBS051</b>  M10x1.25x98.00mm (x5)	<b>JD146</b>  <b>JE390</b> 	<b>JP049</b>  (Cork) <b>JN805</b> 	<b>HR596</b> 	<b>NA5187</b> 30.00x52.00x7.00mm ACM
------------------------------	--	--	--	--	--	--	---



BP860



<b>527</b>	<b>86.40</b>	<b>Petrol</b>				
<b>138 A2.000</b>	4 Cyl.	9:1	1498cc	<b>55-57kW (75-78)PS</b>	<b>TD916</b>	<b>1191</b>
<b>TB248</b> 118x15 for vehicles with air conditioning <b>TB126</b> 118x19 for vehicles without air conditioning		<b>CAM517</b>				<b>FOL104 (x8) [6]</b>
[6] Mechanical	[6] Mécanique	[6] Meccanico	[6] Mecánico			

B x C x D	E x F x G
OE	
MAT.	
<b>V34496</b>	<b>VAG92366</b>
4 239 917	46.50 x 8.00 x 14.10
36.00 x 8.00 x 108.50	
<b>V91762</b>	
4 403 047	
33.00 x 8.00 x 109.00	

<b>BP110</b> Fibre Composite	<b>DP110</b> 01/79→06/82 →Eng.4525272	<b>GP861</b>	<b>HBS051</b> M10x1.25x98.00mm (x5)	<b>JD146</b> <b>JE390</b>	<b>JM663</b> <b>JN805</b>	<b>HR596</b>	<b>NA5187</b> 30.00x52.00x7.00mm ACM



BP110

<b>528</b>	<b>86.40</b>	<b>Petrol</b>				
<b>138 A4.000</b>	4 Cyl.	9.2:1	1498cc	<b>63kW (86)PS</b>	<b>TD4357</b>	<b>1191</b>
<b>TB126</b> 118x19 <b>TB248</b> 118x15		<b>CAM517</b>				<b>FOL104 (x8) [6]</b>
[6] Mechanical	[6] Mécanique	[6] Meccanico	[6] Mecánico			

B x C x D	E x F x G
OE	
MAT.	
<b>V34496</b>	<b>VAG92366</b>
4 239 917	46.50 x 8.00 x 14.10
36.00 x 8.00 x 108.50	
<b>V91762</b>	
4 403 047	
33.00 x 8.00 x 109.00	

<b>BP110</b> Fibre Composite	<b>DP110</b> →Eng.4525272	<b>HBS051</b> M10x1.25x98.00mm (x5)	<b>JD146</b> <b>JE390</b>	<b>JM663</b> <b>JN805</b>	<b>HR596</b>	<b>NA5187</b> 30.00x52.00x7.00mm ACM



BP110

**529**

**86.40**

**Petrol**



138 B3.000

4 Cyl.

9.2:1

1498cc

55-61kW (75-83)PS

TD4365

1191

<b>TB126</b> 118x19 →08/86 for vehicles with air conditioning		<b>CAM517</b>		<b>FOL104 (x8) [6]</b>
<b>TB248</b> 118x15 →08/86 for vehicles with air conditioning				

[6] Mechanical      [6] Mécanique      [6] Meccanico      [6] Mecánico

<b>V34496</b> ■ 36.00 x 8.00 x 108.50	OE 4 239 917	MAT. 45°	H	<b>VAG92366</b> ■ ■ ■ 46.50 x 8.00 x 14.10
<b>V91762</b> ■ 33.00 x 8.00 x 109.00	OE 4 403 047	MAT. 45°		







<b>BP860</b> Fibre Composite	<b>DP860</b>	<b>GP861</b>	<b>HBS051</b> ⚠ M10x1.25x98.00mm (x5)	<b>JD146</b> JE390	<b>JP049</b> ■ (Cork) JN805 ■	<b>HR596</b> ■	<b>NA5187</b> 30.00x52.00x7.00mm ACM











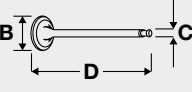

BP860











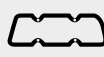

**530**  **86.40** **Petrol** 

138 B3.048 4 Cyl. 9:1 1498cc 55-57kW (75-78)PS TD4364 1193

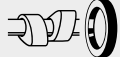
					
<b>TB126</b> 118x19		<b>CAM517</b>			<b>FOL104 (x8) [6]</b>
<b>TB248</b> 118x15					

[6] Mechanical [6] Mécanique [6] Meccanico [6] Mecánico

					
B x C x D	MAT.	45°	H		E x F x G
<b>V34496</b> 	4 239 917				<b>VAG92366</b> 
36.00 x 8.00 x 108.50		MB			46.50 x 8.00 x 14.10
<b>V91762</b> 	4 403 047		45°		
33.00 x 8.00 x 109.00		MD			



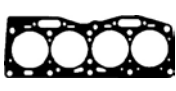



							
<b>BP860</b> Fibre Composite	<b>DP861</b>	<b>GP861</b>	<b>HBS011</b>  M12x1.25x119.00mm (x12)	<b>JD146</b>  <b>JE390</b>	<b>JP049</b>  (Cork) <b>JN805</b> 	<b>HR596</b> 	<b>NA5187</b> 30.00x52.00x7.00mm ACM













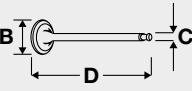

BP860

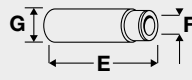







**531**  **86.40** **Petrol** 

138 C2.048 4 Cyl. 9:1 1498cc 55kW (75)PS TD5424 1190

					
<b>TB126</b> 118x19					<b>FOL104 (x8) [6]</b>
→07/89					

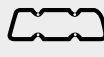
[6] Mechanical [6] Mécanique [6] Meccanico [6] Mecánico

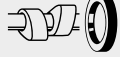
					
B x C x D	MAT.	45°	H		E x F x G
<b>V34496</b> 	4 239 917				<b>VAG92366</b> 
36.00 x 8.00 x 108.50		MB			46.50 x 8.00 x 14.10
<b>V90397</b> 	4 319 339		45° ss		
33.10 x 7.99 x 109.00		MD cr			
<b>V91762</b> 	4 403 047		45°		
33.00 x 8.00 x 109.00		MD			

							
					<b>JP049</b>  (Cork)		
					<b>JN805</b> 		

**532**

 **86.40**

**Petrol**



138 C3.048







4 Cyl.









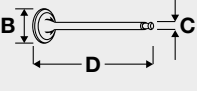

1498cc



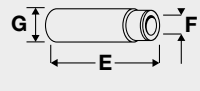









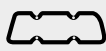

55-57kW (75-78)PS

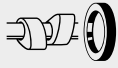
TD4366

**1194**









					
<b>TB126</b> 118x19					
<b>TB248</b> 118x15					









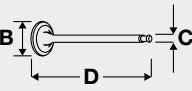

					
B x C x D	OE	MAT.	45°	H	E x F x G
<b>V34496</b> 	4 239 917		45°	H	<b>VAG92366</b> 
36.00 x 8.00 x 108.50		MB			46.50 x 8.00 x 14.10
<b>V91762</b> 	4 403 047		45°		
33.00 x 8.00 x 109.00		MD			

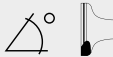

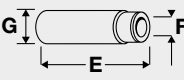









							
<b>BP110</b> Fibre Composite	<b>DP110</b> 01/79→06/82 →Eng.4525272	<b>GP861</b>	<b>HBS052</b>  M9x1.25x95.00mm (x10)	<b>JD146</b>  <b>JE390</b> 	<b>JM663</b>  <b>JP049</b>  (Cork) <b>JN805</b> 	<b>HR596</b> 	<b>NA5187</b> 30.00x52.00x7.00mm ACM

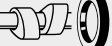

BP110

<b>533</b>	 <b>86.40</b>	<b>Petrol</b>			
149 A5.000	4 Cyl.	9.2:1	1498cc	58kW (79)PS	TD4381 <b>1194</b>
					
<b>TB126</b> 118x19 →08/86 for vehicles with air conditioning					<b>FOL104 (x8) [6]</b>
<b>TB248</b> 118x15 →08/86 for vehicles with air conditioning					
[6] Mechanical	[6] Mécanique	[6] Meccanico	[6] Mecánico		

					
B x C x D	OE	MAT.	45°	H	E x F x G
<b>V34496</b> 	4 239 917		45°	H	<b>VAG92366</b> 
36.00 x 8.00 x 108.50		MB			46.50 x 8.00 x 14.10
<b>V91762</b> 	4 403 047		45°		
33.00 x 8.00 x 109.00		MD			

							
<b>BP860</b> Fibre Composite	<b>DP860</b>	<b>GP861</b>	<b>HBS011</b>  M12x1.25x119.00mm (x12) <b>HBS051</b>  M10x1.25x98.00mm (x5)	<b>JD146</b>  <b>JE390</b>	<b>JP049</b>  (Cork) <b>JN805</b> 	<b>HR596</b> 	<b>NA5187</b> 30.00x52.00x7.00mm ACM



BP860

**534**

 **86.40**

**Petrol**



831 A1.000

4 Cyl.

9.2:1

1498cc

63kW (86)PS

TD1805

**1195**



**TB126**  
118x19

**FOL104** (x8) [6]

[6] Mechanical

[6] Mécanique

[6] Meccanico

[6] Mecánico

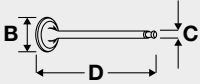

B x C x D

OE



MAT.



45°

ss

H

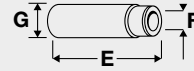

E x F x G

**V34496** ■  
36.00 x 8.00 x 108.50

4 239 917

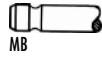

MB

45°

H

**VAG92366** ■ ■ ■  
46.50 x 8.00 x 14.10



**V90397** ■  
33.10 x 7.99 x 109.00

4 319 339

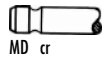

MD cr

45°

ss

**V91762** ■  
33.00 x 8.00 x 109.00

4 403 047

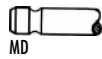

MD

45°

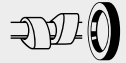
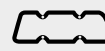

**BP860** Fibre Composite



**DP860**

**GP861**







**HBS051** △  
M10x1.25x98.00mm (x5)













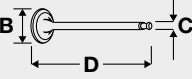

**BP860**

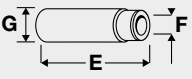







**535**  **86.40** **Petrol** 

831 B1.000 4 Cyl. 9.2:1 1498cc 59-63kW (80-86)PS TD1811 1192

					
<b>TB126</b> 118x19 →07/89				<b>FOL104</b> (x8) [6]	

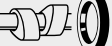

[6] Mechanical [6] Mécanique [6] Meccanico [6] Mecánico

 B x C x D	OE	MAT.				 E x F x G
<b>V34496</b> 	4 239 917		45°		H	<b>VAG92366</b>  46.50 x 8.00 x 14.10
36.00 x 8.00 x 108.50		MB				
<b>V90397</b> 	4 319 339		45°	ss		
33.10 x 7.99 x 109.00		MD cr				
<b>V91762</b> 	4 403 047		45°			
33.00 x 8.00 x 109.00		MD				







							
<b>BP860</b> Fibre Composite	<b>DP871</b> →Eng.5750056 <b>DJ851</b> ▲ Eng.5750056→ <b>DP861</b> Eng.5750056→	<b>GP861</b>	<b>HBS051</b> ▲ M10x1.25x98.00mm (x5)		<b>JP049</b>  (Cork) <b>JN805</b> 		













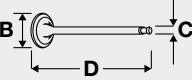

BP860

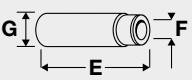
**536**  **86.40** **Petrol** 

831 B1.048 4 Cyl. 1498cc 55kW (75)PS TD1810 1192

					
<b>TB126</b> 118x19 →07/89				<b>FOL104</b> (x8) [6]	

[6] Mechanical [6] Mécanique [6] Meccanico [6] Mecánico

 B x C x D	OE	MAT.				 E x F x G
<b>V34496</b> 	4 239 917		45°		H	<b>VAG92366</b>  46.50 x 8.00 x 14.10
36.00 x 8.00 x 108.50		MB				
<b>V90397</b> 	4 319 339		45°	ss		
33.10 x 7.99 x 109.00		MD cr				
<b>V91762</b> 	4 403 047		45°			
33.00 x 8.00 x 109.00		MD				

# FIAT GROUP

<b>537</b>	86.40	<b>Petrol</b>				
138 AS.000	4 Cyl.	9:1	1499cc	63kW (85)PS	TD4359	1192
					JM663	

<b>538</b>	86.40	<b>Petrol</b>				
138 C2.048	4 Cyl.	9:1	1499cc	55kW (75)PS	TD926	1196
<b>TB126</b> 118x19 →12/88 <b>TB305</b> 138x15 01/89→	<b>TBK027</b> 01/89→ Component No: TB305; AE1008TP		<b>KIT</b>			<b>FOL104</b> (x8) [6]
[6] Mechanical	[6] Mécanique	[6] Meccanico	[6] Mecánico			

	OE	MAT.			
<b>V34496</b> 36.00 x 8.00 x 108.50	4 239 917		45°	H	<b>VAG92366</b> 46.50 x 8.00 x 14.10
<b>V91762</b> 33.00 x 8.00 x 109.00	4 403 047		45°		

<b>BP860</b> Fibre Composite	<b>DJ851</b> ▲ <b>DP860</b>	<b>GP861</b>	<b>HBS011</b> Ⓞ M12x1.25x119.00mm (x12)	<b>JD146</b> <b>JE390</b>	<b>JP049</b> (Cork) <b>JN805</b>	<b>HR596</b>	<b>NA5187</b> 30.00x52.00x7.00mm ACM



BP860



<b>539</b>	<b>86.40</b>	<b>Petrol</b>			
<b>149 C1.000</b>	4 Cyl.	9.2:1	1499cc	<b>49-55kW (67-75)PS</b>	<b>TD973 1197</b>
<b>TB126</b> 118x19 →12/88 <b>TB305</b> 138x15 01/89→	<b>TBK027</b> 01/89→ Component No: TB305; AE1008TP				<b>FOL104 (x8) [6]</b>
[6] Mechanical	[6] Mécanique	[6] Meccanico	[6] Mecánico		

B x C x D	OE	MAT.	45°	H	Ex F x G
<b>V34496</b>	4 239 917		45°	H	<b>VAG92366</b>
36.00 x 8.00 x 108.50		MB			46.50 x 8.00 x 14.10
<b>V91762</b>	4 403 047		45°		
33.00 x 8.00 x 109.00		MD			

<b>BP860</b> Fibre Composite	<b>DP861</b> Eng.5750056→	<b>GP861</b>	<b>HBS011</b> M12x1.25x119.00mm (x12)	<b>JD146</b> <b>JE390</b>	<b>JP049</b> (Cork) <b>JN805</b>	<b>HR596</b>	<b>NA5187</b> 30.00x52.00x7.00mm ACM



BP860

<b>540</b>	<b>86.40</b>	<b>Petrol</b>			
<b>146 C6.000</b>	4 Cyl.	19.5:1	1581cc	<b>55kW (75)PS</b>	<b>TD954 1198</b>
<b>146 D6.000</b>	4 Cyl.	9.2:1	1581cc	<b>55kW (75)PS</b>	<b>TD959 1198</b>
<b>TB305</b> 138x15	<b>TBK027</b> Component No: TB305; AE1008TP				<b>FOL104 (x8) [6]</b>
[6] Mechanical	[6] Mécanique	[6] Meccanico	[6] Mecánico		
<b>AY460</b> Fibre Composite	<b>DR630</b>	<b>HBS051</b> M10x1.25x98.00mm (x5)	<b>JP049</b> (Cork) <b>JN805</b>	<b>NA5187</b> 30.00x52.00x7.00mm ACM	



AY460

# FIAT GROUP

## 541



86.40

Petrol



159 A3.000

4 Cyl.

9.2:1

1581cc

62-66kW (84-90)PS

TD9787

1199

<b>TB305</b> 138x15	<b>TBK027</b> Component No: TB305; AE1008TP		<b>KIT</b>		<b>FOL104 (x8) [6]</b>

[6] Mechanical [6] Mécanique [6] Meccanico [6] Mecánico

B x C x D	E x F x G
<b>V91300</b> ■ 37.50 x 8.00 x 108.50	<b>VAG92366</b> ■ ■ 46.50 x 8.00 x 14.10
<b>V91762</b> ■ 33.00 x 8.00 x 109.00	

<b>AY460</b> Fibre Composite	<b>DR630</b>	<b>GT446</b> [1] 01/91→	<b>HBS051</b> △ M10x1.25x98.00mm (x5)	<b>JD146</b> <b>JA757</b> ■	<b>JP049</b> ■ (Cork) <b>JN805</b> ■	<b>HR363</b> ■	<b>NA5187</b> 30.00x52.00x7.00mm ACM



**AY460**  
[1] Without crankshaft seal [1] sans bague d'étanchéité - vilebrequin [1] senza paraolio-albero a gomiti [1] sin cigüeñal retén

## 542



86.40

Petrol



159 A3.046

4 Cyl.

9.2:1

1581cc

57-65kW (78-88)PS

TD1006

1199

<b>TB305</b> 138x15	<b>TBK027</b> Component No: TB305; AE1008TP		<b>KIT</b>		<b>FOL104 (x8) [6]</b>

[6] Mechanical [6] Mécanique [6] Meccanico [6] Mecánico

B x C x D	E x F x G
<b>V91300</b> ■ 37.50 x 8.00 x 108.50	<b>VAG92366</b> ■ ■ 46.50 x 8.00 x 14.10
<b>V91762</b> ■ 33.00 x 8.00 x 109.00	

<b>AY460</b> Fibre Composite <b>BR630</b> Fibre Composite	<b>DR630</b>	<b>GR630</b>	<b>HBS051</b> △ M10x1.25x98.00mm (x5) 01/93→	<b>JD146</b>	<b>JP049</b> ■ (Cork) <b>JN805</b> ■	<b>HR363</b> ■	<b>NA5187</b> 30.00x52.00x7.00mm ACM



**AY460, BR630**

<b>543</b>	<b>86.40</b>	<b>Petrol</b>			
<b>159 A3.048</b>	4 Cyl.	9.2:1	1581cc	<b>51-66kW (69-90)PS</b>	<b>TD1007 1200</b>
<b>TB305</b> 138x15	<b>TBK027</b> Component No: TB305; AE1008TP	<b>CAM719</b>			<b>FOL104 (x8) [6]</b>

[6] Mechanical [6] Mécanique [6] Meccanico [6] Mecánico

B x C x D	E x F x G
<b>V91300</b>	<b>VAG92366</b>
37.50 x 8.00 x 108.50	46.50 x 8.00 x 14.10
<b>V91762</b>	
33.00 x 8.00 x 109.00	
OE: 7 609 772	
MAT.:	
45°	H

<b>AY460</b> Fibre Composite <b>BR630</b> Fibre Composite	<b>DR630</b>	<b>GR630</b>	<b>HBS051</b> M10x1.25x98.00mm (x5) 01/93→	<b>JD146</b> <b>JF150</b>	<b>JP049</b> (Cork) <b>JN805</b>	<b>HR363</b>	<b>NA5187</b> 30.00x52.00x7.00mm ACM



AY460, BR630

<b>544</b>	<b>86.40</b>	<b>Petrol</b>					
<b>159 B9.000</b>	4 Cyl.	1581cc	<b>66kW (90)PS</b>	<b>TD4598 1201</b>			
<b>TB305</b> 138x15 →08/97	<b>TBK027</b> →08/97 Component No: TB305; AE1008TP				<b>FOL104 (x8) [6]</b>		
[6] Mechanical	[6] Mécanique	[6] Meccanico	[6] Mecánico				
					<b>JP049</b> (Cork) <b>JN805</b>		

# FIAT GROUP

## 545

### 86.40

### Petrol



159 B9.000

4 Cyl.

1581cc

63-66kW (86-90)PS

TD965

1202

<b>TB305</b> 138x15	<b>TBK027</b> Component No: TB305; AE1008TP				<b>FOL104</b> (x8) [6] →12/95

[6] Mechanical

[6] Mécanique

[6] Meccanico

[6] Mecánico

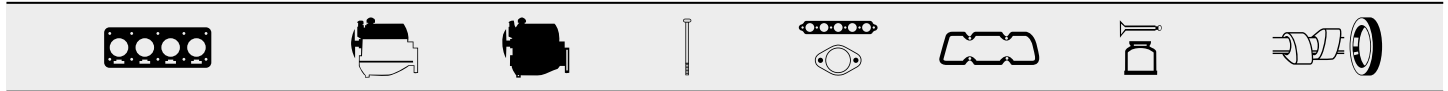

AY460 Fibre Composite  
BR630 Fibre Composite

DR631

HBS051   
M10x1.25x98.00mm (x5)

JD146

JP024

HR363

NA5187  
30.00x52.00x7.00mm ACM



AY460, BR630

## 546

### 86.40

### Petrol



160 A2.000

4 Cyl.

9.2:1

1581cc

58-62kW (79-84)PS

TD1019

1203

<b>TB305</b> 138x15	<b>TBK027</b> Component No: TB305; AE1008TP				<b>FOL104</b> (x8) [6]

[6] Mechanical

[6] Mécanique

[6] Meccanico

[6] Mecánico

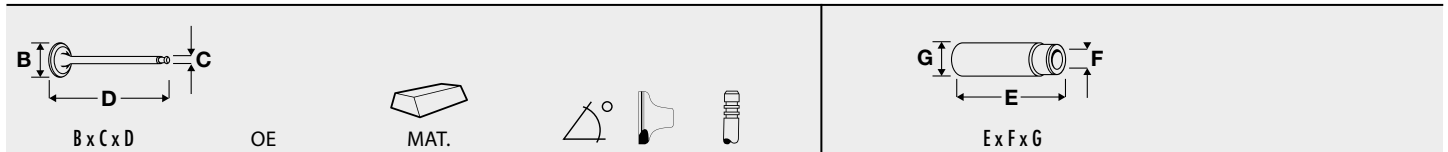

**V91300**   
37.50 x 8.00 x 108.50  
**V91762**   
33.00 x 8.00 x 109.00

OE

MAT.

45°

H

**VAG92366**   
46.50 x 8.00 x 14.10

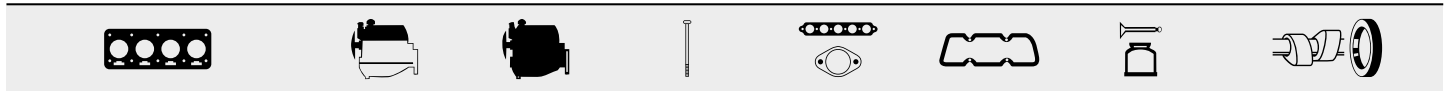
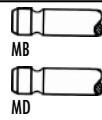

AY460 Fibre Composite  
BR630 Fibre Composite

DP689  
→12/90  
DT446  
01/91→

**GT446** [1]  
01/91→

HBS051   
M10x1.25x98.00mm (x5)

JA757

JN643  
JP049   
(Cork)  
JN805

HR569

NA5187  
30.00x52.00x7.00mm ACM



AY460, BR630

[1] Without crankshaft seal







[1] sans bague d'étanchéité - vilebrequin

[1] senza paraolio-albero a gomiti









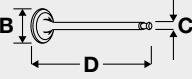

[1] sin cigüeñal retén



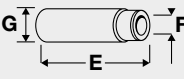









**547**  **86.40** **Petrol** 

176 A9.000 4 Cyl. 9.5:1 1581cc **65kW (88)PS** TD1039 **1204**

					
<b>TB305</b> 138x15	<b>TBK027</b> Component No: TB305; AE1008TP				<b>FOL104</b> (x8) [6]

[6] Mechanical [6] Mécanique [6] Meccanico [6] Mecánico

	OE				
<b>V91306</b>  39.50 x 8.00 x 108.50	7 617 500	 MB	45°	H	<b>VAG92366</b>  46.50 x 8.00 x 14.10
<b>V91713</b>  31.00 x 8.00 x 109.00	4 315 062	 MD cr	45°		









							
<b>AY460</b> Fibre Composite <b>BR630</b> Fibre Composite	<b>DR631</b>		<b>HBS051</b>  M10x1.25x98.00mm (x5)	<b>JD146</b>	<b>JP049</b>  (Cork) <b>JN805</b> 	<b>HR363</b> 	<b>NA5187</b> 30.00x52.00x7.00mm ACM











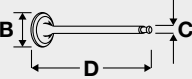



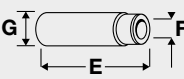

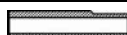









AY460, BR630

**548**  **86.40** **Petrol** 

178 B3.000 4 Cyl. 10.15:1 1581cc **74-78kW (100-106)PS** TD10187 **1205**

					
<b>TB471</b> 158x25.4	<b>TBK089</b> Component No: TB471; AE1086TP;AE1085GP	<b>CAM709</b>  <b>CAM710</b> 			<b>FOL106</b> (x16) Height: 24mm <b>FOL145</b> (x16) Height: 26mm

	OE				
<b>V91949</b>  30.40 x 7.00 x 102.00	46 517 325	 MB cr	45°	H	<b>VAG92364</b>  42.50 x 7.00 x 13.07
<b>V91950</b>  29.80 x 7.00 x 102.60	46 462 159	 MD cr	45°		<b>VAG96123</b>  42.25 x 7.02 x 13.05
<b>V94468</b>  30.00 x 7.00 x 102.40	46 461 209	 MG cr	45°	ss H	<b>VAG96146</b>  42.50 x 7.04 x 13.05

							
<b>BX030</b> Fibre Composite, 1.650mm <b>AY470</b> Fibre Composite, 1.850mm	<b>CY470</b> →09/99 <b>DX030</b> →09/99	 <b>GX030</b> →Eng.9508753	<b>HBS131</b>  M10x1.25x100.00mm (x10)	<b>JD5143</b> 	<b>JN973</b>	<b>HR800</b> 	<b>NA5187</b> 30.00x52.00x7.00mm ACM



BX030, AY470

# FIAT GROUP

<b>549</b>	86.40	<b>Petrol</b>			
178 C7.098	4 Cyl.	1581cc	68-76kW (92-103)PS		TD18896 <b>1206</b>
	.KIT		KIT		
					<b>FOL106</b> (x16) Height: 24mm <b>FOL145</b> (x16) Height: 26mm

<b>BX030</b> Fibre Composite, 1.650mm <b>AY470</b> Fibre Composite, 1.850mm	<b>CY470</b> <b>DX030</b>	<b>GX030</b>	<b>HBS131</b> M10x1.25x100.00mm (x10)	<b>HA5005</b> <b>JD5143</b>	<b>JN973</b>	<b>HR800</b>	<b>NA5187</b> 30.00x52.00x7.00mm ACM



BX030, AY470

<b>550</b>	86.40	<b>Petrol</b>				
178 D2.011	4 Cyl.	10.5:1	1581cc	68-76kW (92-103)PS		TD18897 <b>1207</b>
	.KIT		KIT			
						<b>FOL106</b> (x16) Height: 24mm <b>FOL145</b> (x16) Height: 26mm

<b>BX030</b> Fibre Composite, 1.650mm <b>AY470</b> Fibre Composite, 1.850mm	<b>CY470</b> <b>DX030</b>	<b>GX030</b>	<b>HBS131</b> M10x1.25x100.00mm (x10)	<b>HA5005</b> <b>JD5143</b>	<b>JN973</b>	<b>HR599</b>	



BX030, AY470

<b>551</b>	<b>86.40</b>	<b>Petrol</b>				
<b>182 A4.000</b>	4 Cyl.	10.5:1	1581cc	<b>76kW (103)PS</b>	<b>TD4400</b>	<b>1208</b>

<b>TB471</b> 158x25.4	<b>TBK089</b> Component No: TB471; AE1086TP;AE1085GP	<b>CAM709</b> ■ <b>CAM710</b> ■		<b>FOL106</b> (x16) Height: 24mm	<b>FOL145</b> (x16) Height: 26mm

B x C x D	OE	MAT.	45°	H	E x F x G
<b>V91949</b> ■ 30.40 x 7.00 x 102.00	46 517 325		45°	H	<b>VAG92364</b> ■ 42.50 x 7.00 x 13.07
<b>V91950</b> ■ 29.80 x 7.00 x 102.60	46 462 159		45°		<b>VAG96123</b> ■ 42.25 x 7.02 x 13.05
<b>V94468</b> ■ 30.00 x 7.00 x 102.40	46 461 209		45°	ss H	<b>VAG96146</b> ■ 42.50 x 7.04 x 13.05

<b>BX030</b> Fibre Composite, 1.650mm <b>AY470</b> Fibre Composite, 1.850mm	<b>CY470</b> <b>DX030</b>	<b>GX030</b>	<b>HBS131</b> ⊗ M10x1.25x100.00mm (x10)	<b>HA5005</b> ■ ■ ■ <b>JD5143</b> ■	<b>JN973</b>	<b>HR800</b> ■	<b>NA5187</b> 30.00x52.00x7.00mm ACM



BX030, AY470

<b>552</b>	<b>86.40</b>	<b>Petrol</b>				
<b>182 A4.000</b>	4 Cyl.	10.2:1	1581cc	<b>76kW (103)PS</b>	<b>TD9476</b>	<b>1209</b>
<b>182 A6.000</b>	4 Cyl.	10.1:1	1581cc	<b>66kW (90)PS</b>	<b>TD9475</b>	<b>1209</b>

<b>TB471</b> 158x25.4	<b>TBK089</b> Component No: TB471; AE1086TP;AE1085GP			<b>FOL106</b> (x16) Height: 24mm	<b>FOL145</b> (x16) Height: 26mm

B x C x D	OE	MAT.	45°	H	E x F x G
<b>V91949</b> ■ 30.40 x 7.00 x 102.00	46 517 325		45°	H	<b>VAG92364</b> ■ 42.50 x 7.00 x 13.07
<b>V91950</b> ■ 29.80 x 7.00 x 102.60	46 462 159		45°		<b>VAG96123</b> ■ 42.25 x 7.02 x 13.05
<b>V94468</b> ■ 30.00 x 7.00 x 102.40	46 461 209		45°	ss H	<b>VAG96146</b> ■ 42.50 x 7.04 x 13.05

<b>BX030</b> Fibre Composite, 1.650mm <b>AY470</b> Fibre Composite, 1.850mm	<b>CY470</b> <b>DX030</b>	<b>GX030</b>	<b>HBS131</b> ⊗ M10x1.25x100.00mm (x10)	<b>HA5005</b> ■ ■ ■ <b>JD5143</b> ■	<b>JN973</b>	<b>HR800</b> ■	<b>NA5187</b> 30.00x52.00x7.00mm ACM



BX030, AY470

# FIAT GROUP

**553**

**86.40**

**Petrol**



182 A6.000

4 Cyl.

10.1:1

1581cc

66kW (90)PS

TD4402

1210

<b>TB471</b> 158x25.4 →02/97	<b>TBK089</b> →02/97 Component No: TB471; AE1086TP;AE1085GP				<b>FOL106</b> (x16) Height: 24mm <b>FOL145</b> (x16) Height: 26mm

B x C x D	OE	MAT.			E x F x G
<b>V91949</b> ■ 30.40 x 7.00 x 102.00	46 517 325	 MB cr	45°	H	<b>VAG92364</b> ■ 42.50 x 7.00 x 13.07
<b>V91950</b> ■ 29.80 x 7.00 x 102.60	46 462 159	 MD cr	45°		<b>VAG96123</b> ■ 42.25 x 7.02 x 13.05
<b>V94468</b> ■ 30.00 x 7.00 x 102.40	46 461 209	 MG cr	45° ss	H	<b>VAG96146</b> ■ 42.50 x 7.04 x 13.05

<b>BX030</b> Fibre Composite, 1.650mm <b>AY470</b> Fibre Composite, 1.850mm	<b>CY470</b> DX030	<b>GX030</b> →Eng.9508753	<b>HBS131</b> ☒ M10x1.25x100.00mm (x10)	<b>HA5005</b> ■ ■ ■ JD5143 ■	<b>JN973</b>	<b>HR800</b> ■	<b>NA5187</b> 30.00x52.00x7.00mm ACM



BX030, AY470

**554**

**86.40**

**Petrol**



182 B5.098

4 Cyl.

10.5:1

1581cc

72kW (98)PS

TD19060

1206



					<b>FOL106</b> (x16) Height: 24mm <b>FOL145</b> (x16) Height: 26mm

<b>BX030</b> Fibre Composite, 1.650mm <b>AY470</b> Fibre Composite, 1.850mm	<b>CY470</b> DX030	<b>GX030</b>	<b>HBS131</b> ☒ M10x1.25x100.00mm (x10)	<b>HA5005</b> ■ ■ ■ JD5143 ■	<b>JN973</b>	<b>HR599</b> ■	<b>NA5187</b> 30.00x52.00x7.00mm ACM

















BX030, AY470

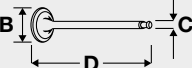



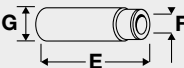



**555**  **86.40** **Petrol** 

**185 A3.000 Euro 3 (D3)** 4 Cyl. 10.1:1 1581cc **68-76kW (92-103)PS** **TD15650** **1208**

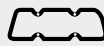

					
<b>TB471</b> 158x25.4 →08/00	<b>TBK089</b> →08/00 Component No: TB471; AE1086TP;AE1085GP	<b>CAM709</b> ■ <b>CAM710</b> ■			<b>FOL106</b> (x16) Height: 24mm <b>FOL145</b> (x16) Height: 26mm

 B x C x D	OE	MAT.				 E x F x G
<b>V91949</b> ■ 30.40 x 7.00 x 102.00	46 517 325	 MB cr	45°		H	<b>VAG92364</b> ■ 42.50 x 7.00 x 13.07
<b>V91950</b> ■ 29.80 x 7.00 x 102.60	46 462 159	 MD cr	45°			<b>VAG96123</b> ■ 42.25 x 7.02 x 13.05
<b>V94468</b> ■ 30.00 x 7.00 x 102.40	46 461 209	 MG cr	45°	ss	H	<b>VAG96146</b> ■ 42.50 x 7.04 x 13.05







							
<b>BX030</b> Fibre Composite, 1.650mm <b>AY470</b> Fibre Composite, 1.850mm	<b>CY470</b> <b>DX030</b>	<b>GX030</b> →Eng.9508753	<b>HBS131</b> ⊗ M10x1.25x100.00mm (x10)	<b>JD340</b> ■ <b>JD5143</b> ■	<b>JN973</b>	<b>HR599</b> ■	<b>NA5187</b> (x2) 30.00x52.00x7.00mm ACM











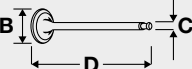



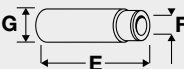

BX030, AY470

**556**  **86.40** **LPG** 

**186 A3.000** 4 Cyl. 12.5:1 1581cc **70kW (95)PS** **TD11787** **1211**

					
<b>TB471</b> 158x25.4 →08/05	<b>TBK089</b> →08/05 Component No: TB471; AE1086TP;AE1085GP	<b>CAM709</b> ■ <b>CAM710</b> ■			<b>FOL106</b> (x16) Height: 24mm <b>FOL145</b> (x16) Height: 26mm

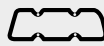
 B x C x D	OE	MAT.				 E x F x G
<b>V91949</b> ■ 30.40 x 7.00 x 102.00	46 517 325	 MB cr	45°		H	<b>VAG92364</b> ■ 42.50 x 7.00 x 13.07
<b>V91950</b> ■ 29.80 x 7.00 x 102.60	46 462 159	 MD cr	45°			<b>VAG96123</b> ■ 42.25 x 7.02 x 13.05
<b>V94468</b> ■ 30.00 x 7.00 x 102.40	46 461 209	 MG cr	45°	ss	H	<b>VAG96146</b> ■ 42.50 x 7.04 x 13.05

							
<b>BX030</b> Fibre Composite, 1.650mm <b>AY470</b> Fibre Composite, 1.850mm	<b>CY470</b> <b>DX030</b>	<b>GX030</b> →Eng.9508753	<b>HBS131</b> ⊗ M10x1.25x100.00mm (x10)	<b>JD340</b> ■ <b>JD5143</b> ■	<b>JN973</b>	<b>HR599</b> ■	<b>NA5187</b> 30.00x52.00x7.00mm ACM



BX030, AY470



186 A4.000

4 Cyl.

10.5:1

1581cc

68-76kW (92-103)PS

TD11788

1212

<b>TB471</b> 158x25.4 →09/03	<b>TBK089</b> →09/03 Component No: TB471; AE1086TP;AE1085GP	<b>CAM709</b> ■ <b>CAM710</b> ■	<b>FOL106</b> (x16) Height: 24mm <b>FOL145</b> (x16) Height: 26mm

	OE	MAT.		
B x C x D				E x F x G
<b>V91949</b> ■ 30.40 x 7.00 x 102.00	46 517 325		45° H	<b>VAG92364</b> ■ 42.50 x 7.00 x 13.07
<b>V91950</b> ■ 29.80 x 7.00 x 102.60	46 462 159		45°	<b>VAG96123</b> ■ 42.25 x 7.02 x 13.05
<b>V94468</b> ■ 30.00 x 7.00 x 102.40	46 461 209		45° ss H	<b>VAG96146</b> ■ 42.50 x 7.04 x 13.05

<b>BX030</b> Fibre Composite, 1.650mm <b>AY470</b> Fibre Composite, 1.850mm	<b>CY470</b> <b>DX030</b>	<b>GX030</b> →Eng.9508753	<b>HBS131</b> ☒ M10x1.25x100.00mm (x10)	<b>JD340</b> ■ <b>JD5143</b> ■	<b>JN973</b>	<b>HR599</b> ■	<b>NA5187</b> (x2) 30.00x52.00x7.00mm ACM



BX030, AY470

<b>558</b>	<b>86.40</b>	<b>Petrol</b>	
<b>220 A 2.000</b>	4 Cyl.	1581cc	<b>58kW (79)PS</b>
			<b>TD6826 1204</b>

<b>TB305</b> 138x15 →08/00	<b>TBK027</b> →08/00 Component No: TB305; AE1008TP		<b>KIT</b>		<b>FOL104 (x8) [6]</b>

[6] Mechanical      [6] Mécanique      [6] Meccanico      [6] Mecánico

<b>B x C x D</b>	<b>E x F x G</b>
<b>OE</b>	<b>MAT.</b>
<b>V91300</b>	45°
37.50 x 8.00 x 108.50	<b>H</b>
<b>V90071</b>	45°
30.99 x 8.00 x 109.09	
<b>V91713</b>	45°
31.00 x 8.00 x 109.00	
	<b>VAG92366</b>
	46.50 x 8.00 x 14.10

<b>AY460</b> Fibre Composite <b>BR630</b> Fibre Composite	<b>DR630</b> <b>DR632</b>	<b>HBS092</b> M10x1.25x115.00mm (x10) →12/92 <b>HBS051</b> M10x1.25x98.00mm (x5) 01/93→	<b>JD146</b> <b>JF150</b>	<b>JP049</b> (Cork) <b>JN805</b>	<b>HR363</b>	<b>NA5187</b> 30.00x52.00x7.00mm ACM



AY460, BR630

**559**

**86.40**

**Petrol**



835 A1.000

4 Cyl.

9.2:1

1581cc

65-66kW (88-90)PS

TD1842

1213

<b>TB305</b> 138x15	<b>TBK027</b> Component No: TB305; AE1008TP		<b>KIT</b>		<b>FOL104 (x8) [6]</b>



[6] Mechanical [6] Mécanique [6] Meccanico [6] Mecánico







<b>B x C x D</b>	<b>OE</b>	<b>MAT.</b>			<b>E x F x G</b>
<b>V91300</b>	7 609 772		45°	H	<b>VAG92366</b>
37.50 x 8.00 x 108.50		MB			46.50 x 8.00 x 14.10
<b>V90071</b>	4 315 062		45°		
30.99 x 8.00 x 109.09		MD cr			
<b>V91713</b>	4 315 062		45°		
31.00 x 8.00 x 109.00		MD cr			

<b>AY460</b> Fibre Composite <b>BR630</b> Fibre Composite	<b>DR632</b> →12/92 <b>DR630</b> 01/93→		<b>HBS092</b> M10x1.25x115.00mm (x10) →12/92 <b>HBS051</b> M10x1.25x98.00mm (x5) 01/93→		<b>JP049</b> (Cork) <b>JN805</b>	











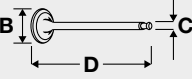
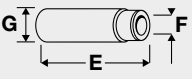









AY460, BR630

<b>560</b>	 <b>86.40</b>	<b>Petrol</b>	
<b>835 A1.046</b>	4 Cyl.	9.2:1	1581cc
			<b>57kW (77)PS</b>
			<b>TD1843 1214</b>

					
<b>TB305</b> 138x15	<b>TBK027</b> Component No: TB305; AE1008TP		<b>KIT</b>		<b>FOL104 (x8) [6]</b>

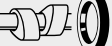
[6] Mechanical      [6] Mécanique      [6] Meccanico      [6] Mecánico

	
B x C x D	E x F x G
OE	
MAT.	
	
45°	
H	
<b>V91306</b> 	<b>VAG92366</b> 
39.50 x 8.00 x 108.50	46.50 x 8.00 x 14.10
<b>V90071</b> 	
30.99 x 8.00 x 109.09	
<b>V91713</b> 	
31.00 x 8.00 x 109.00	

							
<b>AY460</b> Fibre Composite	<b>DR630</b>	<b>HBS092</b>  M10x1.25x115.00mm (x10)		<b>JP049</b>  (Cork)	<b>JN805</b> 		



AY460

## 561

## 86.40

## Petrol



835 Cl.000

4 Cyl.

9.2:1

1581cc

55kW (75)PS

TD4611

1214

<b>TB305</b> 138x15 →08/97	<b>TBK027</b> →08/97 Component No: TB305; AE1008TP	<b>CAM719</b>		<b>FOL104 (x8) [6]</b>

[6] Mechanical

[6] Mécanique

[6] Meccanico



[6] Mecánico

<b>V91306</b> ■ 39.50 x 8.00 x 108.50	<b>V90071</b> ■ 30.99 x 8.00 x 109.09	<b>V91713</b> ■ 31.00 x 8.00 x 109.00	<b>VAG92366</b> ■ ■ ■ 46.50 x 8.00 x 14.10
B x C x D	OE	MAT.	E x F x G
		45°	
		45°	
		45°	







<b>AY460</b> Fibre Composite	<b>DR632</b>	<b>HBS051</b> △ M10x1.25x98.00mm (x5)	<b>JD146</b>	<b>JP049</b> ▣ (Cork) <b>JN805</b> ▣	<b>HR363</b> ■













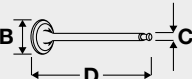

AY460

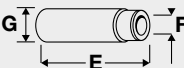











**562**  **86.40** **Petrol** 

**835 CI.000** 4 Cyl. 9.2:1 1581cc **55-57kW (75-78)PS** **TD1067** **1215**

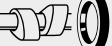
					
<b>TB305</b> 138x15	<b>TBK027</b> Component No: TB305; AE1008TP	<b>CAM719</b>			<b>FOL104 (x8) [6]</b>



[6] Mechanical [6] Mécanique [6] Meccanico [6] Mecánico

				
B x C x D	OE	MAT.		E x F x G
<b>V91306</b> 	7 617 500		45°	<b>VAG92366</b> 
39.50 x 8.00 x 108.50		MB		46.50 x 8.00 x 14.10
<b>V90071</b> 	4 315 062		45°	
30.99 x 8.00 x 109.09		MD cr		
<b>V91713</b> 	4 315 062		45°	
31.00 x 8.00 x 109.00		MD cr		







							
<b>AY460</b> Fibre Composite <b>BR630</b> Fibre Composite	<b>DR630</b> →12/93	<b>GR630</b>	<b>HBS051</b>  M10x1.25x98.00mm (x5)	<b>JD146</b>  <b>JF150</b>	<b>JP049</b>  (Cork) <b>JN805</b> 	<b>HR363</b>  <b>HR569</b> 	<b>NA5187</b> 30.00x52.00x7.00mm ACM











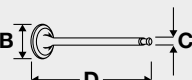

AY460, BR630



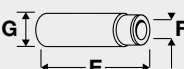





**563**  **87.00** **Petrol** 

**AR 30550** 4 Cyl. 9.5:1 1712cc **84-95kW (114-129)PS** **TD4186** **1216**

					
<b>TB106</b> 98x17 →12/88	<b>TBK287</b> 01/89→ Component No: TB338; AE1006TP;AE1007TP	<b>TB338</b>			<b>FOL126 (x8) [6]</b>
100x17 01/89→					

[6] Mechanical [6] Mécanique [6] Meccanico [6] Mecánico

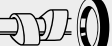
				
B x C x D	OE	MAT.		E x F x G
<b>V91629</b> 	605 40 326		45°	<b>VAG96261</b> 
39.80 x 8.00 x 92.00		MB		40.50 x 8.02 x 13.08
<b>V91621</b> 	13193.00.000.00		45° ss	
33.00 x 8.00 x 93.00		MG cr		

							
<b>BP990</b> Fibre Composite				<b>JA899</b>  (x4)		<b>HR363</b> 	<b>NA5064</b> 35.00x58.00x10.00mm ACM



BP990

# FIAT GROUP







**564**

 **87.00**







**Petrol**

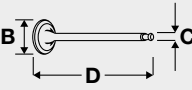
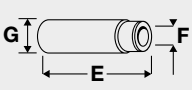

AR 30558      4 Cyl.      1712cc      77kW (105)PS      TD93      **1217**

					
<b>TB338</b> 100x17 01/89→	<b>TBK287</b> 01/89→ Component No: TB338; AE1006TP;AE1007TP		<b>KIT</b>		

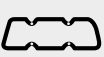
	
B x C x D	E x F x G
<b>V91629</b> ■ 39.80 x 8.00 x 92.00	<b>VAG96261</b> ■ ■ 40.50 x 8.02 x 13.08
<b>V91621</b> ■ 33.00 x 8.00 x 93.00	

							
<b>BP990</b> Fibre Composite (x2)				<b>JD221</b> (x2) <b>JA899</b> ■ (x4) ⊙ <b>JE744</b>		<b>HR363</b> ■	<b>NA5064</b> 35.00x58.00x10.00mm ACM



BP990

**565**







 **87.00**

**Petrol**







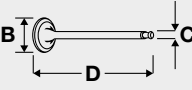
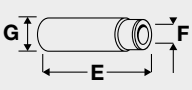

AR 30736      4 Cyl.      1712cc      79kW (107)PS      TD109      **1217**

AR 30737      4 Cyl.      1712cc      77-79kW (105-107)PS      TD110      **1217**

					
<b>TB338</b> 100x17	<b>TBK287</b> Component No: TB338; AE1006TP;AE1007TP		<b>KIT</b>		<b>FOL130</b> (x8)

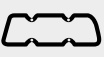







	
B x C x D	E x F x G
<b>V91629</b> ■ 39.80 x 8.00 x 92.00	<b>VAG96261</b> ■ ■ 40.50 x 8.02 x 13.08
<b>V91630</b> ■ 33.10 x 8.00 x 92.10	









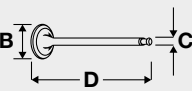
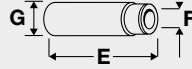

							
<b>BP990</b> Fibre Composite (x2)				<b>JD221</b> (x2) <b>JA899</b> ■ (x4) ⊙ <b>JE744</b>		<b>HR363</b> ■	<b>NA5064</b> 35.00x58.00x10.00mm ACM

















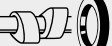





BP990



<b>566</b>	 <b>87.00</b>	<b>Petrol</b>	
<b>AR 30737 A</b>	4 Cyl.	1712cc	<b>77-79kW (105-107)PS</b>
	 <b>KIT</b>		 <b>KIT</b>
<b>TB338</b> 100x17	<b>TBK287</b> Component No: TB338; AE1006TP;AE1007TP		
			
			<b>FOL130 (x8)</b>

	
B x C x D	E x F x G
<b>V91629</b> 	<b>VAG96261</b> 
39.80 x 8.00 x 92.00	40.50 x 8.02 x 13.08
<b>V91630</b> 	
33.10 x 8.00 x 92.10	
OE	
MAT.	
	
	
	
605 40 326	45°
605 40 325	45°
MD cr	H

							
<b>BP990</b> Fibre Composite				 <b>JE744</b>			
							
<b>BP990</b>							

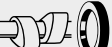
<b>567</b>	 <b>87.00</b>	<b>Petrol</b>	
<b>AR 30740</b>	4 Cyl.	1712cc	<b>77kW (105)PS</b>
			
<b>BP990</b> Fibre Composite			 <b>JA899</b>  (x4)
			
<b>BP990</b>			
			 <b>NA5064</b> 35.00x58.00x10.00mm ACM

# FIAT GROUP

**568**

**87.00**

**Petrol**



AR 30746	4 Cyl.	1712cc	101kW (137)PS	TD114	<b>1221</b>
AR 30747	4 Cyl.	1712cc	95-97kW (129-132)PS	TD115	<b>1221</b>

<b>TB274</b>					
121x20					
07/90→					

	OE	MAT.			
B x C x D				H	E x F x G
<b>V91622</b> ■	605 25 336		45°		<b>VAG96188B</b> ■
32.00 x 7.00 x 99.10		MB			40.05 x 7.02 x 12.09
<b>V91623</b> ■	605 25 337		45°		<b>VAG96218</b> ■
26.00 x 7.00 x 101.20		MD cr			40.50 x 7.02 x 12.09

AA5550 Fibre Composite (x2)	DT340	GT340		JD014 ■ (x4)	JN811 ■ (x5)	HR800 ■
BT340 Graphite Composite (x2)				JD565 ■ (x4)	JN810 ■ (x5)	
AA5550	BT340					

**569**

**87.00**

**Petrol**



AR 33401	4 Cyl.	1712cc	95kW (129)PS	TD122	<b>1221</b>
----------	--------	--------	--------------	-------	-------------

<b>TB274</b>					
121x20					

	OE	MAT.			
B x C x D				H	E x F x G
<b>V91622</b> ■	605 25 336		45°		<b>VAG96188B</b> ■
32.00 x 7.00 x 99.10		MB			40.05 x 7.02 x 12.09
<b>V91623</b> ■	605 25 337		45°		<b>VAG96218</b> ■
26.00 x 7.00 x 101.20		MD cr			40.50 x 7.02 x 12.09

AA5550 Fibre Composite (x2)	DT340	GT340		JD014 ■ (x4)	JN811 ■ (x5)	HR800 ■
BT340 Graphite Composite (x2)				JD565 ■ (x4)	JN810 ■ (x5)	
AA5550	BT340					

<b>570</b>	<b>87.00</b>	<b>Petrol</b>				
ES9 J4S	6 Cyl.	10.9:1	2946cc	150kW (204)PS	TD17397	<b>1222</b>
<b>TB727</b> 259x32 →07/06					<b>FOL164</b> (x24)	

B x C x D	OE	MAT.				E x F x G
<b>V94198</b> ■ 34.95 x 5.98 x 108.45	0948.A5		45°		H	<b>VAG96271B</b> ■ ■ ■ ■ ■ 40.00 x 6.00 x 11.06
<b>V94199</b> ■ 30.55 x 5.98 x 106.95	0949.A5		45°	ss		

			<b>HBS272</b> ☉ M10x1.50x147.00mm (x16)		<b>HR5062</b> ■	<b>NA5260</b> 38.00x50.00x6.00mm FPM

<b>571</b>	<b>87.00</b>	<b>Petrol</b>				
XFW	6 Cyl.	10.9:1	2946cc	150-152kW (204-207)PS	TD18825	<b>1222</b>
<b>AH5060</b> MLS, 0.740mm ■ <b>AH5050</b> MLS, 0.950mm ■ <b>AH5040</b> MLS, 0.740mm ■ <b>AH5070</b> MLS, 0.950mm ■	<b>CH5040</b> ■ <b>CH5060</b> ■			<b>JD5906</b> ■ <b>JD5907</b> ■ (x2)		<b>NA5260</b> 38.00x50.00x6.00mm FPM

<b>572</b>	<b>87.00</b>	<b>Petrol</b>				
XFW	6 Cyl.	10.9:1	2946cc	150-152kW (204-207)PS	TD18310	<b>1223</b>
<b>AH5060</b> MLS, 0.740mm ■ <b>AH5050</b> MLS, 0.950mm ■ <b>AH5040</b> MLS, 0.740mm ■ <b>AH5070</b> MLS, 0.950mm ■	<b>CH5040</b> ■ <b>CH5060</b> ■		<b>HBS272</b> ☉ M10x1.50x147.00mm (x16)	<b>JD5906</b> ■ <b>JD5907</b> ■ (x2)	<b>HR5062</b> ■	<b>NA5260</b> 38.00x50.00x6.00mm FPM

<b>573</b>	<b>87.30</b>	<b>Petrol</b>				
939 A.000	6 Cyl.	10.9:1	3196cc	191kW (260)PS	TD18914	<b>1223</b>
<b>TB727</b> 259x32 →07/06						
B x C x D	OE	MAT.				E x F x G
<b>V98001</b> ■ 35.00 x 6.00 x 101.40	71741112		45°			
<b>V98002</b> ■ 30.60 x 6.00 x 97.20	71741113		45°			

# FIAT GROUP

**574**



88.00

Petrol



170 B

4 Cyl.

1971cc

55kW (75)PS

TD4417

1224

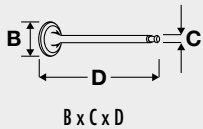

OE



H

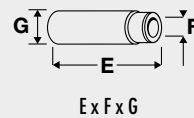

**V91972** ■  
42.60 x 8.00 x 108.80

96 059 361

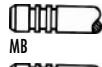

45°

H

**VAG96047** ■  
43.50 x 8.02 x 13.09



**V91970** ■  
34.50 x 8.00 x 108.40

96 147 032

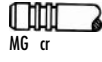

45°

ss

H

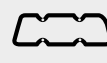

BM530 Fibre Composite, 1.400mm

DM533 ▲

HBS038 Ⓢ  
M11x1.50x175.00mm (x10)

JB851

JN244



BM530

**575**



88.00

Petrol



170 D

4 Cyl.

1971cc

62kW (84)PS

TD5102

1224

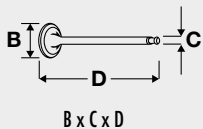

OE



H

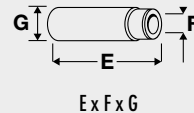

**V91972** ■  
42.60 x 8.00 x 108.80

96 059 361

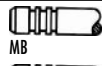

45°

H

**VAG96047** ■  
43.50 x 8.02 x 13.09



**V91970** ■  
34.50 x 8.00 x 108.40

96 147 032

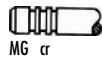

45°

ss

H

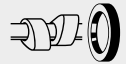
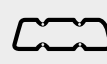

BM530 Fibre Composite, 1.400mm

DM533 ▲

HBS038 Ⓢ  
M11x1.50x175.00mm (x10)

JB841 ■

JN244



BM530

<b>576</b>	<b>88.00</b>	<b>Petrol</b>				
<b>XN 1T</b>	4 Cyl.	8:1	1971cc	<b>58-60kW (79-82)PS</b>	<b>TD4418</b>	<b>1225</b>
	<b>B x C x D</b>	<b>OE</b>	<b>MAT.</b>			
<b>V34459</b>	0948.33		<b>30°</b>	<b>H</b>	<b>VAG51007</b>	
42.50 x 8.00 x 118.30		<b>MB</b>			55.00 x 8.00 x 14.06	
<b>V34460</b>	0949.21		<b>45°</b>			
35.50 x 8.00 x 112.00		<b>MD</b>				

<b>BM530</b> Fibre Composite, 1.400mm	<b>DM533</b> ▲ <b>DM530</b> 01/84→	<b>GM533</b> ○	<b>HBS038</b> ⊕ M11x1.50x175.00mm (x10) 04/89→	<b>JB841</b> <b>JE647</b>	<b>JN244</b>	<b>HR569</b>	

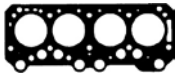

BM530

<b>577</b>	<b>88.00</b>	<b>Diesel</b>				
<b>8144.65</b>	4 Cyl.	22.1:1	1995cc	<b>44kW (60)PS</b>	<b>TD1055</b>	<b>1226</b>
	<b>B x C x D</b>	<b>OE</b>	<b>MAT.</b>			
<b>TB146</b>	149x30					
Length: 1419.2mm						
Groove Distance: 9.525						

	<b>B x C x D</b>	<b>OE</b>	<b>MAT.</b>			
<b>V90402</b>	4 733 348		<b>30°</b>	<b>H</b>	<b>VAG92193</b>	
41.00 x 8.00 x 122.00		<b>MG</b>			56.00 x 8.04 x 13.05	
<b>V90404</b>	4 733 349		<b>45°</b>	<b>H</b>	<b>VAG92194</b>	
33.00 x 8.00 x 122.00		<b>MG</b>			60.00 x 8.04 x 13.05	

<b>578</b>	<b>88.00</b>	<b>Diesel</b>					
<b>VM 4 HT</b>	4 Cyl.	22:1	1995cc	<b>61kW (83)PS</b>	<b>Turbocharged</b>	<b>TD150</b>	<b>1227</b>
<b>AY400</b> MLS, 1.420mm, 0 Notches	<b>DK570</b> ▲○	<b>GK570</b> ▲ [2]	<b>HBS105</b> ⊕ M14x2.00x137.00mm (x4)	<b>JC928</b>			
<b>BK570</b> Fibre Composite, 1.420mm, 0 Notches (x4)				<b>JD5144</b>			
<b>AY410</b> MLS, 1.520mm, 2 Notches				<b>JD025</b> (x4)			
<b>BP260</b> Fibre Composite, 1.520mm, 2 Notches				<b>JF123</b>			
<b>AY420</b> MLS, 1.620mm, 1 Notch							
<b>BK580</b> Fibre Composite, 1.620mm, 1 Notch (x4)							



AY400, AY410, AY420  
[2] With cylinder sleeve ring

BK570, BP260, BK580

[2] avec deux bagues de chemises de cylindre

[2] con anello tenuta canna cilindro

[2] Con segmentos para camisa

# FIAT GROUP

**579**



**88.00**

**Diesel**



<b>VM 80 A</b>	4 Cyl.	22:1	1995cc	<b>70kW (95)PS</b>	<b>Turbocharged</b>	<b>TD151</b>	<b>1228</b>
<b>VM4HT/2</b>	4 Cyl.		1995cc	<b>60kW (82)PS</b>	<b>Turbocharged</b>	<b>TD160</b>	<b>1228</b>

 $B \times C \times D$				 $E \times F \times G$			
OE	MAT.						
<b>V91437</b> ■	605 07 189		35°			<b>VAG96187</b> ■ ■ ■	
40.00 x 8.00 x 121.00		MD cr				55.00 x 8.02 x 14.06	
<b>V91438</b> ■	605 07 190		45°				
34.00 x 8.00 x 121.00		MD cr					

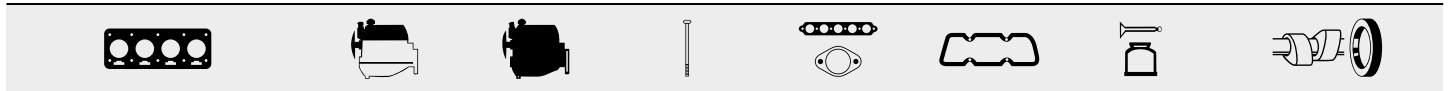

<b>AY400</b> MLS, 1.420mm, 0 Notches <b>BK570</b> Fibre Composite, 1.420mm, 0 Notches (x4) <b>AY410</b> MLS, 1.520mm, 2 Notches <b>BP260</b> Fibre Composite, 1.520mm, 2 Notches <b>AY420</b> MLS, 1.620mm, 1 Notch <b>BK580</b> Fibre Composite, 1.620mm, 1 Notch (x4)	<b>DK570</b> ▲○	<b>GK570</b> ▲ [2]	<b>HBS105</b> ☉ M14x2.00x137.00mm (x4)	<b>JC928</b> ■ <b>JD5144</b> <b>JD025</b> ■ (x4) <b>JF123</b>			
--	-----------------	--------------------	---	--	--	--	--

<b>AY400, AY410, AY420</b>	<b>BK570, BP260, BK580</b>						
[2] With cylinder sleeve ring	[2] avec deux bagues de chemises de cylindre	[2] con anello tenuta canna cilindro	[2] Con segmentos para camisa				

**580**



**88.00**

**Diesel**



<b>F1AE0481C</b>	4 Cyl.	18.5:1	2286cc	<b>81kW (110)PS</b>	<b>Turbo Intercooled</b>	<b>TD16407</b>	<b>1229</b>
------------------	--------	--------	--------	---------------------	--------------------------	----------------	-------------

<b>TB723</b>			<b>KIT</b>				
178x30 →07/06							

 $B \times C \times D$				 $E \times F \times G$			
OE	MAT.						
<b>V94592</b> ■	504 069 199		45°	H			
30.00 x 6.00 x 120.40		MB cr					
<b>V98018</b> ■	504 069 199		45°				
30.00 x 6.00 x 120.40		MB cr					
<b>V94593</b> ■	504 378 070		45°	H			
30.00 x 6.00 x 120.35		MG cr					
<b>V98019</b> ■	500 362 856		45°				
30.00 x 6.00 x 120.35		MG cr					

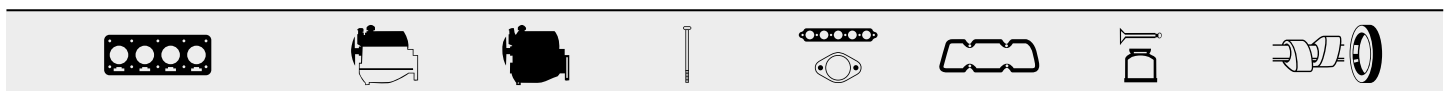

<b>AB5720</b> MLS, 1.100mm <b>AB5730</b> MLS, 1.200mm <b>AB5740</b> MLS, 1.300mm	<b>CB5720</b> ▲ 08/04→	<b>FB5721</b> ▲ →08/04 <b>FB5722</b> ▲ 08/04→	<b>HBS251</b> ☉ M14x1.50x193.00mm (x6)	<b>JD5338</b> ■ <b>JD5337</b> ■	<b>JM5201</b> (Steel Elastomer) →08/04 <b>JM5202</b> (Elastomer) 08/04→	<b>NA5201</b> 34.00x60.00x10.00mm FPM	
--	---------------------------	--	---	------------------------------------	--	--	--

<b>AB5720, AB5730, AB5740</b>							

<b>581</b>	<b>88.00</b>	<b>Diesel</b>					
<b>F1AE0481T</b>	4 Cyl.	19:1	2286cc	<b>93kW (126)PS</b>	<b>Turbo Intercooled</b>	<b>TD24632</b>	<b>1230</b>

AB5720 MLS, 1.100mm	CB5720 ▲	FB5722 ▲	HBS251 ☉ M14x1.50x193.00mm (x6)	JD5338 ■ JD5337 ■			
AB5730 MLS, 1.200mm							
AB5740 MLS, 1.300mm							



AB5720, AB5730, AB5740

<b>582</b>	<b>88.00</b>	<b>Diesel</b>					
<b>F1AE0481A Euro 3 (D3)</b>	4 Cyl.		2287cc	<b>70kW (95)PS</b>		<b>TD17144</b>	<b>1229</b>

<b>TB723</b>							
178x30							

B x C x D	OE	MAT.	45°		E x F x G
<b>V94592 ■</b> 30.00 x 6.00 x 120.40	504 069 199	MB cr	45°	H	
<b>V98018 ■</b> 30.00 x 6.00 x 120.40	504 069 199	MB cr	45°		
<b>V94593 ■</b> 30.00 x 6.00 x 120.35	504 378 070	MG cr	45°	H	
<b>V98019 ■</b> 30.00 x 6.00 x 120.35	500 362 856	MG cr	45°		

AB5720 MLS, 1.100mm	CB5720 ▲	FB5721 ▲	HBS251 ☉ M14x1.50x193.00mm (x6)	JD5338 ■ JD5337 ■	JM5201 (Steel Elastomer) JM5202 (Elastomer)		NA5201 34.00x60.00x10.00mm FPM
AB5730 MLS, 1.200mm							
AB5740 MLS, 1.300mm							



AB5720, AB5730, AB5740

# FIAT GROUP

**583**



88.00

**Diesel**



F1AE0481B Euro 3 (D3)

4 Cyl.

2287cc

85kW (116)PS

TD17145

1229

B x C x D	OE	MAT.		
<b>V94592</b> ■	504 069 199		45°	H
30.00 x 6.00 x 120.40				
<b>V98018</b> ■	504 069 199		45°	
30.00 x 6.00 x 120.40				
<b>V94593</b> ■	504 378 070		45°	H
30.00 x 6.00 x 120.35				
<b>V98019</b> ■	500 362 856		45°	
30.00 x 6.00 x 120.35				

AB5720 MLS, 1.100mm	CB5720 ▲	FB5721 ▲	HBS251 ⊕	JD5338 ■	JM5201		NA5201
AB5730 MLS, 1.200mm			M14x1.50x193.00mm (x6)	JD5337 ■	(Steel Elastomer)		34.00x60.00x10.00mm FPM
AB5740 MLS, 1.300mm					JM5202		
					(Elastomer)		



AB5720, AB5730, AB5740

**584**



88.00

**Diesel**



F1AE 0481 C

4 Cyl.

2287cc

81kW (110)PS

Turbo Intercooled

FM9055

1231

B x C x D	OE	MAT.		
<b>V94592</b> ■	504 069 199		45°	H
30.00 x 6.00 x 120.40				
<b>V98018</b> ■	504 069 199		45°	
30.00 x 6.00 x 120.40				
<b>V94593</b> ■	504 378 070		45°	H
30.00 x 6.00 x 120.35				
<b>V98019</b> ■	500 362 856		45°	
30.00 x 6.00 x 120.35				

**585**



88.00

**Diesel**



F1AE0481D Euro 4 (D4)

4 Cyl.

19:1

2287cc

88kW (120)PS

Turbo Intercooled

TD20264

1232



TB723						
178x30						







AB5720 MLS, 1.100mm	CB5720 ▲	FB5722 ▲	HBS251 ⊕	JD5338 ■	JM5202	NA5201
AB5730 MLS, 1.200mm			M14x1.50x193.00mm (x6)	JD5337 ■	(Elastomer)	34.00x60.00x10.00mm FPM
AB5740 MLS, 1.300mm						













AB5720, AB5730, AB5740



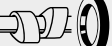

<b>586</b>	 <b>88.00</b>	<b>Diesel</b>				
<b>F1AE0481FA Euro 4 (D4)</b>	4 Cyl.	2287cc	<b>70-78kW (95-106)PS</b>	<b>Turbo Intercooled</b>	<b>TD19231</b>	<b>1232</b>
<b>F1AE0481GA Euro 4 (D4)</b>	4 Cyl.	2287cc	<b>85-93kW (116-126)PS</b>	<b>Turbo Intercooled</b>	<b>TD19232</b>	<b>1232</b>
<b>F1AE0481HA Euro 4 (D4)</b>	4 Cyl.	2287cc	<b>100kW (136)PS</b>	<b>Turbo Intercooled</b>	<b>TD19233</b>	<b>1232</b>







					
<b>TB723</b>					
178x30					

							
<b>AB5720</b> MLS, 1.100mm			<b>HBS251</b> 	<b>JD5338</b> 	<b>JM5201</b> (Steel Elastomer)		<b>NA5201</b> 34.00x60.00x10.00mm FPM
<b>AB5730</b> MLS, 1.200mm			M14x1.50x193.00mm (x6)	<b>JD5337</b> 	<b>JM5202</b> (Elastomer)		
<b>AB5740</b> MLS, 1.300mm							



AB5720, AB5730, AB5740

<b>587</b>	 <b>88.00</b>	<b>Diesel</b>				
<b>F1AE0481F Euro 4 (D4)</b>	4 Cyl.	2287cc	<b>70kW (95)PS</b>	<b>Turbo Intercooled</b>	<b>TD28231</b>	<b>1230</b>
<b>F1AE0481G Euro 4 (D4)</b>	4 Cyl.	2287cc	<b>85kW (116)PS</b>	<b>Turbo Intercooled</b>	<b>TD28232</b>	<b>1230</b>
<b>F1AE0481H Euro 4 (D4)</b>	4 Cyl.	2287cc	<b>85kW (116)PS</b>	<b>Turbo Intercooled</b>	<b>TD28233</b>	<b>1230</b>
<b>F1AE0481U Euro 4 (D4)</b>	4 Cyl.	2287cc	<b>78kW (106)PS</b>	<b>Turbo Intercooled</b>	<b>TD26638</b>	<b>1234</b>
<b>F1AE0481V Euro 4 (D4)</b>	4 Cyl.	2287cc	<b>93kW (126)PS</b>	<b>Turbo Intercooled</b>	<b>TD26637</b>	<b>1234</b>
<b>F1AE3481A Euro 5</b>	4 Cyl.	2287cc	<b>78kW (106)PS</b>	<b>Turbo Intercooled</b>	<b>TD26934</b>	<b>1234</b>
<b>F1AE3481B Euro 5</b>	4 Cyl.	2287cc	<b>93kW (126)PS</b>	<b>Turbo Intercooled</b>	<b>TD26935</b>	<b>1234</b>
<b>F1AE3481C Euro 5</b>	4 Cyl.	2287cc	<b>107kW (146)PS</b>	<b>Turbo Intercooled</b>	<b>TD26943</b>	<b>1234</b>

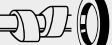
							
	<b>CB5720</b> ▲						

# FIAT GROUP

**588**



88.00

**Diesel**



F1AE0481M

4 Cyl.

2287cc

100kW (136)PS

Turbo Intercooled

TD19156

**1232**

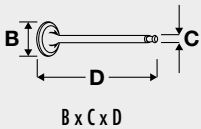

OE

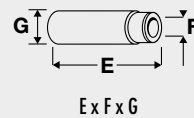

Part No.	OE	MAT.	Angle	Head
<b>V94592</b>	504 069 199		45°	H
30.00 x 6.00 x 120.40				
<b>V98018</b>	504 069 199		45°	
30.00 x 6.00 x 120.40				
<b>V94593</b>	504 378 070		45°	H
30.00 x 6.00 x 120.35				
<b>V98019</b>	500 362 856		45°	
30.00 x 6.00 x 120.35				

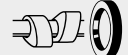
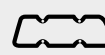

AB5720 MLS, 1.100mm  
AB5730 MLS, 1.200mm  
AB5740 MLS, 1.300mm

CB5720 ▲

HBS251   
M14x1.50x193.00mm (x6)

JD5338   
JD5337

JM5201  
(Steel Elastomer)  
JM5202  
(Elastomer)

NA5201  
34.00x60.00x10.00mm FPM



AB5720, AB5730, AB5740

**589**



88.00

**Diesel**



F1AE0481N

4 Cyl.

19:1

2287cc

96kW (131)PS

Turbo Intercooled

TD24778

**1233**

F1AE3481E

4 Cyl.

16.2:1

2287cc

109kW (148)PS

Turbo Intercooled

TD25175

**1235**

F1AE3481G

4 Cyl.

16.2:1

2287cc

83kW (113)PS

Turbo Intercooled

TD26313

**1236**

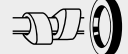
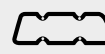

AB5720 MLS, 1.100mm  
AB5730 MLS, 1.200mm  
AB5740 MLS, 1.300mm

CB5720 ▲

FB5722 ▲

HBS251   
M14x1.50x193.00mm (x6)

JD5338   
JD5337

JM5202  
(Elastomer)

NA5201  
34.00x60.00x10.00mm FPM



AB5720, AB5730, AB5740

**590**



88.00

**Diesel**



F1AE0481R Euro 4 (D4)

4 Cyl.

2287cc

85kW (116)PS

Turbo Intercooled

TD28234

**1230**

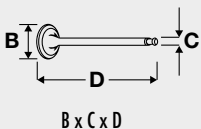



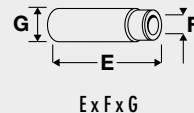



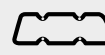



OE





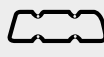

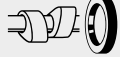

















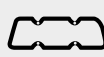

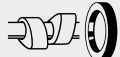









<b>V94593</b>	504 378 070		45°	H
30.00 x 6.00 x 120.35				







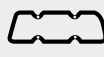

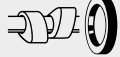









CB5720 ▲

<b>591</b>	 <b>88.00</b>	<b>Diesel</b>					
<b>FIAE3481D</b>	4 Cyl.	16.2:1	2287cc	<b>96kW (131)PS</b>	<b>Turbo Intercooled</b>	<b>TD25174</b>	<b>1235</b>
							
AB5720 MLS, 1.100mm AB5730 MLS, 1.200mm AB5740 MLS, 1.300mm	CB5720 ▲	FB5722 ▲ 08/05→	HBS251 ☉ M14x1.50x193.00mm (x6)	JD5338 ■ JD5337 ■	JM5202 (Elastomer)		NA5201 34.00x60.00x10.00mm FPM
	AB5720, AB5730, AB5740						

<b>592</b>	 <b>88.00</b>	<b>Petrol</b>					
<b>834 G.000</b>	6 Cyl.		2492cc	<b>119kW (162)PS</b>		<b>TD1066</b>	<b>1237</b>
							
TB383 134x25.4			KIT				
							
				JD222 ■ JD223 ■ (x6)	JN808 ☒ JN807 ☒		

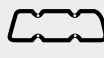
<b>593</b>	 <b>88.00</b>	<b>Petrol</b>					
<b>AR 01646</b>	6 Cyl.	9:1	2492cc	<b>110-116kW (150-158)PS</b>		<b>TD36</b>	<b>1238</b>
							
TB134 134x25.4 05/85→			KIT				
							
				JD224 ■			NA5163 32.00x47.00x10.00mm FPM

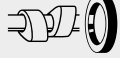
<b>594</b>	 <b>88.00</b>	<b>Petrol</b>					
<b>AR 01648</b>	6 Cyl.		2492cc	<b>113kW (154)PS</b>		<b>TD10150</b>	<b>1239</b>
							
TB134 134x25.4			KIT				
							
				JD223 ■ (x6)	JN808 ☒ JN807 ☒		NA5163 32.00x47.00x10.00mm FPM

# FIAT GROUP

<b>595</b>	88.00	<b>Petrol</b>				
AR 01911	6 Cyl.	9:1	2492cc	110-115kW (150-156)PS	TD42	1238
<b>TB134</b> 134x25.4						
				JD224		NA5163 32.00x47.00x10.00mm FPM

<b>596</b>	88.00	<b>Petrol</b>				
AR 01928	6 Cyl.		2492cc	110-117kW (150-159)PS	TD44	1238
<b>TB532</b> 185x28						
						VAG96262 48.50 x 9.00 x 14.06

<b>597</b>	88.00	<b>Petrol</b>				
AR 32401	6 Cyl.	7.3:1	2492cc	140kW (190)PS	TD9464	1242
AR 34201	6 Cyl.	10.3:1	2492cc	140kW (190)PS	TD11601	1242

<b>TB532</b> 185x28						
						VAG96184 43.00 x 7.04 x 12.08
<b>V94210</b> 33.60 x 7.00 x 102.00	605 82 738		45°	Y	H	
<b>V94211</b> 29.10 x 7.00 x 102.20	605 82 739		45°	ss	H	

<b>AY631</b> Fibre Composite <b>AY620</b> Fibre Composite	CY620			JD586  (x2) JD587  (x6)	JP071 JP070	NA5163 32.00x47.00x10.00mm FPM
AY620	AY631					

<b>598</b>	<b>88.00</b>	<b>Petrol</b>	
AR 32405	6 Cyl.	2492cc	141kW (192)PS
<b>TB532</b> 185x28 →05/04			

B x C x D	E x F x G
<b>V94210</b> 33.60 x 7.00 x 102.00	<b>VAG96184</b> 43.00 x 7.04 x 12.08
<b>V94211</b> 29.10 x 7.00 x 102.20	









<b>BT381</b> Fibre Composite, 1650mm	<b>CY620</b>	<b>FY620</b>	<b>JD586</b>	<b>JP071</b>			<b>NA5163</b> 32.00x47.00x10.00mm FPM
<b>AY641</b> Fibre Composite, 1650mm			<b>JD587</b>	<b>JP070</b>			
<b>AY641</b>	<b>BT381</b>						







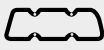

<b>599</b>	<b>88.00</b>	<b>Petrol</b>	
AR 36201	6 Cyl.	2492cc	138kW (188)PS
<b>TB532</b> 185x28 →09/07			











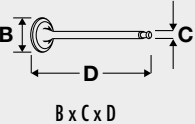

B x C x D	E x F x G
<b>V94210</b> 33.60 x 7.00 x 102.00	<b>VAG96184</b> 43.00 x 7.04 x 12.08
<b>V94211</b> 29.10 x 7.00 x 102.20	

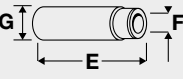
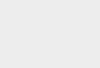





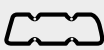

<b>BT381</b> Fibre Composite, 1650mm	<b>CY620</b>	<b>FY620</b>	<b>JD586</b> (x2)	<b>JP071</b>			<b>NA5163</b> 32.00x47.00x10.00mm FPM
<b>AY641</b> Fibre Composite, 1650mm			<b>JD587</b> (x6)	<b>JP070</b>			
<b>AY641</b>	<b>BT381</b>						











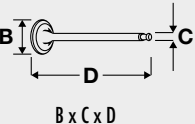

# FIAT GROUP

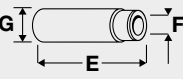
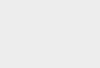





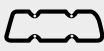





<b>600</b>	 88.00	<b>Petrol</b>	
AR 66201	6 Cyl.	2492cc	120kW (163)PS
			TD132 <b>1241</b>
			
			
			<b>NA5163</b> 32.00x47.00x10.00mm FPM













<b>601</b>	 88.00	<b>Petrol</b>	
AR 67301	6 Cyl.	2492cc	121kW (165)PS
			TD139 <b>1243</b>
			
			
<b>TB383</b> 134x25.4 →12/93			



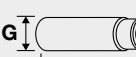









	OE						
B x C x D		MAT.				E x F x G	
						<b>VAG96262</b> ■ 48.50 x 9.00 x 14.06	
							
				JD222 ■ (x2) JD223 ■ (x6) JD224 ■	JN808 ■ JN807 ■	<b>NJ951</b> 32.00x50.00x8.00mm FPM <b>NA5163</b> 32.00x47.00x10.00mm FPM	

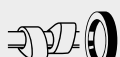

<b>602</b>	 88.00	<b>Petrol</b>	
AR 67302	6 Cyl.	2492cc	120kW (163)PS
			TD9468 <b>1243</b>
			
			
<b>TB383</b> 134x25.4			











	OE						
B x C x D		MAT.				E x F x G	
						<b>VAG96262</b> ■ 48.50 x 9.00 x 14.06	
							
				JD224 ■	<b>NJ951</b> 32.00x50.00x8.00mm FPM <b>NA5163</b> 32.00x47.00x10.00mm FPM		



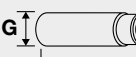







<b>603</b>	 <b>88.00</b>	<b>Petrol</b>	
<b>AR 67303</b>	6 Cyl.	2492cc	<b>120kW (163)PS</b>
			
			
<b>TB383</b> 134x25.4			
			
			<b>JD224</b> 
			<b>NJ951</b> 32.00x50.00x8.00mm FPM

<b>604</b>	 <b>88.00</b>	<b>Diesel</b>	
<b>VM-HR 588 HT</b>	5 Cyl.	22:1	<b>76-77kW (103-105)PS</b>
		2493cc	<b>Turbocharged</b>
			
			
<b>V91437</b> 	605 07 189		<b>VAG96187</b> 
40.00 x 8.00 x 121.00		35°	55.00 x 8.02 x 14.06
<b>V91438</b> 	605 07 190		
34.00 x 8.00 x 121.00		45°	

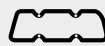
							
<b>BK570</b> Fibre Composite, 1.420mm, 0 Notches (x5)	<b>DK572</b> 	<b>GK571</b>  [1]	<b>HBS106</b> 	<b>JC928</b>  (x5)	<b>JN581</b>		
<b>BP260</b> Fibre Composite, 1.520mm, 2 Notches		[2]	M14x2.00x137.00mm (x5)	<b>JD5144</b>			
<b>BK580</b> Fibre Composite, 1.620mm, 1 Notch (x5)				<b>JD025</b>  (x5)			

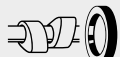
<b>605</b>	 <b>92.00</b>	<b>Diesel</b>	
<b>VM 82 A</b>	3 Cyl.	22:1	<b>54kW (73)PS</b>
<b>VM 96 A</b>	3 Cyl.	22:1	<b>62kW (84)PS</b>
		1779cc	<b>Turbocharged</b>

			
			
<b>V91437</b> 	605 07 189		<b>VAG96187</b> 
40.00 x 8.00 x 121.00		35°	55.00 x 8.02 x 14.06
<b>V91438</b> 	605 07 190		
34.00 x 8.00 x 121.00		45°	

							
<b>BK570</b> Fibre Composite, 1.420mm, 0 Notches (x3)	<b>DR040</b> 		<b>HBS107</b> 	<b>JC928</b>  (x3)			
<b>BP260</b> Fibre Composite, 1.520mm, 2 Notches			M14x2.00x137.00mm (x8)	<b>JD5144</b> (x3)			
<b>BK580</b> Fibre Composite, 1.620mm, 1 Notch (x3)				<b>JD025</b>  (x3)			

## 606

 92.00

### Diesel



VM4HT 2.4

4 Cyl.









2393cc

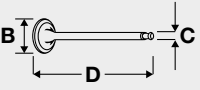

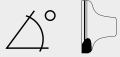

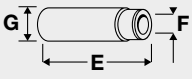





69-70kW (94-95)PS

Turbocharged

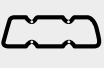
TD159

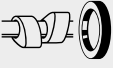
1246

					
B x C x D	OE	MAT.			E x F x G
<b>V91437</b> ■	605 07 189		35°		<b>VAG96187</b> ■ ■ ■
40.00 x 8.00 x 121.00		MD cr			55.00 x 8.02 x 14.06
<b>V91438</b> ■	605 07 190		45°		
34.00 x 8.00 x 121.00		MD cr			

							
<b>AN300</b> Fibre Composite <b>AY400</b> MLS, 1.420mm, 0 Notches <b>AY410</b> MLS, 1.520mm, 2 Notches <b>BP260</b> Fibre Composite, 1.520mm, 2 Notches <b>AY420</b> MLS, 1.620mm, 1 Notch	<b>CN306</b> <b>DC373</b> ▲ <b>DK570</b> ▲○	<b>GH857</b> ▲ [1] <b>GK570</b> ▲ [2]	<b>HBS105</b> △ M14x2.00x137.00mm (x4)	<b>JA840</b> ■ 01/76 → 12/82 <b>JC497</b> ■ 01/83 → 12/84 <b>JD5144</b> <b>JA829</b> ■ (x4)			
							
<b>AN300</b>	<b>AY400, AY410, AY420</b>	<b>BP260</b>					
[1] Without crankshaft seal [2] With cylinder sleeve ring		[1] sans bague d'étanchéité - vilebrequin [2] avec deux bagues de chemises de cylindre		[1] senza paraolio-albero a gomiti [2] con anello tenuta canna cilindro		[1] sin cigüeñal retén [2] Con segmentos para camisa	

## 607

 92.00

### Diesel



VM 81 A

4 Cyl.

22:1









2393cc

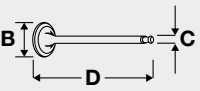

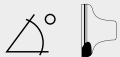

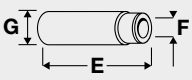



81kW (110)PS

Turbocharged



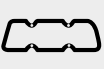





TD152



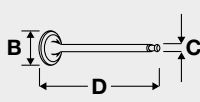

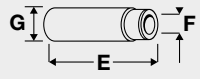

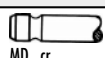
1245

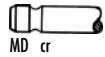
					
B x C x D	OE	MAT.			E x F x G
<b>V91437</b> ■	605 07 189		35°		<b>VAG96187</b> ■ ■ ■
40.00 x 8.00 x 121.00		MD cr			55.00 x 8.02 x 14.06
<b>V91438</b> ■	605 07 190		45°		
34.00 x 8.00 x 121.00		MD cr			



							
<b>AY400</b> MLS, 1.420mm, 0 Notches <b>BK570</b> Fibre Composite, 1.420mm, 0 Notches (x4) <b>AY410</b> MLS, 1.520mm, 2 Notches <b>BP260</b> Fibre Composite, 1.520mm, 2 Notches <b>AY420</b> MLS, 1.620mm, 1 Notch <b>BK580</b> Fibre Composite, 1.620mm, 1 Notch (x4)	<b>DK570</b> ▲○	<b>GK570</b> ▲ [2]	<b>HBS105</b> △ M14x2.00x137.00mm (x4)	<b>JC928</b> ■ <b>JD5144</b> <b>JD025</b> ■ (x4) ○ JF123			
							
<b>AY400, AY410, AY420</b>	<b>BK570, BP260, BK580</b>						
[2] With cylinder sleeve ring		[2] avec deux bagues de chemises de cylindre		[2] con anello tenuta canna cilindro		[2] Con segmentos para camisa	

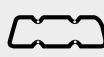



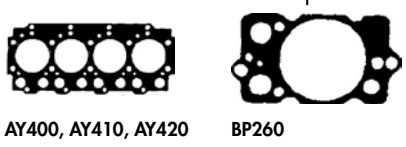





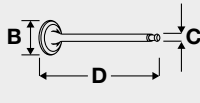

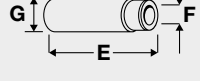

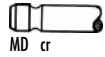

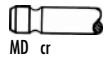
<b>608</b>  <b>92.00</b>		<b>Diesel</b>				
<b>VM 07 B</b>	4 Cyl.	22:1	2499cc	<b>92kW (125)PS</b>	<b>Turbocharged</b>	<b>TD149 1248</b>
 B x C x D	OE	MAT.	 35°	 45°	 E x F x G	
<b>V91437</b>  40.00 x 8.00 x 121.00	605 07 189	 MD cr			<b>VAG96187</b>  55.00 x 8.02 x 14.06	
<b>V91438</b>  34.00 x 8.00 x 121.00	605 07 190	 MD cr				

							
<b>AY400</b> MLS, 1.420mm, 0 Notches <b>AY410</b> MLS, 1.520mm, 2 Notches <b>BP260</b> Fibre Composite, 1.520mm, 2 Notches <b>AY420</b> MLS, 1.620mm, 1 Notch	<b>DK570</b> ▲○	<b>GK573</b> ▲	<b>HBS105</b> ⊕ M14x2.00x137.00mm (x4) →12/92 <b>HBS108</b> ⊕ M14x2.00x137.00mm (x4) 01/93→	<b>JD5144</b>	<b>JP068</b>		

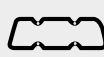

<b>609</b>  <b>92.00</b>		<b>Diesel</b>				
<b>VM 08 B</b>	4 Cyl.	22:1	2499cc	<b>92kW (125)PS</b>	<b>Turbocharged</b>	<b>TD9771 1248</b>
<b>VM 31 B</b>	4 Cyl.	22:1	2499cc	<b>92-125kW (125-170)PS</b>	<b>Turbocharged</b>	<b>TD9768 1248</b>

 B x C x D	OE	MAT.	 35°	 45°	 E x F x G	
<b>V91437</b>  40.00 x 8.00 x 121.00	605 07 189	 MD cr			<b>VAG96187</b>  55.00 x 8.02 x 14.06	
<b>V91438</b>  34.00 x 8.00 x 121.00	605 07 190	 MD cr				

							
<b>AY400</b> MLS, 1.420mm, 0 Notches <b>AY410</b> MLS, 1.520mm, 2 Notches <b>AY420</b> MLS, 1.620mm, 1 Notch	<b>DK570</b> ▲○	<b>GK573</b> ▲	<b>HBS105</b> ⊕ M14x2.00x137.00mm (x4)	<b>JD5144</b>	<b>JP068</b>		

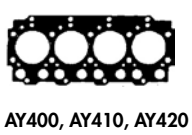

# FIAT GROUP

## 610

92.00

**Diesel**



VM 32 B      4 Cyl.      22:1      2499cc      **92kW (125)PS**      **Turbocharged**      TD127      **1248**

B x C x D	OE	MAT.		E x F x G
<b>V91437</b>	605 07 189		35°	<b>VAG96187</b>
40.00 x 8.00 x 121.00		MD cr		55.00 x 8.02 x 14.06
<b>V91438</b>	605 07 190		45°	
34.00 x 8.00 x 121.00		MD cr		

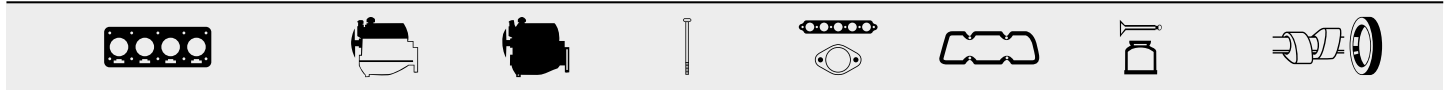

**BP260** Fibre Composite, 1.520mm, 2 Notches      **DK570**      **GK573**      **HBS105**      **JD5144**      **JP068**

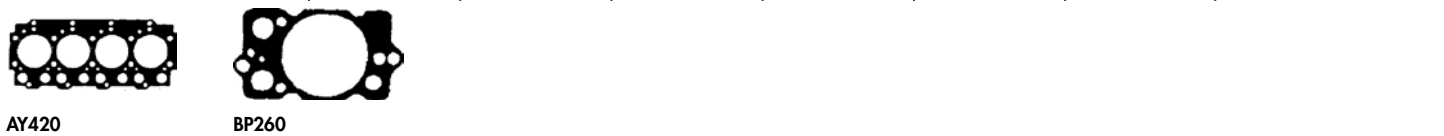

## 611

92.00

**Diesel**



VM 84 A      4 Cyl.      22:1      2499cc      **84kW (114)PS**      **Turbocharged**      TD154      **1248**

B x C x D	OE	MAT.		E x F x G
<b>V91437</b>	605 07 189		35°	<b>VAG96187</b>
40.00 x 8.00 x 121.00		MD cr		55.00 x 8.02 x 14.06
<b>V91438</b>	605 07 190		45°	
34.00 x 8.00 x 121.00		MD cr		

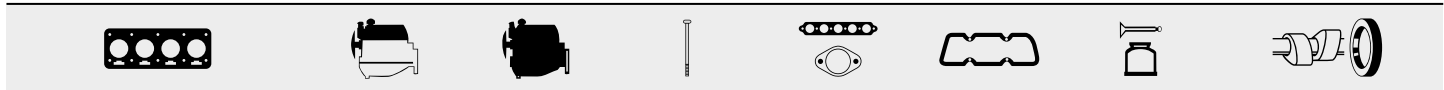

**AY400** MLS, 1.420mm, 0 Notches      **DK570**      **GK572**      **HBS105**      **JC928** (x4)      **JD5144**

**BK570** Fibre Composite, 1.420mm, 0 Notches (x4)      →01/95



**AY410** MLS, 1.520mm, 2 Notches      →12/92







**BP260** Fibre Composite, 1.520mm, 2 Notches      **HBS108**











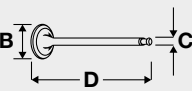

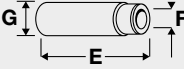

**AY420** MLS, 1.620mm, 1 Notch      M14x2.00x137.00mm (x4)







**BK580** Fibre Composite, 1.620mm, 1 Notch (x4)      01/93→



<b>612</b>	 <b>93.00</b>	<b>Diesel</b>				
8144.61	4 Cyl.	21:1	2428cc	53-55kW (72-75)PS	TD4408	1250

					
<b>TB135</b> 152x30 Polychloroprene (Neoprene)	<b>TBK045</b> Component No: TB135; AE1011TP;AE1010GP		<b>KIT</b>		

	OE	MAT.				
B x C x D						E x F x G
<b>V91292</b> ■ 40.80 x 8.00 x 120.70	7 301 820	 MB cr	30°	Y	H	 <b>VAG92193</b> ■ 56.00 x 8.04 x 13.05
<b>V91293</b> ■ 34.50 x 8.00 x 122.00	7 301 821	 MD	45°			 <b>VAG92373</b> ■ 56.00 x 8.03 x 13.04
<b>V91294</b> ■ 34.50 x 8.00 x 122.00	7 302 157	 MF cr	45°		H	 <b>VAG92444</b> ■ 56.00 x 8.00 x 13.04
						 <b>VAG92194</b> ■ 60.00 x 8.04 x 13.05
						 <b>VAG92369</b> ■ 60.00 x 8.00 x 13.07
						 <b>VAG92445</b> ■ 60.00 x 8.00 x 13.04

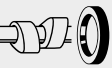
							
<b>BE580</b> Fibre Composite, 1.350mm	<b>DE588</b> ▲	<b>FY291</b> ▲ [1]	<b>HBS011</b> ① M12x1.25x119.00mm (x12)	<b>JC054</b> ■ (x4) <b>JC055</b> ■ (x4)	<b>JN462</b> →Eng.574798 <b>JN594</b> Eng.544799→	<b>HR602</b> ■	<b>NP068</b> 55.00x70.00x8.00mm FPM



**BE580**

[1] Without crankshaft seal

[1] sans bague d'étanchéité - vilebrequin

[1] senza paraolio-albero a gomiti

[1] sin cigüeñal retén

## 613

## 93.00

## Diesel



8140.07.2710	4 Cyl.	18:1	2499cc	55kW (75)PS		TD27358	1277
8140.07.2711	4 Cyl.	18:1	2499cc	55kW (75)PS		TD27359	1277
8140.07.3711 Euro 1	4 Cyl.	19:1	2499cc	53kW (72)PS		TD27365	1277
8140.07.3712 Euro 1	4 Cyl.	19:1	2499cc	53kW (72)PS		TD27366	1277
8140.07.3713 Euro 1	4 Cyl.	19:1	2499cc	53kW (72)PS		TD27367	1277
8140.21	4 Cyl.	18:1	2445cc		Turbocharged	FM9103	1251
8140.21.201	4 Cyl.	18:1	2445cc	68kW (92)PS	Turbocharged	TD27368	1254
8140.21.202	4 Cyl.	18:1	2445cc	68kW (92)PS	Turbocharged	TD27369	1254
8140.21.203	4 Cyl.	18:1	2445cc	68kW (92)PS	Turbocharged	TD27370	1254
8140.21.212	4 Cyl.	18:1	2445cc	68kW (92)PS	Turbocharged	TD27371	1254
8140.21.212, 8140.21.290	4 Cyl.		2445cc		Turbocharged	FM9241	
8140.21.290	4 Cyl.	18:1	2445cc	68kW (92)PS	Turbocharged	TD27372	1254
8140.27.210, 8140.27.213	4 Cyl.	18:1	2445cc	77kW (105)PS	Turbocharged	FM9131	1256
8140.27.218	4 Cyl.	18:1	2445cc	77kW (105)PS	Turbocharged	FM19131	1257
8140.275.2811, 8140.275.3811	4 Cyl.	18:1	2499cc		Turbocharged	FM9265	
8140.67 (290B7W), 8144.67	4 Cyl.	22:1	2500cc			FM9170	1315

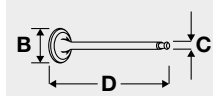

B x C x D

OE



MAT.



E x F x G

B x C x D	OE	MAT.	30°	45°	H	E x F x G
V91292 ■ 40.80 x 8.00 x 120.70	7 301 820	MB cr	30°	Y	H	VAG92193 ■ 56.00 x 8.04 x 13.05
V91293 ■ 34.50 x 8.00 x 122.00	7 301 821	MD	45°			VAG92373 ■ 56.00 x 8.03 x 13.04
V91294 ■ 34.50 x 8.00 x 122.00	7 302 157	MF cr	45°		H	VAG92444 ■ 56.00 x 8.00 x 13.04
						VAG92194 ■ 60.00 x 8.04 x 13.05
						VAG92369 ■ 60.00 x 8.00 x 13.07
						VAG92445 ■ 60.00 x 8.00 x 13.04

## 614

## 93.00

## Diesel



8140.21.200

4 Cyl.

18:1

2445cc

68kW (92)PS

Turbocharged

TD1703

1252

<b>TB250</b> 153x30 Eng. → 1307400					

B x C x D	OE	MAT.				E x F x G
<b>V91292</b> ■ 40.80 x 8.00 x 120.70	7 301 820	MB cr	30°	Y	H	VAG92193 ■ 56.00 x 8.04 x 13.05
<b>V91293</b> ■ 34.50 x 8.00 x 122.00	7 301 821	MD	45°			VAG92373 ■ 56.00 x 8.03 x 13.04
<b>V91294</b> ■ 34.50 x 8.00 x 122.00	7 302 157	MF cr	45°		H	VAG92444 ■ 56.00 x 8.00 x 13.04
						VAG92194 ■ 60.00 x 8.04 x 13.05
						VAG92369 ■ 60.00 x 8.00 x 13.07
						VAG92445 ■ 60.00 x 8.00 x 13.04

<b>AY581</b> Fibre Composite, 1.300mm <b>AY591</b> Fibre Composite, 1.400mm <b>AB5101</b> Fibre Composite, 1200mm <b>AB5111</b> Fibre Composite, 1500mm	<b>DS381</b> ▲	<b>FB5100</b> ▲ [1]	<b>HBS011</b> ⊕ M12x1.25x119.00mm (x12)	<b>JC054</b> ■ <b>JC055</b> ■ JF123	<b>JN594</b>	<b>HR602</b> ■	<b>NPO68</b> 55.00x70.00x8.00mm FPM <b>NPO67</b> 50.00x70.00x10.00mm FPM

<b>AB5101</b> [1] Without crankshaft seal	<b>AB5111</b>	<b>AY581</b> [1] sans bague d'étanchéité - vilebrequin	<b>AY591</b> [1] senza paraolio-albero a gomiti			<b>HR602</b> ■ [1] sin cigüeñal retén

## 615

93.00

**Diesel**



8140.21.200 D.I.

4 Cyl.

18:1

2445cc

68kW (92)PS

Turbocharged

TD143

1253

B x C x D	OE	MAT.				E x F x G			
<b>V91292</b>	7 301 820		30°	Y	H	<b>VAG92193</b>			
40.80 x 8.00 x 120.70						56.00 x 8.04 x 13.05			
<b>V91293</b>	7 301 821		45°			<b>VAG92373</b>			
34.50 x 8.00 x 122.00						56.00 x 8.03 x 13.04			
<b>V91294</b>	7 302 157		45°		H	<b>VAG92444</b>			
34.50 x 8.00 x 122.00						56.00 x 8.00 x 13.04			
						<b>VAG92194</b>			
						60.00 x 8.04 x 13.05			
						<b>VAG92369</b>			
						60.00 x 8.00 x 13.07			
						<b>VAG92445</b>			
						60.00 x 8.00 x 13.04			

<b>BR071</b> Fibre Composite, 1200mm	<b>DS381</b>	<b>FB5100</b>	<b>HBS011</b>	<b>JC054</b>	<b>JN594</b>	<b>HR602</b>	<b>NP068</b>
<b>AB5111</b> Fibre Composite, 1500mm			M12x1.25x119.00mm (x12)	(x4)			55.00x70.00x8.00mm FPM
<b>AB5111</b>	<b>BR071</b>						
[1] Without crankshaft seal		[1] sans bague d'étanchéité - vilebrequin		[1] senza paraolio-albero a gomiti		[1] sin cigüeñal retén	

## 616

93.00

**Diesel**



8140.21.214

4 Cyl.

18:1

2445cc

77kW (105)PS

Turbocharged

TD1704

1255

B x C x D	OE	MAT.				E x F x G			
<b>V91292</b>	7 301 820		30°	Y	H	<b>VAG92193</b>			
40.80 x 8.00 x 120.70						56.00 x 8.04 x 13.05			
<b>V91293</b>	7 301 821		45°			<b>VAG92373</b>			
34.50 x 8.00 x 122.00						56.00 x 8.03 x 13.04			
<b>V91294</b>	7 302 157		45°		H	<b>VAG92444</b>			
34.50 x 8.00 x 122.00						56.00 x 8.00 x 13.04			
						<b>VAG92194</b>			
						60.00 x 8.04 x 13.05			
						<b>VAG92369</b>			
						60.00 x 8.00 x 13.07			
						<b>VAG92445</b>			
						60.00 x 8.00 x 13.04			

<b>AY591</b> Fibre Composite, 1.400mm	<b>DR073</b>	<b>FB5102</b>	<b>HBS011</b>	<b>JC054</b>	<b>JN594</b>	<b>HR602</b>	<b>NP068</b>
	<b>DS381</b>		M12x1.25x119.00mm (x12)				55.00x70.00x8.00mm FPM
							<b>NP067</b>
							50.00x70.00x10.00mm FPM
<b>AY591</b>							
[1] Without crankshaft seal		[1] sans bague d'étanchéité - vilebrequin		[1] senza paraolio-albero a gomiti		[1] sin cigüeñal retén	

<b>617</b>	<b>93.00</b>	<b>Diesel</b>					
<b>8140.27 S</b>	4 Cyl.	18:1	2445cc	<b>68kW (92)PS</b>	<b>Turbocharged</b>	<b>TD1705</b>	<b>1258</b>

<b>TB250</b> 153x30 Eng. → 1307400					

 B x C x D	OE	MAT.				 E x F x G
<b>V91292</b> ■ 40.80 x 8.00 x 120.70	7 301 820	 MB cr	30°	Y	H	<b>VAG92193</b> ■ 56.00 x 8.04 x 13.05
<b>V91293</b> ■ 34.50 x 8.00 x 122.00	7 301 821	 MD	45°			<b>VAG92373</b> ■ 56.00 x 8.03 x 13.04
<b>V91294</b> ■ 34.50 x 8.00 x 122.00	7 302 157	 MF cr	45°		H	<b>VAG92444</b> ■ 56.00 x 8.00 x 13.04
						<b>VAG92194</b> ■ 60.00 x 8.04 x 13.05
						<b>VAG92369</b> ■ 60.00 x 8.00 x 13.07
						<b>VAG92445</b> ■ 60.00 x 8.00 x 13.04

<b>AY581</b> Fibre Composite, 1.300mm <b>AY591</b> Fibre Composite, 1.400mm <b>AB5101</b> Fibre Composite, 1200mm <b>AB5111</b> Fibre Composite, 1500mm	<b>DS381</b> ▲	<b>FB5100</b> ▲ [1]	<b>HBS011</b> Ⓢ M12x1.25x119.00mm (x12)	<b>JC054</b> ■ <b>JC055</b> ■ JF123	<b>JN594</b>	<b>HR602</b> ■	<b>NP068</b> 55.00x70.00x8.00mm FPM

<b>AB5101</b> [1] Without crankshaft seal	<b>AB5111</b>	<b>AY581</b> [1] sans bague d'étanchéité - vilebrequin	<b>AY591</b> [1] senza paraolio-albero a gomiti
			<b>HR602</b> ■ [1] sin cigüeñal retén



8140.61      4 Cyl.      21:1      2445cc      53-55kW (72-75)PS      TD1050      1260

<b>TB135</b> 152x30 Polychloroprene (Neoprene)	<b>TBK045</b> Component No: TB135; AE1011TP;AE1010GP		<b>KIT</b>		

	OE	MAT.				
B x C x D						E x F x G
<b>V91292</b> ■ 40.80 x 8.00 x 120.70	7 301 820		30°	Y	H	
<b>V91293</b> ■ 34.50 x 8.00 x 122.00	7 301 821		45°			
<b>V91294</b> ■ 34.50 x 8.00 x 122.00	7 302 157		45°		H	

<b>AB5720</b> MLS, 1.100mm <b>AB5730</b> MLS, 1.200mm <b>AB5740</b> MLS, 1.300mm	<b>CB5720</b> ▲	<b>FB5721</b> ▲	<b>HBS251</b> ☉ M14x1.50x193.00mm (x6)	<b>JD5338</b> ■ <b>JD5337</b> ■	<b>JM5201</b> (Steel Elastomer)	<b>HR602</b> ■	<b>NP068</b> 55.00x70.00x8.00mm FPM



AB5720, AB5730, AB5740



## 619

## 93.00

## Diesel



8140.61.200

4 Cyl.

21:1

2445cc

53kW (72)PS

TD144

1261

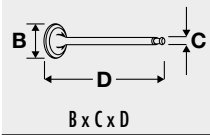

OE

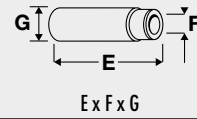

B x C x D	OE	MAT.	Angle	Y	H	E x F x G
<b>V91292</b> ■ 40.80 x 8.00 x 120.70	7 301 820	MB cr	30°	Y	H	<b>VAG92193</b> ■ 56.00 x 8.04 x 13.05
<b>V91293</b> ■ 34.50 x 8.00 x 122.00	7 301 821	MD	45°			<b>VAG92373</b> ■ 56.00 x 8.03 x 13.04
<b>V91294</b> ■ 34.50 x 8.00 x 122.00	7 302 157	MF cr	45°		H	<b>VAG92444</b> ■ 56.00 x 8.00 x 13.04
						<b>VAG92194</b> ■ 60.00 x 8.04 x 13.05
						<b>VAG92369</b> ■ 60.00 x 8.00 x 13.07
						<b>VAG92445</b> ■ 60.00 x 8.00 x 13.04

<b>BE580</b> Fibre Composite, 1.350mm	<b>DE588</b> ▲	<b>FY291</b> ▲ [1]	<b>HBS011</b> ① M12x1.25x119.00mm (x12)	<b>JC054</b> ■ <b>JC055</b> ■	<b>JN594</b>	<b>HR602</b> ■ (x8)	<b>NP068</b> 55.00x70.00x8.00mm FPM <b>NP067</b> 50.00x70.00x10.00mm FPM



**BE580**

[1] Without crankshaft seal

[1] sans bague d'étanchéité - vilebrequin

[1] senza paraolio-albero a gomiti

[1] sin cigüeñal retén

**620**

**93.00**

**Diesel**



8140.61.200

4 Cyl.

21:1

2445cc

53kW (72)PS

TD7225

1262



KIT



**TB135**  
152x30  
Polychloroprene (Neoprene)

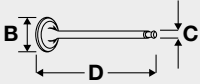

B x C x D

OE



MAT.



30°

Y

H

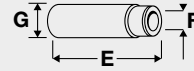

E x F x G

**V91292** ■  
40.80 x 8.00 x 120.70

7 301 820

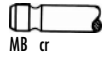

MB cr

**V91293** ■  
34.50 x 8.00 x 122.00

7 301 821

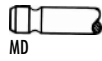

MD

**V91294** ■  
34.50 x 8.00 x 122.00

7 302 157

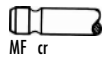

MF cr

**VAG92193** ■  
56.00 x 8.04 x 13.05



**VAG92373** ■  
56.00 x 8.03 x 13.04



**VAG92444** ■  
56.00 x 8.00 x 13.04

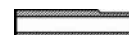

**VAG92194** ■  
60.00 x 8.04 x 13.05



**VAG92369** ■  
60.00 x 8.00 x 13.07



**VAG92445** ■  
60.00 x 8.00 x 13.04

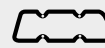

**BE580** Fibre Composite, 1.350mm

**FY291** ▲ [1]

**HBS011** ①  
M12x1.25x119.00mm (x12)

**JC054** ■  
**JC055** ■

**JN594**

**HR602** ■

**NP067** ■  
50.00x70.00x10.00mm FPM

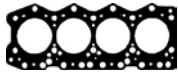

**BE580**

[1] Without crankshaft seal

[1] sans bague d'étanchéité - vilebrequin

[1] senza paraolio-albero a gomiti

[1] sin cigüeñal retén

## 621

 **93.00**

**Diesel**



8140.61.204

4 Cyl.

21:1

2445cc

53kW (72)PS

TD1051

1259

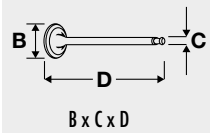

OE



MAT.

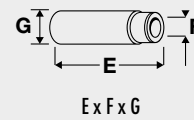

B x C x D	OE	MAT.	Angle	Thread	Nut	E x F x G
<b>V91292</b>	7 301 820		30°	Y	H	<b>VAG92193</b> 56.00 x 8.04 x 13.05
<b>V91293</b>	7 301 821		45°			<b>VAG92373</b> 56.00 x 8.03 x 13.04
<b>V91294</b>	7 302 157		45°		H	<b>VAG92444</b> 56.00 x 8.00 x 13.04
						<b>VAG92194</b> 60.00 x 8.04 x 13.05
						<b>VAG92369</b> 60.00 x 8.00 x 13.07
						<b>VAG92445</b> 60.00 x 8.00 x 13.04

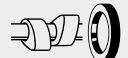
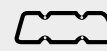

<b>BE580</b> Fibre Composite, 1.350mm 01/79 → →Eng.1051188	<b>DS381</b> ▲	<b>FB5721</b> ▲		<b>JC054</b> <b>JC055</b>	<b>JN462</b> 01/79 → →Eng.1051188 <b>JN594</b> 01/89 →	<b>HR602</b>	<b>NP068</b> 55.00x70.00x8.00mm FPM
<b>AY290</b> Fibre Composite, 1.600mm 01/89 → Eng.1051189 →							
<b>AY300</b> Fibre Composite, 1.700mm 01/89 → Eng.1051189 →							
<b>AY310</b> Fibre Composite, 1.800mm 01/89 → Eng.1051189 →							



AY290, AY300, AY310

BE580

# FIAT GROUP

**622**

 **93.00**

**Diesel**



8140.61.300

4 Cyl.







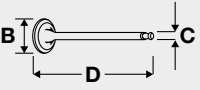
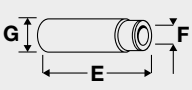

21:1

2445cc

53kW (72)PS

TD20426

**1263**

									
B x C x D	OE	MAT.	Angle	Part	E x F x G				
<b>V90402</b> ■	4 733 348		30°	H	<b>VAG92373</b> ■				
41.00 x 8.00 x 122.00		MG			56.00 x 8.03 x 13.04				
<b>V91292</b> ■	7 301 820		30°	Y	<b>VAG92444</b> ■				
40.80 x 8.00 x 120.70		MB cr			56.00 x 8.00 x 13.04				
<b>V90404</b> ■	4 733 349		45°	H	<b>VAG92369</b> ■				
33.00 x 8.00 x 122.00		MG			60.00 x 8.00 x 13.07				
<b>V91293</b> ■	7 301 821		45°		<b>VAG92445</b> ■				
34.50 x 8.00 x 122.00		MD			60.00 x 8.00 x 13.04				

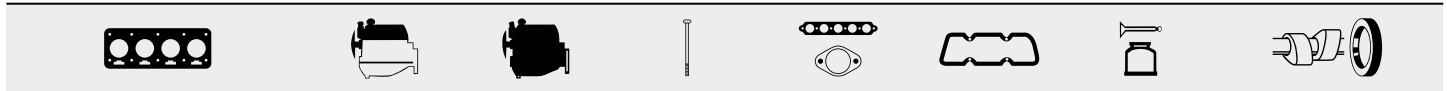

<b>BE580</b> Fibre Composite, 1.350mm	<b>FY291</b> ▲ [1]	<b>HBS011</b> ⊕ M12x1.25x119.00mm (x12)	<b>JC054</b> ■ <b>JC055</b> ■	<b>JN594</b>	<b>NPO68</b> 55.00x70.00x8.00mm FPM
---------------------------------------	--------------------	--	----------------------------------	--------------	--



**BE580**  
 [1] Without crankshaft seal      [1] sans bague d'étanchéité - vilebrequin      [1] senza paraolio-albero a gomiti      [1] sin cigüeñal retén

**623**

 **93.00**

**Diesel**



8142.61

4 Cyl.







21:1

2445cc

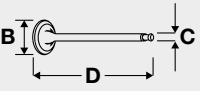
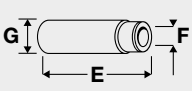
53kW (72)PS

TD1053

**1264**

									
B x C x D	OE	MAT.	Angle	Part	E x F x G				
<b>V90402</b> ■	4 733 348		30°	H	<b>VAG92193</b> ■				
41.00 x 8.00 x 122.00		MG			56.00 x 8.04 x 13.05				
<b>V90404</b> ■	4 733 349		45°	H	<b>VAG92444</b> ■				
33.00 x 8.00 x 122.00		MG			56.00 x 8.00 x 13.04				
					<b>VAG92194</b> ■				
					60.00 x 8.04 x 13.05				
					<b>VAG92445</b> ■				
					60.00 x 8.00 x 13.04				

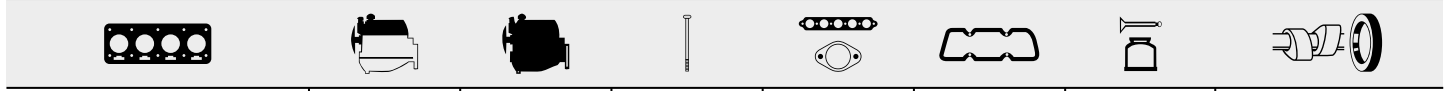

<b>BE580</b> Fibre Composite, 1.350mm	<b>JC054</b> ■	<b>NPO68</b> 55.00x70.00x8.00mm FPM
---------------------------------------	----------------	--



**BE580**

<b>624</b>	<b>93.00</b>	<b>Diesel</b>					
8144.21	4 Cyl.	18:1	2445cc	68kW (92)PS	Turbocharged	TD4419	1265

<b>TB250</b> 153x30 09/86→	<b>TBK063</b> 09/86→ Component No: TB250; AE1010GP		<b>KIT</b>		

	OE	MAT.				
B x C x D						E x F x G
<b>V91292</b> ■	7 301 820		30°	Y	H	
40.80 x 8.00 x 120.70		MB cr				56.00 x 8.04 x 13.05
<b>V91293</b> ■	7 301 821		45°			
34.50 x 8.00 x 122.00		MD				56.00 x 8.03 x 13.04
<b>V91294</b> ■	7 302 157		45°		H	
34.50 x 8.00 x 122.00		MF cr				56.00 x 8.00 x 13.04
						60.00 x 8.04 x 13.05
						60.00 x 8.00 x 13.07
						60.00 x 8.00 x 13.04

<b>BR071</b> Fibre Composite, 1200mm	<b>DS381</b> ▲	<b>FB5100</b> ▲ [1]	<b>HBS011</b> Ⓢ M12x1.25x119.00mm (x12)	<b>JC054</b> ■ <b>JC055</b> ■	<b>JN594</b>	<b>HR602</b> ■	<b>NP068</b> 55.00x70.00x8.00mm FPM



**BR071**

[1] Without crankshaft seal                      [1] sans bague d'étanchéité - vilebrequin                      [1] senza paraolio-albero a gomiti                      [1] sin cigüeñal retén

**625**

 **93.00**

**Diesel**



8144.21.220

4 Cyl.

18:1









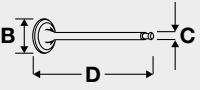
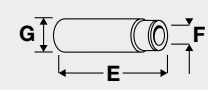

2445cc







68kW (92)PS

Turbocharged

TD145

1253

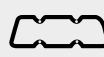
								
B x C x D	OE	MAT.				E x F x G		
<b>V91292</b> ■	7 301 820		30°	Y	H	<b>VAG92193</b> ■		
40.80 x 8.00 x 120.70		MB cr				56.00 x 8.04 x 13.05		
<b>V91293</b> ■	7 301 821		45°			<b>VAG92373</b> ■		
34.50 x 8.00 x 122.00		MD				56.00 x 8.03 x 13.04		
<b>V91294</b> ■	7 302 157		45°		H	<b>VAG92444</b> ■		
34.50 x 8.00 x 122.00		MF cr				56.00 x 8.00 x 13.04		
						<b>VAG92194</b> ■		
						60.00 x 8.04 x 13.05		
						<b>VAG92369</b> ■		
						60.00 x 8.00 x 13.07		
						<b>VAG92445</b> ■		
						60.00 x 8.00 x 13.04		

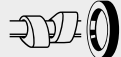
							
<b>BR071</b> Fibre Composite, 1200mm	<b>DS381</b> ▲	<b>FB5100</b> ▲ [1]	<b>HBS011</b> Ⓢ M12x1.25x119.00mm (x12)	<b>JC054</b> ■	<b>JN594</b>	<b>HR602</b> ■	<b>NP068</b> 55.00x70.00x8.00mm FPM



**BR071**  
 [1] Without crankshaft seal                      [1] sans bague d'étanchéité - vilebrequin                      [1] senza paraolio-albero a gomiti                      [1] sin cigüeñal retén

<b>626</b>	<b>93.00</b>	<b>Diesel</b>					
8144.21.220	4 Cyl.	18:1	2445cc	68kW (92)PS	Turbocharged	TD6803	1266
<b>TB250</b> 153x30	<b>TBK063</b> Component No: TB250; AE1010GP						

	OE	MAT.				
B x C x D						E x F x G
<b>V91292</b> ■ 40.80 x 8.00 x 120.70	7 301 820	 MB cr	30°	Y	H	<b>VAG92193</b> ■ 56.00 x 8.04 x 13.05
<b>V91293</b> ■ 34.50 x 8.00 x 122.00	7 301 821	 MD	45°			<b>VAG92373</b> ■ 56.00 x 8.03 x 13.04
<b>V91294</b> ■ 34.50 x 8.00 x 122.00	7 302 157	 MF cr	45°		H	<b>VAG92444</b> ■ 56.00 x 8.00 x 13.04
						<b>VAG92194</b> ■ 60.00 x 8.04 x 13.05
						<b>VAG92369</b> ■ 60.00 x 8.00 x 13.07
						<b>VAG92445</b> ■ 60.00 x 8.00 x 13.04

<b>BR071</b> Fibre Composite, 1200mm		<b>FB5100</b> ▲ [1]	<b>HBS011</b> ⊕ M12x1.25x119.00mm (x12)	<b>JC054</b> ■ <b>JC055</b> ■ <b>JC706</b> ■ (x3)	<b>JN594</b>	<b>HR602</b> ■	<b>NP068</b> 55.00x70.00x8.00mm FPM <b>NP067</b> 50.00x70.00x10.00mm FPM



**BR071**  
 [1] Without crankshaft seal      [1] sans bague d'étanchéité - vilebrequin      [1] senza paraolio-albero a gomiti      [1] sin cigüeñal retén

<b>627</b>	<b>93.00</b>	<b>Diesel</b>				
8144.61	4 Cyl.	22:1	2445cc	53kW (72)PS	FM566	1267
	OE	MAT.				
B x C x D						E x F x G
<b>V91292</b> ■ 40.80 x 8.00 x 120.70	7 301 820	 MB cr	30°	Y	H	<b>VAG92193</b> ■ 56.00 x 8.04 x 13.05
<b>V90404</b> ■ 33.00 x 8.00 x 122.00	4 733 349	 MG	45°		H	<b>VAG92373</b> ■ 56.00 x 8.03 x 13.04
<b>V91293</b> ■ 34.50 x 8.00 x 122.00	7 301 821	 MD	45°			<b>VAG92444</b> ■ 56.00 x 8.00 x 13.04
						<b>VAG92194</b> ■ 60.00 x 8.04 x 13.05
						<b>VAG92369</b> ■ 60.00 x 8.00 x 13.07
						<b>VAG92445</b> ■ 60.00 x 8.00 x 13.04

## 628

### 93.00

### Diesel



8144.61.200

4 Cyl.

22:1

2445cc

53kW (72)PS

TD6796

1268

B x C x D	OE	MAT.	Angle	Tip		E x F x G
<b>V90402</b> ■	4 733 348		30°	H		<b>VAG92193</b> ■
41.00 x 8.00 x 122.00		MG				56.00 x 8.04 x 13.05
<b>V91292</b> ■	7 301 820		30°	Y	H	<b>VAG92373</b> ■
40.80 x 8.00 x 120.70		MB cr				56.00 x 8.03 x 13.04
<b>V90404</b> ■	4 733 349		45°	H		<b>VAG92444</b> ■
33.00 x 8.00 x 122.00		MG				56.00 x 8.00 x 13.04
<b>V91293</b> ■	7 301 821		45°			<b>VAG92194</b> ■
34.50 x 8.00 x 122.00		MD				60.00 x 8.04 x 13.05
						<b>VAG92369</b> ■
						60.00 x 8.00 x 13.07
						<b>VAG92445</b> ■
						60.00 x 8.00 x 13.04

BE580 Fibre Composite, 1.350mm	DE588 ▲	FY291 ▲ [1]	HBS011 ⊕ M12x1.25x119.00mm (x12)	JC054 ■ JC055 ■	JN462 →Eng.574798 JN594	HR662 ■	NP068 55.00x70.00x8.00mm FPM



BE580  
 [1] Without crankshaft seal      [1] sans bague d'étanchéité - vilebrequin      [1] senza paraolio-albero a gomiti      [1] sin cigüeñal retén

## 629

### 93.00

### Diesel



8144.61.200

4 Cyl.

22:1

2445cc

53kW (72)PS

TD20429

1269

B x C x D	OE	MAT.	Angle	Tip		E x F x G
<b>V90402</b> ■	4 733 348		30°	H		<b>VAG92193</b> ■
41.00 x 8.00 x 122.00		MG				56.00 x 8.04 x 13.05
<b>V91292</b> ■	7 301 820		30°	Y	H	<b>VAG92373</b> ■
40.80 x 8.00 x 120.70		MB cr				56.00 x 8.03 x 13.04
<b>V90404</b> ■	4 733 349		45°	H		<b>VAG92444</b> ■
33.00 x 8.00 x 122.00		MG				56.00 x 8.00 x 13.04
<b>V91293</b> ■	7 301 821		45°			<b>VAG92194</b> ■
34.50 x 8.00 x 122.00		MD				60.00 x 8.04 x 13.05
						<b>VAG92369</b> ■
						60.00 x 8.00 x 13.07
						<b>VAG92445</b> ■
						60.00 x 8.00 x 13.04

					JC054 ■		
--	--	--	--	--	---------	--	--



<b>630</b>	<b>93.00</b>	<b>Diesel</b>							
8144.61.200	4 Cyl.	22:1	2445cc	53kW (72)PS				TD146	1261

 B x C x D					 E x F x G				
OE	MAT.				OE	MAT.			
<b>V90402</b>	4 733 348		30°	H	<b>VAG92193</b>				
41.00 x 8.00 x 122.00		MG			56.00 x 8.04 x 13.05				
<b>V91292</b>	7 301 820		30°	Y	<b>VAG92373</b>				
40.80 x 8.00 x 120.70		MB cr			56.00 x 8.03 x 13.04				
<b>V90404</b>	4 733 349		45°	H	<b>VAG92444</b>				
33.00 x 8.00 x 122.00		MG			56.00 x 8.00 x 13.04				
<b>V91293</b>	7 301 821		45°		<b>VAG92194</b>				
34.50 x 8.00 x 122.00		MD			60.00 x 8.04 x 13.05				
					<b>VAG92369</b>				
					60.00 x 8.00 x 13.07				
					<b>VAG92445</b>				
					60.00 x 8.00 x 13.04				

BE580 Fibre Composite, 1.350mm	DE588 ▲	FY291 ▲ [1]	HBS011 ⊕ M12x1.25x119.00mm (x12)	JC054 JC055	JN594	HR602  (x8) HR782	NPO68 55.00x70.00x8.00mm FPM



BE580  
 [1] Without crankshaft seal      [1] sans bague d'étanchéité - vilebrequin      [1] senza paraolio-albero a gomiti      [1] sin cigüeñal retén

<b>631</b>	<b>93.00</b>	<b>Diesel</b>							
8144.61.500.81	4 Cyl.	22:1	2445cc	66kW (90)PS	<b>Turbocharged</b>			TD1054	1270

<b>TB135</b> 152x30 Polychloroprene (Neoprene)	<b>TBK045</b> Component No: TB135; AE1011TP;AE1010GP		<b>KIT</b>			

 B x C x D					 E x F x G				
OE	MAT.				OE	MAT.			
<b>V90402</b>	4 733 348		30°	H	<b>VAG92193</b>				
41.00 x 8.00 x 122.00		MG			56.00 x 8.04 x 13.05				
<b>V91292</b>	7 301 820		30°	Y	<b>VAG92373</b>				
40.80 x 8.00 x 120.70		MB cr			56.00 x 8.03 x 13.04				
<b>V90404</b>	4 733 349		45°	H	<b>VAG92444</b>				
33.00 x 8.00 x 122.00		MG			56.00 x 8.00 x 13.04				
<b>V91293</b>	7 301 821		45°		<b>VAG92194</b>				
34.50 x 8.00 x 122.00		MD			60.00 x 8.04 x 13.05				
					<b>VAG92369</b>				
					60.00 x 8.00 x 13.07				
					<b>VAG92445</b>				
					60.00 x 8.00 x 13.04				

DE588 ▲	HBS011 ⊕ M12x1.25x119.00mm (x12)	JC055	JN594	NPO68 55.00x70.00x8.00mm FPM

**632**

 **93.00**

**Diesel**



8144.81.2000

4 Cyl.











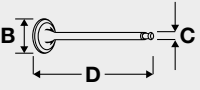
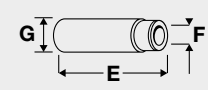











22:1

2445cc

66-74kW (90-101)PS

TD1057

1259

								
B x C x D	OE	MAT.				E x F x G		
<b>V91292</b> 	7 301 820		30°	Y	H	<b>VAG92193</b> 		
40.80 x 8.00 x 120.70		MB cr				56.00 x 8.04 x 13.05		
<b>V91293</b> 	7 301 821		45°			<b>VAG92373</b> 		
34.50 x 8.00 x 122.00		MD				56.00 x 8.03 x 13.04		
<b>V91294</b> 	7 302 157		45°		H	<b>VAG92444</b> 		
34.50 x 8.00 x 122.00		MF cr				56.00 x 8.00 x 13.04		
						<b>VAG92194</b> 		
						60.00 x 8.04 x 13.05		
						<b>VAG92369</b> 		
						60.00 x 8.00 x 13.07		
						<b>VAG92445</b> 		
						60.00 x 8.00 x 13.04		

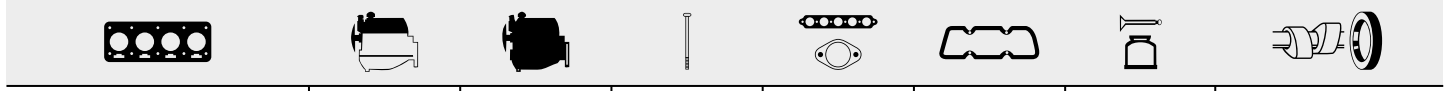









BE580 Fibre Composite, 1.350mm











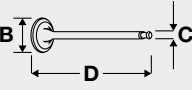



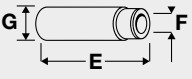

JC054 













BE580

<b>633</b>	 <b>93.00</b>	<b>Diesel</b>					
8144.91	4 Cyl.	22:1	2445cc	74kW (101)PS	Turbocharged	TD4600	1271

					
<b>TB348</b>					
99x19					

	OE	MAT.				
B x C x D						E x F x G
<b>V91292</b> 	7 301 820		30°	Y	H	
40.80 x 8.00 x 120.70		MB cr				56.00 x 8.04 x 13.05
<b>V91293</b> 	7 301 821		45°			
34.50 x 8.00 x 122.00		MD				56.00 x 8.03 x 13.04
<b>V91294</b> 	7 302 157		45°		H	
34.50 x 8.00 x 122.00		MF cr				56.00 x 8.00 x 13.04
						
						60.00 x 8.04 x 13.05
						
						60.00 x 8.00 x 13.07
						
						60.00 x 8.00 x 13.04

							
<b>BR090</b> Fibre Composite, 1.800mm	<b>DP273</b> ▲	<b>FB5722</b> ▲	<b>HBS011</b> Ⓢ M12x1.25x119.00mm (x12)	<b>JC054</b>  <b>JC055</b> 	<b>JN585</b>	<b>HR602</b> 	<b>NF841</b> 35.00x50.00x8.00mm FPM <b>NP068</b> 55.00x70.00x8.00mm FPM



BR090

**634**

 **93.00**

**Diesel**



8144.91.2000

4 Cyl.

22:1

2445cc

74kW (101)PS

Turbo Intercooled

TD1058

**1272**



**TB348**  
99x19

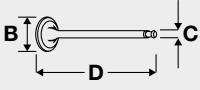

B x C x D

OE



MAT.



30°

Y

H

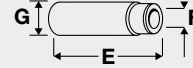

E x F x G

**V91292**   
40.80 x 8.00 x 120.70

7 301 820

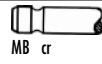

MB cr

**V91293**   
34.50 x 8.00 x 122.00

7 301 821

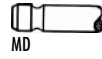

MD

**V91294**   
34.50 x 8.00 x 122.00

7 302 157

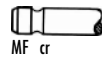

MF cr

**VAG92193** 

56.00 x 8.04 x 13.05

**VAG92373** 

56.00 x 8.03 x 13.04

**VAG92444** 

56.00 x 8.00 x 13.04

**VAG92194** 

60.00 x 8.04 x 13.05

**VAG92369** 

60.00 x 8.00 x 13.07

**VAG92445** 

60.00 x 8.00 x 13.04

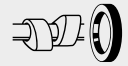
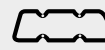

**BR090** Fibre Composite, 1.800mm

**DP273** 

**HBS011** 

M12x1.25x119.00mm (x12)

**JC054** 

**JC055** 

**JN585**



**HR602** 

**NP068** 





55.00x70.00x8.00mm FPM



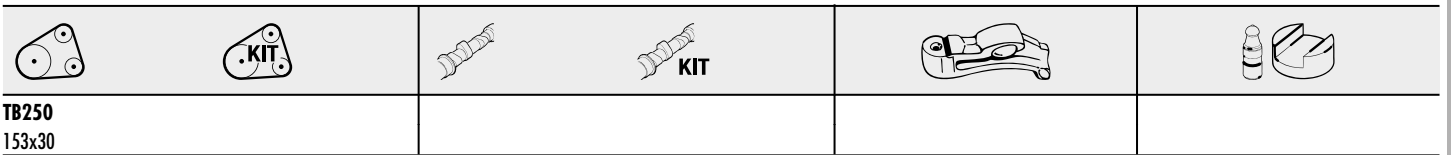

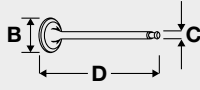
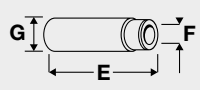
**BR090**





**635**  **93.00** **Diesel**   
**8140.07.2700** 4 Cyl. 18:1 2499cc **55kW (75)PS** **TD1700** **1275**

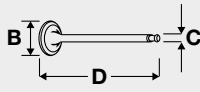
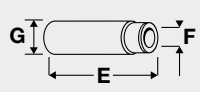

 B x C x D				 E x F x G			
OE	MAT.	Angle	Material	OE	MAT.	Angle	Material
<b>V91399</b> ■ 41.00 x 8.00 x 122.00	4 813 760	MB	30°	H	<b>VAG92193</b> ■ 56.00 x 8.04 x 13.05		
<b>V91400</b> ■ 34.50 x 8.00 x 122.00	7 303 309	MG	45°	H	<b>VAG92373</b> ■ 56.00 x 8.03 x 13.04		
					<b>VAG92369</b> ■ 60.00 x 8.00 x 13.07		
					<b>VAG92445</b> ■ 60.00 x 8.00 x 13.04		

Part	Part	Part	Part	Part	Part	Part	Part
<b>AY581</b> Fibre Composite, 1.300mm <b>AY591</b> Fibre Composite, 1.400mm <b>AB5101</b> Fibre Composite, 1200mm <b>AB5111</b> Fibre Composite, 1500mm	<b>DS381</b> ▲	<b>FB5101</b> ▲ [1]	<b>HBS011</b> Ⓢ M12x1.25x119.00mm (x12)	<b>JC054</b> ■ <b>JC055</b> ■	<b>JN594</b>	<b>HR602</b> ■	<b>NPO68</b> 55.00x70.00x8.00mm FPM <b>NPO67</b> 50.00x70.00x10.00mm FPM
							
<b>AB5101</b> [1] Without crankshaft seal	<b>AB5111</b>	<b>AY581</b> [1] sans bague d'étanchéité - vilebrequin	<b>AY591</b> [1] senza paraolio-albero a gomiti				<b>HR602</b> [1] sin cigüeñal retén

**636**  **93.00** **Diesel**   
**8140.07.2701** 4 Cyl. 18:1 2499cc **55kW (75)PS** **TD1701** **1276**

 B x C x D				 E x F x G			
OE	MAT.	Angle	Material	OE	MAT.	Angle	Material
<b>V91399</b> ■ 41.00 x 8.00 x 122.00	4 813 760	MB	30°	H	<b>VAG92193</b> ■ 56.00 x 8.04 x 13.05		
<b>V91400</b> ■ 34.50 x 8.00 x 122.00	7 303 309	MG	45°	H	<b>VAG92373</b> ■ 56.00 x 8.03 x 13.04		
					<b>VAG92369</b> ■ 60.00 x 8.00 x 13.07		
					<b>VAG92445</b> ■ 60.00 x 8.00 x 13.04		

Part	Part	Part	Part	Part	Part	Part	Part
<b>AY581</b> Fibre Composite, 1.300mm <b>AY591</b> Fibre Composite, 1.400mm <b>AB5101</b> Fibre Composite, 1200mm <b>AB5111</b> Fibre Composite, 1500mm			<b>HBS011</b> Ⓢ M12x1.25x119.00mm (x12)	<b>JC054</b> ■ <b>JC055</b> ■			<b>NPO68</b> 55.00x70.00x8.00mm FPM <b>NPO67</b> 50.00x70.00x10.00mm FPM
							
<b>AB5101</b>	<b>AB5111</b>	<b>AY581</b>	<b>AY591</b>				

# FIAT GROUP

## 637



93.00

Diesel



8140.07.2712

4 Cyl.

18:1

2499cc

55kW (75)PS

TD1702

1278



TB250  
153x30

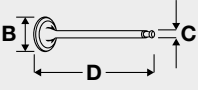

B x C x D

OE



MAT.



30°



H



E x F x G

V91399 ■  
41.00 x 8.00 x 122.00

4 813 760



MB

V91400 ■  
34.50 x 8.00 x 122.00

7 303 309

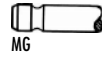

MG

45°

H

VAG92193 ■  
56.00 x 8.04 x 13.05



VAG92373 ■  
56.00 x 8.03 x 13.04



VAG92369 ■  
60.00 x 8.00 x 13.07



VAG92445 ■  
60.00 x 8.00 x 13.04

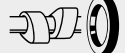
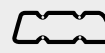

AY581 Fibre Composite, 1.300mm  
AY591 Fibre Composite, 1.400mm  
AB5101 Fibre Composite, 1200mm  
AB5111 Fibre Composite, 1500mm

DS381 ▲

FB5101 ▲ [1]

HBS011 Ⓢ  
M12x1.25x119.00mm (x12)

JC054 ■  
JC055 ■

JN594

HR602 ■

NP068  
55.00x70.00x8.00mm FPM



AB5101

AB5111

AY581

AY591

[1] Without crankshaft seal

[1] sans bague d'étanchéité - vilebrequin

[1] senza paraolio-albero a gomiti

[1] sin cigüeñal retén

## 638



93.00

Diesel



8140.07.3710 Euro 1

4 Cyl.

19:1

2499cc

53kW (72)PS

TD20418

1280

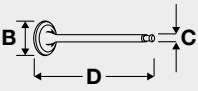

B x C x D

OE



MAT.



30°



H

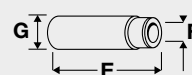

E x F x G

V91399 ■  
41.00 x 8.00 x 122.00

4 813 760



MB

V91400 ■  
34.50 x 8.00 x 122.00

7 303 309

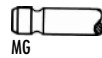

MG

45°

H

VAG92193 ■  
56.00 x 8.04 x 13.05



VAG92373 ■  
56.00 x 8.03 x 13.04



VAG92369 ■  
60.00 x 8.00 x 13.07



VAG92445 ■  
60.00 x 8.00 x 13.04

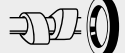
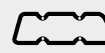

AY591 Fibre Composite, 1.400mm

DS381 ▲

JC054 ■  
JC055 ■

JN594

NP068  
55.00x70.00x8.00mm FPM



AY591









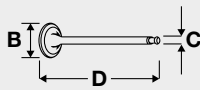
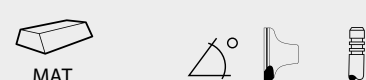
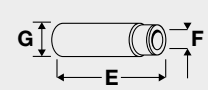
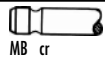

## 639

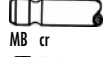
 **93.00**

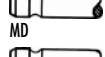
### Diesel

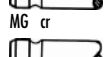

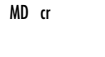
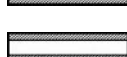
8140.27.215	4 Cyl.	18.5:1	2499cc	76kW (103)PS	Turbocharged	TD27387	1277
8140.27.218	4 Cyl.	18.5:1	2499cc	76kW (103)PS	Turbocharged	TD26268	1281
8140.27S.2701	4 Cyl.	18:1	2499cc	76kW (103)PS	Turbocharged	TD27396	1277
8140.27S.2710	4 Cyl.	18:1	2499cc	76kW (103)PS	Turbocharged	TD27397	1277
8140.27S.2711	4 Cyl.	18:1	2499cc	76kW (103)PS	Turbocharged	TD27398	1277
8140.27S.2720	4 Cyl.	18:1	2499cc	76kW (103)PS	Turbocharged	TD27399	1277
8140.27S.2721	4 Cyl.	18:1	2499cc	76kW (103)PS	Turbocharged	TD27400	1277
8140.27S.2730	4 Cyl.	18:1	2499cc	76kW (103)PS	Turbocharged	TD27401	1277
8140.27S.2731	4 Cyl.	18:1	2499cc	76kW (103)PS	Turbocharged	TD27402	1277
8140.27S.2750	4 Cyl.	18:1	2499cc	76kW (103)PS	Turbocharged	TD27403	1277
8140.27S.2770	4 Cyl.	18:1	2499cc	76kW (103)PS	Turbocharged	TD27407	1277
8140.27S.2771	4 Cyl.	18:1	2499cc	76kW (103)PS	Turbocharged	TD27408	1277
8140.27S.2811	4 Cyl.	18:1	2499cc	76kW (103)PS	Turbocharged	TD27409	1277
8140.27S.3701	4 Cyl.	18.5:1	2499cc	77kW (104)PS	Turbocharged	TD27411	1277
8140.27S.3711	4 Cyl.	18.5:1	2499cc	77kW (104)PS	Turbocharged	TD27412	1277
8140.27S.3720	4 Cyl.	18.5:1	2499cc	77kW (104)PS	Turbocharged	TD27413	1277
8140.27S.3721	4 Cyl.	18.5:1	2499cc	77kW (104)PS	Turbocharged	TD27414	1277
8140.27S.3750	4 Cyl.	18.5:1	2499cc	77kW (104)PS	Turbocharged	TD27415	1277
8140.27S.3751	4 Cyl.	18.5:1	2499cc	77kW (104)PS	Turbocharged	TD27416	1277
8140.27S.3760	4 Cyl.	18.5:1	2499cc	77kW (104)PS	Turbocharged	TD27419	1277
8140.27S.3761	4 Cyl.	18.5:1	2499cc	77kW (104)PS	Turbocharged	TD27420	1277
8140.27S.3771	4 Cyl.	18.5:1	2499cc	77kW (104)PS	Turbocharged	TD27423	1277
8140.27S.3780	4 Cyl.	18.5:1	2499cc	77kW (104)PS	Turbocharged	TD27424	1277
8140.47.3721 Euro I	4 Cyl.	18.5:1	2499cc	85kW (116)PS	Turbo Intercooled	TD26006	1296
8140.47B.3790 Euro I	4 Cyl.	18.5:1	2499cc	78-83kW (106-113)PS	Turbo Intercooled	TD26008	1296
8140.47B.3795 Euro I	4 Cyl.	18.5:1	2499cc	78-83kW (106-113)PS	Turbo Intercooled	TD26009	1296
8140.47R.2795	4 Cyl.	18.5:1	2499cc	80kW (109)PS	Turbo Intercooled	TD26010	1296

							
B x C x D	OE	MAT.				E x F x G	
<b>V91292</b> ■ 40.80 x 8.00 x 120.70	7 301 820	 MB cr	30°	Y	H	<b>VAG92193</b> ■ 56.00 x 8.04 x 13.05	
<b>V91939</b> ■ 43.50 x 8.00 x 122.00	98 468 338	 MB cr	30°		H	<b>VAG92373</b> ■ 56.00 x 8.03 x 13.04	
<b>V91293</b> ■ 34.50 x 8.00 x 122.00	7 301 821	 MD	45°			<b>VAG92444</b> ■ 56.00 x 8.00 x 13.04	
<b>V91940</b> ■ 36.70 x 8.00 x 122.00	98 418 161	 MG cr	45°		H	<b>VAG92194</b> ■ 60.00 x 8.04 x 13.05	
<b>V91994</b> ■ 35.80 x 8.00 x 121.90	99 432 837	 MD cr	45°			<b>VAG92369</b> ■ 60.00 x 8.00 x 13.07	
						<b>VAG92445</b> ■ 60.00 x 8.00 x 13.04	

**640**

 **93.00**

**Diesel**



8140.27.2582

4 Cyl.

18.5:1

2499cc

74-79kW (101-107)PS

Turbocharged

TD7260

**1282**

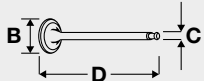

B x C x D





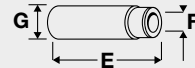

OE















MAT.



E x F x G

<b>V91292</b> 	7 301 820		30°	Y	H
40.80 x 8.00 x 120.70		MB cr			
<b>V91293</b> 	7 301 821		45°		
34.50 x 8.00 x 122.00		MD			
<b>V91294</b> 	7 302 157		45°		H
34.50 x 8.00 x 122.00		MF cr			

<b>VAG92193</b> 	
56.00 x 8.04 x 13.05	
<b>VAG92373</b> 	
56.00 x 8.03 x 13.04	
<b>VAG92444</b> 	
56.00 x 8.00 x 13.04	
<b>VAG92194</b> 	
60.00 x 8.04 x 13.05	
<b>VAG92369</b> 	
60.00 x 8.00 x 13.07	
<b>VAG92445</b> 	
60.00 x 8.00 x 13.04	

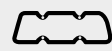

DS381 ▲

JC054 ■



## 641

## 93.00

## Diesel



8140.27.2700	4 Cyl.	18:1	2499cc	76kW (103)PS	Turbocharged	TD1706	1283
8140.27.2720	4 Cyl.	18:1	2499cc	76kW (103)PS		TD1707	1284
8140.47.2711 Euro 1	4 Cyl.	18:1	2499cc	85kW (116)PS	Turbocharged	TD1712	1292

<b>TB250</b> 153x30 Eng.→1307400					

 B x C x D				 E x F x G		
OE	MAT.	Angle	Y	H	Ex F x G	
<b>V91292</b> ■ 40.80 x 8.00 x 120.70	7 301 820 MB cr	30°	Y	H	<b>VAG92193</b> ■ 56.00 x 8.04 x 13.05	
<b>V91293</b> ■ 34.50 x 8.00 x 122.00	7 301 821 MD	45°			<b>VAG92373</b> ■ 56.00 x 8.03 x 13.04	
<b>V91294</b> ■ 34.50 x 8.00 x 122.00	7 302 157 MF cr	45°		H	<b>VAG92444</b> ■ 56.00 x 8.00 x 13.04	
					<b>VAG92194</b> ■ 60.00 x 8.04 x 13.05	
					<b>VAG92369</b> ■ 60.00 x 8.00 x 13.07	
					<b>VAG92445</b> ■ 60.00 x 8.00 x 13.04	

<b>AY581</b> Fibre Composite, 1.300mm <b>AY591</b> Fibre Composite, 1.400mm <b>AB5101</b> Fibre Composite, 1200mm <b>AB5111</b> Fibre Composite, 1500mm	<b>DS381</b> ▲	<b>FB5101</b> ▲ [1]	<b>HBS011</b> ◊ M12x1.25x119.00mm (x12)	<b>JC054</b> ■ <b>JC055</b> ■	<b>JN594</b>	<b>HR602</b> ■	<b>NP068</b> 55.00x70.00x8.00mm FPM

<b>AB5101</b> [1] Without crankshaft seal	<b>AB5111</b>	<b>AY581</b> [1] sans bague d'étanchéité - vilebrequin	<b>AY591</b> [1] senza paraolio-albero a gomiti		<b>HR602</b> ■ [1] sin cigüeñal retén

## 642

 93.00

**Diesel**



8140.27.2811

4 Cyl.











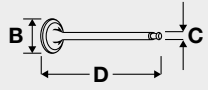
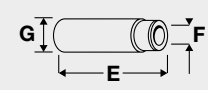











18:1











2499cc

76kW (103)PS

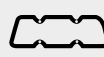
TD1708

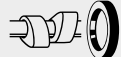
1285

							
B x C x D	OE	MAT.				E x F x G	
<b>V91292</b> 	7 301 820	 MB cr	30°	Y	H	<b>VAG92193</b> 	
40.80 x 8.00 x 120.70						56.00 x 8.04 x 13.05	
<b>V91293</b> 	7 301 821	 MD	45°			<b>VAG92373</b> 	
34.50 x 8.00 x 122.00						56.00 x 8.03 x 13.04	
<b>V91294</b> 	7 302 157	 MF cr	45°		H	<b>VAG92444</b> 	
34.50 x 8.00 x 122.00						56.00 x 8.00 x 13.04	
						<b>VAG92194</b> 	
						60.00 x 8.04 x 13.05	
						<b>VAG92369</b> 	
						60.00 x 8.00 x 13.07	
						<b>VAG92445</b> 	
						60.00 x 8.00 x 13.04	

							
AY591 Fibre Composite, 1.400mm	DS381 ▲			JC054 	JN594		
AB5111 Fibre Composite, 1500mm				JC055 			
							
AB5111	AY591						

## 643

 93.00

**Diesel**



8140.27R.2700

4 Cyl.

18:1











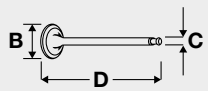
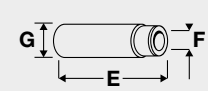











2499cc











67-70kW (92-95)PS



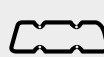

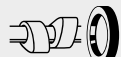



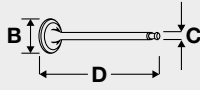

Turbocharged



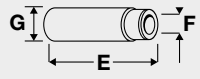
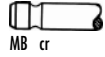

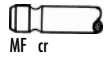





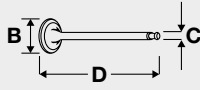

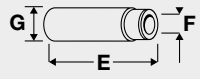
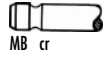

TD20420

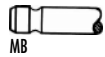

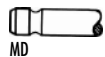

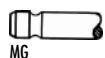

1286

							
B x C x D	OE	MAT.				E x F x G	
<b>V91292</b> 	7 301 820	 MB cr	30°	Y	H	<b>VAG92193</b> 	
40.80 x 8.00 x 120.70						56.00 x 8.04 x 13.05	
<b>V91293</b> 	7 301 821	 MD	45°			<b>VAG92373</b> 	
34.50 x 8.00 x 122.00						56.00 x 8.03 x 13.04	
<b>V91294</b> 	7 302 157	 MF cr	45°		H	<b>VAG92444</b> 	
34.50 x 8.00 x 122.00						56.00 x 8.00 x 13.04	
						<b>VAG92194</b> 	
						60.00 x 8.04 x 13.05	
						<b>VAG92369</b> 	
						60.00 x 8.00 x 13.07	
						<b>VAG92445</b> 	
						60.00 x 8.00 x 13.04	

							
AY591 Fibre Composite, 1.400mm	DS381 ▲			JC054 	JN594		
				JC055 			
							
AY591							

<b>644</b>  <b>93.00</b>		<b>Diesel</b>					
8140.27R.2700, 8140.27S.2700 4 Cyl.		18:1	2499cc	Turbocharged		FM9102	1257
							
B x C x D	OE	MAT.				E x F x G	
<b>V91292</b> ■ 40.80 x 8.00 x 120.70	7 301 820	 MB cr	30°	Y	H	 VAG92373 ■ 56.00 x 8.03 x 13.04	
<b>V91294</b> ■ 34.50 x 8.00 x 122.00	7 302 157	 MF cr	45°		H	 VAG92444 ■ 56.00 x 8.00 x 13.04	
						 VAG92369 ■ 60.00 x 8.00 x 13.07	
						 VAG92445 ■ 60.00 x 8.00 x 13.04	

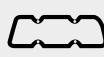
<b>645</b>  <b>93.00</b>		<b>Diesel</b>					
8140.27R.2782		4 Cyl.	18:1	2499cc	70kW (96)PS	Turbocharged	TD1710 1287
							
B x C x D	OE	MAT.				E x F x G	
<b>V91292</b> ■ 40.80 x 8.00 x 120.70	7 301 820	 MB cr	30°	Y	H	 VAG92193 ■ 56.00 x 8.04 x 13.05	
<b>V91399</b> ■ 41.00 x 8.00 x 122.00	4 813 760	 MB	30°		H	 VAG92373 ■ 56.00 x 8.03 x 13.04	
<b>V91293</b> ■ 34.50 x 8.00 x 122.00	7 301 821	 MD	45°			 VAG92444 ■ 56.00 x 8.00 x 13.04	
<b>V91400</b> ■ 34.50 x 8.00 x 122.00	7 303 309	 MG	45°		H	 VAG92194 ■ 60.00 x 8.04 x 13.05	
						 VAG92369 ■ 60.00 x 8.00 x 13.07	
						 VAG92445 ■ 60.00 x 8.00 x 13.04	

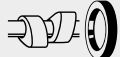
							
AY591 Fibre Composite, 1.400mm	DS381 ▲			JC054 ■ JC055 ■	JN594		NP068 55.00x70.00x8.00mm FPM



AB5111



AY591

## 646

93.00

**Diesel**



8140.27R.2786

4 Cyl.

18:1

2499cc

67-70kW (91-95)PS

Turbocharged

TD27394

1277

B x C x D	OE	MAT.				E x F x G
<b>V91292</b> ■	7 301 820		30°	Y	H	<b>VAG92193</b> ■
40.80 x 8.00 x 120.70		MB cr				56.00 x 8.04 x 13.05
<b>V91399</b> ■	4 813 760		30°		H	<b>VAG92373</b> ■
41.00 x 8.00 x 122.00		MB				56.00 x 8.03 x 13.04
<b>V91293</b> ■	7 301 821		45°			<b>VAG92444</b> ■
34.50 x 8.00 x 122.00		MD				56.00 x 8.00 x 13.04
<b>V91400</b> ■	7 303 309		45°		H	<b>VAG92194</b> ■
34.50 x 8.00 x 122.00		MG				60.00 x 8.04 x 13.05
						<b>VAG92369</b> ■
						60.00 x 8.00 x 13.07
						<b>VAG92445</b> ■
						60.00 x 8.00 x 13.04

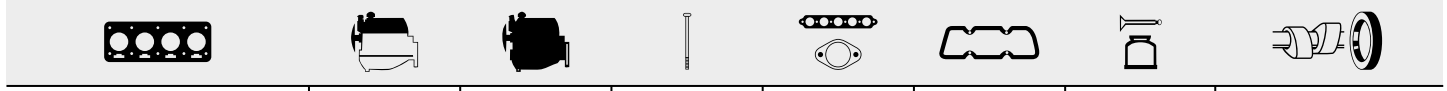

<b>AB5101</b> Fibre Composite, 1200mm						<b>NPO68</b> 55.00x70.00x8.00mm FPM

AB5101

## 647

93.00

**Diesel**



8140.27S.2700

4 Cyl.

18:1

2499cc

76kW (103)PS

Turbocharged

TD20421

1288

B x C x D	OE	MAT.				E x F x G
<b>V91292</b> ■	7 301 820		30°	Y	H	<b>VAG92373</b> ■
40.80 x 8.00 x 120.70		MB cr				56.00 x 8.03 x 13.04
<b>V91294</b> ■	7 302 157		45°		H	<b>VAG92444</b> ■
34.50 x 8.00 x 122.00		MF cr				56.00 x 8.00 x 13.04
						<b>VAG92369</b> ■
						60.00 x 8.00 x 13.07
						<b>VAG92445</b> ■
						60.00 x 8.00 x 13.04

<b>AY581</b> Fibre Composite, 1.300mm	<b>DS381</b> ▲		<b>FB5100</b> ▲ [1]	<b>JC054</b> ■		<b>NPO67</b> ■
<b>AY591</b> Fibre Composite, 1.400mm				<b>JC055</b> ■		50.00x70.00x10.00mm FPM

**AY581** [1] Without crankshaft seal      **AY591** [1] sans bague d'étanchéité - vilebrequin      [1] senza paraolio-albero a gomiti      [1] sin cigüeñal retén

<b>648</b>	<b>93.00</b>	<b>Diesel</b>				
<b>8140.275.2760</b>	4 Cyl.	18:1	2499cc	<b>76kW (103)PS</b>	<b>Turbocharged</b>	<b>TD27405 1277</b>
<b>8140.275.3770</b>	4 Cyl.	18.5:1	2499cc	<b>77kW (104)PS</b>	<b>Turbocharged</b>	<b>TD27422 1277</b>

B x C x D	OE	MAT.				E x F x G
<b>V91292</b>	7 301 820		30°	Y	H	<b>VAG92193</b>
40.80 x 8.00 x 120.70						56.00 x 8.04 x 13.05
<b>V91939</b>	98 468 338		30°		H	<b>VAG92373</b>
43.50 x 8.00 x 122.00						56.00 x 8.03 x 13.04
<b>V91293</b>	7 301 821		45°			<b>VAG92444</b>
34.50 x 8.00 x 122.00						56.00 x 8.00 x 13.04
<b>V91940</b>	98 418 161		45°		H	<b>VAG92194</b>
36.70 x 8.00 x 122.00						60.00 x 8.04 x 13.05
<b>V91994</b>	99 432 837		45°			<b>VAG92369</b>
35.80 x 8.00 x 121.90						60.00 x 8.00 x 13.07
						<b>VAG92445</b>
						60.00 x 8.00 x 13.04

<b>AB5101</b> Fibre Composite, 1200mm						<b>NPO68</b> 55.00x70.00x8.00mm FPM



AB5101

<b>649</b>	<b>93.00</b>	<b>Diesel</b>				
<b>8140.275.2761</b>	4 Cyl.	18:1	2499cc	<b>76kW (103)PS</b>	<b>Turbocharged</b>	<b>TD27406 1277</b>
<b>8140.275.3811</b>	4 Cyl.	18.5:1	2499cc	<b>77kW (104)PS</b>	<b>Turbocharged</b>	<b>TD27426 1277</b>

B x C x D	OE	MAT.				E x F x G
<b>V91292</b>	7 301 820		30°	Y	H	<b>VAG92193</b>
40.80 x 8.00 x 120.70						56.00 x 8.04 x 13.05
<b>V91939</b>	98 468 338		30°		H	<b>VAG92373</b>
43.50 x 8.00 x 122.00						56.00 x 8.03 x 13.04
<b>V91293</b>	7 301 821		45°			<b>VAG92444</b>
34.50 x 8.00 x 122.00						56.00 x 8.00 x 13.04
<b>V91940</b>	98 418 161		45°		H	<b>VAG92194</b>
36.70 x 8.00 x 122.00						60.00 x 8.04 x 13.05
<b>V91994</b>	99 432 837		45°			<b>VAG92369</b>
35.80 x 8.00 x 121.90						60.00 x 8.00 x 13.07
						<b>VAG92445</b>
						60.00 x 8.00 x 13.04

<b>AY591</b> Fibre Composite, 1.400mm						<b>NPO68</b> 55.00x70.00x8.00mm FPM



AY591

## 650

## 93.00

### Diesel



8140.275.2801

4 Cyl.

18:1

2499cc

76kW (103)PS

Turbocharged

TD20419

1289

B x C x D	OE	MAT.	Angle	Y	H	E x F x G	
<b>V91292</b> ■	7 301 820		30°	Y	H	<b>VAG92193</b> ■	
40.80 x 8.00 x 120.70						56.00 x 8.04 x 13.05	
<b>V91293</b> ■	7 301 821		45°			<b>VAG92373</b> ■	
34.50 x 8.00 x 122.00						56.00 x 8.03 x 13.04	
<b>V91294</b> ■	7 302 157		45°		H	<b>VAG92444</b> ■	
34.50 x 8.00 x 122.00						56.00 x 8.00 x 13.04	
						<b>VAG92194</b> ■	
						60.00 x 8.04 x 13.05	
						<b>VAG92369</b> ■	
						60.00 x 8.00 x 13.07	
						<b>VAG92445</b> ■	
						60.00 x 8.00 x 13.04	

<b>AY581</b> Fibre Composite, 1.300mm	<b>DR073</b> ▲	<b>FB5102</b> ▲ [1]	<b>HBS011</b> ⊕	<b>JC054</b> ■	<b>JN594</b>		<b>NP068</b> ■
<b>AY591</b> Fibre Composite, 1.400mm	<b>DS381</b> ▲		M12x1.25x119.00mm (x12)	<b>JC055</b> ■			55.00x70.00x8.00mm FPM
<b>AB5101</b> Fibre Composite, 1200mm							<b>NP067</b> ■
<b>AB5111</b> Fibre Composite, 1500mm							50.00x70.00x10.00mm FPM
<b>AB5101</b>	<b>AB5111</b>	<b>AY581</b>	<b>AY591</b>				
[1] Without crankshaft seal		[1] sans bague d'étanchéité - vilebrequin		[1] senza paraolio-albero a gomiti			[1] sin cigüeñal retén

## 651

## 93.00

### Diesel



8140.275.2885

4 Cyl.

18:1

2499cc

76kW (103)PS

Turbocharged

TD20422

1286

B x C x D	OE	MAT.	Angle	Y	H	E x F x G	
<b>V91292</b> ■	7 301 820		30°	Y	H	<b>VAG92193</b> ■	
40.80 x 8.00 x 120.70						56.00 x 8.04 x 13.05	
<b>V91293</b> ■	7 301 821		45°			<b>VAG92373</b> ■	
34.50 x 8.00 x 122.00						56.00 x 8.03 x 13.04	
<b>V91294</b> ■	7 302 157		45°		H	<b>VAG92444</b> ■	
34.50 x 8.00 x 122.00						56.00 x 8.00 x 13.04	
						<b>VAG92194</b> ■	
						60.00 x 8.04 x 13.05	
						<b>VAG92369</b> ■	
						60.00 x 8.00 x 13.07	
						<b>VAG92445</b> ■	
						60.00 x 8.00 x 13.04	

<b>AY591</b> Fibre Composite, 1.400mm	<b>DS381</b> ▲			<b>JC054</b> ■	<b>JN594</b>		<b>NP068</b>
				<b>JC055</b> ■			55.00x70.00x8.00mm FPM
<b>AY591</b>							

## 652

## 93.00

## Diesel



8140.47.2700 Euro 1

4 Cyl.

18:1

2499cc

85kW (116)PS

Turbocharged

TD1711

1291

<b>TB250</b> 153x30 Eng. → 1307400					

 B x C x D	OE	MAT.	 30° Y H 45° 45° H	 E x F x G
<b>V91292</b> ■ 40.80 x 8.00 x 120.70	7 301 820	 MB cr	30° Y H	<b>VAG92193</b> ■ 56.00 x 8.04 x 13.05
<b>V91293</b> ■ 34.50 x 8.00 x 122.00	7 301 821	 MD	45°	<b>VAG92373</b> ■ 56.00 x 8.03 x 13.04
<b>V91294</b> ■ 34.50 x 8.00 x 122.00	7 302 157	 MF cr	45° H	<b>VAG92444</b> ■ 56.00 x 8.00 x 13.04
				<b>VAG92194</b> ■ 60.00 x 8.04 x 13.05
				<b>VAG92369</b> ■ 60.00 x 8.00 x 13.07
				<b>VAG92445</b> ■ 60.00 x 8.00 x 13.04

<b>AY581</b> Fibre Composite, 1.300mm <b>AY591</b> Fibre Composite, 1.400mm <b>AB5101</b> Fibre Composite, 1200mm <b>AB5111</b> Fibre Composite, 1500mm	<b>DS381</b> ▲	<b>FB5101</b> ▲ [1]	<b>HBS011</b> ⊕ M12x1.25x119.00mm (x12)	<b>JC054</b> ■ <b>JC055</b> ■	<b>JN594</b>	<b>HR602</b> ■	<b>NP068</b> 55.00x70.00x8.00mm FPM <b>NP067</b> 50.00x70.00x10.00mm FPM

<b>AB5101</b> [1] Without crankshaft seal	<b>AB5111</b>	<b>AY581</b> [1] sans bague d'étanchéité - vilebrequin	<b>AY591</b> [1] senza paraolio-albero a gomiti			<b>HR602</b> ■ [1] sin cigüeñal retén

## 653

93.00

Diesel



8140.47.2721 Euro 1

4 Cyl.

18:1

2499cc

85kW (116)PS

Turbocharged

TD1713

1293

B x C x D	OE	MAT.				E x F x G	
<b>V91292</b> ■	7 301 820		30°	Y	H	<b>VAG92193</b> ■	
40.80 x 8.00 x 120.70		MB cr				56.00 x 8.04 x 13.05	
<b>V91293</b> ■	7 301 821		45°			<b>VAG92373</b> ■	
34.50 x 8.00 x 122.00		MD				56.00 x 8.03 x 13.04	
<b>V91294</b> ■	7 302 157		45°		H	<b>VAG92444</b> ■	
34.50 x 8.00 x 122.00		MF cr				56.00 x 8.00 x 13.04	
						<b>VAG92194</b> ■	
						60.00 x 8.04 x 13.05	
						<b>VAG92369</b> ■	
						60.00 x 8.00 x 13.07	
						<b>VAG92445</b> ■	
						60.00 x 8.00 x 13.04	

<b>AY581</b> Fibre Composite, 1.300mm	<b>DS381</b> ▲	<b>FB5101</b> ▲ [1]	<b>HBS011</b> ⊕ M12x1.25x119.00mm (x12)	<b>JC054</b> ■ <b>JC055</b> ■	<b>JN594</b>	<b>HR602</b> ■	<b>NP068</b> 55.00x70.00x8.00mm FPM
<b>AY591</b> Fibre Composite, 1.400mm							
<b>AB5101</b> Fibre Composite, 1200mm							
<b>AB5111</b> Fibre Composite, 1500mm							
<b>AB5101</b>	<b>AB5111</b>	<b>AY581</b>	<b>AY591</b>				
[1] Without crankshaft seal		[1] sans bague d'étanchéité - vilebrequin		[1] senza paraolio-albero a gomiti			[1] sin cigüeñal retén

## 654

93.00

Diesel



8140.47.2785 Euro 1

4 Cyl.

18:1

2499cc

85kW (116)PS

Turbocharged

TD1715

1294

B x C x D	OE	MAT.				E x F x G	
<b>V91292</b> ■	7 301 820		30°	Y	H	<b>VAG92193</b> ■	
40.80 x 8.00 x 120.70		MB cr				56.00 x 8.04 x 13.05	
<b>V91293</b> ■	7 301 821		45°			<b>VAG92373</b> ■	
34.50 x 8.00 x 122.00		MD				56.00 x 8.03 x 13.04	
<b>V91294</b> ■	7 302 157		45°		H	<b>VAG92444</b> ■	
34.50 x 8.00 x 122.00		MF cr				56.00 x 8.00 x 13.04	
						<b>VAG92194</b> ■	
						60.00 x 8.04 x 13.05	
						<b>VAG92369</b> ■	
						60.00 x 8.00 x 13.07	
						<b>VAG92445</b> ■	
						60.00 x 8.00 x 13.04	

<b>AY591</b> Fibre Composite, 1.400mm					<b>JC054</b> ■ <b>JC055</b> ■	<b>JN594</b>	
<b>AB5111</b> Fibre Composite, 1500mm							
<b>AB5111</b>	<b>AY591</b>						



<b>655</b>	<b>93.00</b>	<b>Diesel</b>					
8140.47.3700	4 Cyl.	18.5:1	2499cc	85kW (116)PS	Turbo Intercooled	TD6809	1299

B x C x D	OE	MAT.				E x F x G	
<b>V91292</b>	7 301 820	 MB cr	30°	Y	H	<b>VAG92193</b>	
40.80 x 8.00 x 120.70						56.00 x 8.04 x 13.05	
<b>V91293</b>	7 301 821	 MD	45°			<b>VAG92373</b>	
34.50 x 8.00 x 122.00						56.00 x 8.03 x 13.04	
<b>V91294</b>	7 302 157	 MF cr	45°		H	<b>VAG92444</b>	
34.50 x 8.00 x 122.00						56.00 x 8.00 x 13.04	
						<b>VAG92194</b>	
						60.00 x 8.04 x 13.05	
						<b>VAG92369</b>	
						60.00 x 8.00 x 13.07	
						<b>VAG92445</b>	
						60.00 x 8.00 x 13.04	

AB5111 Fibre Composite, 1500mm	DS381			JC054			NP068 55.00x70.00x8.00mm FPM



AB5111

<b>656</b>	<b>93.00</b>	<b>Diesel</b>					
8140.47.3700 Euro I	4 Cyl.	18.5:1	2499cc	85kW (116)PS	Turbo Intercooled	TD20477	1295

B x C x D	OE	MAT.				E x F x G	
<b>V91292</b>	7 301 820	 MB cr	30°	Y	H	<b>VAG92193</b>	
40.80 x 8.00 x 120.70						56.00 x 8.04 x 13.05	
<b>V91293</b>	7 301 821	 MD	45°			<b>VAG92373</b>	
34.50 x 8.00 x 122.00						56.00 x 8.03 x 13.04	
<b>V91294</b>	7 302 157	 MF cr	45°		H	<b>VAG92444</b>	
34.50 x 8.00 x 122.00						56.00 x 8.00 x 13.04	
						<b>VAG92194</b>	
						60.00 x 8.04 x 13.05	
						<b>VAG92369</b>	
						60.00 x 8.00 x 13.07	
						<b>VAG92445</b>	
						60.00 x 8.00 x 13.04	

AY591 Fibre Composite, 1.400mm	DS381			JC055	JN594		



AY591

## 657

 93.00

**Diesel**



8140.47.3711 Euro 1

4 Cyl.

18.5:1











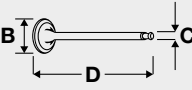
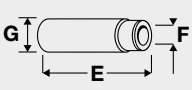

2499cc







85kW (116)PS

Turbo Intercooled

TD26005

1296

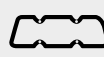
								
B x C x D	OE	MAT.				E x F x G		
<b>V91292</b> ■	7 301 820		30°	Y	H	<b>VAG92193</b> ■		
40.80 x 8.00 x 120.70		MB cr				56.00 x 8.04 x 13.05		
<b>V91939</b> ■	98 468 338		30°		H	<b>VAG92373</b> ■		
43.50 x 8.00 x 122.00		MB cr				56.00 x 8.03 x 13.04		
<b>V91293</b> ■	7 301 821		45°			<b>VAG92444</b> ■		
34.50 x 8.00 x 122.00		MD				56.00 x 8.00 x 13.04		
<b>V91940</b> ■	98 418 161		45°		H	<b>VAG92194</b> ■		
36.70 x 8.00 x 122.00		MG cr				60.00 x 8.04 x 13.05		
<b>V91994</b> ■	99 432 837		45°			<b>VAG92369</b> ■		
35.80 x 8.00 x 121.90		MD cr				60.00 x 8.00 x 13.07		
						<b>VAG92445</b> ■		
						60.00 x 8.00 x 13.04		

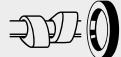
							
							<b>NP068</b> 55.00x70.00x8.00mm FPM

## 658

 93.00

**Diesel**



8140.47R

4 Cyl.

18:1









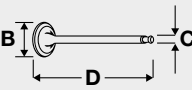
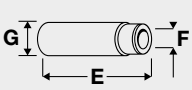

2499cc





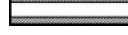

80kW (109)PS

Turbocharged

TD7234

1297

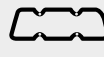
								
B x C x D	OE	MAT.				E x F x G		
<b>V91292</b> ■	7 301 820		30°	Y	H	<b>VAG92193</b> ■		
40.80 x 8.00 x 120.70		MB cr				56.00 x 8.04 x 13.05		
<b>V91293</b> ■	7 301 821		45°			<b>VAG92373</b> ■		
34.50 x 8.00 x 122.00		MD				56.00 x 8.03 x 13.04		
<b>V91294</b> ■	7 302 157		45°		H	<b>VAG92444</b> ■		
34.50 x 8.00 x 122.00		MF cr				56.00 x 8.00 x 13.04		
						<b>VAG92194</b> ■		
						60.00 x 8.04 x 13.05		
						<b>VAG92369</b> ■		
						60.00 x 8.00 x 13.07		
						<b>VAG92445</b> ■		
						60.00 x 8.00 x 13.04		

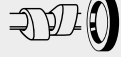
							
<b>AY581</b> Fibre Composite, 1.300mm	<b>DS381</b> ▲	<b>FB5101</b> ▲ [1]	<b>HBS011</b> ⊕ M12x1.25x119.00mm (x12)	<b>JC054</b> ■ <b>JC055</b> ■	<b>JN594</b>	<b>HR602</b> ■	<b>NP068</b> 55.00x70.00x8.00mm FPM <b>NP067</b> 50.00x70.00x10.00mm FPM



**AY5101**  
[1] Without crankshaft seal



**AB5111**



**AY581**  
[1] sans bague d'étanchéité - vilebrequin



**AY591**  
[1] senza paraolio-albero a gomiti

[1] sin cigüeñal retén

## 659

## 93.00

## Diesel



8140.47R.2210

4 Cyl.

18.5:1

2499cc

80kW (110)PS

Turbo Intercooled

TD6811

1290

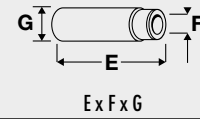
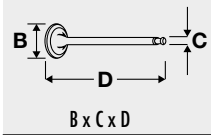

B x C x D	OE	MAT.	30°	Y	H	E x F x G
<b>V91292</b> ■	7 301 820		30°	Y	H	<b>VAG92193</b> ■
40.80 x 8.00 x 120.70		MB cr				56.00 x 8.04 x 13.05
<b>V91939</b> ■	98 468 338		30°		H	<b>VAG92373</b> ■
43.50 x 8.00 x 122.00		MB cr				56.00 x 8.03 x 13.04
<b>V91293</b> ■	7 301 821		45°			<b>VAG92444</b> ■
34.50 x 8.00 x 122.00		MD				56.00 x 8.00 x 13.04
<b>V91940</b> ■	98 418 161		45°		H	<b>VAG92194</b> ■
36.70 x 8.00 x 122.00		MG cr				60.00 x 8.04 x 13.05
<b>V91994</b> ■	99 432 837		45°			<b>VAG92369</b> ■
35.80 x 8.00 x 121.90		MD cr				60.00 x 8.00 x 13.07
						<b>VAG92445</b> ■
						60.00 x 8.00 x 13.04

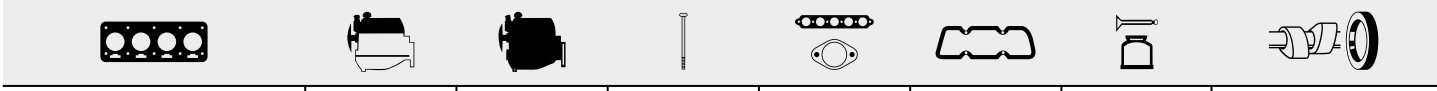

AB5111 Fibre Composite, 1500mm



AB5111

JC054 ■



8140.47R.2790

4 Cyl.

18.5:1

2499cc

76-80kW (103-109)PS

Turbo Intercooled

TD1716

1298



**TB250**  
153x30  
Eng. → 1307400

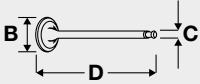

B x C x D

OE



MAT.



30°

Y

H

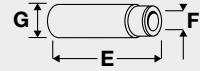

E x F x G

**V91292** ■  
40.80 x 8.00 x 120.70

7 301 820

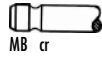

MB cr

45°

Y

H

**V91293** ■  
34.50 x 8.00 x 122.00

7 301 821

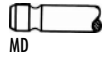

MD

**V91294** ■  
34.50 x 8.00 x 122.00

7 302 157

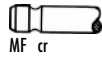

MF cr

45°

H

**VAG92193** ■  
56.00 x 8.04 x 13.05



**VAG92373** ■  
56.00 x 8.03 x 13.04



**VAG92444** ■  
56.00 x 8.00 x 13.04



**VAG92194** ■  
60.00 x 8.04 x 13.05



**VAG92369** ■  
60.00 x 8.00 x 13.07



**VAG92445** ■  
60.00 x 8.00 x 13.04

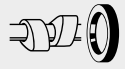
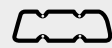

**AY581** Fibre Composite, 1.300mm  
**AY591** Fibre Composite, 1.400mm  
**AB5101** Fibre Composite, 1200mm  
**AB5111** Fibre Composite, 1500mm

**DS381** ▲

**FB5101** ▲ [1]

**HBS011** ①  
M12x1.25x119.00mm (x12)

**JC054** ■  
**JC055** ■  
⊙ JF123

**JN594**

**HR602** ■

**NP068**  
55.00x70.00x8.00mm FPM

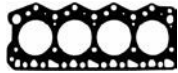

**AB5101**

**AB5111**

**AY581**

**AY591**

[1] Without crankshaft seal

[1] sans bague d'étanchéité - vilebrequin

[1] senza paraolio-albero a gomiti

[1] sin cigüeñal retén

<b>661</b>	<b>93.00</b>	<b>Diesel</b>								
8140.475 Euro 1	4 Cyl.	18.5:1	2499cc	85kW (116)PS	Turbo Intercooled	TD20453	1299			

B x C x D	OE	MAT.				E x F x G	
<b>V91292</b>	7 301 820		30°	Y	H	<b>VAG92193</b>	
40.80 x 8.00 x 120.70						56.00 x 8.04 x 13.05	
<b>V91293</b>	7 301 821		45°			<b>VAG92373</b>	
34.50 x 8.00 x 122.00						56.00 x 8.03 x 13.04	
<b>V91294</b>	7 302 157		45°		H	<b>VAG92444</b>	
34.50 x 8.00 x 122.00						56.00 x 8.00 x 13.04	
						<b>VAG92194</b>	
						60.00 x 8.04 x 13.05	
						<b>VAG92369</b>	
						60.00 x 8.00 x 13.07	
						<b>VAG92445</b>	
						60.00 x 8.00 x 13.04	

AY591 Fibre Composite, 1.400mm					JC054					
					JC055					



AY591

<b>662</b>	<b>93.00</b>	<b>Diesel</b>								
8140.67F.3700 Euro 2	4 Cyl.	21:1	2499cc	60-63kW (82-86)PS		TD20428	1301			

B x C x D	OE	MAT.				E x F x G	
<b>V91939</b>	98 468 338		30°		H	<b>VAG92193</b>	
43.50 x 8.00 x 122.00						56.00 x 8.04 x 13.05	
<b>V91940</b>	98 418 161		45°		H	<b>VAG92373</b>	
36.70 x 8.00 x 122.00						56.00 x 8.03 x 13.04	
						<b>VAG92444</b>	
						56.00 x 8.00 x 13.04	
						<b>VAG92194</b>	
						60.00 x 8.04 x 13.05	
						<b>VAG92369</b>	
						60.00 x 8.00 x 13.07	
						<b>VAG92445</b>	
						60.00 x 8.00 x 13.04	

AY300 Fibre Composite, 1.700mm					JC054					
					JC055					



AY300

# FIAT GROUP

**663**

 **93.00**

**Diesel**



8140.67F. Euro 2

4 Cyl.

21:1

2499cc

60kW (82)PS

**TD7226**

**1302**



**KIT**



**TB250**  
153x30  
Eng. → 1307400

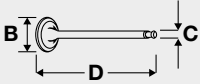

B x C x D

OE



MAT.



30°

H

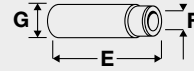

E x F x G

**V91939** ■  
43.50 x 8.00 x 122.00

98 468 338

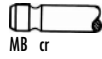

MB cr

45°

H

**VAG92193** ■  
56.00 x 8.04 x 13.05



**V91940** ■  
36.70 x 8.00 x 122.00

98 418 161

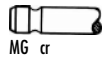

MG cr

**VAG92373** ■  
56.00 x 8.03 x 13.04



**VAG92444** ■  
56.00 x 8.00 x 13.04



**VAG92194** ■  
60.00 x 8.04 x 13.05



**VAG92369** ■  
60.00 x 8.00 x 13.07



**VAG92445** ■  
60.00 x 8.00 x 13.04

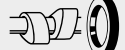
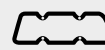

**AY581** Fibre Composite, 1.300mm  
**AY591** Fibre Composite, 1.400mm  
**AY300** Fibre Composite, 1.700mm  
**AB5101** Fibre Composite, 1200mm  
**AB5111** Fibre Composite, 1500mm

**DS381** ▲

**HBS011** ①  
M12x1.25x119.00mm (x12)

**JC054** ■  
**JC055** ■

**JN594**

**HR602** ■

**NP068**  
55.00x70.00x8.00mm FPM

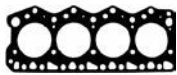

**AB5101**

**AB5111**

**AY300**

**AY581**

**AY591**

**664**

 **93.00**

**Diesel**



8140.97.2781

4 Cyl.

18:1

2499cc

68kW (92)PS

Turbo Intercooled

**TD1717**

**1303**

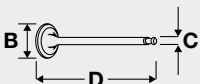

B x C x D

OE



MAT.



30°

Y

H

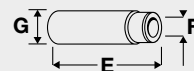

E x F x G

**V91292** ■  
40.80 x 8.00 x 120.70

7 301 820

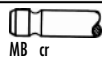

MB cr

45°

H

**VAG92193** ■  
56.00 x 8.04 x 13.05

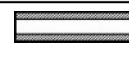

**V91293** ■  
34.50 x 8.00 x 122.00

7 301 821

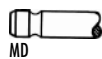

MD

**VAG92373** ■  
56.00 x 8.03 x 13.04



**V91294** ■  
34.50 x 8.00 x 122.00

7 302 157

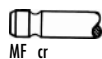

MF cr

**VAG92444** ■  
56.00 x 8.00 x 13.04



**VAG92194** ■  
60.00 x 8.04 x 13.05



**VAG92369** ■  
60.00 x 8.00 x 13.07



**VAG92445** ■  
60.00 x 8.00 x 13.04

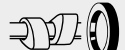

**JC054** ■  
**JC055** ■

**JN594**

<b>665</b>	<b>93.00</b>	<b>Diesel</b>				
8144.67.220	4 Cyl.	22:1	2499cc	55kW (75)PS	TD6797	<b>1306</b>

B x C x D	OE	MAT.	Angle	Y	H	E x F x G
<b>V91292</b> ■	7 301 820		30°	Y	H	<b>VAG92193</b> ■ 56.00 x 8.04 x 13.05
40.80 x 8.00 x 120.70						<b>VAG92373</b> ■ 56.00 x 8.03 x 13.04
<b>V91293</b> ■	7 301 821		45°			<b>VAG92444</b> ■ 56.00 x 8.00 x 13.04
34.50 x 8.00 x 122.00						<b>VAG92194</b> ■ 60.00 x 8.04 x 13.05
<b>V91294</b> ■	7 302 157		45°		H	<b>VAG92369</b> ■ 60.00 x 8.00 x 13.07
34.50 x 8.00 x 122.00						<b>VAG92445</b> ■ 60.00 x 8.00 x 13.04

				JC054 ■			NP068 55.00x70.00x8.00mm FPM

<b>666</b>	<b>93.00</b>	<b>Diesel</b>				
8144.67.220	4 Cyl.	22:1	2499cc	55kW (75)PS	TD147	<b>1305</b>

B x C x D	OE	MAT.	Angle	Y	H	E x F x G
<b>V91292</b> ■	7 301 820		30°	Y	H	<b>VAG92193</b> ■ 56.00 x 8.04 x 13.05
40.80 x 8.00 x 120.70						<b>VAG92373</b> ■ 56.00 x 8.03 x 13.04
<b>V91293</b> ■	7 301 821		45°			<b>VAG92444</b> ■ 56.00 x 8.00 x 13.04
34.50 x 8.00 x 122.00						<b>VAG92194</b> ■ 60.00 x 8.04 x 13.05
<b>V91294</b> ■	7 302 157		45°		H	<b>VAG92369</b> ■ 60.00 x 8.00 x 13.07
34.50 x 8.00 x 122.00						<b>VAG92445</b> ■ 60.00 x 8.00 x 13.04

AY290 Fibre Composite, 1.600mm	DE588 ▲	FY291 ▲ [1]	HBS011 ① M12x1.25x119.00mm (x12)	JC054 ■ (x4)	JN462	HR602 ■	NP068 55.00x70.00x8.00mm FPM
AY300 Fibre Composite, 1.700mm				JC055 ■ (x4)	JN594		
AY310 Fibre Composite, 1.800mm					Eng.574799→		



AY290, AY300, AY310  
[1] Without crankshaft seal

[1] sans bague d'étanchéité - vilebrequin

[1] senza paraolio-albero a gomiti

[1] sin cigüeñal retén



8144.97      4 Cyl.      22:1      2499cc      85kW (115)PS      Turbocharged      TD4601      1308



TB348  
99x19

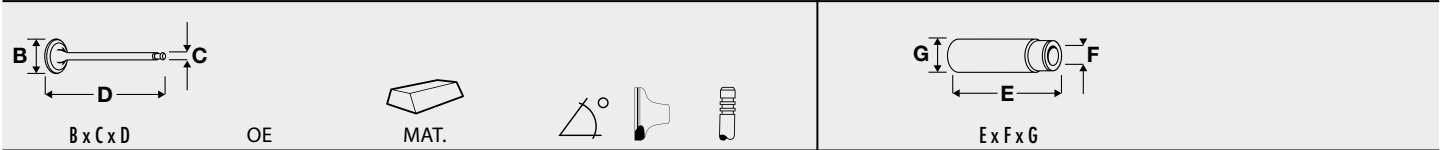

B x C x D	OE	MAT.	Angle	Y	H	E x F x G
<b>V91292</b> ■ 40.80 x 8.00 x 120.70	7 301 820	 MB cr	30°	Y	H	 <b>VAG92193</b> ■ 56.00 x 8.04 x 13.05
<b>V91293</b> ■ 34.50 x 8.00 x 122.00	7 301 821	 MD	45°			 <b>VAG92373</b> ■ 56.00 x 8.03 x 13.04
<b>V91294</b> ■ 34.50 x 8.00 x 122.00	7 302 157	 MF cr	45°		H	 <b>VAG92444</b> ■ 56.00 x 8.00 x 13.04
						 <b>VAG92194</b> ■ 60.00 x 8.04 x 13.05
						 <b>VAG92369</b> ■ 60.00 x 8.00 x 13.07
						 <b>VAG92445</b> ■ 60.00 x 8.00 x 13.04

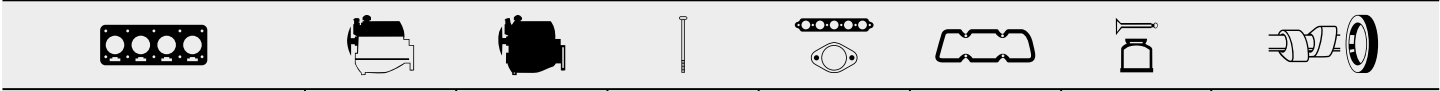

<b>AY290</b> Fibre Composite, 1.600mm <b>AY300</b> Fibre Composite, 1.700mm <b>AY310</b> Fibre Composite, 1.800mm	<b>DP273</b> ▲ <b>DT752</b> ▲		<b>HBS011</b> ① M12x1.25x119.00mm (x12)	<b>JC054</b> ■	<b>JN585</b>	<b>NF841</b> 35.00x50.00x8.00mm FPM <b>NPO68</b> 55.00x70.00x8.00mm FPM
---	----------------------------------	--	--	----------------	--------------	--



AY290, AY300, AY310



<b>668</b>	<b>93.00</b>	<b>Diesel</b>				
8144.97	4 Cyl.	2499cc	85kW (115)PS	Turbo Intercooled	TD1061	<b>1307</b>
<b>TB348</b> 99x19 →01/93		<b>CAM681</b>				

	OE	MAT.				
B x C x D						E x F x G
<b>V91292</b> ■ 40.80 x 8.00 x 120.70	7 301 820	 MB cr	30°	Y	H	 <b>VAG92193</b> ■ 56.00 x 8.04 x 13.05
<b>V91293</b> ■ 34.50 x 8.00 x 122.00	7 301 821	 MD	45°			 <b>VAG92373</b> ■ 56.00 x 8.03 x 13.04
<b>V91294</b> ■ 34.50 x 8.00 x 122.00	7 302 157	 MF cr	45°		H	 <b>VAG92444</b> ■ 56.00 x 8.00 x 13.04
						 <b>VAG92194</b> ■ 60.00 x 8.04 x 13.05
						 <b>VAG92369</b> ■ 60.00 x 8.00 x 13.07
						 <b>VAG92445</b> ■ 60.00 x 8.00 x 13.04

AY290 Fibre Composite, 1.600mm AY300 Fibre Composite, 1.700mm AY310 Fibre Composite, 1.800mm	DP273 ▲	HBS011 ◊ M12x1.25x119.00mm (x12)	JC054 ■ JC055 ■	JN585	NP068 55.00x70.00x8.00mm FPM

AY290, AY300, AY310

<b>669</b>	<b>93.00</b>	<b>Diesel</b>					
8144.97.2200	4 Cyl.	22:1	2499cc	85-87kW (116-118)PS	Turbo Intercooled	TD19036	<b>1309</b>
						<b>NF841</b> 35.00x50.00x8.00mm FPM	

# FIAT GROUP

<b>670</b>	<b>93.00</b>	<b>Diesel</b>					
8144.97.2400	4 Cyl.	21:1	2499cc	83-87kW (113-118)PS	Turbo Intercooled	TD22316	<b>1307</b>
<b>TB348</b> 99x19 →01/93							

AY290 Fibre Composite, 1.600mm AY300 Fibre Composite, 1.700mm AY310 Fibre Composite, 1.800mm	DP273 ▲	HBS011 Ⓢ M12x1.25x119.00mm (x12)	JC054 ■ JC055 ■	JN585	NPO68 55.00x70.00x8.00mm FPM



AY290, AY300, AY310



<b>671</b>	<b>93.00</b>	<b>Diesel</b>				
8140.07.2585 Euro 1	4 Cyl.	18.5:1	2500cc	55kW (75)PS	TD20437	<b>1310</b>







 B x C x D	 E x F x G
<b>V91399 ■</b> 41.00 x 8.00 x 122.00 <b>V91400 ■</b> 34.50 x 8.00 x 122.00	<b>VAG92193 ■</b> 56.00 x 8.04 x 13.05 <b>VAG92373 ■</b> 56.00 x 8.03 x 13.04 <b>VAG92369 ■</b> 60.00 x 8.00 x 13.07 <b>VAG92445 ■</b> 60.00 x 8.00 x 13.04
OE: 4 813 760 MAT: MB, MG Angle: 30°, 45° H: H	

AY591 Fibre Composite, 1.400mm	DS381 ▲	JC054 ■ JC055 ■	JN594











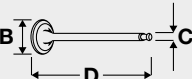



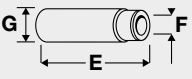











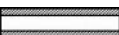



AY591





**672**  **93.00** **Diesel**   
**8140.27** 4 Cyl. 18.5:1 2500cc **70kW (95)PS** **Turbocharged** **TD1047** **1311**



					
<b>TB701</b> 153x30	<b>TBK039</b> Component No: TB701; AE1010GP	<b>CAM681</b> Eng: 1197078→			<b>FOL169 (x8) [6]</b>











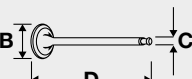



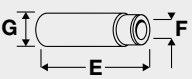

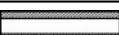
[6] Mechanical [6] Mécanique [6] Meccanico [6] Mecánico





	OE	MAT.				
B x C x D						E x F x G
<b>V91292</b> 	7 301 820		30°	Y	H	<b>VAG92193</b> 
40.80 x 8.00 x 120.70		MB cr				56.00 x 8.04 x 13.05
<b>V91293</b> 	7 301 821		45°			<b>VAG92373</b> 
34.50 x 8.00 x 122.00		MD				56.00 x 8.03 x 13.04
<b>V91294</b> 	7 302 157		45°		H	<b>VAG92444</b> 
34.50 x 8.00 x 122.00		MF cr				56.00 x 8.00 x 13.04
						<b>VAG92194</b> 
						60.00 x 8.04 x 13.05
						<b>VAG92369</b> 
						60.00 x 8.00 x 13.07
						<b>VAG92445</b> 
						60.00 x 8.00 x 13.04

							
<b>AY581</b> Fibre Composite, 1.300mm	<b>DR073</b> ▲	<b>FB5102</b> ▲ [1]	<b>HBS011</b> Ⓢ	<b>JC054</b> 	<b>JN956</b>	<b>HR602</b> 	<b>NP068</b>
<b>AY591</b> Fibre Composite, 1.400mm	<b>DS381</b> ▲		M12x1.25x119.00mm (x12)	<b>JC055</b> 	<b>JN594</b>		55.00x70.00x8.00mm FPM
<b>AB5101</b> Fibre Composite, 1200mm	Eng.1050634→			<b>JF123</b> 	Eng.574799→		
<b>AB5111</b> Fibre Composite, 1500mm							

			
<b>AB5101</b>	<b>AB5111</b>	<b>AY581</b>	<b>AY591</b>
[1] Without crankshaft seal		[1] sans bague d'étanchéité - vilebrequin	[1] senza paraolio-albero a gomiti
			[1] sin cigüeñal retén

**673**  **93.00** **Diesel**   
**8140.27.2100** 4 Cyl. 18.5:1 2500cc **70kW (95)PS** **Turbocharged** **TD6800** **1312**

	OE	MAT.				
B x C x D						E x F x G
<b>V91292</b> 	7 301 820		30°	Y	H	<b>VAG92193</b> 
40.80 x 8.00 x 120.70		MB cr				56.00 x 8.04 x 13.05
<b>V91293</b> 	7 301 821		45°			<b>VAG92373</b> 
34.50 x 8.00 x 122.00		MD				56.00 x 8.03 x 13.04
<b>V91294</b> 	7 302 157		45°		H	<b>VAG92444</b> 
34.50 x 8.00 x 122.00		MF cr				56.00 x 8.00 x 13.04
						<b>VAG92194</b> 
						60.00 x 8.04 x 13.05
						<b>VAG92369</b> 
						60.00 x 8.00 x 13.07
						<b>VAG92445</b> 
						60.00 x 8.00 x 13.04

		
<b>DR073</b> ▲	<b>JC054</b> 	<b>HR599</b> 



8140.47      4 Cyl.      18.5:1      2500cc      80-85kW (109-116)PS      Turbocharged      TD1048      1313

<b>TB701</b> 153x30 →08/98	<b>TBK039</b> →08/98 Component No: TB701; AE1010GP		<b>KIT</b>		

	OE	MAT.				
B x C x D						E x F x G
<b>V91292</b> ■ 40.80 x 8.00 x 120.70	7 301 820	 MB cr	30°	Y	H	 <b>VAG92193</b> ■ 56.00 x 8.04 x 13.05
<b>V91293</b> ■ 34.50 x 8.00 x 122.00	7 301 821	 MD	45°			 <b>VAG92373</b> ■ 56.00 x 8.03 x 13.04
<b>V91294</b> ■ 34.50 x 8.00 x 122.00	7 302 157	 MF cr	45°		H	 <b>VAG92444</b> ■ 56.00 x 8.00 x 13.04
						 <b>VAG92194</b> ■ 60.00 x 8.04 x 13.05
						 <b>VAG92369</b> ■ 60.00 x 8.00 x 13.07
						 <b>VAG92445</b> ■ 60.00 x 8.00 x 13.04

<b>AY581</b> Fibre Composite, 1.300mm <b>AY591</b> Fibre Composite, 1.400mm <b>AB5101</b> Fibre Composite, 1200mm <b>AB5111</b> Fibre Composite, 1500mm	<b>DS381</b> ▲	<b>FB5101</b> ▲ [1]	<b>HBS011</b> ① M12x1.25x119.00mm (x12)	<b>JC054</b> ■ <b>JC055</b> ■	<b>JN594</b> <b>JN956</b>	<b>HR602</b> ■	<b>NP068</b> ■ 55.00x70.00x8.00mm FPM



**AB5101** [1] Without crankshaft seal      **AB5111**      **AY581** [1] sans bague d'étanchéité - vilebrequin      **AY591** [1] senza paraolio-albero a gomiti      [1] sin cigüeñal retén

<b>675</b>	<b>93.00</b>	<b>Diesel</b>	
<b>8140.47R</b>	4 Cyl.	18.5:1	2500cc
			<b>80kW (110)PS</b>
			<b>Turbocharged</b>
			<b>TD1049 1313</b>

<b>TB701</b> 153x30 →08/98	<b>TBK039</b> →08/98 Component No: TB701; AE1010GP		<b>KIT</b>		

 B x C x D	OE	MAT.				 E x F x G
<b>V91292</b> ■ 40.80 x 8.00 x 120.70	7 301 820		30°	Y	H	<b>VAG92193</b> ■ 56.00 x 8.04 x 13.05
<b>V91293</b> ■ 34.50 x 8.00 x 122.00	7 301 821		45°			<b>VAG92373</b> ■ 56.00 x 8.03 x 13.04
<b>V91294</b> ■ 34.50 x 8.00 x 122.00	7 302 157		45°		H	<b>VAG92444</b> ■ 56.00 x 8.00 x 13.04
						<b>VAG92194</b> ■ 60.00 x 8.04 x 13.05
						<b>VAG92369</b> ■ 60.00 x 8.00 x 13.07
						<b>VAG92445</b> ■ 60.00 x 8.00 x 13.04

<b>AY581</b> Fibre Composite, 1.300mm <b>AY591</b> Fibre Composite, 1.400mm <b>AB5101</b> Fibre Composite, 1200mm <b>AB5111</b> Fibre Composite, 1500mm	<b>DS381</b> ▲	<b>FB5100</b> ▲ [1]	<b>HBS011</b> Ⓢ M12x1.25x119.00mm (x12)	<b>JC054</b> ■ <b>JC055</b> ■	<b>JN956</b>	<b>HR602</b> ■	<b>NP068</b> ■ 55.00x70.00x8.00mm FPM

<b>AY581</b>	<b>AB5111</b>	<b>AY581</b>	<b>AY591</b>			
[1] Without crankshaft seal		[1] sans bague d'étanchéité - vilebrequin	[1] senza paraolio-albero a gomiti			[1] sin cigüeñal retén

**676**

**93.00**

**Diesel**



8140.67      4 Cyl.      22:1      2500cc      55-62kW (75-84)PS      TD1052      1314

<b>TB388</b> 121x15 →08/98 Length: 1152.5mm Groove Distance: 9.525	<b>TBK037</b> →08/98 Component No: TB368; AE1011TP;AE1010GP	<b>CAM718</b> 01/89→			

	OE	MAT.				
B x C x D						E x F x G
<b>V91292</b> ■ 40.80 x 8.00 x 120.70	7 301 820		30°	Y	H	<b>VAG92193</b> ■ 56.00 x 8.04 x 13.05
<b>V91293</b> ■ 34.50 x 8.00 x 122.00	7 301 821		45°			<b>VAG92373</b> ■ 56.00 x 8.03 x 13.04
<b>V91294</b> ■ 34.50 x 8.00 x 122.00	7 302 157		45°		H	<b>VAG92444</b> ■ 56.00 x 8.00 x 13.04
						<b>VAG92194</b> ■ 60.00 x 8.04 x 13.05
						<b>VAG92369</b> ■ 60.00 x 8.00 x 13.07
						<b>VAG92445</b> ■ 60.00 x 8.00 x 13.04

<b>AY290</b> Fibre Composite, 1.600mm <b>AY300</b> Fibre Composite, 1.700mm <b>AY310</b> Fibre Composite, 1.800mm	<b>DE588</b> ▲	<b>HBS011</b> Ⓢ M12x1.25x119.00mm (x12)	<b>JC054</b> ■ <b>JC055</b> ■	<b>JN596</b> <b>JN956</b>	<b>HR602</b> ■ <b>HR801</b> ■	<b>NP068</b> 55.00x70.00x8.00mm FPM

AY290, AY300, AY310

<b>677</b>	<b>93.00</b>	<b>Diesel</b>					
<b>8140.67.2585 Euro 2</b>	4 Cyl.	18.5:1	2500cc	<b>55-63kW (75-86)PS</b>	<b>Turbo Intercooled</b>	<b>TD20427</b>	<b>1316</b>

B x C x D	OE	MAT.			E x F x G	
<b>V91939</b>	98 468 338		30°	H	<b>VAG92193</b>	
43.50 x 8.00 x 122.00					56.00 x 8.04 x 13.05	
<b>V91940</b>	98 418 161		45°	H	<b>VAG92373</b>	
36.70 x 8.00 x 122.00					56.00 x 8.03 x 13.04	
					<b>VAG92444</b>	
					56.00 x 8.00 x 13.04	
					<b>VAG92194</b>	
					60.00 x 8.04 x 13.05	
					<b>VAG92369</b>	
					60.00 x 8.00 x 13.07	
					<b>VAG92445</b>	
					60.00 x 8.00 x 13.04	

<b>AY290</b> Fibre Composite, 1.600mm <b>AY300</b> Fibre Composite, 1.700mm <b>AY310</b> Fibre Composite, 1.800mm	<b>DE588</b> ▲	<b>FY291</b> ▲ [1]	<b>HBS011</b> Ⓢ M12x1.25x119.00mm (x12)	<b>JC054</b> <b>JC055</b>		<b>HR602</b>	<b>NP068</b> 55.00x70.00x8.00mm FPM <b>NP067</b> 50.00x70.00x10.00mm FPM



**AY290, AY300, AY310**

[1] Without crankshaft seal

[1] sans bague d'étanchéité - vilebrequin

[1] senza paraolio-albero a gomiti

[1] sin cigüeñal retén

<b>678</b>	<b>93.00</b>	<b>Diesel</b>				
<b>8140 SC 27.02</b>	4 Cyl.	18.5:1	2500cc	<b>62kW (84)PS</b>	<b>TD16182</b>	<b>1317</b>

<b>AY591</b> Fibre Composite, 1.400mm				<b>JC054</b> <b>JC055</b>	<b>JN594</b>		



**AY591**



8144.67

4 Cyl.

22:1

2500cc

55kW (75)PS

TD1056

1318

<b>TB368</b> 152x30 HNBR <b>TB135</b> 152x30 Polychloroprene (Neoprene)	<b>TBK045</b> Component No: TB135; AE1011TP;AE1010GP <b>TBK037</b> Component No: TB368; AE1011TP;AE1010GP	<b>CAM718</b> 01/89→			

	OE	MAT.				
B x C x D						
<b>V91292</b> ■ 40.80 x 8.00 x 120.70	7 301 820		30°	Y	H	<b>VAG92193</b> ■ 56.00 x 8.04 x 13.05
<b>V91293</b> ■ 34.50 x 8.00 x 122.00	7 301 821		45°			<b>VAG92373</b> ■ 56.00 x 8.03 x 13.04
<b>V91294</b> ■ 34.50 x 8.00 x 122.00	7 302 157		45°		H	<b>VAG92444</b> ■ 56.00 x 8.00 x 13.04
						<b>VAG92194</b> ■ 60.00 x 8.04 x 13.05
						<b>VAG92369</b> ■ 60.00 x 8.00 x 13.07
						<b>VAG92445</b> ■ 60.00 x 8.00 x 13.04

<b>AY290</b> Fibre Composite, 1.600mm <b>AY300</b> Fibre Composite, 1.700mm <b>AY310</b> Fibre Composite, 1.800mm	<b>DE588</b> ▲	<b>FY291</b> ▲ [1]	<b>HBS011</b> ◊ M12x1.25x119.00mm (x12)	<b>JC054</b> ■ (x4) <b>JC055</b> ■ (x4)	<b>JN462</b>	<b>HR602</b> ■	<b>NP068</b> 55.00x70.00x8.00mm FPM

**AY290, AY300, AY310**  
[1] Without crankshaft seal

[1] sans bague d'étanchéité - vilebrequin

[1] senza paraolio-albero a gomiti

[1] sin cigüeñal retén



<b>680</b>	<b>93.00</b>	<b>Diesel</b>					
<b>8144.97 S</b>	4 Cyl.	21:1	2500cc	<b>77kW (105)PS</b>	<b>Turbo Intercooled</b>	<b>TD1059</b>	<b>1307</b>

<b>TB348</b> 99x19 →01/93					

	OE	MAT.				
B x C x D						E x F x G
<b>V91292</b>	7 301 820		30°	Y	H	<b>VAG92193</b>
40.80 x 8.00 x 120.70		MB cr				56.00 x 8.04 x 13.05
<b>V91293</b>	7 301 821		45°			<b>VAG92373</b>
34.50 x 8.00 x 122.00		MD				56.00 x 8.03 x 13.04
<b>V91294</b>	7 302 157		45°		H	<b>VAG92444</b>
34.50 x 8.00 x 122.00		MF cr				56.00 x 8.00 x 13.04
						<b>VAG92194</b>
						60.00 x 8.04 x 13.05
						<b>VAG92369</b>
						60.00 x 8.00 x 13.07
						<b>VAG92445</b>
						60.00 x 8.00 x 13.04

<b>AY290</b> Fibre Composite, 1.600mm	<b>DP273</b> ▲	<b>HBS011</b>	<b>JC054</b>	<b>JN585</b>	<b>NPO68</b>
<b>AY300</b> Fibre Composite, 1.700mm		M12x1.25x119.00mm (x12)	<b>JC055</b>		55.00x70.00x8.00mm FPM
<b>AY310</b> Fibre Composite, 1.800mm					

**AY290, AY300, AY310**



8144. 97S      4 Cyl.      21:1      2500cc      77kW (105)PS      Turbocharged      TD1785      1319



TB348  
99x19

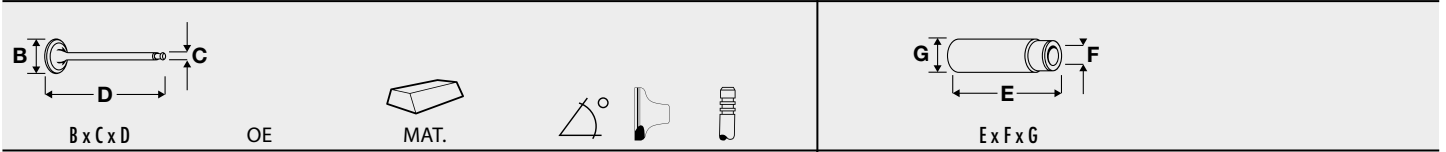

B x C x D	OE	MAT.	Angle	Y	H	E x F x G
<b>V91292</b> ■ 40.80 x 8.00 x 120.70	7 301 820	MB cr	30°	Y	H	
<b>V91293</b> ■ 34.50 x 8.00 x 122.00	7 301 821	MD	45°			
<b>V91294</b> ■ 34.50 x 8.00 x 122.00	7 302 157	MF cr	45°		H	

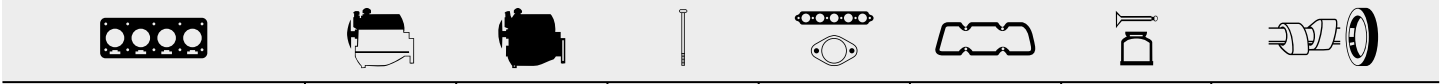

<b>AY290</b> Fibre Composite, 1.600mm <b>AY300</b> Fibre Composite, 1.700mm <b>AY310</b> Fibre Composite, 1.800mm	<b>DP273</b> ▲		<b>HBS011</b> ① M12x1.25x119.00mm (x12)	<b>JC055</b> ■	<b>JN585</b>	<b>NF841</b> 35.00x50.00x8.00mm FPM <b>NP068</b> 55.00x70.00x8.00mm FPM
---	----------------	--	--	----------------	--------------	--



AY290, AY300, AY310

<b>682</b>	<b>93.00</b>	<b>Diesel</b>					
<b>8144.97 Y</b>	4 Cyl.	22.5:1	2500cc	<b>85kW (115)PS</b>	<b>Turbo Intercooled</b>	<b>TD1060</b>	<b>1320</b>

<b>TB348</b> 99x19 →01/93					

 B x C x D	OE	MAT.			 E x F x G
<b>V91292</b> ■ 40.80 x 8.00 x 120.70	7 301 820	 MB cr	30°	Y H	<b>VAG92193</b> ■ 56.00 x 8.04 x 13.05
<b>V91293</b> ■ 34.50 x 8.00 x 122.00	7 301 821	 MD	45°		<b>VAG92373</b> ■ 56.00 x 8.03 x 13.04
<b>V91294</b> ■ 34.50 x 8.00 x 122.00	7 302 157	 MF cr	45°	H	<b>VAG92444</b> ■ 56.00 x 8.00 x 13.04
					<b>VAG92194</b> ■ 60.00 x 8.04 x 13.05
					<b>VAG92369</b> ■ 60.00 x 8.00 x 13.07
					<b>VAG92445</b> ■ 60.00 x 8.00 x 13.04

<b>AY290</b> Fibre Composite, 1.600mm <b>AY300</b> Fibre Composite, 1.700mm <b>AY310</b> Fibre Composite, 1.800mm			<b>HBS011</b> Ⓢ M12x1.25x119.00mm (x12)	<b>JC054</b> ■ <b>JC055</b> ■	<b>JN969</b>		<b>NP068</b> 55.00x70.00x8.00mm FPM

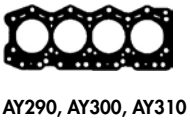

# FIAT GROUP

**683**

**93.00**

**Diesel**



8144.97 Y      4 Cyl.      22.5:1      2500cc      85kW (115)PS      Turbocharged      TD1786      1319

B x C x D	OE	MAT.				E x F x G
<b>V91292</b> ■ 40.80 x 8.00 x 120.70	7 301 820	MB cr	30°	Y	H	<b>VAG92193</b> ■ 56.00 x 8.04 x 13.05
<b>V91293</b> ■ 34.50 x 8.00 x 122.00	7 301 821	MD	45°			<b>VAG92373</b> ■ 56.00 x 8.03 x 13.04
<b>V91294</b> ■ 34.50 x 8.00 x 122.00	7 302 157	MF cr	45°		H	<b>VAG92444</b> ■ 56.00 x 8.00 x 13.04
						<b>VAG92194</b> ■ 60.00 x 8.04 x 13.05
						<b>VAG92369</b> ■ 60.00 x 8.00 x 13.07
						<b>VAG92445</b> ■ 60.00 x 8.00 x 13.04

AY290 Fibre Composite, 1.600mm AY300 Fibre Composite, 1.700mm AY310 Fibre Composite, 1.800mm			HBS011 ① M12x1.25x119.00mm (x12)	JC054 ■ JC055 ■	JN969		NP068 55.00x70.00x8.00mm FPM

AY290, AY300, AY310

**684**

**93.00**

**Diesel**



CRD93L (U25-661)      4 Cyl.      22.25:1      2500cc      54-55kW (73-75)PS      TD22981      1321

<b>TB368</b> 152x30 HNBR <b>TB135</b> 152x30 Polychloroprene (Neoprene)	<b>TBK045</b> Component No: TB135; AE1011TP;AE1010GP <b>TBK037</b> Component No: TB368; AE1011TP;AE1010GP			<b>KIT</b>			

AY290 Fibre Composite, 1.600mm AY300 Fibre Composite, 1.700mm AY310 Fibre Composite, 1.800mm		<b>FY291</b> ▲ [1]	HBS011 ① M12x1.25x119.00mm (x12)	JC054 ■ (x4) JC055 ■ (x4)	JN462	HR602 ■	NP068 55.00x70.00x8.00mm FPM

AY290, AY300, AY310  
[1] Without crankshaft seal

[1] sans bague d'étanchéité - vilebrequin      [1] senza paraolio-albero a gomiti      [1] sin cigüeñal retén

<b>685</b>	<b>93.00</b>	<b>Petrol</b>							
<b>834 F.000</b>	6 Cyl.	2959cc	<b>126kW (171)PS</b>	<b>TD1841</b>	<b>1322</b>				
<b>TB383</b> 134x25.4									
	OE								
					<b>VAG96263</b>				
					48.50 x 9.00 x 14.05				
					<b>JD222</b>	<b>JN808</b>	<b>JN807</b>	<b>NA5163</b>	32.00x47.00x10.00mm FPM

<b>686</b>	<b>93.00</b>	<b>Petrol</b>							
<b>838 B.000</b>	6 Cyl.	10:1	2959cc	<b>150kW (204)PS</b>	<b>TD4620</b>	<b>1323</b>			
<b>TB531</b> 174x28 Eng.→2051777									
<b>TB532</b> 185x28 Eng.2051778 →									
						<b>HR662</b>	<b>NA5001</b>	32.00x47.00x10.00mm FPM	

<b>687</b>	<b>93.00</b>	<b>Petrol</b>							
<b>841 A.000</b>	6 Cyl.	10:1	2959cc	<b>158kW (215)PS</b>	<b>TD16733</b>	<b>1324</b>			
<b>TB532</b> 185x28 →07/05									
<b>BT381</b> Fibre Composite, 1650mm	<b>CY640</b>	<b>FY640</b>	<b>HBS272</b>	M10x1.50x147.00mm (x16)	<b>JP071</b>	<b>HR662</b>	<b>NA5163</b>	32.00x47.00x10.00mm FPM	
<b>AY641</b> Fibre Composite, 1650mm					<b>JP070</b>				
<b>AY641</b>	<b>BT381</b>								

# FIAT GROUP

<b>688</b>	93.00	<b>Petrol</b>			
AR 06120	6 Cyl.	9.5:1	2959cc	<b>133-136kW</b> (181-185)PS	<b>TD48 1325</b>
AR 06124	6 Cyl.	9.5:1	2959cc	<b>136-138kW</b> (185-188)PS	<b>TD49 1325</b>
AR 61503	6 Cyl.	9.5:1	2959cc	<b>139-141kW</b> (189-192)PS	<b>TD51 1325</b>

	.KIT		KIT		
<b>TB134</b> 134x25.4					<b>FOL129</b> (x12)

B x C x D	OE	MAT.			E x F x G
					<b>VAG96197B</b> 38.00 x 7.04 x 12.08 <b>VAG96184</b> 43.00 x 7.04 x 12.08

















	<b>DW260</b>			<b>JD222</b> (x2) <b>JD223</b> (x6) <b>JD224</b>	<b>JN808</b> <b>JN807</b>		<b>NA5163</b> 32.00x47.00x10.00mm FPM





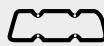

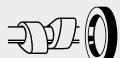











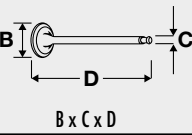



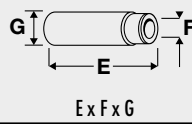





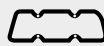

<b>689</b>	93.00	<b>Petrol</b>			
AR 06410	6 Cyl.		2959cc	<b>136-141kW</b> (184-192)PS	<b>TD59 1326</b>
AR 06412	6 Cyl.		2959cc	<b>135kW</b> (184)PS	<b>TD61 1326</b>

	.KIT		KIT		
<b>TB134</b> 134x25.4					

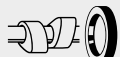
B x C x D	OE	MAT.			E x F x G
					<b>VAG96197B</b> 38.00 x 7.04 x 12.08 <b>VAG96184</b> 43.00 x 7.04 x 12.08

	<b>DW260</b>			<b>JD222</b> (x2) <b>JD223</b> (x6) <b>JD224</b>	<b>JN808</b> <b>JN807</b>		<b>NA5163</b> 32.00x47.00x10.00mm FPM

<b>690</b>	 <b>93.00</b>	<b>Petrol</b>					
AR 06430	6 Cyl.	10:1	2959cc	147kW (200)PS	TD64	<b>1324</b>	
							
<b>TB134</b> 134x25.4						<b>FOL129</b> (x12)	
							
				<b>JD224</b> 		<b>NA5163</b> 32.00x47.00x10.00mm FPM	

<b>691</b>	 <b>93.00</b>	<b>Petrol</b>					
AR 16101	6 Cyl.	10:1	2959cc	141kW (192)PS	TD4187	<b>1327</b>	
							
<b>TB383</b> 134x25.4 →08/01						<b>FOL129</b> (x12)	
 B x C x D	OE	 MAT.			 E x F x G		
					<b>VAG96197B</b>  38.00 x 7.04 x 12.08		
					<b>VAG96184</b>  43.00 x 7.04 x 12.08		
							
	<b>DW261</b>			<b>JD222</b>  (x2) <b>JD223</b>  (x6) <b>JD224</b> 	<b>JM5023</b>  (Steel Elastomer) <b>JM5024</b>  (Steel Elastomer)	<b>HR815</b> 	<b>NJ951</b> 32.00x50.00x8.00mm FPM <b>NA5163</b> 32.00x47.00x10.00mm FPM

# FIAT GROUP







**692**

 **93.00**

**Petrol**







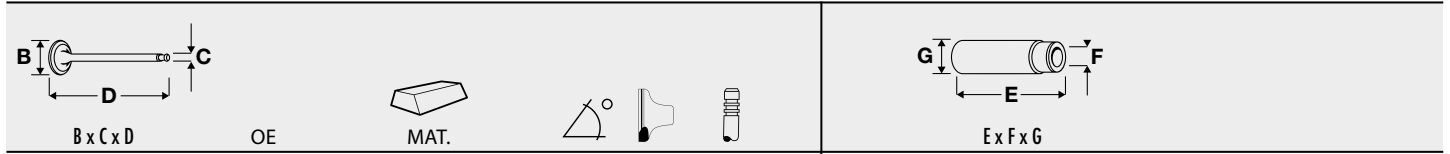









AR 16102      6 Cyl.      10.1:1      2959cc      162kW (220)PS      TD5495      **1323**

					
<b>TB532</b> 185x28 09/00 →					



**VAG96197B**   
38.00 x 7.04 x 12.08  
**VAG96184**   
43.00 x 7.04 x 12.08

							
<b>BT381</b> Fibre Composite, 1650mm 	<b>CY640</b>	<b>FY640</b>		<b>JD586</b>  (x2) <b>JD587</b>  (x6)	<b>JP071</b>  <b>JP070</b> 		<b>NA5163</b> 32.00x47.00x10.00mm FPM
<b>AY641</b> Fibre Composite, 1650mm 							

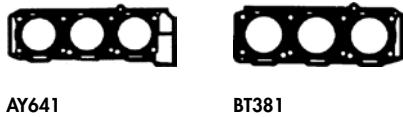







**693**

 **93.00**



**Petrol**





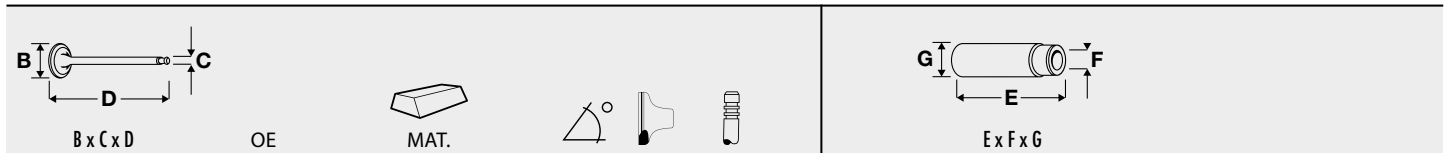











AR 16105      6 Cyl.      2959cc      160kW (218)PS      TD15970      **1323**

					
<b>TB532</b> 185x28 →03/03					















**VAG96197B**   
38.00 x 7.04 x 12.08  
**VAG96184**   
43.00 x 7.04 x 12.08





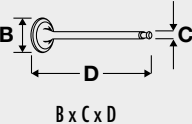
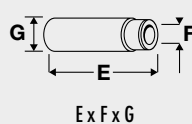









							
<b>BT381</b> Fibre Composite, 1650mm 	<b>CY640</b>	<b>FY640</b>		<b>JD586</b>  (x2) <b>JD587</b>  (x6)	<b>JP071</b>  <b>JP070</b> 		<b>NA5163</b> 32.00x47.00x10.00mm FPM
<b>AY641</b> Fibre Composite, 1650mm 							



















<b>694</b>  <b>93.00</b> <b>Petrol</b> 			
AR 34301	6 Cyl. 10:1 2959cc 166kW (226)PS TD11603 <b>1323</b>		
 	 		
<b>TB532</b> 185x28			

	
B x C x D	E x F x G
OE	
	
	<b>VAG96184</b>  43.00 x 7.04 x 12.08

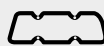
						
<b>BT381</b> Fibre Composite, 1650mm 	<b>CY640</b>	<b>FY640</b>	<b>JD586</b>  (x2) <b>JD587</b>  (x6)	<b>JP071</b>  <b>JP070</b> 		<b>NA5163</b> 32.00x47.00x10.00mm FPM
						
<b>AY641</b>	<b>BT381</b>					

<b>695</b>  <b>93.00</b> <b>Petrol</b> 						
AR 34302	6 Cyl. 10:1 2959cc 166kW (226)PS TD23348 <b>1324</b>					
 	 					
<b>TB532</b> 185x28						
						
						<b>NA5258</b> 27.00x47.00x7.00mm PTFE

# FIAT GROUP

<b>696</b>	<b>93.00</b>	<b>Petrol</b>			
AR 36101	6 Cyl.	2959cc	162kW (220)PS	TD15393	<b>1323</b>
<b>TB532</b> 185x28 →09/07					

	OE				
B x C x D		MAT.			E x F x G
					<b>VAG96197B</b> 38.00 x 7.04 x 12.08 <b>VAG96184</b> 43.00 x 7.04 x 12.08

<b>BT381</b> Fibre Composite, 1650mm	<b>CY640</b>	<b>FY640</b>		<b>JD586</b> (x2)	<b>JP071</b>		<b>NA5163</b> 32.00x47.00x10.00mm FPM
<b>AY641</b> Fibre Composite, 1650mm				<b>JD587</b> (x6)	<b>JP070</b>		
<b>AY641</b>	<b>BT381</b>						

<b>697</b>	<b>93.00</b>	<b>Petrol</b>				
AR 61501	6 Cyl.	10:1	2959cc	151-155kW (205-211)PS	TD104 <b>1324</b>	
<b>TB134</b> 134x25.4						
				<b>JD224</b>		<b>NA5001</b> 32.00x47.00x10.00mm FPM

<b>698</b>	<b>93.00</b>	<b>Petrol</b>				
AR 64301	6 Cyl.	10:1	2959cc	147kW (200)PS	TD106	<b>1326</b>
<b>TB134</b> 134x25.4						<b>FOL129</b> (x12)

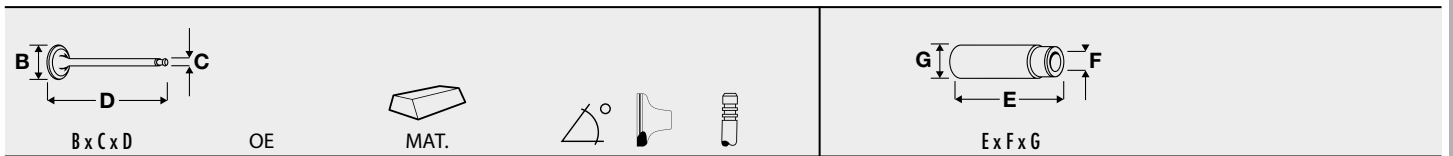

**VAG96197B**   
38.00 x 7.04 x 12.08

**VAG96184**   
43.00 x 7.04 x 12.08

					<b>JD224</b>			<b>NA5163</b> 32.00x47.00x10.00mm FPM

<b>699</b>	<b>93.00</b>	<b>Petrol</b>				
AR 64303	6 Cyl.		2959cc	132kW (180)PS	TD29541	<b>1328</b>
<b>TB383</b> 134x25.4 →10/97						

<b>700</b>	<b>93.00</b>	<b>Petrol</b>				
AR 64304	6 Cyl.		2959cc	168-171kW (228-233)PS	TD124	<b>1328</b>
<b>TB531</b> 174x28 →10/97						

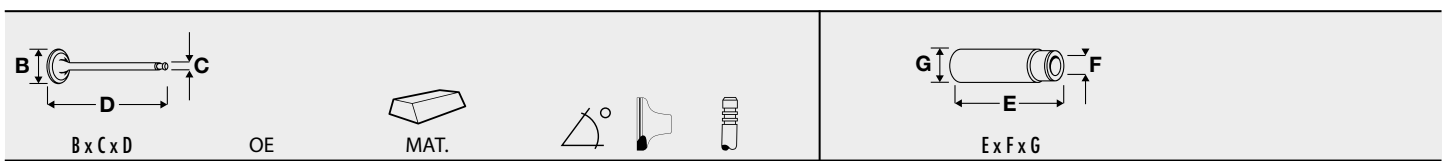

**VAG96197B**   
38.00 x 7.04 x 12.08





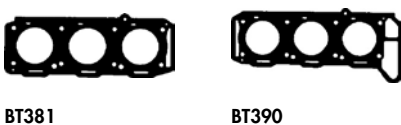















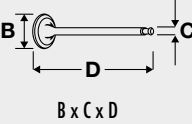



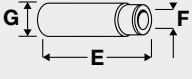

**VAG96184**   
43.00 x 7.04 x 12.08





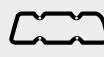





<b>BT381</b> Fibre Composite, 1650mm	<b>BT390</b> Fibre Composite	<b>GK573</b>			<b>JP068</b> <b>JN813</b> <b>JN814</b>	<b>HR800</b>	<b>NA5163</b> 32.00x47.00x10.00mm FPM	



**BT381**      **BT390**

# FIAT GROUP

<b>701</b>		 <b>93.00</b>	<b>Petrol</b>		
<b>AR 64305</b>	6 Cyl.	2959cc	<b>132kW (180)PS</b>		<b>TD125</b> <b>1327</b>
<b>AR 66303</b>	6 Cyl.	2959cc	<b>132kW (180)PS</b>		<b>TD92</b> <b>1327</b>
 	 				
<b>TB383</b> 134x25.4 →10/97					<b>FOL129</b> (x12)
 $B \times C \times D$	OE	 MAT.	  	 $E \times F \times G$	
				<b>VAG96197B</b>  38.00 x 7.04 x 12.08	
				<b>VAG96184</b>  43.00 x 7.04 x 12.08	
					  
				<b>JD224</b> 	<b>NJ951</b> 32.00x50.00x8.00mm FPM <b>NA5163</b> 32.00x47.00x10.00mm FPM

<b>702</b>		 <b>93.00</b>	<b>Petrol</b>		
<b>AR 64306</b>	6 Cyl.	9.5:1 2959cc	<b>132-170kW (180-231)PS</b>		<b>TD25829</b> <b>1324</b>
 	 				
<b>TB531</b> 174x28 →10/97					

<b>703</b>	<b>93.00</b>	<b>Petrol</b>						
AR 64307	6 Cyl.	2959cc	170kW (231)PS					TD148 <b>1324</b>
<b>TB531</b> 174x28 →10/97								

	OE			<b>VAG96197B</b> 38.00 x 7.04 x 12.08	
B x C x D			Ex F x G	<b>VAG96184</b> 43.00 x 7.04 x 12.08	

<b>BT381</b> Fibre Composite, 1650mm								<b>NA5163</b> 32.00x47.00x10.00mm FPM
<b>AY641</b> Fibre Composite, 1650mm								
<b>AY641</b>	<b>BT381</b>							

<b>704</b>	<b>93.00</b>	<b>Petrol</b>						
AR 64308	6 Cyl.	10:1	2959cc	150-170kW (204-231)PS				TD126 <b>1324</b>
AR 66301	6 Cyl.		2959cc	152-155kW (207-211)PS				TD130 <b>1324</b>
AR 66302	6 Cyl.		2959cc	151-155kW (205-211)PS				TD131 <b>1324</b>











<b>TB531</b> 174x28 →10/97								





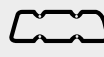

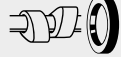

<b>BT381</b> Fibre Composite, 1650mm								<b>NA5163</b> 32.00x47.00x10.00mm FPM
<b>BT381</b>								















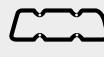

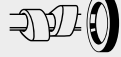
<b>705</b>	<b>93.00</b>	<b>Petrol</b>						
AR 64399	6 Cyl.	2959cc	132-145kW (180-197)PS					TD21728 <b>1324</b>









<b>TB383</b> 134x25.4 →10/97								
				<b>JD224</b>				















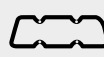

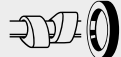
# FIAT GROUP



<b>706</b>	 <b>93.00</b>	<b>Petrol</b>	
AR 66306	6 Cyl.	2959cc	157kW (214)PS
			TD21729 <b>1324</b>
			
			
			
			
			
			HR662 

<b>707</b>	 <b>93.00</b>	<b>Petrol</b>	
932 A.000	6 Cyl.	3179cc	184kW (250)PS
			TD16380
	 <b>.KIT</b>		 <b>KIT</b>
			
<b>TB532</b> 185x28 →09/06			







							
<b>BT381</b> Fibre Composite, 1650mm 	<b>CY640</b>	 <b>FY640</b>		<b>JD586</b> 	<b>JP071</b> 	<b>HR662</b> 	<b>NA5001</b>
<b>AY641</b> Fibre Composite, 1650mm 				<b>JD587</b> 	<b>JP070</b> 		32.00x47.00x10.00mm FPM
							
<b>AY641</b>	<b>BT381</b>						













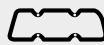

<b>708</b>	 <b>93.00</b>	<b>Petrol</b>	
936 A.000	6 Cyl.	3179cc	176kW (240)PS
			TD18077
	 <b>.KIT</b>		 <b>KIT</b>
			
<b>TB532</b> 185x28 →09/07			

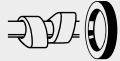
							
<b>BT381</b> Fibre Composite, 1650mm 	<b>CY640</b>	 <b>FY640</b>		<b>JD586</b> 	<b>JP071</b> 	<b>HR662</b> 	<b>NA5001</b>
<b>AY641</b> Fibre Composite, 1650mm 				<b>JD587</b> 	<b>JP070</b> 		32.00x47.00x10.00mm FPM
							
<b>AY641</b>	<b>BT381</b>						



**709**  **93.00** **Petrol** 

936 A6.000      6 Cyl.      3179cc      176kW (240)PS      TD18311



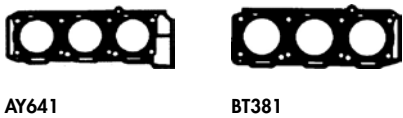







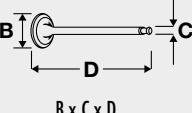

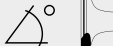
					
<b>TB532</b> 185x28 →10/04					

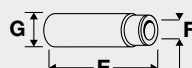









							
<b>BT381</b> Fibre Composite, 1650mm 	<b>CY640</b>	<b>FY640</b>		<b>JD586</b> 	<b>JP071</b> 	<b>HR662</b> 	<b>NA5001</b> 32.00x47.00x10.00mm FPM
<b>AY641</b> Fibre Composite, 1650mm 				<b>JD587</b> 	<b>JP070</b> 		

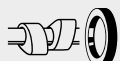

**710**  **94.40** **Diesel** 

8140.23.      4 Cyl.      18.5:1      2798cc      76kW (103)PS      Turbo Intercooled      TD7229      1329

				
B x C x D	OE	MAT.		E x F x G
<b>V91292</b> 	7 301 820		30°    Y    H	<b>VAG92373</b> 
40.80 x 8.00 x 120.70		MB cr		56.00 x 8.03 x 13.04
<b>V91994</b> 	99 432 837		45°	<b>VAG92444</b> 
35.80 x 8.00 x 121.90		MD cr		56.00 x 8.00 x 13.04
				<b>VAG92369</b> 
				60.00 x 8.00 x 13.07
				<b>VAG92445</b> 
				60.00 x 8.00 x 13.04

							
<b>BX401</b> Fibre Composite, 1300mm	<b>DX390</b> 			<b>JC054</b> 	<b>JN596</b>		<b>NP068</b>
<b>BX411</b> Fibre Composite, 1400mm	<b>DX391</b> 			<b>JC055</b> 			55.00x70.00x8.00mm FPM
<b>BX421</b> Fibre Composite, 1500mm							

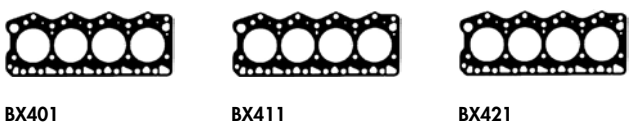

## 711



### 94.40

### Diesel



8140.23.2585 Euro 2	4 Cyl.	18.5:1	2799cc	78kW (106)PS	Turbo Intercooled	TD16183	1331
8140.23.3700 Euro 2	4 Cyl.	18.5:1	2798cc	76kW (103)PS	Turbo Intercooled	TD10387	1331

B x C x D	OE	MAT.	Angle	Material	Height	E x F x G	
<b>V91292</b> ■ 40.80 x 8.00 x 120.70	7 301 820	 MB cr	30°	Y	H		
<b>V91994</b> ■ 35.80 x 8.00 x 121.90	99 432 837	 MD cr	45°				



<b>BX391</b> Fibre Composite, 1200mm <b>BX401</b> Fibre Composite, 1300mm <b>BX411</b> Fibre Composite, 1400mm <b>BX421</b> Fibre Composite, 1500mm	<b>DX390</b> ▲ <b>DX391</b> ▲	<b>GX410</b> ▲	<b>HBS011</b> ⊕ M12x1.25x119.00mm (x12) <b>HBS255</b> ⊕ M12x1.25x160.00mm (x8)	<b>JC054</b> ■ <b>JC055</b> ■	<b>HR602</b> ■	<b>NP068</b> 55.00x70.00x8.00mm FPM <b>NP067</b> 50.00x70.00x10.00mm FPM
--	----------------------------------	----------------	---	----------------------------------	----------------	---



BX391



BX401



BX411



BX421



## 712

## 94.40

## Diesel



8140.23.3701 Euro 2	4 Cyl.	18.5:1	2798cc	76kW (103)PS	Turbo Intercooled	TD27373	1332
8140.23.3710 Euro 2	4 Cyl.	18.5:1	2798cc	76kW (103)PS	Turbo Intercooled	TD27374	1332
8140.23.3711 Euro 2	4 Cyl.	18.5:1	2798cc	76kW (103)PS	Turbo Intercooled	TD27375	1332
8140.23.3713 Euro 2	4 Cyl.	18.5:1	2798cc	76kW (103)PS	Turbo Intercooled	TD27376	1332
8140.23.3720 Euro 2	4 Cyl.	18.5:1	2798cc	76kW (103)PS	Turbo Intercooled	TD27377	1332
8140.23.3721 Euro 2	4 Cyl.	18.5:1	2798cc	76kW (103)PS	Turbo Intercooled	TD27378	1332
8140.23.3730 Euro 2	4 Cyl.	18.5:1	2798cc	76kW (103)PS	Turbo Intercooled	TD27379	1332
8140.23.3731 Euro 2	4 Cyl.	18.5:1	2798cc	76kW (103)PS	Turbo Intercooled	TD27380	1332
8140.23.3750 Euro 2	4 Cyl.	18.5:1	2798cc	76kW (103)PS	Turbo Intercooled	TD27381	1332
8140.23.3751 Euro 2	4 Cyl.	18.5:1	2798cc	76kW (103)PS	Turbo Intercooled	TD27382	1332
8140.43N.4300 Euro 3 (D3)	4 Cyl.	18.5:1	2798cc	108kW (147)PS	Turbo Intercooled	TD25984	1338
8140.43N.4320 Euro 3 (D3)	4 Cyl.	18.5:1	2798cc	108kW (147)PS	Turbo Intercooled	TD25985	1338
8140.43N.4330 Euro 3 (D3)	4 Cyl.	18.5:1	2798cc	108kW (147)PS	Turbo Intercooled	TD25986	1338
8140.43N.4400 Euro 3 (D3)	4 Cyl.	18.5:1	2798cc	108kW (147)PS	Turbo Intercooled	TD25987	1338
8140.43N.4430 Euro 3 (D3)	4 Cyl.	18.5:1	2798cc	108kW (147)PS	Turbo Intercooled	TD25988	1338
8140.43R.4300 Euro 3 (D3)	4 Cyl.	18.5:1	2798cc	66kW (90)PS	Turbo Intercooled	TD25989	1332
8140.43R.4320 Euro 3 (D3)	4 Cyl.	18.5:1	2798cc	66kW (90)PS	Turbo Intercooled	TD25990	1332
8140.43R.4330 Euro 3 (D3)	4 Cyl.	18.5:1	2798cc	66kW (90)PS	Turbo Intercooled	TD25991	1332
8140.43R.4400 Euro 3 (D3)	4 Cyl.	18.5:1	2798cc	66kW (90)PS	Turbo Intercooled	TD25992	1332
8140.43R.4420 Euro 3 (D3)	4 Cyl.	18.5:1	2798cc	66kW (90)PS	Turbo Intercooled	TD25993	1332
8140.43S.4000 Euro 3 (D3)	4 Cyl.	18.5:1	2798cc	92kW (125)PS	Turbo Intercooled	TD25995	1338
8140.43S.4020 Euro 3 (D3)	4 Cyl.	18.5:1	2798cc	92kW (125)PS	Turbo Intercooled	TD25996	1338
8140.43S.4030 Euro 3 (D3)	4 Cyl.	18.5:1	2798cc	92kW (125)PS	Turbo Intercooled	TD25997	1338
8140.43S.4140 Euro 3 (D3)	4 Cyl.	18.5:1	2798cc	92kW (125)PS	Turbo Intercooled	TD25998	1338
8140.43S.4300 Euro 3 (D3)	4 Cyl.	18.5:1	2798cc	92kW (125)PS	Turbo Intercooled	TD25999	1338
8140.43S.4320 Euro 3 (D3)	4 Cyl.	18.5:1	2798cc	92kW (125)PS	Turbo Intercooled	TD26000	1338
8140.43S.4330 Euro 3 (D3)	4 Cyl.	18.5:1	2798cc	92kW (125)PS	Turbo Intercooled	TD26001	1338
8140.43S.4400 Euro 3 (D3)	4 Cyl.	18.5:1	2798cc	92kW (125)PS	Turbo Intercooled	TD26002	1338
8140.43S.4420 Euro 3 (D3)	4 Cyl.	18.5:1	2798cc	92kW (125)PS	Turbo Intercooled	TD26003	1338
8140.43S.4430 Euro 3 (D3)	4 Cyl.	18.5:1	2798cc	92kW (125)PS	Turbo Intercooled	TD26004	1338

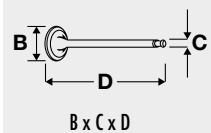

OE

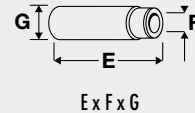

**V91292** ■  
40.80 x 8.00 x 120.70  
**V91994** ■  
35.80 x 8.00 x 121.90

7 301 820  
99 432 837

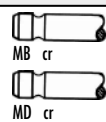

45°

**VAG92373** ■  
56.00 x 8.03 x 13.04  
**VAG92444** ■  
56.00 x 8.00 x 13.04  
**VAG92369** ■  
60.00 x 8.00 x 13.07  
**VAG92445** ■  
60.00 x 8.00 x 13.04

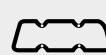
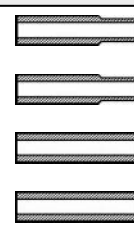

**NPO68**  
55.00x70.00x8.00mm FPM

# FIAT GROUP

## 713

 94.40

**Diesel**



8140.23.3760 Euro 2

4 Cyl.

18.5:1

2798cc

76kW (103)PS

Turbo Intercooled

TD27383

**1332**

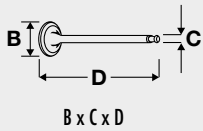

OE

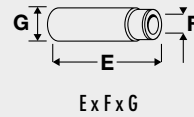

**V91292**   
40.80 x 8.00 x 120.70

7 301 820

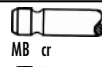

30°

Y

H

**VAG92373**   
56.00 x 8.03 x 13.04



**V91994**   
35.80 x 8.00 x 121.90

99 432 837

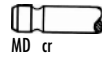

45°

**VAG92444**   
56.00 x 8.00 x 13.04



**VAG92369**   
60.00 x 8.00 x 13.07



**VAG92445**   
60.00 x 8.00 x 13.04

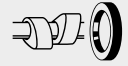
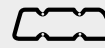

BX411 Fibre Composite, 1400mm

NPO68

55.00x70.00x8.00mm FPM



BX411

## 714

 94.40

**Diesel**



8140.23.3801 Euro 2

4 Cyl.

18.5:1

2798cc

76kW (103)PS

Turbo Intercooled

TD27384

**1332**

8140.23.3811 Euro 2

4 Cyl.

18.5:1

2798cc

76kW (103)PS

Turbo Intercooled

TD27385

**1332**

8140.23.3821 Euro 2

4 Cyl.

18.5:1

2798cc

76kW (103)PS

Turbo Intercooled



TD27386

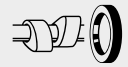
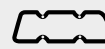









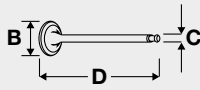
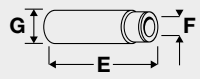



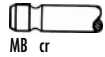

**1332**



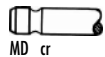











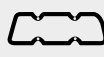

NPO68











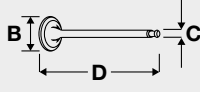
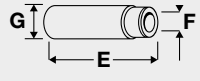



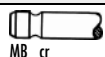

55.00x70.00x8.00mm FPM

<b>715</b>	 <b>94.40</b>	<b>Diesel</b>					
<b>8140.43.2585 Euro 2</b>	4 Cyl.	18.5:1	2798cc	<b>84-90kW (114-122)PS</b>	<b>Turbo Intercooled</b>	<b>TD20423</b>	<b>1329</b>
<b>8140.43.3700 Euro 2</b>	4 Cyl.	18.5:1	2798cc	<b>85kW (116)PS</b>	<b>Turbo Intercooled</b>	<b>TD20424</b>	<b>1329</b>
<b>8140.43.3900 Euro 2</b>	4 Cyl.	18.5:1	2798cc	<b>84-90kW (114-122)PS</b>	<b>Turbo Intercooled</b>	<b>TD20425</b>	<b>1329</b>

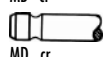
							
B x C x D	OE	MAT.				E x F x G	
<b>V91292</b> 	7 301 820	 MB cr	30°	Y	H	<b>VAG92373</b> 	
40.80 x 8.00 x 120.70						<b>VAG92444</b> 	
<b>V91994</b> 	99 432 837	 MD cr	45°			<b>VAG92369</b> 	
35.80 x 8.00 x 121.90						<b>VAG92445</b> 	
						60.00 x 8.00 x 13.04	

							
<b>BX401</b> Fibre Composite, 1300mm				<b>JC054</b> 	<b>JN956</b>		
<b>BX411</b> Fibre Composite, 1400mm				<b>JC055</b> 			
<b>BX421</b> Fibre Composite, 1500mm							
							
<b>BX401</b>	<b>BX411</b>	<b>BX421</b>					

<b>716</b>	 <b>94.40</b>	<b>Diesel</b>					
<b>8140.43.3728 Euro 2</b>	4 Cyl.	18.5:1	2798cc	<b>77-85kW (105-116)PS</b>	<b>Turbo Intercooled</b>	<b>TD27432</b>	<b>1332</b>

							
B x C x D	OE	MAT.				E x F x G	
<b>V91292</b> 	7 301 820	 MB cr	30°	Y	H	<b>VAG92373</b> 	
40.80 x 8.00 x 120.70						<b>VAG92444</b> 	
<b>V91994</b> 	99 432 837	 MD cr	45°			<b>VAG92369</b> 	
35.80 x 8.00 x 121.90						<b>VAG92445</b> 	
						60.00 x 8.00 x 13.04	

# FIAT GROUP

## 717

### 94.40

### Diesel



8140.43. Euro 2

4 Cyl.

18.5:1

2798cc

90kW (122)PS

Turbo Intercooled

TD7235

1333

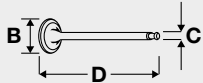

B x C x D

OE



MAT.



30°

Y



H

V91292 ■  
40.80 x 8.00 x 120.70

7 301 820

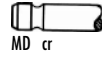
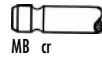

V91994 ■  
35.80 x 8.00 x 121.90

99 432 837



E x F x G

VAG92373 ■

56.00 x 8.03 x 13.04

VAG92444 ■

56.00 x 8.00 x 13.04

VAG92369 ■

60.00 x 8.00 x 13.07

VAG92445 ■

60.00 x 8.00 x 13.04

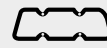

BX401 Fibre Composite, 1300mm  
BX411 Fibre Composite, 1400mm  
BX421 Fibre Composite, 1500mm

DX390 ▲

HB5011 ◊  
M12x1.25x119.00mm (x12)

JC054 ■  
JC055 ■

JN956

HR602 ■

NPO68  
55.00x70.00x8.00mm FPM



BX401

BX411

BX421

## 718

### 94.40

### Diesel



8140.43B.4300 Euro 3 (D3)

4 Cyl.

18:1

2798cc

77kW (105)PS

Turbo Intercooled

TD25968

1334

8140.43B.4305 Euro 3 (D3)

4 Cyl.

18:1

2798cc

77kW (105)PS

Turbo Intercooled

TD25966

1334

8140.43B.4325 Euro 3 (D3)

4 Cyl.

18:1

2798cc

77kW (105)PS

Turbo Intercooled

TD25969

1334

8140.43B.4330 Euro 3 (D3)

4 Cyl.

18:1

2798cc

77kW (105)PS

Turbo Intercooled

TD25970

1334

8140.43B.4335 Euro 3 (D3)

4 Cyl.

18:1

2798cc

77kW (105)PS

Turbo Intercooled

TD25971

1334

8140.43C.4000 Euro 3 (D3)

4 Cyl.

18.5:1

2798cc

77kW (105)PS

Turbo Intercooled

TD25972

1332

8140.43C.4005 Euro 3 (D3)

4 Cyl.

18.5:1

2798cc

77kW (105)PS

Turbo Intercooled

TD25973

1332

8140.43C.4025 Euro 3 (D3)

4 Cyl.

18.5:1

2798cc

77kW (105)PS

Turbo Intercooled

TD25976

1332

8140.43C.4026 Euro 3 (D3)

4 Cyl.

18.5:1

2798cc

77kW (105)PS

Turbo Intercooled

TD25977

1332

8140.43K.4020 Euro 3 (D3)

4 Cyl.

18.5:1

2798cc

92kW (125)PS

Turbo Intercooled

TD25982

1332

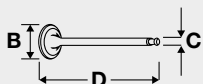

B x C x D

OE



MAT.



30°

H

V91939 ■  
43.50 x 8.00 x 122.00

98 468 338

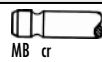

V91940 ■  
36.70 x 8.00 x 122.00

98 418 161

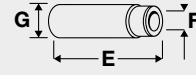
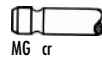

E x F x G

VAG92373 ■

56.00 x 8.03 x 13.04

VAG92444 ■

56.00 x 8.00 x 13.04

VAG92369 ■

60.00 x 8.00 x 13.07

VAG92445 ■

60.00 x 8.00 x 13.04

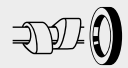
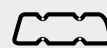

NPO68  
55.00x70.00x8.00mm FPM

<b>719</b>	<b>94.40</b>	<b>Diesel</b>						
<b>8140.43B.4320 Euro 3 (D3)</b>	4 Cyl.	18:1	2798cc	<b>77kW (105)PS</b>	<b>Turbo Intercooled</b>	<b>TD25967</b>	<b>1334</b>	
<b>8140.43C.4036 Euro 3 (D3)</b>	4 Cyl.	18.5:1	2798cc	<b>77kW (105)PS</b>	<b>Turbo Intercooled</b>	<b>TD25981</b>	<b>1332</b>	

 B x C x D			OE	MAT.	 30°	 H	 E x F x G	
<b>V91939</b>	98 468 338			30°	H	<b>VAG92373</b>		56.00 x 8.03 x 13.04
<b>V91940</b>	98 418 161			45°	H	<b>VAG92444</b>		56.00 x 8.00 x 13.04
						<b>VAG92369</b>		60.00 x 8.00 x 13.07
						<b>VAG92445</b>		60.00 x 8.00 x 13.04

<b>BX401</b> Fibre Composite, 1300mm								<b>NPO68</b> 55.00x70.00x8.00mm FPM



**BX401**

<b>720</b>	<b>94.40</b>	<b>Diesel</b>						
<b>8140.43B Euro 3 (D3)</b>	4 Cyl.	18.5:1	2798cc	<b>78kW (105)PS</b>	<b>Turbo Intercooled</b>	<b>TD16514</b>	<b>1335</b>	

 B x C x D			OE	MAT.	 30°	 H	 E x F x G	
<b>V91939</b>	98 468 338			30°	H	<b>VAG92373</b>		56.00 x 8.03 x 13.04
<b>V91940</b>	98 418 161			45°	H	<b>VAG92444</b>		56.00 x 8.00 x 13.04
						<b>VAG92369</b>		60.00 x 8.00 x 13.07
						<b>VAG92445</b>		60.00 x 8.00 x 13.04

<b>BX401</b> Fibre Composite, 1300mm	<b>DX400</b>		<b>HBS011</b>	<b>JC054</b>	<b>JN956</b>	<b>HR602</b>		
<b>BX411</b> Fibre Composite, 1400mm			M12x1.25x119.00mm (x12)	<b>JC055</b>				
<b>BX421</b> Fibre Composite, 1500mm								



**BX401**



**BX411**



**BX421**

# FIAT GROUP

## 721



94.40

Diesel



8140.43C.4020 Euro 3 (D3)	4 Cyl.	18.5:1	2798cc	77kW (105)PS	Turbo Intercooled	TD25974	1332
8140.43C.4021 Euro 3 (D3)	4 Cyl.	18.5:1	2798cc	77kW (105)PS	Turbo Intercooled	TD25975	1332

 B x C x D		OE	MAT.	 30°	 H	 E x F x G	
<b>V91939</b>	98 468 338		30°	H	<b>VAG92373</b>		56.00 x 8.03 x 13.04
43.50 x 8.00 x 122.00					<b>VAG92444</b>		56.00 x 8.00 x 13.04
<b>V91940</b>	98 418 161		45°	H	<b>VAG92369</b>		60.00 x 8.00 x 13.07
36.70 x 8.00 x 122.00					<b>VAG92445</b>		60.00 x 8.00 x 13.04

BX421 Fibre Composite, 1500mm							NP068 55.00x70.00x8.00mm FPM



BX421

## 722



94.40

Diesel



8140.43C.4030 Euro 3 (D3)	4 Cyl.	18.5:1	2798cc	77kW (105)PS	Turbo Intercooled	TD25978	1332
8140.43C.4031 Euro 3 (D3)	4 Cyl.	18.5:1	2798cc	77kW (105)PS	Turbo Intercooled	TD25979	1332

BX421 Fibre Composite, 1500mm							NP068 55.00x70.00x8.00mm FPM



BX421

<b>723</b>	<b>94.40</b>	<b>Diesel</b>					
<b>8140.43C.4035 Euro 3 (D3)</b>	4 Cyl.	18.5:1	2798cc	<b>77kW (105)PS</b>	<b>Turbo Intercooled</b>	<b>TD25980</b>	<b>1332</b>

 B x C x D				 E x F x G			
OE	MAT.						
<b>V91939</b> ■ 43.50 x 8.00 x 122.00	98 468 338 MB cr		30°	H	<b>VAG92373</b> ■ 56.00 x 8.03 x 13.04		
<b>V91940</b> ■ 36.70 x 8.00 x 122.00	98 418 161 MG cr		45°	H	<b>VAG92444</b> ■ 56.00 x 8.00 x 13.04		
					<b>VAG92369</b> ■ 60.00 x 8.00 x 13.07		
					<b>VAG92445</b> ■ 60.00 x 8.00 x 13.04		

<b>BX411</b> Fibre Composite, 1400mm							<b>NPO68</b> 55.00x70.00x8.00mm FPM



BX411

<b>724</b>	<b>94.40</b>	<b>Diesel</b>				
<b>8140.43C Euro 2</b>	4 Cyl.	2798cc	<b>78kW (106)PS</b>	<b>Turbo Intercooled</b>	<b>TD14449</b>	<b>1336</b>

<b>TB558</b> 154x30 01/00→	<b>TBK102</b> 01/00→ Component No: TB558; AE1010GP		<b>KIT</b>		

 B x C x D				 E x F x G			
OE	MAT.						
<b>V91292</b> ■ 40.80 x 8.00 x 120.70	7 301 820 MB cr		30°	Y	H	<b>VAG92373</b> ■ 56.00 x 8.03 x 13.04	
<b>V91994</b> ■ 35.80 x 8.00 x 121.90	99 432 837 MD cr		45°			<b>VAG92444</b> ■ 56.00 x 8.00 x 13.04	
						<b>VAG92369</b> ■ 60.00 x 8.00 x 13.07	
						<b>VAG92445</b> ■ 60.00 x 8.00 x 13.04	

<b>BX391</b> Fibre Composite, 1200mm <b>BX401</b> Fibre Composite, 1300mm <b>BX411</b> Fibre Composite, 1400mm <b>BX421</b> Fibre Composite, 1500mm	<b>DX391</b> ▲	<b>GX390</b> ▲	<b>HBS011</b> ⊕ M12x1.25x119.00mm (x12)	<b>JC054</b> ■ <b>JC055</b> ■ JF123	<b>JN956</b>	<b>HR602</b> ■	<b>NPO67</b> ■ 50.00x70.00x10.00mm FPM



BX391



BX401



BX411



BX421

# FIAT GROUP

## 725

### 94.40

#### Diesel



8140.43K.4000 Euro 3 (D3)

4 Cyl.

18.5:1

2798cc

107kW (146)PS

Turbo Intercooled

TD17143

1337

 B x C x D			 MAT.			 30° Y H			 E x F x G		
<b>V91292</b> ■	7 301 820		30°	Y	H	<b>VAG92373</b> ■					
40.80 x 8.00 x 120.70		MB cr				56.00 x 8.03 x 13.04					
<b>V91994</b> ■	99 432 837		45°			<b>VAG92444</b> ■					
35.80 x 8.00 x 121.90		MD cr				56.00 x 8.00 x 13.04					
						<b>VAG92369</b> ■					
						60.00 x 8.00 x 13.07					
						<b>VAG92445</b> ■					
						60.00 x 8.00 x 13.04					

<b>BX401</b> Fibre Composite, 1300mm						<b>JC054</b> ■			<b>JN956</b>							<b>NP068</b>				
<b>BX411</b> Fibre Composite, 1400mm						<b>JC055</b> ■										55.00x70.00x8.00mm FPM				
<b>BX421</b> Fibre Composite, 1500mm																				
<b>BX401</b>	<b>BX411</b>	<b>BX421</b>																		

## 726

### 94.40

#### Diesel



8140.43N Euro 3 (D3)

4 Cyl.

18.5:1

2798cc

107kW (146)PS

Turbo Intercooled



TD20450

1340









 B x C x D			 MAT.			 30° Y H			 E x F x G		
<b>V91292</b> ■	7 301 820		30°	Y	H	<b>VAG92373</b> ■					
40.80 x 8.00 x 120.70		MB cr				56.00 x 8.03 x 13.04					
<b>V91994</b> ■	99 432 837		45°			<b>VAG92444</b> ■					
35.80 x 8.00 x 121.90		MD cr				56.00 x 8.00 x 13.04					
						<b>VAG92369</b> ■					
						60.00 x 8.00 x 13.07					
						<b>VAG92445</b> ■					
						60.00 x 8.00 x 13.04					

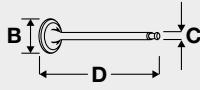
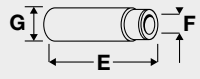













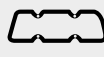

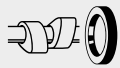
<b>BX391</b> Fibre Composite, 1200mm	<b>DX392</b> ▲	<b>GX392</b> ▲	<b>HBS255</b> ⊕	<b>JC055</b> ■	<b>JN956</b>	<b>HR602</b> ■	<b>NP068</b>													
<b>BX401</b> Fibre Composite, 1300mm			M12x1.25x160.00mm (x8)				55.00x70.00x8.00mm FPM													
<b>BX411</b> Fibre Composite, 1400mm																				
<b>BX421</b> Fibre Composite, 1500mm																				
<b>BX391</b>	<b>BX401</b>	<b>BX411</b>	<b>BX421</b>																	

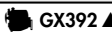



**727**  **94.40 Diesel** 











**8140.43N Euro 3 (D3)** 4 Cyl. 18.5:1 2798cc **107kW (146)PS** **Turbo Intercooled** **TD16873** **1339**

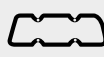

 B x C x D				 E x F x G			
OE	MAT.	Angle	Y	H			
<b>V91292</b> 	7 301 820		30°	Y	H	<b>VAG92373</b> 	
40.80 x 8.00 x 120.70		MB cr				56.00 x 8.03 x 13.04	
<b>V91994</b> 	99 432 837		45°			<b>VAG92444</b> 	
35.80 x 8.00 x 121.90		MD cr				56.00 x 8.00 x 13.04	
						<b>VAG92369</b> 	
						60.00 x 8.00 x 13.07	
						<b>VAG92445</b> 	
						60.00 x 8.00 x 13.04	

							
<b>BX391</b> Fibre Composite, 1200mm	<b>DX392</b> 	<b>GX392</b> 	<b>HBS011</b>  M12x1.25x119.00mm (x12)	<b>JC054</b>  <b>JC055</b> 	<b>JN956</b>	<b>HR602</b> 	<b>NPO68</b> 55.00x70.00x8.00mm FPM
<b>BX401</b> Fibre Composite, 1300mm							
<b>BX411</b> Fibre Composite, 1400mm							
<b>BX421</b> Fibre Composite, 1500mm							
							
<b>BX391</b>	<b>BX401</b>	<b>BX411</b>	<b>BX421</b>				









**728**  **94.40 Diesel** 

**8140.43P Euro 3 (D3)** 4 Cyl. 18.5:1 2798cc **78kW (106)PS** **Turbo Intercooled** **TD22680** **1330**

							
<b>BX401</b> Fibre Composite, 1300mm	<b>CH5242</b>			<b>JC055</b> 			
<b>BX411</b> Fibre Composite, 1400mm	MLS						
<b>BX421</b> Fibre Composite, 1500mm							
							
<b>BX401</b>	<b>BX411</b>	<b>BX421</b>					

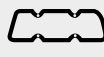
**729**  **94.40 Diesel** 

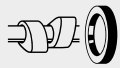
**8140.43R.4430 Euro 3 (D3)** 4 Cyl. 18.5:1 2798cc **66kW (90)PS** **Turbo Intercooled** **TD25994** **1332**

							
<b>BX411</b> Fibre Composite, 1400mm							<b>NPO68</b> 55.00x70.00x8.00mm FPM
							
<b>BX411</b>							

# FIAT GROUP

## 730



94.40

Diesel



8140.43R Euro 3 (D3)

4 Cyl.

18.5:1

2798cc

66kW (90)PS

Turbo Intercooled

TD18570

1341

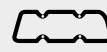

BX391 Fibre Composite, 1200mm  
 BX401 Fibre Composite, 1300mm  
 BX411 Fibre Composite, 1400mm  
 BX421 Fibre Composite, 1500mm

DX391 ▲

GX392 ▲

HB5011 ⊕  
 M12x1.25x119.00mm (x12)

JC054 ■  
 JC055 ■

JN956

HR602 ■

NP068  
 55.00x70.00x8.00mm FPM



BX391

BX401

BX411

BX421

## 731



94.40

Diesel



8140.43S

4 Cyl.

18.5:1

2798cc

94kW (128)PS

Turbo Intercooled

TD16196

1342



TB558  
 154x30  
 →03/01  
 TB368  
 152x30  
 03/01→07/06, HNBR

TBK102  
 →03/01  
 Component No: TB558;  
 AE1010GP  
 TBK037  
 03/01→07/06  
 Component No: TB368;  
 AE1011TP;AE1010GP

CAM681

FOL169 (x8) [6]

[6] Mechanical

[6] Mécanique

[6] Meccanico

[6] Mecánico

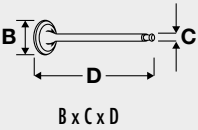

OE

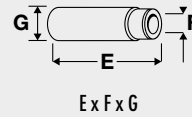

V91292 ■  
 40.80 x 8.00 x 120.70  
 V91994 ■  
 35.80 x 8.00 x 121.90

7 301 820  
 99 432 837

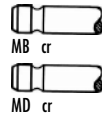

VAG92373 ■  
 56.00 x 8.03 x 13.04  
 VAG92444 ■  
 56.00 x 8.00 x 13.04  
 VAG92369 ■  
 60.00 x 8.00 x 13.07  
 VAG92445 ■  
 60.00 x 8.00 x 13.04

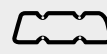
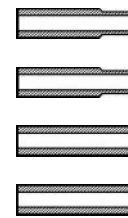

BX391 Fibre Composite, 1200mm  
 BX401 Fibre Composite, 1300mm  
 BX411 Fibre Composite, 1400mm  
 BX421 Fibre Composite, 1500mm

DX391 ▲  
 DX392 ▲

GX392 ▲

HB5255 ⊕  
 M12x1.25x160.00mm (x8)

JC054 ■ (x4)  
 JC055 ■ (x4)  
 JF123

JP069

HR602 ■

NP068  
 55.00x70.00x8.00mm FPM



BX391

BX401

BX411

BX421

<b>732</b>	<b>94.40</b>	<b>Diesel</b>					
<b>8140.43S Euro 3 (D3)</b>	4 Cyl.	18.5:1	2798cc	<b>92-100kW (125-136)PS</b>	<b>Turbo Intercooled</b>	<b>TD16874</b>	<b>1339</b>

B x C x D	OE	MAT.	30°	45°	H	E x F x G
<b>V91292</b> ■ 40.80 x 8.00 x 120.70	7 301 820	MB cr	30°	Y	H	<b>VAG92373</b> ■ 56.00 x 8.03 x 13.04
<b>V91994</b> ■ 35.80 x 8.00 x 121.90	99 432 837	MD cr	45°			<b>VAG92444</b> ■ 56.00 x 8.00 x 13.04
						<b>VAG92369</b> ■ 60.00 x 8.00 x 13.07
						<b>VAG92445</b> ■ 60.00 x 8.00 x 13.04

<b>BX391</b> Fibre Composite, 1200mm	<b>BX401</b> Fibre Composite, 1300mm	<b>BX411</b> Fibre Composite, 1400mm	<b>BX421</b> Fibre Composite, 1500mm	<b>DX391</b> ▲	<b>GX390</b> ▲	<b>HBS011</b> ◊ M12x1.25x119.00mm (x12)	<b>JC054</b> ■ <b>JC055</b> ■	<b>JN956</b>	<b>HR602</b> ■	<b>NPO68</b> 55.00x70.00x8.00mm FPM
<b>BX391</b>	<b>BX401</b>	<b>BX411</b>	<b>BX421</b>							

<b>733</b>	<b>94.40</b>	<b>Diesel</b>					
<b>8140.63.4000 Euro 3 (D3)</b>	4 Cyl.	21.7:1	2798cc	<b>62kW (84)PS</b>	<b>Turbo Intercooled</b>	<b>TD20478</b>	<b>1343</b>

B x C x D	OE	MAT.	30°	45°	H	E x F x G
<b>V91939</b> ■ 43.50 x 8.00 x 122.00	98 468 338	MB cr	30°		H	<b>VAG92373</b> ■ 56.00 x 8.03 x 13.04
<b>V91940</b> ■ 36.70 x 8.00 x 122.00	98 418 161	MG cr	45°		H	<b>VAG92444</b> ■ 56.00 x 8.00 x 13.04
						<b>VAG92369</b> ■ 60.00 x 8.00 x 13.07
						<b>VAG92445</b> ■ 60.00 x 8.00 x 13.04

<b>AY680</b> Fibre Composite, 1.600mm	<b>AY690</b> Fibre Composite, 1.700mm	<b>AY700</b> Fibre Composite, 1.800mm	<b>CY680</b> ▲	<b>FY690</b> ▲	<b>HBS255</b> ◊ M12x1.25x160.00mm (x8)	<b>JC054</b> ■ <b>JC055</b> ■	<b>JP069</b>	<b>HR602</b> ■
<b>AY680, AY690, AY700</b>								

# FIAT GROUP

## 734

94.40

Diesel



8140.63. Euro 2

4 Cyl.

21.7:1

2798cc

62kW (84)PS

TD10389

1343



CAM718

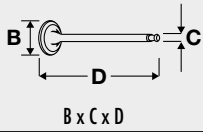

OE



MAT.



H

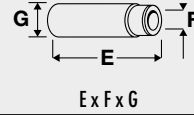

**V91939** ■  
43.50 x 8.00 x 122.00

98 468 338

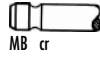

MB cr

30°

**V91940** ■  
36.70 x 8.00 x 122.00

98 418 161

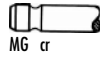

MG cr

45°

Eng. → 261347

**V91994** ■  
35.80 x 8.00 x 121.90

99 432 837

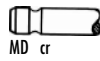

MD cr

45°

Eng. 261348 →

**VAG92373** ■  
56.00 x 8.03 x 13.04



**VAG92444** ■  
56.00 x 8.00 x 13.04



**VAG92369** ■  
60.00 x 8.00 x 13.07



**VAG92445** ■  
60.00 x 8.00 x 13.04

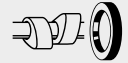
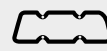

**AY680** Fibre Composite, 1.600mm

**CY680** ▲

**AY690** Fibre Composite, 1.700mm

**JC054** ■

**JC055** ■

**HR602** ■

**NP068**

55.00x70.00x8.00mm FPM

**AY700** Fibre Composite, 1.800mm



AY680, AY690, AY700

## 735

94.40

Diesel



8149.03.3971

4 Cyl.

2798cc

FM45739

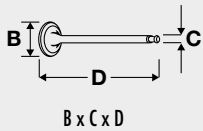

OE



MAT.



H

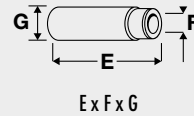

**V91939** ■  
43.50 x 8.00 x 122.00

98 468 338

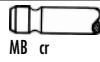

MB cr

30°

**V91940** ■  
36.70 x 8.00 x 122.00

98 418 161

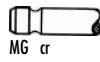

MG cr

45°

Eng. → 261347

**V91994** ■  
35.80 x 8.00 x 121.90

99 432 837

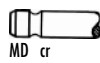

MD cr

45°

Eng. 261348 →

**VAG92444** ■  
56.00 x 8.00 x 13.04



**VAG92369** ■  
60.00 x 8.00 x 13.07



**VAG92373** ■  
56.00 x 8.03 x 13.04



**VAG92445** ■  
60.00 x 8.00 x 13.04

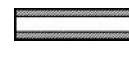

<b>736</b>	<b>94.40</b>	<b>Diesel</b>					
<b>8140.43</b>	4 Cyl.	18.5:1	2800cc	<b>90kW (122)PS</b>	<b>Turbocharged</b>	<b>TD11769</b>	<b>1344</b>

<b>TB558</b> 154x30	<b>TBK102</b> Component No: TB558; AE1010GP	<b>CAM681</b>	<b>KIT</b>	<b>FOL169 (x8) [6]</b>

[6] Mechanical      [6] Mécanique      [6] Meccanico      [6] Mecánico

B x C x D	OE	MAT.		Y	H	E x F x G
<b>V91292</b> ■ 40.80 x 8.00 x 120.70	7 301 820	 MB cr	30°			<b>VAG92193</b> ■ 56.00 x 8.04 x 13.05
<b>V91994</b> ■ 35.80 x 8.00 x 121.90	99 432 837	 MD cr	45°			<b>VAG92373</b> ■ 56.00 x 8.03 x 13.04
						<b>VAG92444</b> ■ 56.00 x 8.00 x 13.04
						<b>VAG92194</b> ■ 60.00 x 8.04 x 13.05
						<b>VAG92369</b> ■ 60.00 x 8.00 x 13.07
						<b>VAG92445</b> ■ 60.00 x 8.00 x 13.04

<b>BX391</b> Fibre Composite, 1200mm	<b>DX391</b> ▲	<b>GX410</b> ▲	<b>HBS255</b> ① M12x1.25x160.00mm (x8)	<b>JC054</b> ■ <b>JC055</b> ■ ② JF123	<b>JN956</b>	<b>HR602</b> ■	<b>NP068</b> 55.00x70.00x8.00mm FPM

<b>BX391</b>	<b>BX401</b>	<b>BX411</b>	<b>BX421</b>

# FIAT GROUP

## 737

### 94.40

### Diesel



8140.63      4 Cyl.      21:1      2800cc      64kW (87)PS      TD12749      1345

<b>TB701</b> 153x30 →11/01	<b>TBK039</b> →11/01 Component No: TB701; AE1010GP	<b>CAM718</b>			

	OE	MAT.				
B x C x D						E x F x G
<b>V91939</b>	98 468 338		30°		H	<b>VAG92193</b>
43.50 x 8.00 x 122.00		MB cr				56.00 x 8.04 x 13.05
<b>V91940</b>	98 418 161		45°		H	<b>VAG92373</b>
36.70 x 8.00 x 122.00		MG cr				56.00 x 8.03 x 13.04
<b>V91994</b>	99 432 837		45°			<b>VAG92444</b>
35.80 x 8.00 x 121.90		MD cr				56.00 x 8.00 x 13.04
						<b>VAG92194</b>
						60.00 x 8.04 x 13.05
						<b>VAG92369</b>
						60.00 x 8.00 x 13.07
						<b>VAG92445</b>
						60.00 x 8.00 x 13.04

<b>AY680</b> Fibre Composite, 1.600mm	<b>CY680</b>	<b>FY691</b>	<b>HBS255</b>	<b>JC054</b>	<b>JP069</b>	<b>HR602</b>	<b>NP068</b>
<b>AY690</b> Fibre Composite, 1.700mm			M12x1.25x160.00mm (x8)	<b>JC055</b>			55.00x70.00x8.00mm FPM
<b>AY700</b> Fibre Composite, 1.800mm							



AY680, AY690, AY700

## 738



### 95.00











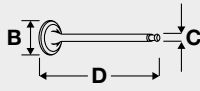
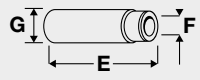

### Diesel





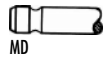







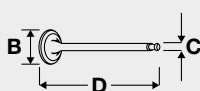
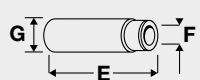

8025.01      2 Cyl.      17:1      1559cc      FM569      1346



	OE	MAT.				
B x C x D						E x F x G
<b>V91301</b>	4 803 805		30°			<b>VAG92444</b>
45.50 x 8.00 x 125.50		MD				56.00 x 8.00 x 13.04
01/84→						
<b>V91679</b>	353 722		30°		H	
45.50 x 8.00 x 125.50		MB				
01/84→						
<b>V91709</b>	4 802 200		45°		H	
44.00 x 8.00 x 125.50		MB				
<b>V91302</b>	4 806 718		45°			
37.50 x 8.00 x 125.50		MD cr				
01/84→						
<b>V91304</b>	99 432 718		45°		H	
37.50 x 8.00 x 125.50		ME cr				
01/84→						
<b>V91677</b>			45°			
37.00 x 8.00 x 125.50		MD				
<b>V91678</b>			45°		H	
37.00 x 8.00 x 125.50		MG				



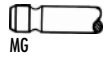





<b>739</b>	 <b>95.00</b>	<b>Diesel</b>			
803 A.062 (8030.01)	3 Cyl.	17:1	2339cc	FM570	<b>1346</b>
804A (8040.01)	4 Cyl.		3119cc	FM4009	<b>1346</b>

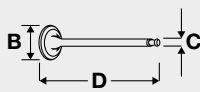
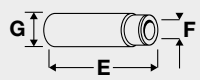

						
B x C x D	OE	MAT.				Ex F x G
<b>V91676</b> 	4 659 379		45°		H	<b>VAG92444</b> 
44.00 x 8.00 x 125.50		MB				56.00 x 8.00 x 13.04
<b>V91677</b> 			45°			<b>VAG92497</b> 
37.00 x 8.00 x 125.50		MD				56.00 x 8.04 x 14.03
<b>V91678</b> 			45°		H	
37.00 x 8.00 x 125.50		MG				

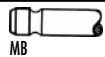

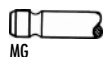



<b>740</b>	 <b>95.00</b>	<b>Diesel</b>				
8030.00	3 Cyl.	17:1	2340cc	<b>28-38kW (38-51)PS</b>	TD22232	<b>1348</b>



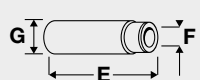



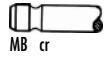

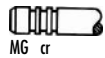
						
B x C x D	OE	MAT.				Ex F x G
<b>V91709</b> 	4 802 200		45°		H	<b>VAG92444</b> 
44.00 x 8.00 x 125.50		MB				56.00 x 8.00 x 13.04
<b>V91667</b> 	4 673 608		45°		H	<b>VAG92497</b> 
37.00 x 8.00 x 125.70		MG				56.00 x 8.04 x 14.03

<b>741</b>	 <b>95.00</b>	<b>Diesel</b>				
8040.00	4 Cyl.	17:1	3120cc	<b>51kW (70)PS</b>	TD24575	<b>1350</b>

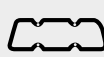

						
B x C x D	OE	MAT.				Ex F x G
<b>V91676</b> 	4 659 379		45°		H	<b>VAG92444</b> 
44.00 x 8.00 x 125.50		MB				56.00 x 8.00 x 13.04
<b>V91667</b> 	4 673 608		45°		H	<b>VAG92497</b> 
37.00 x 8.00 x 125.70		MG				56.00 x 8.04 x 14.03



<b>742</b>	 <b>95.80</b>	<b>Diesel</b>					
F1CE0481A	4 Cyl.	19:1	2998cc	<b>100-114kW (136-155)PS</b>	Turbo Intercooled	TD19195	<b>1352</b>
F1CE0481B Euro 3 (D3)	4 Cyl.	19:1	2998cc	<b>122kW (166)PS</b>	Turbo Intercooled	TD22675	<b>1352</b>







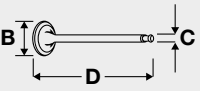
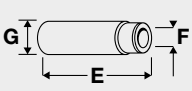



						
B x C x D	OE	MAT.				Ex F x G
<b>V98042</b> 	504 072 531		30°			
32.40 x 5.99 x 119.90		MB cr				
<b>V98043</b> 	504 081 062		30°			
32.40 x 5.98 x 119.90		MG cr				

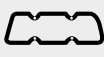

							
	CG7300 ▲			JD5981 			
				Soft Material Gasket			









# FIAT GROUP



<b>743</b>	 <b>95.80</b>	<b>Diesel</b>				
<b>F1CE0481FA Euro 4 (D4)</b>	4 Cyl.	2998cc	<b>107kW (146)PS</b>	<b>Turbo Intercooled</b>	<b>TD19224</b>	<b>1352</b>
<b>F1CE0481HA EEV</b>	4 Cyl.	2998cc	<b>125-130kW (170-177)PS</b>	<b>Turbo Intercooled</b>	<b>TD19225</b>	<b>1354</b>
<b>F1CE0481HC Euro 4 (D4)</b>	4 Cyl.	2998cc	<b>130kW (176)PS</b>	<b>Turbo Intercooled</b>	<b>TD19230</b>	<b>1354</b>

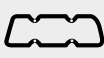







	
B x C x D	E x F x G
OE	
MAT.	
<b>V98042</b> 	30°
504 072 531	
32.40 x 5.99 x 119.90	
<b>V98043</b> 	30°
504 081 062	
32.40 x 5.98 x 119.90	

						
<b>AG6050</b> MLS, 1.100mm	<b>CG7300</b> ▲	<b>HBS464</b> ☉	<b>JD5981</b> 	Soft Material Gasket		
<b>AG6060</b> MLS, 1.200mm		M15x1.50x193.00mm (x6)				
<b>AG7300</b> MLS, 1.300mm						
						
<b>AG6050</b>	<b>AG6060</b>	<b>AG7300</b>				

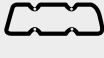

<b>744</b>	 <b>95.80</b>	<b>Diesel</b>				
<b>F1CE3481LC EEV</b>	4 Cyl.	19:1	<b>2998cc</b>	<b>103kW (140)PS</b>	<b>Turbo Intercooled</b>	<b>TD24072</b>









						
			<b>JD5981</b> 	Soft Material Gasket		

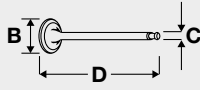



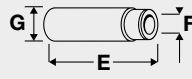





<b>745</b>	 <b>95.80</b>	<b>Petrol</b>				
<b>F1CE0441A</b>	4 Cyl.	12.5:1	<b>2999cc</b>	<b>100kW (136)PS</b>		<b>TD24770</b>

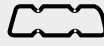

						
			<b>JD5981</b> 	Soft Material Gasket		











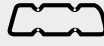

<b>746</b>	 <b>95.80</b>	<b>Diesel</b>					
<b>F1CE0481D Euro 4 (D4)</b>	4 Cyl.	19:1	2999cc	<b>115-116kW (156-158)PS</b>	<b>Turbo Intercooled</b>	<b>TD20265</b>	<b>1353</b>

					
B x C x D	OE	MAT.			E x F x G
<b>V98042</b> 	504 072 531		30°		
32.40 x 5.99 x 119.90		MB cr			
<b>V98043</b> 	504 081 062		30°		
32.40 x 5.98 x 119.90		MG cr			

							
<b>AG6050</b> MLS, 1.100mm	<b>CG7300</b> ▲			<b>JD5981</b> 			
<b>AG6060</b> MLS, 1.200mm				Soft Material Gasket			
<b>AG7300</b> MLS, 1.300mm							
							
<b>AG6050</b>	<b>AG6060</b>	<b>AG7300</b>					

<b>747</b>	 <b>95.80</b>	<b>Diesel</b>					
<b>F1CE3481E Euro 5</b>	4 Cyl.	17.5:1	2999cc	<b>130kW (177)PS</b>	<b>Turbo Intercooled</b>	<b>TD25176</b>	
<b>F1CE3481M Euro 5</b>	4 Cyl.	17.5:1	2999cc	<b>115kW (156)PS</b>	<b>Turbo Intercooled</b>	<b>TD24897</b>	
<b>F1CE3481N Euro 5</b>	4 Cyl.	17.5:1	2999cc	<b>107kW (146)PS</b>	<b>Turbo Intercooled</b>	<b>TD24896</b>	

							
<b>AG6050</b> MLS, 1.100mm	<b>CG7300</b> ▲			<b>JD5981</b> 			
<b>AG6060</b> MLS, 1.200mm				Soft Material Gasket			
<b>AG7300</b> MLS, 1.300mm							
							
<b>AG6050</b>	<b>AG6060</b>	<b>AG7300</b>					



# BOTTOM ENGINE APPLICATIONS

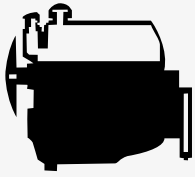

MOTORBLOCKANWENDUNGEN

APPLICAZIONI PARTE BASSA DEL MOTORE

APPLICATIONS BAS MOTEUR

APLICACIONES PARA LA PARTE INFERIOR DEL MOTOR

DÓŁ SILNIKA

ДЕТАЛИ НИЖНЕЙ ЧАСТИ ДВИГАТЕЛЯ

تطبيقات المحرك السفلية



 **GLYCO**<sup>®</sup>



 **GOETZE**<sup>®</sup>



**Niral**<sup>®</sup>  
FITTED WITH  **GOETZE**<sup>®</sup> RINGS



 **Payen**<sup>®</sup>

# FIAT GROUP

<b>748</b>	<b>65.00</b>	<b>Petrol</b>	
<b>141 A4.000</b>	4 Cyl.	10.5:1	769cc
			<b>25kW (34)PS</b>
			<b>TD931</b>
<b>141 A4.048</b>	4 Cyl.	9.3:1	770cc
			<b>25kW (34)PS</b>
			<b>TD930</b>

BE/PL	4	39.985/40.005	43.657/43.670	16.550	1.813	0.026/0.084	AL-LF	3025RA	<b>01-4139/4</b> STD 0.25 0.50
MB/HL 1,3	2	50.785/50.805	54.507/54.520	20.620	1.837	0.028/0.086	AL-LF	62006RA	<b>H1039/3</b> STD 0.25 0.50
MB/HL 2	1	50.790/50.810	54.507/54.520	22.780	1.837	0.028/0.086	AL-LF	62007RA	
TW/A	2	54.610/54.864	69.596/69.850		2.362		AL-LF	2897AFF	<b>A182/2</b> STD

<b>749</b>	<b>65.00</b>	<b>Petrol</b>	
<b>141 B.000</b>	4 Cyl.	9.2:1	769cc
			<b>25kW (34)PS</b>
			<b>TD4370</b>
			<b>1</b>

<b>87-209800-30</b> <b>87-209806-30</b>	STD 0.40mm	<b>08-209800-00</b> <b>08-209806-00</b> <b>08-209808-00</b>	STD 0.40mm 0.60mm
<b>A</b> 36.80 <b>D</b> 61.80 20x54		1.75 CR P 2.00 P 3.95 P	<b>14-011001-00 D</b> B 68.04 C 115.00 

BE/PL	4	39.985/40.005	43.657/43.670	16.550	1.813	0.026/0.084	AL-LF	3025RA	<b>01-4139/4</b> STD 0.25 0.50
MB/HL 1,3	2	50.785/50.805	54.507/54.520	20.620	1.837	0.028/0.086	AL-LF	62006RA	<b>H1039/3</b> STD 0.25 0.50
MB/HL 2	1	50.790/50.810	54.507/54.520	22.780	1.837	0.028/0.086	AL-LF	62007RA	
TW/A	2	54.610/54.864	69.596/69.850		2.362		AL-LF	2897AFF	<b>A182/2</b> STD

	<b>JJ449</b>	<b>NA5049</b> 64.00x80.00x8.00mm, ACM
	<b>JJ449</b>	

<b>750</b>	<b>65.00</b>	<b>Petrol</b>				
<b>156 A4.000</b>	4 Cyl.	9.4:1	770cc	<b>25kW (34)PS</b>	<b>TD11307</b>	<b>2</b>
<b>156 A4.048</b>	4 Cyl.	9.4:1	770cc	<b>25kW (34)PS</b>	<b>TD11308</b>	<b>3</b>

<b>87-782700-00</b> <b>87-782708-00</b>  STD 0.60mm  <b>A</b> 37.55 <b>B+</b> 0.80 <b>D</b> 63.35 18x53	<b>08-782700-00</b> STD  1.50  CR P 1.50  P 3.00  CR [15]	<b>14-011001-00 D</b> <b>B</b> 68.04 <b>C</b> 115.00  	









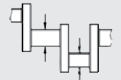

[15] Steel                      [15] Acier                      [15] Acciaio                      [15] Acero

BE/PL	MB/HL 3	MB/HL 1-5	MB/HL 1-5	MB/HL 3						
4	2	5	9	1						
37.998/38.008	48.000/48.100	43.990/44.000	43.990/44.000	43.990/44.000						
41.128/41.140	63.800/64.000	47.705/47.718	47.705/47.718	47.705/47.718						
19.000	2.325	19.000	19.000	23.910						
1.549		1.841	1.848	1.848						
0.022/0.069		0.023/0.081	0.020/0.057	0.020/0.057						
AL-LF	AL-LF	AL-LF	AL-LF	AL-LF						
1015RA	04-4075	1016RA	4271RA	4272RAH						
<b>01-4116/4</b> STD 0.25 0.50	<b>H1067/5</b> STD 0.25 0.50		<b>H1091/5</b> STD							







<b>EP280</b>		<b>NB815</b> 23.00x35.00x7.00mm, FPM <b>NB814</b> 70.00x88.00x8.00mm, FPM



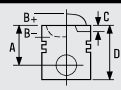
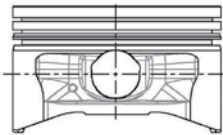
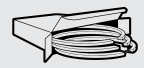





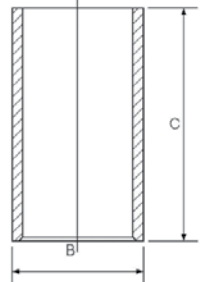

<b>751</b>	<b>65.00</b>	<b>Petrol</b>				
<b>100 G.000</b>	4 Cyl.	8:1	843cc	<b>25kW (34)PS</b>	<b>TD863</b>	<b>4</b>
<b>100 GL.048</b>	4 Cyl.	7.8:1	903cc	<b>29kW (40)PS</b>	<b>TD4413</b>	<b>9</b>
<b>146 A.048</b>	4 Cyl.	9:1	903cc	<b>33kW (45)PS</b>	<b>TD934</b>	<b>12</b>

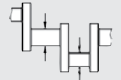

<b>87-209800-00</b> <b>87-209806-00</b> <b>87-209808-00</b>  STD 0.40mm 0.60mm  <b>A</b> 30.75 <b>D</b> 61.25 20x54	<b>08-209800-00</b> STD <b>08-209806-00</b> 0.40mm <b>08-209808-00</b> 0.60mm  1.75  CR P 2.00  P 3.95  P	<b>14-011001-00 D</b> <b>B</b> 68.04 <b>C</b> 115.00  	

<b>751</b>		 <b>65.00</b>	<b>Petrol</b>						
									
BE/PL	4	39.985/40.005	43.657/43.670	16.550	1.813	0.026/0.084	AL-LF	3025RA	<b>01-4139/4</b> STD 0.25 0.50
MB/HL 1,3	2	50.785/50.805	54.507/54.520	20.620	1.837	0.028/0.086	AL-LF	62006RA	<b>H1039/3</b> STD 0.25 0.50
MB/HL 2	1	50.790/50.810	54.507/54.520	22.780	1.837	0.028/0.086	AL-LF	62007RA	
TW/A	2	54.610/54.864	69.596/69.850		2.362		AL-LF	2897AFF	<b>A182/2</b> STD

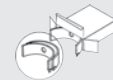
<b>752</b>		 <b>65.00</b>	<b>Petrol</b>						
<b>100 G.002</b>	4 Cyl.	8.8:1	843cc	<b>27kW (37)PS</b>				<b>TD864</b>	<b>4</b>
<b>100 GC.000</b>	4 Cyl.	9.3:1	843cc	<b>38kW (52)PS</b>				<b>TD868</b>	<b>4</b>

				
<b>87-209800-00</b> STD <b>87-209806-00</b> 0.40mm <b>87-209808-00</b> 0.60mm  <b>A</b> 30.75 <b>D</b> 61.25  20x54	<b>08-209800-00</b> STD <b>08-209806-00</b> 0.40mm <b>08-209808-00</b> 0.60mm  1.75  CR P 2.00  P 3.95  P	<b>14-011001-00 D</b> <b>B</b> 68.04 <b>C</b> 115.00  		



									
BE/PL	4	39.985/40.005	43.657/43.670	16.550	1.813	0.026/0.084	AL-LF	3025RA	<b>01-4139/4</b> STD 0.25 0.50
MB/HL 1,3	2	50.785/50.805	54.507/54.520	20.620	1.837	0.028/0.086	AL-LF	62006RA	<b>H1039/3</b> STD 0.25 0.50
MB/HL 2	1	50.790/50.810	54.507/54.520	22.780	1.837	0.028/0.086	AL-LF	62007RA	
TW/A	2	54.610/54.864	69.596/69.850		2.362		AL-LF	2897AFF	<b>A182/2</b> STD







		
---	---	---



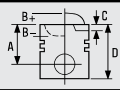
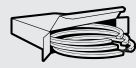





HC027 



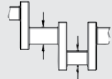
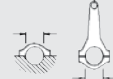

HC027

<b>753</b>	 <b>65.00</b>	<b>Petrol</b>	
<b>100 GB.000</b>	4 Cyl.	8.8:1	843cc
			<b>35kW (47)PS</b>
			<b>TD865</b>
			<b>4</b>

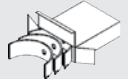
			
	<b>08-209800-00</b> STD <b>08-209806-00</b> 0.40mm <b>08-209808-00</b> 0.60mm  1.75  CR P 2.00  P 3.95  P		



									
BE/PL	4	39.985/40.005	43.657/43.670	16.550	1.813	0.026/0.084	AL-LF	3025RA	<b>01-4139/4</b> STD 0.25 0.50
MB/HL 1,3	2	50.785/50.805	54.507/54.520	20.620	1.837	0.028/0.086	AL-LF	62006RA	<b>H1039/3</b> STD 0.25 0.50
MB/HL 2	1	50.790/50.810	54.507/54.520	22.780	1.837	0.028/0.086	AL-LF	62007RA	
TW/A	2	54.610/54.864	69.596/69.850		2.362		AL-LF	2897AFF	<b>A182/2</b> STD







		
---	---	---



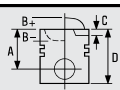
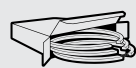





HC027 

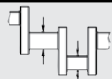

HC027

<b>754</b>	 <b>65.00</b>	<b>Petrol</b>	
<b>100 GBS.000</b>	4 Cyl.		903cc
			<b>38kW (52)PS</b>
			<b>TD867</b>
			<b>7</b>
<b>100 GL.064</b>	4 Cyl.	9:1	903cc
			<b>33kW (45)PS</b>
			<b>TD23116</b>
<b>100 GL6.000</b>	4 Cyl.	8:1	843cc
			<b>25kW (34)PS</b>
			<b>TD21449</b>
<b>M020 AA.09.0</b>	4 Cyl.	9:1	903cc
			<b>33kW (45)PS</b>
			<b>TD22241</b>

			
	<b>08-209800-00</b> STD <b>08-209806-00</b> 0.40mm <b>08-209808-00</b> 0.60mm  1.75  CR P 2.00  P 3.95  P		

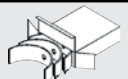
									
BE/PL	4	39.985/40.005	43.657/43.670	16.550	1.813	0.026/0.084	AL-LF	3025RA	<b>01-4139/4</b> STD 0.25 0.50
MB/HL 1,3	2	50.785/50.805	54.507/54.520	20.620	1.837	0.028/0.086	AL-LF	62006RA	<b>H1039/3</b> STD 0.25 0.50
MB/HL 2	1	50.790/50.810	54.507/54.520	22.780	1.837	0.028/0.086	AL-LF	62007RA	
TW/A	2	54.610/54.864	69.596/69.850		2.362		AL-LF	2897AFF	<b>A182/2</b> STD

# FIAT GROUP

<b>755</b>	<b>65.00</b>	<b>Petrol</b>	
<b>1170 A1.000</b>	4 Cyl.	899cc	<b>29-30kW (40-41)PS</b>
			<b>TD1030</b> <b>5</b>

	<b>08-209800-00</b> STD <b>08-209806-00</b> 0.40mm <b>08-209808-00</b> 0.60mm  1.75  CR P 2.00  P 3.95  P		

BE/PL	MB/HL 1,3	MB/HL 2	TW/A						
4	2	1	2						
39.985/40.005	50.785/50.805	50.790/50.810	54.610/54.864						
43.657/43.670	54.507/54.520	54.507/54.520	69.596/69.850						
16.550	20.620	22.780							
1.813	1.837	1.837	2.362						
0.026/0.084	0.028/0.086	0.028/0.086							
AL-LF	AL-LF	AL-LF	AL-LF						
3025RA	62006RA	62007RA	2897AFF						











	JJ605	<b>NA5177</b> 42.00x56.00x7.00mm, FPM <b>NB808</b> 64.00x80.00x8.00mm, FPM
	JJ605	

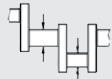





<b>756</b>	<b>65.00</b>	<b>Petrol</b>	
<b>1170 A1.046</b>	4 Cyl.	8.8:1 899cc	<b>29kW (39)PS</b>
			<b>TD872</b> <b>6</b>

<b>87-145100-00</b> STD <b>87-145106-00</b> 0.40mm <b>87-145108-00</b> 0.60mm  A 31.25 D 54.25 20x54	<b>08-145100-00</b> STD <b>08-145106-00</b> 0.40mm <b>08-145108-00</b> 0.60mm  1.50  NT 1.50  P 3.00  P  <b>08-145100-10</b> STD  1.50  P 1.50  P 3.00  P	<b>14-011001-00 D</b> B 68.04 C 115.00  	











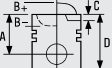
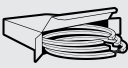





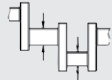
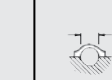

...Continued

<b>756</b>		 <b>65.00</b>		<b>Petrol</b>						
										
BE/PL	4	39.985/40.005	43.657/43.670	16.550	1.813	0.026/0.084	AL-LF	3025RA	<b>01-4139/4</b> STD 0.25 0.50	
MB/HL 1,3	2	50.785/50.805	54.507/54.520	20.620	1.837	0.028/0.086	AL-LF	62006RA	<b>H1039/3</b> STD 0.25 0.50	
MB/HL 2	1	50.790/50.810	54.507/54.520	22.780	1.837	0.028/0.086	AL-LF	62007RA		
TW/A	2	54.610/54.864	69.596/69.850		2.362		AL-LF	2897AFF	<b>A182/2</b> STD	

		
	JJ605	<b>NA5177</b>  42.00x56.00x7.00mm, FPM <b>NB808</b>  64.00x80.00x8.00mm, FPM
		
	JJ605	

<b>757</b>		 <b>65.00</b>		<b>Petrol</b>					
<b>100 GBC.000</b>	4 Cyl.	9.5:1	903cc	<b>38kW (52)PS</b>		<b>TD866</b>		<b>7</b>	
<b>100 GBC.040</b>	4 Cyl.	9.5:1	903cc	<b>38kW (52)PS</b>		<b>TD23115</b>			

			
	<b>08-209800-00</b> STD <b>08-209806-00</b> 0.40mm <b>08-209808-00</b> 0.60mm  1.75  CR P 2.00  P 3.95  P		

										
BE/PL	4	39.985/40.005	43.657/43.670	16.550	1.813	0.026/0.084	AL-LF	3025RA	<b>01-4139/4</b> STD 0.25 0.50	
TW/A	2	54.610/54.864	69.596/69.850		2.362		AL-LF	2897AFF	<b>A182/2</b> STD	

# FIAT GROUP

<b>758</b>	<b>65.00</b>	<b>Petrol</b>			
<b>100 GF 000</b>	4 Cyl.	7.8:1	903cc	<b>26kW (35)PS</b>	<b>TD6939 8</b>
<b>100 GL.000</b>	4 Cyl.	9:1	903cc	<b>30-33kW (41-45)PS</b>	<b>TD870 8</b>



<b>87-209800-00</b> STD <b>87-209806-00</b> 0.40mm <b>87-209808-00</b> 0.60mm  <b>A</b> 30.75 <b>D</b> 61.25 20x54	<b>08-209800-00</b> STD <b>08-209806-00</b> 0.40mm <b>08-209808-00</b> 0.60mm  1.75  CR P 2.00  P 3.95  P	<b>14-011001-00 D</b> <b>B</b> 68.04 <b>C</b> 115.00  	







BE/PL	4	39.985/40.005	43.657/43.670	16.550	1.813	0.026/0.084	AL-LF	3025RA	<b>01-4139/4</b> STD 0.25 0.50
MB/HL 1,3	2	50.785/50.805	54.507/54.520	20.620	1.837	0.028/0.086	AL-LF	62006RA	<b>H1039/3</b> STD 0.25 0.50
MB/HL 2	1	50.790/50.810	54.507/54.520	22.780	1.837	0.028/0.086	AL-LF	62007RA	
TW/A	2	54.610/54.864	69.596/69.850		2.362		AL-LF	2897AFF	<b>A182/2</b> STD



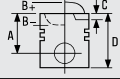
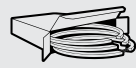



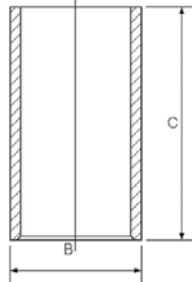

			<b>HC027</b>				<b>NA5049</b> 64.00x80.00x8.00mm, ACM <b>NB808</b> 64.00x80.00x8.00mm, FPM			
			<b>HC027</b>							



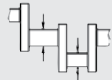
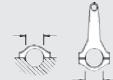



<b>759</b>	<b>65.00</b>	<b>Petrol</b>			
<b>100 GL.040</b>	4 Cyl.	7.8:1	903cc	<b>38kW (52)PS</b>	<b>TD22509</b>

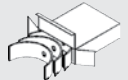

BE/PL	4	39.985/40.005	43.657/43.670	16.550	1.813	0.026/0.084	AL-LF	3025RA	<b>01-4139/4</b> STD 0.25 0.50
TW/A	2	54.610/54.864	69.596/69.850		2.362		AL-LF	2897AFF	<b>A182/2</b> STD

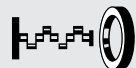

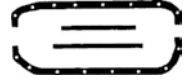



**760**  **65.00** **Petrol**   
**100 GL3.000** **4 Cyl.** **9:1** **903cc** **33kW (45)PS** **TD869** **10**

			
<b>87-209800-00</b> STD <b>87-209806-00</b> 0.40mm <b>87-209808-00</b> 0.60mm  <b>A</b> 30.75 <b>D</b> 61.25  20x54	<b>08-209800-00</b> STD <b>08-209806-00</b> 0.40mm <b>08-209808-00</b> 0.60mm  <b>1.75</b>  CR P <b>2.00</b>  P <b>3.95</b>  P	<b>14-011001-00 D</b> <b>B 68.04 C 115.00</b>  	

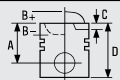
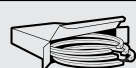
									
BE/PL	4	39.985/40.005	43.657/43.670	16.550	1.813	0.026/0.084	AL-LF	3025RA	<b>01-4139/4</b> STD 0.25 0.50
MB/HL 1,3	2	50.785/50.805	54.507/54.520	20.620	1.837	0.028/0.086	AL-LF	62006RA	<b>H1039/3</b> STD 0.25 0.50
MB/HL 2	1	50.790/50.810	54.507/54.520	22.780	1.837	0.028/0.086	AL-LF	62007RA	
TW/A	2	54.610/54.864	69.596/69.850		2.362		AL-LF	2897AFF	<b>A182/2</b> STD

		
	<b>HC027</b>  → Eng.8064870   <b>HC027</b>	<b>NA5049</b>  64.00x80.00x8.00mm, ACM <b>NB808</b>  64.00x80.00x8.00mm, FPM

**761**  **65.00** **Petrol**   
**146 A.000** **4 Cyl.** **9:1** **903cc** **33kW (45)PS** **TD4371** **11**

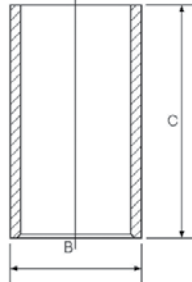
			
<b>87-209800-10</b> [17] STD <b>87-209806-10</b> [17] 0.40mm <b>87-209808-10</b> [17] 0.60mm  <b>A</b> 31.25 <b>D</b> 61.75  20x54	<b>08-209800-00</b> STD <b>08-209806-00</b> 0.40mm <b>08-209808-00</b> 0.60mm  <b>1.75</b>  CR P <b>2.00</b>  P <b>3.95</b>  P	<b>14-011001-00 D</b> <b>B 68.04 C 115.00</b>  	









[17] Without circlips

[17] Sans circlips

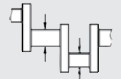
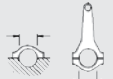
[17] Pistone con spinotto montato a caldo



[17] Sin anillos de retención

### 761 65.00 Petrol

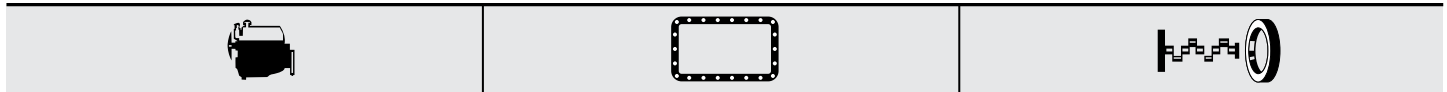
									
BE/PL	4	39.985/40.005	43.657/43.670	16.550	1.813	0.026/0.084	AL-LF	3025RA	<b>01-4139/4</b> STD 0.25 0.50
MB/HL 1,3	2	50.785/50.805	54.507/54.520	20.620	1.837	0.028/0.086	AL-LF	62006RA	<b>H1039/3</b> STD 0.25 0.50
MB/HL 2	1	50.790/50.810	54.507/54.520	22.780	1.837	0.028/0.086	AL-LF	62007RA	
TW/A	2	54.610/54.864	69.596/69.850		2.362		AL-LF	2897AFF	<b>A182/2</b> STD



**HC027**   
→Eng.8064870









**NA5049**  64.00x80.00x8.00mm, ACM  
**NB808**  64.00x80.00x8.00mm, FPM

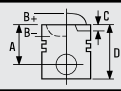
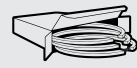

HC027

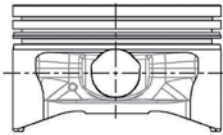
### 762 65.00 Petrol

146 A1.000 4 Cyl. 9:1 903cc 33kW (45)PS TD4372 13

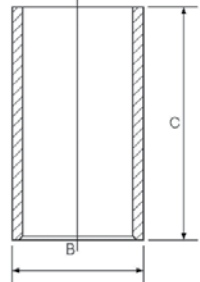







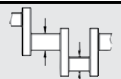

			
<p><b>87-209800-10</b> [17] STD</p> <p><b>87-209806-10</b> [17] 0.40mm</p> <p><b>87-209808-10</b> [17] 0.60mm</p> <p>A 31.25 D 61.75  20x54</p> 	<p><b>08-209800-00</b> STD</p> <p><b>08-209806-00</b> 0.40mm</p> <p><b>08-209808-00</b> 0.60mm</p> <p>1.75  CR P</p> <p>2.00  P</p> <p>3.95  P</p>	<p><b>14-011001-00 D</b></p> <p>B 68.04 C 115.00</p> 	

[17] Without circlips

[17] Sans circlips



[17] Pistone con spinotto montato a caldo

[17] Sin anillos de retención

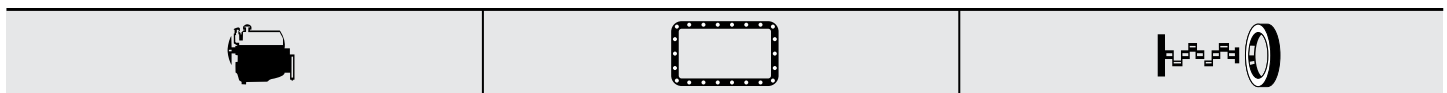
									
BE/PL	4	39.985/40.005	43.657/43.670	16.550	1.813	0.026/0.084	AL-LF	3025RA	<b>01-4139/4</b> STD 0.25 0.50
TW/A	2	54.610/54.864	69.596/69.850		2.362		AL-LF	2897AFF	<b>A182/2</b> STD



**HC027**   
→Eng.8064870

**NA5049**  64.00x80.00x8.00mm, ACM  
**NB808**  64.00x80.00x8.00mm, FPM



HC027

<b>763</b>	<b>65.00</b>	<b>Petrol</b>				
<b>170 A1.000</b>	4 Cyl.	8.8:1	903cc	<b>30kW (41)PS</b>	<b>TD15810</b>	<b>14</b>
<b>170 A1.046</b>	4 Cyl.	8.8:1	903cc	<b>30kW (41)PS</b>	<b>TD15811</b>	<b>15</b>

<b>87-145100-00</b> STD <b>87-145106-00</b> 0.40mm <b>87-145108-00</b> 0.60mm  <b>A</b> 31.25 <b>D</b> 54.25 20x54		<b>08-145100-00</b> STD <b>08-145106-00</b> 0.40mm <b>08-145108-00</b> 0.60mm  1.50  NT 1.50  P 3.00  P	<b>14-011001-00 D</b> <b>B 68.04 C 115.00</b>  
	<b>08-145100-10</b> STD  1.50  P 1.50  P 3.00  P		

BE/PL	4	39.985/40.005	43.657/43.670	16.550	1.813	0.026/0.084	AL-LF	3025RA	<b>01-4139/4</b> STD 0.25 0.50
MB/HL 1,3	2	50.785/50.805	54.507/54.520	20.620	1.837	0.028/0.086	AL-LF	62006RA	<b>H1039/3</b> STD 0.25 0.50
MB/HL 2	1	50.790/50.810	54.507/54.520	22.780	1.837	0.028/0.086	AL-LF	62007RA	
TW/A	2	54.610/54.864	69.596/69.850		2.362		AL-LF	2897AFF	<b>A182/2</b> STD

	<b>JJ449</b> →02/98 <b>JJ605</b> 03/98→	<b>NA5177</b> 42.00x56.00x7.00mm, FPM <b>NB808</b> 64.00x80.00x8.00mm, FPM

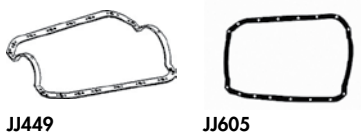

JJ449 JJ605

# FIAT GROUP

<b>764</b>	<b>65.00</b>	<b>Petrol</b>							
<b>903</b>	4 Cyl.	903cc	<b>33kW (45)PS</b>	<b>TD6824</b>	<b>7</b>				

BE/PL	4	49.984/50.000	53.695/53.708	20.050	1.830	0.040/0.090	AL-LF	66725RA	<b>01-4200/4</b> STD 0.30 0.50
MB/HL 1-5	5	59.981/60.000	63.731/63.750	20.290	1.845	0.040/0.100	AL-LF	66726RA	<b>H1057/5</b> STD 0.30 0.50
TW/A	4	67.050/67.300	83.050/83.300		2.330		BS	66721BF	<b>A214/4</b> STD 0.10
SE/PB	1	25.007/25.020	27.200/27.221	24.050			BS	66729YA	<b>55-4201</b> SEMI
SE/PB	1	25.007/25.020	27.000/27.021	24.150			BS	66729Y	<b>55-4266</b> STD

66729YA

66729Y

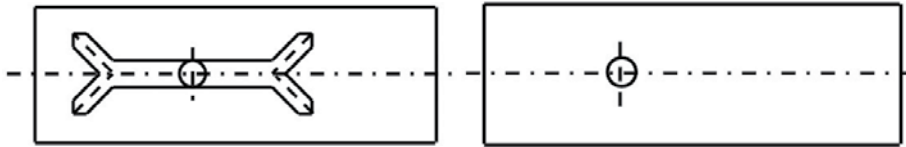

<b>765</b>	<b>65.00</b>	<b>Petrol</b>							
<b>A112 A.000</b>	4 Cyl.	9:1	903cc	<b>21-32kW (29-44)PS</b>	<b>TD1856</b>	<b>16</b>			
<b>A112 B2.000</b>	4 Cyl.	9:1	903cc	<b>29-32kW (40-44)PS</b>	<b>TD4622</b>	<b>17</b>			

<b>87-209800-00</b> <b>87-209806-00</b> <b>87-209808-00</b>	STD 0.40mm 0.60mm		<b>08-209800-00</b> <b>08-209806-00</b> <b>08-209808-00</b>	STD 0.40mm 0.60mm		<b>14-011001-00 D</b> B 68.04 C 115.00	
<b>A</b> 30.75 <b>D</b> 61.25 			1.75 2.00 3.95		CR P P P		
<b>87-209800-10 [17]</b> <b>87-209806-10 [17]</b> <b>87-209808-10 [17]</b>	STD 0.40mm 0.60mm		<b>08-209800-00</b> <b>08-209806-00</b> <b>08-209808-00</b>	STD 0.40mm 0.60mm			
<b>A</b> 31.25 <b>D</b> 61.75 			1.75 2.00 3.95		CR P P P		











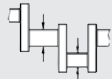
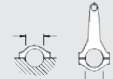

[17] Without circlips





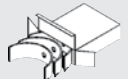

[17] Sans circlips



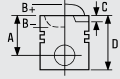
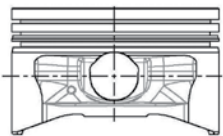
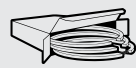

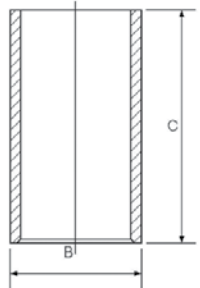





[17] Pistone con spinotto montato a caldo

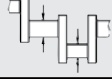
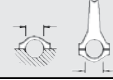

[17] Sin anillos de retención

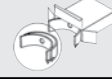
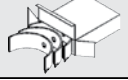
...Continued









<b>765</b>		 <b>65.00</b>		<b>Petrol</b>					
									
BE/PL	4	39.985/40.005	43.657/43.670	16.550	1.813	0.026/0.084	AL-LF	3025RA	<b>01-4139/4</b> STD 0.25 0.50
MB/HL 1,3	2	50.785/50.805	54.507/54.520	20.620	1.837	0.028/0.086	AL-LF	62006RA	<b>H1039/3</b> STD 0.25 0.50
MB/HL 2	1	50.790/50.810	54.507/54.520	22.780	1.837	0.028/0.086	AL-LF	62007RA	
TW/A	2	54.610/54.864	69.596/69.850		2.362		AL-LF	2897AFF	<b>A182/2</b> STD
									
						<b>NB808</b>  64.00x80.00x8.00mm, FPM			

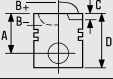



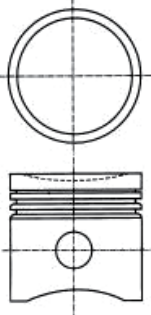
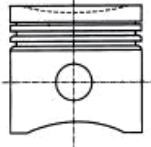

<b>766</b>		 <b>65.00</b>		<b>Petrol</b>					
<b>A112 A5.000</b>		4 Cyl.	9:1	903cc	<b>29-31kW (40-42)PS</b>		<b>TD1803</b>		<b>16</b>
									
<b>87-209800-00</b>	STD	<b>08-209800-00</b>	STD	<b>14-011001-00 D</b>					
<b>87-209806-00</b>	0.40mm	<b>08-209806-00</b>	0.40mm	<b>B 68.04</b>	<b>C 115.00</b>				
<b>87-209808-00</b>	0.60mm	<b>08-209808-00</b>	0.60mm						
<b>A</b> 30.75		1.75		CR P					
<b>D</b> 61.25		2.00		P					
 20x54		3.95		P					

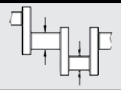
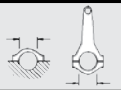

<b>766</b>		 <b>65.00</b>		<b>Petrol</b>					
									
BE/PL	4	39.985/40.005	43.657/43.670	16.550	1.813	0.026/0.084	AL-LF	3025RA	<b>01-4139/4</b> STD 0.25 0.50
MB/HL 1,3	2	50.785/50.805	54.507/54.520	20.620	1.837	0.028/0.086	AL-LF	62006RA	<b>H1039/3</b> STD 0.25 0.50
MB/HL 2	1	50.790/50.810	54.507/54.520	22.780	1.837	0.028/0.086	AL-LF	62007RA	
TW/A	2	54.610/54.864	69.596/69.850		2.362		AL-LF	2897AFF	<b>A182/2</b> STD
									
						<b>NB808</b>  64.00x80.00x8.00mm, FPM			

**767**  **67.20** **Petrol** 

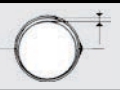

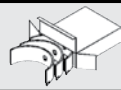



**A112 A2.000** 4 Cyl. 10.2:1 1050cc **51kW (69)PS** **TD4621** **18**



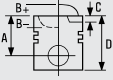
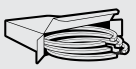



			
<b>87-782606-00</b> 0.40mm <b>87-782608-00</b> 0.60mm  <b>A</b> 30.75 <b>B-</b> 1.50 <b>D</b> 54.75  18x56	  	<b>08-782600-00</b> STD <b>08-782606-00</b> 0.40mm <b>08-782608-00</b> 0.60mm  1.50  CR P 1.75  P 3.95  CR [15]	
[15] Steel	[15] Acier	[15] Acciaio	[15] Acero

									
BE/PL	4	39.985/40.005	43.657/43.670	16.550	1.813	0.026/0.084	AL-LF	3025RA	<b>01-4139/4</b> STD 0.25 0.50
MB/HL 1,3	2	53.910/53.930	57.548/57.561	20.620	1.797		AL-LF	66446RA	<b>H1178/3</b> STD 0.25
MB/HL 2	1	53.910/53.930	57.548/57.561	21.340	1.797		AL-LF	66447RA	
TW/A	2	59.436/59.960	72.771/73.025		2.320		AL-LF	66447BF	<b>A206/2</b> STD

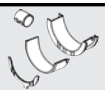

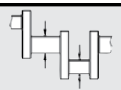
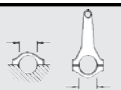
**768**  **67.20** **Petrol** 

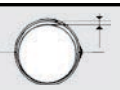

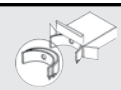
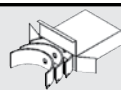



**A 112 AB.2C.0** 4 Cyl. 10.2:1 1050cc **51kW (70)PS** **TD22321**

			
	<b>08-782600-00</b> STD <b>08-782606-00</b> 0.40mm <b>08-782608-00</b> 0.60mm  1.50  CR P 1.75  P 3.95  CR [15]		
[15] Steel	[15] Acier	[15] Acciaio	[15] Acero

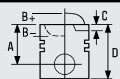
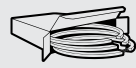





									
BE/PL	4	39.985/40.005	43.657/43.670	16.550	1.813	0.026/0.084	AL-LF	3025RA	<b>01-4139/4</b> STD 0.25 0.50
MB/HL 1,3	2	53.910/53.930	57.548/57.561	20.620	1.797		AL-LF	66446RA	<b>H1178/3</b> STD 0.25
MB/HL 2	1	53.910/53.930	57.548/57.561	21.340	1.797		AL-LF	66447RA	
TW/A	2	59.436/59.960	72.771/73.025		2.320		AL-LF	66447BF	<b>A206/2</b> STD





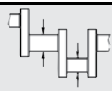
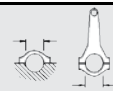

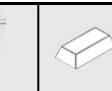

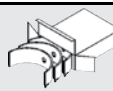

**769**  **67.20** **Petrol**   
**A112 B1.000** 4 Cyl. 9.2:1 965cc **35kW (48)PS** **TD1824** **19**

			
	<b>08-782600-00</b> STD <b>08-782606-00</b> 0.40mm <b>08-782608-00</b> 0.60mm  1.50  CR P 1.75  P 3.95  CR [15]		

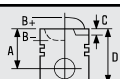
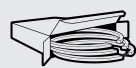



[15] Steel [15] Acier [15] Acciaio [15] Acero



										
BE/PL 4	MB/HL 1,3 2	MB/HL 2 1	TW/A 2	39.985/40.005	43.657/43.670	16.550	1.813	0.026/0.084	AL-LF 3025RA	<b>01-4139/4</b> STD 0.25 0.50
				50.785/50.805	54.507/54.520	20.620	1.837	0.028/0.086	AL-LF 62006RA	<b>H1039/3</b> STD 0.25 0.50
				50.790/50.810	54.507/54.520	22.780	1.837	0.028/0.086	AL-LF 62007RA	
				54.610/54.864	69.596/69.850		2.362		AL-LF 2897AFF	<b>A182/2</b> STD

**770**  **67.20** **Petrol**   
**A 112 B1.054** 4 Cyl. 9.2:1 965cc **35-36kW (48-49)PS** **TD4412** **20**

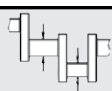
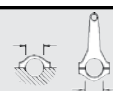
			
	<b>08-782600-00</b> STD <b>08-782606-00</b> 0.40mm <b>08-782608-00</b> 0.60mm  1.50  CR P 1.75  P 3.95  CR [15]		

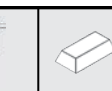
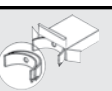
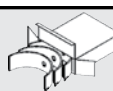
[15] Steel [15] Acier [15] Acciaio [15] Acero

										
BE/PL 4	MB/HL 1,3 2	MB/HL 2 1	TW/A 2	39.985/40.005	43.657/43.670	16.550	1.813	0.026/0.084	AL-LF 3025RA	<b>01-4139/4</b> STD 0.25 0.50
				50.785/50.805	54.507/54.520	20.620	1.837	0.028/0.086	AL-LF 62006RA	<b>H1039/3</b> STD 0.25 0.50
				50.790/50.810	54.507/54.520	22.780	1.837	0.028/0.086	AL-LF 62007RA	
				54.610/54.864	69.596/69.850		2.362		AL-LF 2897AFF	<b>A182/2</b> STD



		
---	---	---

**HC027**   
 →Eng.8064870









**NA5049**  64.00x80.00x8.00mm, ACM

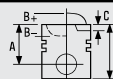
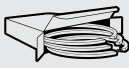

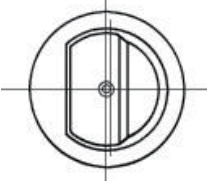

**HC027**

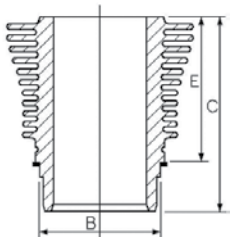

**771**  **67.40** **Petrol** 

**110 D.000**    2 Cyl.    7:1    499cc    **13kW (18)PS**    **TD23456**

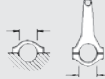
				
<p><b>87-528300-00</b>    STD <b>87-528306-00</b>    0.40mm</p> <p><b>A</b>    39.80 <b>B+</b>    4.00 <b>D</b>    72.30</p> <p> 20x58</p>	 	<p><b>08-528300-00</b>    STD <b>08-528306-00</b>    0.40mm</p> <p>2.00  CR P 2.00  P 3.50  P</p>	<p>[10]    <b>B</b> 75.00    <b>C</b> 130.00    <b>E</b> 90.00</p> 	<p><b>88-528300-00</b></p>







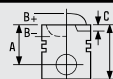
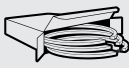

[10] Liner available in Kit Set only    [10] Chemise disponible en kit seulement    [10] Cilindro disponibile solo in kit motore    [10] Camisas disponible en conjuntos solamente.

									
BE/PL	2	44.013/44.033	47.130/47.142	19.200	1.543	0.011/0.068	AL-LF	60005RA	<b>01-4112/2</b> STD 0.25 0.50 <b>55-4210</b> SEMI
SE/PB	1	19.507/19.609	22.009/22.034	20.830			BS	60009X	

**772**  **67.40** **Petrol** 

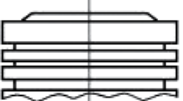
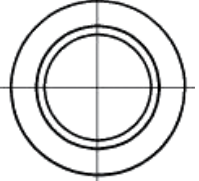
**110 F.000**    2 Cyl.    7.1:1    499cc    **13kW (18)PS**    **TD871**    **21**



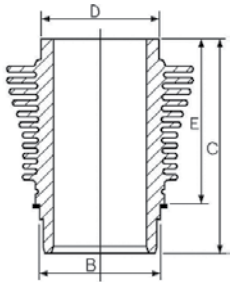



**120.000**    2 Cyl.       499cc    **13kW (18)PS**    **TD873**    **21**









				
<p><b>87-527600-00</b>    STD <b>87-527606-00</b>    0.40mm <b>87-527608-00</b>    0.60mm</p> <p><b>A</b>    37.95 <b>B+</b>    2.75 <b>D</b>    74.70</p> <p> 20x55</p>	 	<p><b>08-527600-00</b>    STD <b>08-527606-00</b>    0.40mm <b>08-527608-00</b>    0.60mm</p> <p>2.00  CR P 2.00  P 2.00  P 3.96  P</p>	<p>[10]    <b>B</b> 75.00    <b>C</b> 130.90    <b>E</b> 89.90</p> 	<p><b>88-527600-00</b></p>



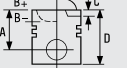
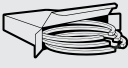





[10] Liner available in Kit Set only    [10] Chemise disponible en kit seulement    [10] Cilindro disponibile solo in kit motore    [10] Camisas disponible en conjuntos solamente.



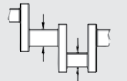

									
BE/PL	2	44.013/44.033	47.130/47.142	19.200	1.543	0.011/0.068	AL-LF	60005RA	<b>01-4112/2</b> STD 0.25 0.50 <b>55-4210</b> SEMI
SE/PB	1	19.507/19.609	22.009/22.034	20.830			BS	60009X	



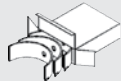



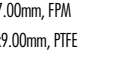

...Continued











<b>772</b>	 <b>67.40</b>	<b>Petrol</b>
		
	<b>JH310</b> 	<b>NA5045</b>  53.00x68.00x10.00mm, ACM
	<b>JH310</b>	

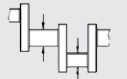



<b>773</b>	 <b>69.60</b>	<b>Diesel</b>				
<b>169 A1.000</b>	4 Cyl.	17.6:1	1248cc	<b>55kW (75)PS</b>	<b>TD20236</b>	<b>22</b>
						
	<b>08-137600-00</b> STD <b>08-137606-00</b> 0.40mm					
	2.00  CK P 1.50  P 2.00  P					

									
BE/PL	4	42.582/42.600	45.734/45.744	20.000	1.552	0.030/0.062	BS	71-4033	<b>71-4033/4</b> STD .010
MB/HL 1,2,4,5	4	50.982/51.000	54.710/54.722	19.000	1.840	0.026/0.050	AL-LF	02-4034	<b>H1011/5</b> STD 0.25
MB/HL 3	1	50.982/51.000	54.710/54.722	23.950	1.840	0.026/0.050	AL-LF	02-4035H	
SE/PB	1	23.000	25.747/25.772	25.000			BS-LF	55-4077	<b>55-4077</b> SEMI













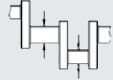
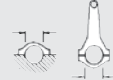

		
<b>ED5810</b>	<b>HR397</b>	<b>NA5223</b>  40.00x52.00x7.00mm, FPM <b>NA5230</b>  78.00x100.00x9.00mm, PTFE



<b>774</b>	 <b>69.60</b>	<b>Diesel</b>					
<b>169 A5.000</b>	4 Cyl.	16.8:1	1248cc	<b>55kW (75)PS</b>	<b>Turbo Intercooled</b>	<b>TD24712</b>	<b>23</b>
							
	<b>08-137600-00</b> STD <b>08-137606-00</b> 0.40mm						
	2.00  CK P 1.50  P 2.00  P						

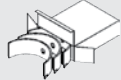









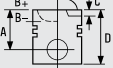
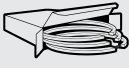

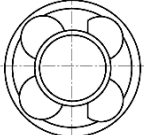
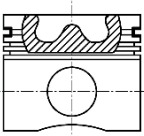



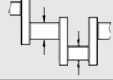
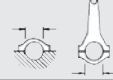

									
BE/PL	4	42.582/42.600	45.734/45.744	20.000	1.552	0.030/0.062	BS	71-4033	<b>71-4033/4</b> STD .010
MB/HL 1,2,4,5	4	50.982/51.000	54.710/54.722	19.000	1.840	0.026/0.050	AL-LF	02-4034	<b>H1011/5</b> STD 0.25
MB/HL 3	1	50.982/51.000	54.710/54.722	23.950	1.840	0.026/0.050	AL-LF	02-4035H	
SE/PB	1	23.000	25.747/25.772	25.000			BS-LF	55-4077	<b>55-4077</b> SEMI



		
		<b>NA5057</b>  27.00x37.00x7.00mm, FPM <b>NA5061</b>  74.00x88.00x8.00mm, FPM







# FIAT GROUP



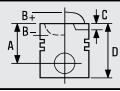
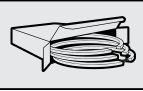

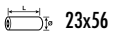
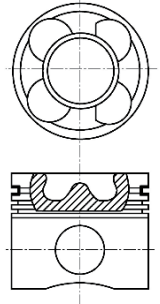

<b>775</b>		 <b>69.60</b>		<b>Diesel</b>						
<b>169 A5.000</b>		4 Cyl.	16.8:1	1248cc	<b>55kW (75)PS</b>		<b>Turbo Intercooled</b>		<b>TD24711</b>	<b>24</b>
										
BE/PL	4	42.582/42.600	45.734/45.744	20.000	1.552	0.030/0.062	BS	71-4033	<b>71-4033/4</b> STD .010	
MB/HL 1,2,4,5	4	50.982/51.000	54.710/54.722	19.000	1.840	0.026/0.050	AL-LF	02-4034	<b>H1011/5</b> STD 0.25	
MB/HL 3	1	50.982/51.000	54.710/54.722	23.950	1.840	0.026/0.050	AL-LF	02-4035H		
SE/PB	1	23.000	25.747/25.772	25.000			BS-LF	55-4077	<b>55-4077</b> SEMI	
			<b>HR397</b>			<b>NA5223</b>  40.00x52.00x7.00mm, FPM <b>NA5230</b>  78.00x100.00x9.00mm, PTFE				



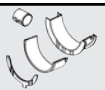

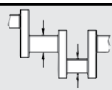
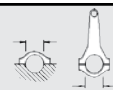
<b>776</b>		 <b>69.60</b>		<b>Diesel</b>						
<b>188 A8.000</b>		4 Cyl.	18:1	1248cc	<b>51kW (70)PS</b>		<b>Turbo Intercooled</b>		<b>TD23866</b>	<b>25</b>
<b>188 A9.000</b>		4 Cyl.	18:1	1248cc	<b>51-55kW (70-75)PS</b>		<b>Turbo Intercooled</b>		<b>TD17456</b>	<b>22</b>
<b>188 A9.000</b>		4 Cyl.	18:1	1248cc	<b>51kW (70)PS</b>				<b>TD18314</b>	<b>22</b>

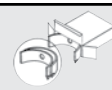
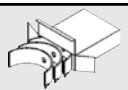

										
<b>87-137600-00</b>	STD				<b>08-137600-00</b>	STD				
<b>87-137606-00</b>	0.40mm				<b>08-137606-00</b>	0.40mm				
<b>A</b>	40.43				<b>2.00</b>		<b>CK P</b>			
<b>B-</b>	12.40				<b>1.50</b>		<b>P</b>			
<b>BØ</b>	37.00				<b>2.00</b>		<b>P</b>			
<b>C</b>	1.20									
<b>D</b>	63.43									
	23x56									
<b>AK RT TP</b>										
										
BE/PL	4	42.582/42.600	45.734/45.744	20.000	1.552	0.030/0.062	BS	71-4033	<b>71-4033/4</b> STD .010	
MB/HL 1,2,4,5	4	50.982/51.000	54.710/54.722	19.000	1.840	0.026/0.050	AL-LF	02-4034	<b>H1011/5</b> STD 0.25	
MB/HL 3	1	50.982/51.000	54.710/54.722	23.950	1.840	0.026/0.050	AL-LF	02-4035H		
SE/PB	1	23.000	25.747/25.772	25.000			BS-LF	55-4077	<b>55-4077</b> SEMI	
			<b>HR397</b>			<b>NA5223</b>  40.00x52.00x7.00mm, FPM <b>NA5230</b>  78.00x100.00x9.00mm, PTFE				







<b>777</b>	 <b>69.60</b>	<b>Diesel</b>					
<b>199 A2.000</b>	4 Cyl.	18:1	1248cc	<b>55-56kW (75-76)PS</b>	<b>Turbo Intercooled</b>	<b>TD20240</b>	<b>22</b>
<b>199 A2.000</b>	4 Cyl.	18:1	1248cc	<b>55kW (75)PS</b>	<b>Turbo Intercooled</b>	<b>TD20272</b>	<b>26</b>



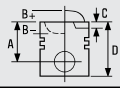
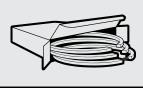

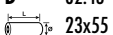
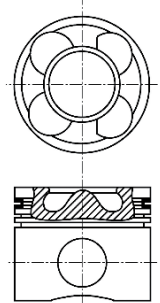



			
<b>87-137600-00</b> <b>87-137606-00</b> STD 0.40mm  <b>A</b> 40.43 <b>B-</b> 12.40 <b>BØ</b> 37.00 <b>C</b> 1.20 <b>D</b> 63.43  23x56	 <b>08-137600-00</b> STD <b>08-137606-00</b> 0.40mm  2.00  CK P 1.50  P 2.00  P		

									
BE/PL	4	42.582/42.600	45.734/45.744	20.000	1.552	0.030/0.062	BS	71-4033	<b>71-4033/4</b> STD .010
MB/HL 1,2,4,5	4	50.982/51.000	54.710/54.722	19.000	1.840	0.026/0.050	AL-LF	02-4034	<b>H1011/5</b> STD 0.25
MB/HL 3	1	50.982/51.000	54.710/54.722	23.950	1.840	0.026/0.050	AL-LF	02-4035H	
SE/PB	1	23.000	25.747/25.772	25.000			BS-LF	55-4077	<b>55-4077</b> SEMI

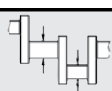
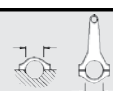
		
<b>ED5810</b>	<b>HR397</b>	<b>NA5223</b>  40.00x52.00x7.00mm, FPM <b>NA5230</b>  78.00x100.00x9.00mm, PTFE





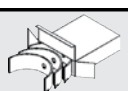

<b>778</b>	 <b>69.60</b>	<b>Diesel</b>					
<b>199 A3.000</b>	4 Cyl.	18:1	1248cc	<b>66-70kW (90-95)PS</b>	<b>Turbo Intercooled</b>	<b>TD20241</b>	<b>28</b>
<b>199 A3.000</b>	4 Cyl.	18:1	1248cc	<b>66-77kW (90-105)PS</b>	<b>Turbo Intercooled</b>	<b>TD20273</b>	<b>29</b>



			
<b>87-425600-00</b> <b>87-425606-00</b> STD 0.40mm  <b>A</b> 40.43 <b>B-</b> 12.41 <b>BØ</b> 38.00 <b>C</b> 0.91 <b>C</b> 0.91 <b>D</b> 62.43  23x55	 <b>08-425600-00</b> STD <b>08-425606-00</b> 0.40mm <b>08-425608-00</b> 0.60mm  2.00  CK P 1.50  NT 2.00  CR P		

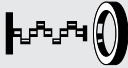







									
BE/PL	4	42.582/42.600	45.734/45.744	20.000	1.552	0.030/0.062	BS	71-4033	<b>71-4033/4</b> STD .010
MB/HL 1,2,4,5	4	50.982/51.000	54.710/54.722	19.000	1.840	0.026/0.050	AL-LF	02-4034	<b>H1011/5</b> STD 0.25
MB/HL 3	1	50.982/51.000	54.710/54.722	23.950	1.840	0.026/0.050	AL-LF	02-4035H	
SE/PB	1	23.000	25.747/25.772	25.000			BS-LF	55-4077	<b>55-4077</b> SEMI

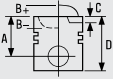







# FIAT GROUP



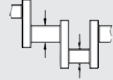



...Continued

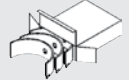

<b>778</b>	 <b>69.60</b>	<b>Diesel</b>
		
 ED5820	HR397	<b>NA5223</b>  40.00x52.00x7.00mm, FPM <b>NA5230</b>  78.00x100.00x9.00mm, PTFE

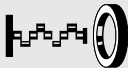





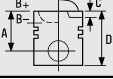

<b>779</b>	 <b>69.60</b>	<b>Diesel</b>					
<b>199 A3.000</b>	4 Cyl.	18:1	1248cc	<b>66kW (90)PS</b>	<b>Turbo Intercooled</b>	<b>TD23450</b>	<b>27</b>

			
	<b>08-435700-00</b> STD <b>08-435706-00</b> 0.40mm  1.50  GDC P 1.50  P 2.00  CR P  <b>GDC</b>  <b>LKZ-Ring</b> 		













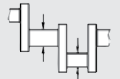
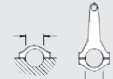

									
BE/PL	4	42.582/42.600	45.734/45.744	20.000	1.552	0.030/0.062	BS	71-4033	<b>71-4033/4</b> STD .010
MB/HL 1,2,4,5	4	50.982/51.000	54.710/54.722	19.000	1.840	0.026/0.050	AL-LF	02-4034	<b>H1011/5</b> STD 0.25
MB/HL 3	1	50.982/51.000	54.710/54.722	23.950	1.840	0.026/0.050	AL-LF	02-4035H	
SE/PB	1	23.000	25.747/25.772	25.000			BS-LF	55-4077	<b>55-4077</b> SEMI











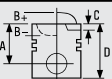













		
 ED5820	HR397	<b>NA5223</b>  40.00x52.00x7.00mm, FPM <b>NA5230</b>  78.00x100.00x9.00mm, PTFE



<b>780</b>	 <b>69.60</b>	<b>Diesel</b>					
<b>199 A9.000 Euro 5</b>	4 Cyl.	17.6:1	1248cc	<b>55kW (75)PS</b>	<b>Turbo Intercooled</b>	<b>TD23573</b>	<b>30</b>
<b>199 B1.000 Euro 5</b>	4 Cyl.	16.8:1	1248cc	<b>70kW (95)PS</b>	<b>Turbo Intercooled</b>	<b>TD23574</b>	<b>30</b>
<b>199 B1.000 Euro 5</b>	4 Cyl.	16.8:1	1248cc	<b>70kW (95)PS</b>	<b>Turbo Intercooled</b>	<b>TD24590</b>	<b>30</b>
<b>199 B2.000 Euro 5</b>	4 Cyl.	17.6:1	1248cc	<b>51kW (69)PS</b>	<b>Turbo Intercooled</b>	<b>TD23578</b>	<b>25</b>









			
	<b>08-435700-00</b> STD <b>08-435706-00</b> 0.40mm  1.50  GDC P 1.50  P 2.00  CR P  <b>GDC</b>  <b>LKZ-Ring</b> 		

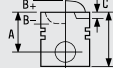
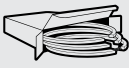





...Continued



<b>780</b>		 <b>69.60</b>		<b>Diesel</b>						
										
BE/PL	4	42.582/42.600	45.734/45.744	20.000	1.552	0.030/0.062	BS	71-4033	<b>71-4033/4</b> STD .010	
MB/HL 1,2,4,5	4	50.982/51.000	54.710/54.722	19.000	1.840	0.026/0.050	AL-LF	02-4034	<b>H1011/5</b> STD 0.25	
MB/HL 3	1	50.982/51.000	54.710/54.722	23.950	1.840	0.026/0.050	AL-LF	02-4035H		
SE/PB	1	23.000	25.747/25.772	25.000			BS-LF	55-4077	<b>55-4077</b> SEMI	
										
ED5810			HR397				NA5223  40.00x52.00x7.00mm, FPM NA5230  78.00x100.00x9.00mm, PTFE			











<b>781</b>		 <b>69.60</b>		<b>Diesel</b>							
<b>199 B1.000 Euro 5</b>		<b>4 Cyl.</b>	<b>16.8:1</b>	<b>1248cc</b>	<b>70kW (95)PS</b>		<b>Turbo Intercooled</b>		<b>TD24672 30</b>		
											
			<b>08-435700-00</b> STD <b>08-435706-00</b> 0.40mm  1.50  GDC P 1.50  P 2.00  CR P								
											
											
BE/PL	4	42.582/42.600	45.734/45.744	20.000	1.552	0.030/0.062	BS	71-4033	<b>71-4033/4</b> STD .010		
MB/HL 1,2,4,5	4	50.982/51.000	54.710/54.722	19.000	1.840	0.026/0.050	AL-LF	02-4034	<b>H1011/5</b> STD 0.25		
MB/HL 3	1	50.982/51.000	54.710/54.722	23.950	1.840	0.026/0.050	AL-LF	02-4035H			
SE/PB	1	23.000	25.747/25.772	25.000			BS-LF	55-4077	<b>55-4077</b> SEMI		
											
ED5800			HR397				NA5223  40.00x52.00x7.00mm, FPM NA5230  78.00x100.00x9.00mm, PTFE				

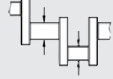



<b>782</b>	 <b>69.60</b>	<b>Diesel</b>					
<b>199 B4.000 Euro 5</b>	4 Cyl.	16.8:1	1248cc	<b>62kW (84)PS</b>	<b>Turbo Intercooled</b>	<b>TD24938</b>	<b>31</b>
<b>199 B4.000 Euro5/Euro6</b>	4 Cyl.	16.8:1	1248cc	<b>62kW (84)PS</b>	<b>Turbo Intercooled</b>	<b>TD24898</b>	<b>32</b>



			
	<b>08-435700-00</b> STD <b>08-435706-00</b> 0.40mm  1.50  GDC P 1.50  P 2.00  CR P		
 			

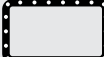



		
 <b>ED5820</b>	<b>HR397</b>	<b>NA5223</b>  40.00x52.00x7.00mm, FPM <b>NA5230</b>  78.00x100.00x9.00mm, PTFE

<b>783</b>	 <b>69.60</b>	<b>Diesel</b>					
<b>223 A9.000</b>	4 Cyl.	17.6:1	1248cc	<b>62kW (84)PS</b>	<b>Turbo Intercooled</b>	<b>TD20243</b>	<b>33</b>

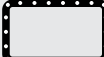

									
BE/PL	4	42.582/42.600	45.734/45.744	20.000	1.552	0.030/0.062	BS	71-4033	<b>71-4033/4</b> STD .010 <b>H1011/5</b> STD 0.25  <b>55-4077</b> SEMI
MB/HL 1,2,4,5	4	50.982/51.000	54.710/54.722	19.000	1.840	0.026/0.050	AL-LF	02-4034	
MB/HL 3	1	50.982/51.000	54.710/54.722	23.950	1.840	0.026/0.050	AL-LF	02-4035H	
SE/PB	1	23.000	25.747/25.772	25.000			BS-LF	55-4077	







		
 <b>ED5820</b>	<b>HR397</b>	<b>NA5223</b>  40.00x52.00x7.00mm, FPM <b>NA5230</b>  78.00x100.00x9.00mm, PTFE

<b>784</b>	 <b>69.60</b>	<b>Diesel</b>					
<b>263 A2.000</b>	4 Cyl.	16.8:1	1248cc	<b>66kW (90)PS</b>	<b>Turbo Intercooled</b>	<b>TD24796</b>	<b>32</b>

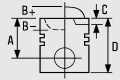
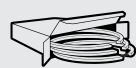

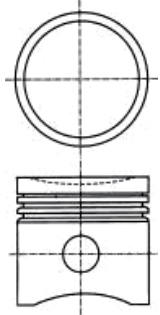
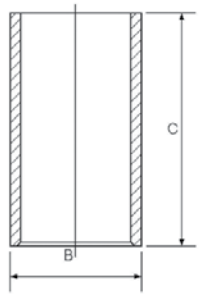
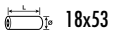





		
 <b>ED5820</b>	<b>HR397</b>	<b>NA5223</b>  40.00x52.00x7.00mm, FPM <b>NA5230</b>  78.00x100.00x9.00mm, PTFE



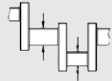
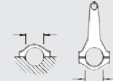



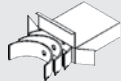

<b>785</b>		 <b>70.00</b>		<b>Petrol</b>			
<b>156 A2.246</b>	4 Cyl.	9.5:1	999cc	<b>33kW (45)PS</b>		<b>TD5423</b>	<b>35</b>
<b>156 A2.246</b>	4 Cyl.	9.5:1	999cc	<b>33kW (45)PS</b>		<b>TD994</b>	<b>36</b>
<b>156 C.000</b>	4 Cyl.	9:1	1108cc	<b>42kW (57)PS</b>		<b>TD1854</b>	<b>35</b>
<b>156 C.046</b>	4 Cyl.	9.6:1	1108cc	<b>37-43kW (50-58)PS</b>		<b>TD4389</b>	<b>37</b>
<b>156 C.046</b>	4 Cyl.	9:1	1108cc	<b>37-40kW (50-54)PS</b>		<b>TD4597</b>	<b>35</b>







							
<b>87-154200-10</b> <b>87-154206-10</b> <b>87-154208-10</b>	STD 0.40mm 0.60mm		<b>08-154200-00</b> <b>08-154206-00</b> <b>08-154208-00</b>	STD 0.40mm 0.60mm	<b>14-010991-00 D</b> <b>B 73.02 C 116.00</b>		
<b>A</b> 33.90 <b>B-</b> 1.50 <b>D</b> 57.40  18x53			1.50  <b>CR P</b> 1.50  <b>P</b> 3.00  <b>CR [15]</b>				

[15] Steel                      [15] Acier                      [15] Acciaio                      [15] Acero

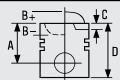
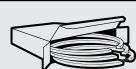
									
BE/PL	4	37.998/38.008	41.128/41.140	19.000	1.549	0.022/0.069	AL-LF	1015RA	<b>01-4116/4</b> STD 0.25 0.50
MB/HL 3	2	48.000/48.100	63.800/64.000		2.325		AL-LF	04-4075	<b>H1067/5</b> STD 0.25 0.50
MB/HL 1-5	5	43.990/44.000	47.705/47.718	19.000	1.841	0.023/0.081	AL-LF	1016RA	
MB/HL 1-5	9	43.990/44.000	47.705/47.718	19.000	1.848	0.020/0.057	AL-LF	4271RA	<b>H1091/5</b> STD
MB/HL 3	1	43.990/44.000	47.705/47.718	23.910	1.848	0.020/0.057	AL-LF	4272RAH	

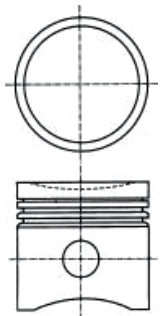
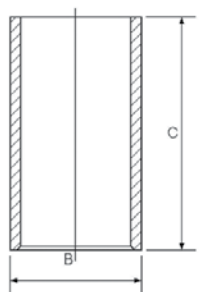
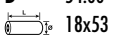
		
<b>EP280</b>	<b>HR397</b>	<b>NB815</b>  23.00x35.00x7.00mm, FPM <b>NB814</b>  70.00x88.00x8.00mm, FPM











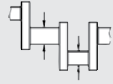

<b>786</b>		 <b>70.00</b>		<b>Petrol</b>			
<b>160 A3.000</b>	4 Cyl.	9.6:1	1108cc	<b>41-42kW (56-57)PS</b>		<b>TD10189</b>	<b>37</b>

							
<b>87-154200-30</b> <b>87-154206-30</b> <b>87-154208-30</b>	STD 0.40mm 0.60mm		<b>08-154200-00</b> <b>08-154206-00</b> <b>08-154208-00</b>	STD 0.40mm 0.60mm	<b>14-010991-00 D</b> <b>B 73.02 C 116.00</b>		
<b>A</b> 30.00 <b>B-</b> 1.80 <b>D</b> 54.00  18x53			1.50  <b>CR P</b> 1.50  <b>P</b> 3.00  <b>CR [15]</b>				



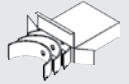

[15] Steel                      [15] Acier                      [15] Acciaio                      [15] Acero





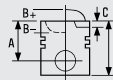
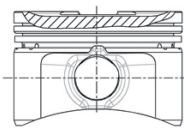
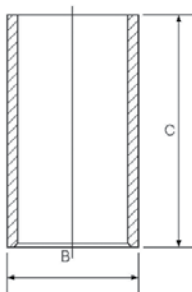



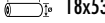



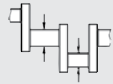

# FIAT GROUP



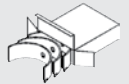



...Continued



<b>786</b>		 <b>70.00</b>	<b>Petrol</b>							
										
BE/PL	4	37.998/38.008	41.128/41.140	19.000	1.549	0.022/0.069	AL-LF	1015RA	<b>01-4116/4</b> STD 0.25 0.50	
MB/HL 3	2	48.000/48.100	63.800/64.000		2.325		AL-LF	04-4075	<b>H1067/5</b> STD 0.25 0.50	
MB/HL 1-5	5	43.990/44.000	47.705/47.718	19.000	1.841	0.023/0.081	AL-LF	1016RA		
MB/HL 1-5	9	43.990/44.000	47.705/47.718	19.000	1.848	0.020/0.057	AL-LF	4271RA	<b>H1091/5</b> STD	
MB/HL 3	1	43.990/44.000	47.705/47.718	23.910	1.848	0.020/0.057	AL-LF	4272RAH		
 EP280			 HR397				 NB815  NB814			
							23.00x35.00x7.00mm, FPM 70.00x88.00x8.00mm, FPM			









<b>787</b>		 <b>70.00</b>	<b>Petrol</b>						
<b>176 A6.000</b>	4 Cyl.	9.6:1	1108cc	<b>40kW (54)PS</b>			<b>TD1036</b>	<b>36</b>	
<b>176 B2.000</b>	4 Cyl.	9.6:1	1108cc	<b>40kW (54)PS</b>			<b>TD11847</b>	<b>39</b>	
<b>176 B2.000</b>	4 Cyl.	9.6:1	1108cc	<b>40kW (54)PS</b>			<b>TD4396</b>	<b>38</b>	

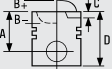
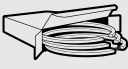



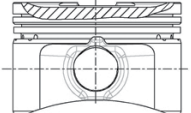
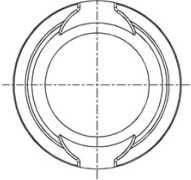

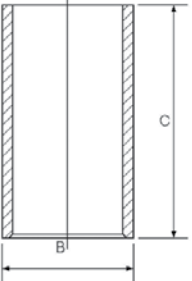

	STD		<b>08-142300-00</b>	STD	<b>14-010991-00 D</b>		
<b>87-142306-00</b>	0.40mm		<b>08-142306-00</b>	0.40mm	B 73.02 C 116.00		
<b>87-142308-00</b>	0.60mm		<b>08-142308-00</b>	0.60mm			
<b>A</b> 30.00			<b>1.20</b>		CR P		
<b>B-</b> 1.80			<b>1.20</b>		P		
<b>BØ</b> 60.00			<b>2.50</b>		P		
<b>D</b> 50.00							
 18x53							



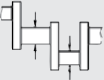
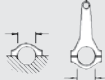



<b>787</b>		 <b>70.00</b>	<b>Petrol</b>							
										
BE/PL	4	37.998/38.008	41.128/41.140	19.000	1.549	0.022/0.069	AL-LF	1015RA	<b>01-4116/4</b> STD 0.25 0.50	
MB/HL 3	2	48.000/48.100	63.800/64.000		2.325		AL-LF	04-4075	<b>H1067/5</b> STD 0.25 0.50	
MB/HL 1-5	5	43.990/44.000	47.705/47.718	19.000	1.841	0.023/0.081	AL-LF	1016RA		
MB/HL 1-5	9	43.990/44.000	47.705/47.718	19.000	1.848	0.020/0.057	AL-LF	4271RA	<b>H1091/5</b> STD	
MB/HL 3	1	43.990/44.000	47.705/47.718	23.910	1.848	0.020/0.057	AL-LF	4272RAH		
 EP280			 HR397				 NB815  NB814			
							23.00x35.00x7.00mm, FPM 70.00x88.00x8.00mm, FPM →Eng.6315750 NA5061  NA5061 74.00x88.00x8.00mm, FPM Eng.6315750→			

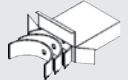

<b>788</b>	 <b>70.00</b>	<b>Petrol</b>				
<b>178 B9.033</b>	4 Cyl.	9.6:1	1108cc	<b>40kW (54)PS</b>	<b>TD26111</b>	<b>34</b>
			<b>NB815</b>  23.00x35.00x7.00mm, FPM			









<b>789</b>	 <b>70.00</b>	<b>Petrol</b>				
<b>187 A1.000</b>	4 Cyl.	9.6:1	1108cc	<b>40-42kW (54-57)PS</b>	<b>TD17847</b>	<b>40</b>

			
<b>87-142300-00</b> STD <b>87-142306-00</b> 0.40mm <b>87-142308-00</b> 0.60mm  <b>A</b> 30.00 <b>B-</b> 1.80 <b>BØ</b> 60.00 <b>D</b> 50.00  18x53	  	<b>08-142300-00</b> STD <b>08-142306-00</b> 0.40mm <b>08-142308-00</b> 0.60mm  1.20  CR P 1.20  P 2.50  P	<b>14-010991-00 D</b> <b>B 73.02 C 116.00</b>  

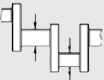
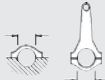
									
BE/PL	4	41.988/42.008	45.127/45.140	19.000	1.548	0.023/0.081	AL-LF	4275RA	<b>01-4154/4</b> STD 0.25 0.50
MB/HL 3	2	52.000/52.200	68.766/69.020		2.325		AL-LF	04-4076	<b>H1092/5</b> STD 0.25 0.50
MB/HL 1-5	10	47.980/48.000	51.705/51.718	19.000	1.848	0.020/0.067	AL-LF	4276RA	





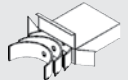







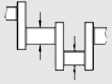

		
<b>EE5242</b>	<b>HR397</b>	<b>NB815</b>  23.00x35.00x7.00mm, FPM →Eng.2888158 <b>NA5061</b>  74.00x88.00x8.00mm, FPM <b>NA5057</b>  27.00x37.00x7.00mm, FPM Eng.2888158→

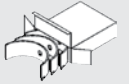

<b>790</b>	 <b>70.00</b>	<b>Petrol</b>				
<b>141 C2.000</b>	4 Cyl.		999cc	<b>31-33kW (42-45)PS</b>	<b>TD1070</b>	<b>41</b>
<b>156 A2.048</b>	4 Cyl.	9.2:1	999cc	<b>32kW (44)PS</b>	<b>TD1782</b>	<b>44</b>
<b>156 A2.048</b>	4 Cyl.	9.2:1	999cc	<b>32kW (44)PS</b>	<b>TD992</b>	<b>36</b>
<b>156 A2.146</b>	4 Cyl.	9.5:1	999cc	<b>33kW (45)PS</b>	<b>TD4594</b>	<b>44</b>
<b>156 A2.146</b>	4 Cyl.	9.5:1	999cc	<b>33kW (45)PS</b>	<b>TD993</b>	<b>44</b>
<b>156 A3.100</b>	4 Cyl.	9.5:1	999cc	<b>32-33kW (44-45)PS</b>	<b>TD4386</b>	<b>36</b>











									
BE/PL	4	37.998/38.008	41.128/41.140	19.000	1.549	0.022/0.069	AL-LF	1015RA	<b>01-4116/4</b> STD 0.25 0.50
MB/HL 3	2	48.000/48.100	63.800/64.000		2.325		AL-LF	04-4075	<b>H1067/5</b> STD 0.25 0.50
MB/HL 1-5	5	43.990/44.000	47.705/47.718	19.000	1.841	0.023/0.081	AL-LF	1016RA	

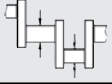





# FIAT GROUP



...Continued







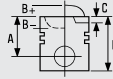

<b>790</b>		 <b>70.00</b>	<b>Petrol</b>							
										
MB/HL 1-5	9	43.990/44.000	47.705/47.718	19.000	1.848	0.020/0.057	AL-LF	4271RA	<b>H1091/5</b> STD	
MB/HL 3	1	43.990/44.000	47.705/47.718	23.910	1.848	0.020/0.057	AL-LF	4272RAH		
										
EP280		HR397			<b>NB815</b>  23.00x35.00x7.00mm, FPM <b>NB814</b>  70.00x88.00x8.00mm, FPM					

<b>791</b>		 <b>70.00</b>	<b>Petrol</b>							
<b>146 B4.000</b>	4 Cyl.	9.8:1	999cc	<b>31-35kW (42-48)PS</b>				<b>TD18820</b>	<b>42</b>	
<b>156 A2.256</b>	4 Cyl.	9.5:1	999cc	<b>33kW (45)PS</b>				<b>TD4595</b>		



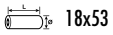
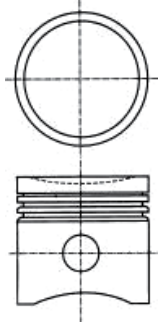



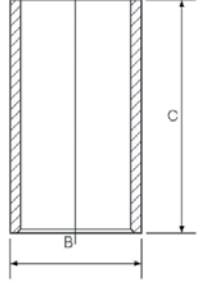

									
BE/PL	4	37.998/38.008	41.128/41.140	19.000	1.549	0.022/0.069	AL-LF	1015RA	<b>01-4116/4</b> STD 0.25 0.50
MB/HL 3	2	48.000/48.100	63.800/64.000		2.325		AL-LF	04-4075	<b>H1067/5</b> STD 0.25 0.50
MB/HL 1-5	5	43.990/44.000	47.705/47.718	19.000	1.841	0.023/0.081	AL-LF	1016RA	
MB/HL 1-5	9	43.990/44.000	47.705/47.718	19.000	1.848	0.020/0.057	AL-LF	4271RA	<b>H1091/5</b> STD
MB/HL 3	1	43.990/44.000	47.705/47.718	23.910	1.848	0.020/0.057	AL-LF	4272RAH	



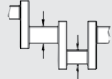
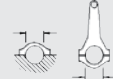

<b>792</b>		 <b>70.00</b>	<b>Petrol</b>							
<b>146 E1.011</b>	4 Cyl.	11.65:1	999cc	<b>47-56kW (64-76)PS</b>				<b>TD25023</b>	<b>34</b>	
										
					<b>NA5057</b>  27.00x37.00x7.00mm, FPM					



<b>793</b>	 <b>70.00</b>	<b>Petrol</b>				
<b>156 A2.000</b>	4 Cyl.	9.5:1	999cc	<b>31-37kW (42-50)PS</b>	<b>TD16230</b>	<b>43</b>
<b>156 A2.000</b>	4 Cyl.	9.5:1	999cc	<b>33-37kW (45-50)PS</b>	<b>TD4592</b>	<b>35</b>
<b>156 A2.100</b>	4 Cyl.	9:1	999cc	<b>32-33kW (44-45)PS</b>	<b>TD4387</b>	<b>36</b>
<b>156 A3.000</b>	4 Cyl.	9.8:1	999cc	<b>37kW (50)PS</b>	<b>TD16209</b>	<b>37</b>



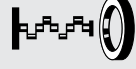



			
<b>87-154200-00</b> STD <b>87-154206-00</b> 0.40mm <b>87-154208-00</b> 0.60mm  <b>A</b> 33.90 <b>B-</b> 0.50 <b>D</b> 57.40  18x53		<b>08-154200-00</b> STD <b>08-154206-00</b> 0.40mm <b>08-154208-00</b> 0.60mm  1.50  CR P 1.50  P 3.00  CR [15]	<b>14-010991-00 D</b> <b>B 73.02 C 116.00</b>  

[15] Steel                      [15] Acier                      [15] Acciaio                      [15] Acero

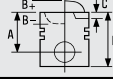
									
BE/PL	4	37.998/38.008	41.128/41.140	19.000	1.549	0.022/0.069	AL-LF	1015RA	<b>01-4116/4</b> STD 0.25 0.50
MB/HL 3	2	48.000/48.100	63.800/64.000		2.325		AL-LF	04-4075	<b>H1067/5</b> STD 0.25 0.50
MB/HL 1-5	5	43.990/44.000	47.705/47.718	19.000	1.841	0.023/0.081	AL-LF	1016RA	
MB/HL 1-5	9	43.990/44.000	47.705/47.718	19.000	1.848	0.020/0.057	AL-LF	4271RA	<b>H1091/5</b> STD
MB/HL 3	1	43.990/44.000	47.705/47.718	23.910	1.848	0.020/0.057	AL-LF	4272RAH	

		
<b>EP280</b>	<b>HR397</b>	<b>NB815</b>  23.00x35.00x7.00mm, FPM <b>NB814</b>  70.00x88.00x8.00mm, FPM



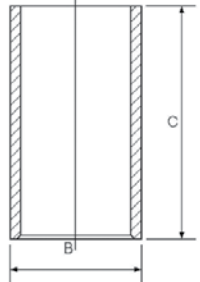







<b>794</b>	 <b>70.00</b>	<b>Petrol</b>			
<b>156 A2.0157</b>	4 Cyl.	9:1	999cc	<b>33kW (45)PS</b>	<b>TD22227</b>
<b>156 A2.050</b>	4 Cyl.	9:1	999cc	<b>33kW (45)PS</b>	<b>TD22228</b>

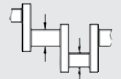

			
	<b>08-154200-00</b> STD <b>08-154206-00</b> 0.40mm <b>08-154208-00</b> 0.60mm  1.50  CR P 1.50  P 3.00  CR [15]	<b>14-010991-00 D</b> <b>B 73.02 C 116.00</b>  	







[15] Steel                      [15] Acier                      [15] Acciaio                      [15] Acero

# FIAT GROUP

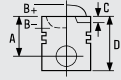
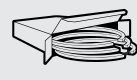





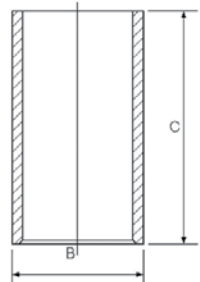



...Continued

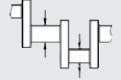



794		 70.00	Petrol						
									
BE/PL	4	37.998/38.008	41.128/41.140	19.000	1.549	0.022/0.069	AL-LF	1015RA	<b>01-4116/4</b> STD 0.25 0.50
MB/HL 3	2	48.000/48.100	63.800/64.000		2.325		AL-LF	04-4075	<b>H1067/5</b> STD 0.25 0.50
MB/HL 1-5	5	43.990/44.000	47.705/47.718	19.000	1.841	0.023/0.081	AL-LF	1016RA	
MB/HL 1-5	9	43.990/44.000	47.705/47.718	19.000	1.848	0.020/0.057	AL-LF	4271RA	<b>H1091/5</b> STD
MB/HL 3	1	43.990/44.000	47.705/47.718	23.910	1.848	0.020/0.057	AL-LF	4272RAH	



795		 70.00	Petrol							
156 A2.100	4 Cyl.	9:1	999cc	32kW (44)PS			TD4593		35	





			
	<b>08-154200-00</b> STD <b>08-154206-00</b> 0.40mm <b>08-154208-00</b> 0.60mm  1.50  CR P 1.50  P 3.00  CR [15]	<b>14-010991-00 D</b> <b>B 73.02 C 116.00</b>  	



[15] Steel      [15] Acier      [15] Acciaio      [15] Acero







									
BE/PL	4	37.998/38.008	41.128/41.140	19.000	1.549	0.022/0.069	AL-LF	1015RA	<b>01-4116/4</b> STD 0.25 0.50
MB/HL 3	2	48.000/48.100	63.800/64.000		2.325		AL-LF	04-4075	<b>H1067/5</b> STD 0.25 0.50
MB/HL 1-5	5	43.990/44.000	47.705/47.718	19.000	1.841	0.023/0.081	AL-LF	1016RA	
MB/HL 1-5	9	43.990/44.000	47.705/47.718	19.000	1.848	0.020/0.057	AL-LF	4271RA	<b>H1091/5</b> STD
MB/HL 3	1	43.990/44.000	47.705/47.718	23.910	1.848	0.020/0.057	AL-LF	4272RAH	



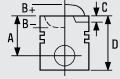
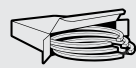



		
EP280	HR397	<b>NB815</b>  23.00x35.00x7.00mm, FPM <b>NB814</b>  70.00x88.00x8.00mm, FPM



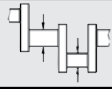
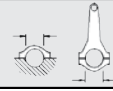

796		 70.00	Petrol							
310 A1.011	4 Cyl.	12.15:1	999cc	54-63kW (73-86)PS			TD24640			

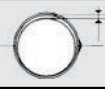

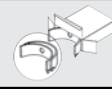
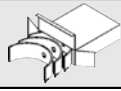
		
		<b>NA5057</b>  27.00x37.00x7.00mm, FPM <b>NA5061</b>  74.00x88.00x8.00mm, FPM









<b>797</b>	 <b>70.80</b>	<b>Petrol</b>				
<b>169 A4.000</b>	4 Cyl.	11.1:1	1242cc	<b>49-51kW (67-69)PS</b>	<b>TD25192</b>	<b>46</b>
<b>169 A4.000</b>	4 Cyl.	11.1:1	1242cc	<b>51kW (69)PS</b>	<b>TD20928</b>	<b>45</b>
<b>199 A4.000 Euro 4 (D4)</b>	4 Cyl.	11:1	1242cc	<b>48-51kW (65-69)PS</b>	<b>TD20242</b>	<b>62</b>

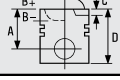
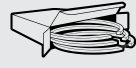



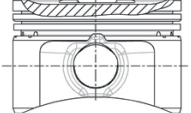
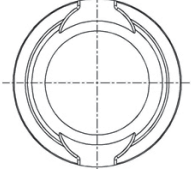



			
	<b>08-138400-00</b> STD <b>08-138406-00</b> 0.40mm <b>08-138408-00</b> 0.60mm  1.19  NT P 1.20  P 2.50  P		



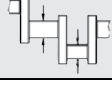
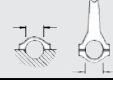

									
BE/PL	4	41.988/42.008	45.127/45.140	19.000	1.548	0.023/0.081	AL-LF	4275RA	<b>01-4154/4</b> STD 0.25 0.50
MB/HL 3	2	52.000/52.200	68.766/69.020		2.325		AL-LF	04-4076	<b>H1092/5</b> STD 0.25 0.50
MB/HL 1-5	10	47.980/48.000	51.705/51.718	19.000	1.848	0.020/0.067	AL-LF	4276RA	

		
<b>EE5180</b>	<b>HR397</b>	<b>NA5057</b>  27.00x37.00x7.00mm, FPM <b>NA5061</b>  74.00x88.00x8.00mm, FPM

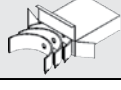
<b>798</b>	 <b>70.80</b>	<b>Petrol</b>				
<b>176 A7.000</b>	4 Cyl.	9.6:1	1242cc	<b>43-44kW (58-60)PS</b>	<b>TD1037</b>	<b>47</b>
<b>840 A3.000</b>	4 Cyl.	9.8:1	1242cc	<b>44kW (60)PS</b>	<b>TD1839</b>	<b>64</b>

			
<b>87-138400-10</b> STD <b>87-138406-10</b> 0.40mm <b>87-138408-10</b> 0.60mm  A 28.00 B- 2.50 D 47.50  18x53	  	<b>08-138400-00</b> STD <b>08-138406-00</b> 0.40mm <b>08-138408-00</b> 0.60mm  1.19  NT P 1.20  P 2.50  P	

									
BE/PL	4	41.988/42.008	45.127/45.140	19.000	1.548	0.023/0.081	AL-LF	4275RA	<b>01-4154/4</b> STD 0.25 0.50
MB/HL 3	2	52.000/52.200	68.766/69.020		2.325		AL-LF	04-4076	<b>H1092/5</b> STD 0.25 0.50
MB/HL 1-5	10	47.980/48.000	51.705/51.718	19.000	1.848	0.020/0.067	AL-LF	4276RA	

		
<b>EE5242</b>	<b>HR397</b>	<b>NB815</b>  23.00x35.00x7.00mm, FPM <b>NA5061</b>  74.00x88.00x8.00mm, FPM

# FIAT GROUP

<b>799</b>	<b>70.80</b>	<b>Petrol</b>				
<b>176 A8.000</b>	4 Cyl.	9.8:1	1242cc	<b>54kW (73)PS</b>	<b>TD1038</b>	<b>48</b>
<b>176 B4.000</b>	4 Cyl.	9.8:1	1242cc	<b>44kW (60)PS</b>	<b>TD1076</b>	<b>50</b>

<b>87-138400-40</b> <b>87-138406-40</b> STD 0.40mm  <b>A</b> 28.00 <b>B-</b> 1.80 <b>C</b> 1.10 <b>D</b> 48.00 18x53	<b>08-138400-00</b> STD <b>08-138406-00</b> 0.40mm <b>08-138408-00</b> 0.60mm  1.19  NT P 1.20  P 2.50  P		

BE/PL	4	41.988/42.008	45.127/45.140	19.000	1.548	0.023/0.081	AL-LF	4275RA	<b>01-4154/4</b> STD 0.25 0.50
MB/HL 3	2	52.000/52.200	68.766/69.020		2.325		AL-LF	04-4076	<b>H1092/5</b> STD 0.25 0.50
MB/HL 1-5	10	47.980/48.000	51.705/51.718	19.000	1.848	0.020/0.067	AL-LF	4276RA	

<b>EV670</b>	<b>HR397</b>	<b>NB815</b> 23.00x35.00x7.00mm, FPM <b>NA5061</b> 74.00x88.00x8.00mm, FPM



<b>800</b>	<b>70.80</b>	<b>Petrol</b>				
<b>176 B1.000</b>	4 Cyl.	10.2:1	1242cc	<b>44kW (60)PS</b>	<b>TD1032</b>	<b>49</b>







	<b>08-138400-00</b> STD <b>08-138406-00</b> 0.40mm <b>08-138408-00</b> 0.60mm  1.19  NT P 1.20  P 2.50  P		



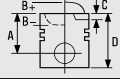
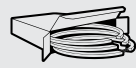

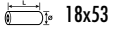
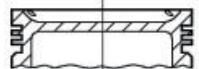
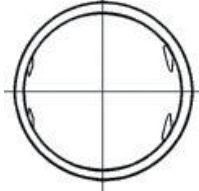



BE/PL	4	41.988/42.008	45.127/45.140	19.000	1.548	0.023/0.081	AL-LF	4275RA	<b>01-4154/4</b> STD 0.25 0.50
MB/HL 3	2	52.000/52.200	68.766/69.020		2.325		AL-LF	04-4076	<b>H1092/5</b> STD 0.25 0.50
MB/HL 1-5	10	47.980/48.000	51.705/51.718	19.000	1.848	0.020/0.067	AL-LF	4276RA	



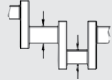
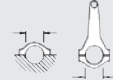

<b>EV670</b>	<b>HR397</b>	<b>NB815</b> 23.00x35.00x7.00mm, FPM <b>NA5061</b> 74.00x88.00x8.00mm, FPM







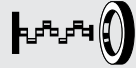



**801**  **70.80** **Petrol**   
**176 B9.000** 4 Cyl. 10.2:1 1242cc **63kW (86)PS** **TD9727** **52**



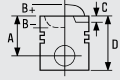
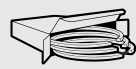

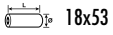
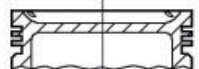
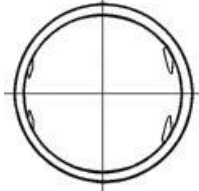



			
<b>87-138400-00</b> <b>87-138406-00</b> STD 0.40mm  <b>A</b> 28.05 <b>B-</b> 5.70 <b>C</b> 1.50 <b>D</b> 48.00  18x53	  	<b>08-138400-00</b> STD <b>08-138406-00</b> 0.40mm <b>08-138408-00</b> 0.60mm  1.19  NT P 1.20  P 2.50  P	



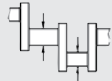
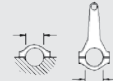

									
BE/PL	4	41.988/42.008	45.127/45.140	19.000	1.548	0.023/0.081	AL-LF	4275RA	<b>01-4154/4</b> STD 0.25 0.50
MB/HL 3	2	52.000/52.200	68.766/69.020		2.325		AL-LF	04-4076	<b>H1092/5</b> STD 0.25 0.50
MB/HL 1-5	10	47.980/48.000	51.705/51.718	19.000	1.848	0.020/0.067	AL-LF	4276RA	

		
<b>EE5180</b> →06/99	<b>HR397</b>	<b>NA5057</b>  27.00x37.00x7.00mm, FPM <b>NA5061</b>  74.00x88.00x8.00mm, FPM

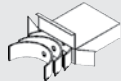
**802**  **70.80** **Petrol**   
**176 B9.000** 4 Cyl. 10.2:1 1242cc **63kW (86)PS** **TD11849** **51**

			
<b>87-138400-00</b> <b>87-138406-00</b> STD 0.40mm  <b>A</b> 28.05 <b>B-</b> 5.70 <b>C</b> 1.50 <b>D</b> 48.00  18x53	  	<b>08-138400-00</b> STD <b>08-138406-00</b> 0.40mm <b>08-138408-00</b> 0.60mm  1.19  NT P 1.20  P 2.50  P	

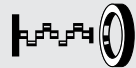
									
BE/PL	4	41.988/42.008	45.127/45.140	19.000	1.548	0.023/0.081	AL-LF	4275RA	<b>01-4154/4</b> STD 0.25 0.50
MB/HL 3	2	52.000/52.200	68.766/69.020		2.325		AL-LF	04-4076	<b>H1092/5</b> STD 0.25 0.50
MB/HL 1-5	10	47.980/48.000	51.705/51.718	19.000	1.848	0.020/0.067	AL-LF	4276RA	

		
<b>EE5242</b>	<b>HR397</b>	<b>NA5057</b>  27.00x37.00x7.00mm, FPM <b>NA5061</b>  74.00x88.00x8.00mm, FPM

# FIAT GROUP

<b>803</b>	<b>70.80</b>	<b>Petrol</b>	
<b>178 B5.000</b>	4 Cyl.	9.8:1	1242cc
			<b>50-55kW (68-75)PS</b>
			<b>TD10188 53</b>

<b>87-138400-40</b> <b>87-138406-40</b>  STD 0.40mm  A 28.00 B- 1.80 C 1.10 D 48.00 	<b>08-138400-00</b> <b>08-138406-00</b> <b>08-138408-00</b>  STD 0.40mm 0.60mm  1.19  NT P 1.20  P 2.50  P		



BE/PL	4	41.988/42.008	45.127/45.140	19.000	1.548	0.023/0.081	AL-LF	4275RA	<b>01-4154/4</b> STD 0.25 0.50
MB/HL 3	2	52.000/52.200	68.766/69.020		2.325		AL-LF	04-4076	<b>H1092/5</b> STD 0.25 0.50
MB/HL 1-5	10	47.980/48.000	51.705/51.718	19.000	1.848	0.020/0.067	AL-LF	4276RA	







<b>EE5242</b> →Eng.2935743 <b>EE5180</b> Eng.2935744 →	<b>HR397</b>	<b>NB815</b> 23.00x35.00x7.00mm, FPM →Eng.2935743 <b>NA5061</b> 74.00x88.00x8.00mm, FPM <b>NA5057</b> 27.00x37.00x7.00mm, FPM Eng.2935744 →



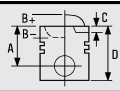
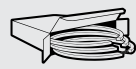

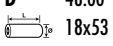
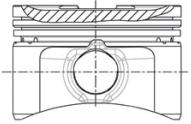
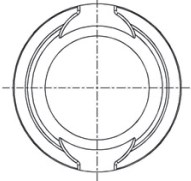



<b>804</b>	<b>70.80</b>	<b>Petrol</b>	
<b>178 B7.045</b>	4 Cyl.	1242cc	<b>44-60kW (60-82)PS</b>
			<b>TD18895 54</b>
<b>178 C4.066</b>	4 Cyl.	1242cc	<b>44-46kW (60-63)PS</b>
			<b>TD20237 55</b>



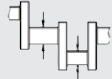
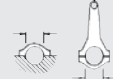

BE/PL	4	41.988/42.008	45.127/45.140	19.000	1.548	0.023/0.081	AL-LF	4275RA	<b>01-4154/4</b> STD 0.25 0.50
MB/HL 3	2	52.000/52.200	68.766/69.020		2.325		AL-LF	04-4076	<b>H1092/5</b> STD 0.25 0.50
MB/HL 1-5	10	47.980/48.000	51.705/51.718	19.000	1.848	0.020/0.067	AL-LF	4276RA	

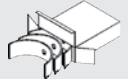

<b>EE5242</b> →Eng.2935743 <b>EE5180</b> Eng.2935744 →	<b>HR397</b>	<b>NB815</b> 23.00x35.00x7.00mm, FPM →Eng.2935743 <b>NA5061</b> 74.00x88.00x8.00mm, FPM <b>NA5057</b> 27.00x37.00x7.00mm, FPM Eng.2935744 →







<b>805</b>	 <b>70.80</b>	<b>Petrol</b>				
<b>178 E2.000</b>	4 Cyl.	9.8:1	1242cc	<b>50-54kW (68-73)PS</b>	<b>TD16737</b>	<b>56</b>
<b>223 A5.000</b>	4 Cyl.	9.8:1	1242cc	<b>48kW (65)PS</b>	<b>TD15828</b>	<b>63</b>



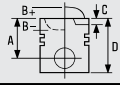
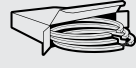

			
<b>87-138400-40</b> <b>87-138406-40</b>  <b>A</b> 28.00 <b>B-</b> 1.80 <b>C</b> 1.10 <b>D</b> 48.00  18x53	<b>STD</b> 0.40mm    	<b>08-138400-00</b> STD <b>08-138406-00</b> 0.40mm <b>08-138408-00</b> 0.60mm  1.19  NT P 1.20  P 2.50  P	

									
BE/PL	4	41.988/42.008	45.127/45.140	19.000	1.548	0.023/0.081	AL-LF	4275RA	<b>01-4154/4</b> STD 0.25 0.50
MB/HL 3	2	52.000/52.200	68.766/69.020		2.325		AL-LF	04-4076	<b>H1092/5</b> STD 0.25 0.50
MB/HL 1-5	10	47.980/48.000	51.705/51.718	19.000	1.848	0.020/0.067	AL-LF	4276RA	

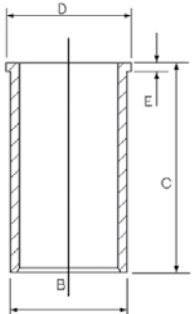
		
<b>EE5242</b>	<b>HR397</b>	<b>NA815</b>  23.00x35.00x7.00mm, FPM <b>NA5061</b>  74.00x88.00x8.00mm, FPM

<b>806</b>	 <b>70.80</b>	<b>Petrol</b>			
<b>178 E8.011</b>	4 Cyl.	9.8:1	1242cc	<b>48-49kW (65-67)PS</b>	<b>TD25005</b>
<b>178 E9.011</b>	4 Cyl.	11:1	1242cc	<b>50-52kW (68-71)PS</b>	<b>TD24630</b>

			
	<b>08-138400-00</b> STD <b>08-138406-00</b> 0.40mm <b>08-138408-00</b> 0.60mm  1.19  NT P 1.20  P 2.50  P	<b>14-021080-00 D</b> <b>B</b> 73.80 <b>C</b> 128.00 <b>D</b> 75.00 <b>E</b> 5.00  	

		
		<b>NA5057</b>  27.00x37.00x7.00mm, FPM

# FIAT GROUP

<b>807</b>	<b>70.80</b>	<b>Petrol</b>	
182 B2.000	4 Cyl.	1242cc	60-64kW (82-87)PS
			TD11807 <b>57</b>

<b>87-138400-00</b> <b>87-138406-00</b> STD 0.40mm  <b>A</b> 28.05 <b>B-</b> 5.70 <b>C</b> 1.50 <b>D</b> 48.00 18x53	   1.19  NT P 1.20  P 2.50  P	<b>08-138400-00</b> STD <b>08-138406-00</b> 0.40mm <b>08-138408-00</b> 0.60mm	

BE/PL 4	MB/HL 3 2	MB/HL 1-5 10	41.988/42.008	45.127/45.140	19.000	1.548	0.023/0.081	AL-LF	4275RA	<b>01-4154/4</b> STD 0.25 0.50
			52.000/52.200	68.766/69.020		2.325		AL-LF	04-4076	<b>H1092/5</b> STD 0.25 0.50
			47.980/48.000	51.705/51.718	19.000	1.848	0.020/0.067	AL-LF	4276RA	







EE5180	HR397	NA5057  27.00x37.00x7.00mm, FPM	NA5061  74.00x88.00x8.00mm, FPM



<b>808</b>	<b>70.80</b>	<b>Petrol</b>	
188 A4.000	4 Cyl.	10.6:1	1242cc
			44kW (60)PS
			TD15501 <b>59</b>







<b>87-138400-40</b> <b>87-138406-40</b> STD 0.40mm  <b>A</b> 28.00 <b>B-</b> 1.80 <b>C</b> 1.10 <b>D</b> 48.00 18x53	   1.19  NT P 1.20  P 2.50  P	<b>14-021080-00 D</b> <b>B</b> 73.80 <b>C</b> 128.00 <b>D</b> 75.00 <b>E</b> 5.00 	



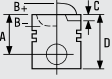
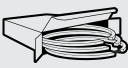





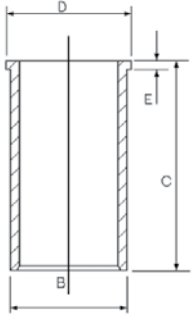

BE/PL 4	MB/HL 3 2	MB/HL 1-5 10	41.988/42.008	45.127/45.140	19.000	1.548	0.023/0.081	AL-LF	4275RA	<b>01-4154/4</b> STD 0.25 0.50
			52.000/52.200	68.766/69.020		2.325		AL-LF	04-4076	<b>H1092/5</b> STD 0.25 0.50
			47.980/48.000	51.705/51.718	19.000	1.848	0.020/0.067	AL-LF	4276RA	

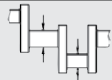



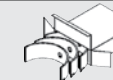

...Continued

<b>808</b>	 <b>70.80</b>	<b>Petrol</b>
		
<b>EE5242</b>	<b>HR397</b>	<b>NB815</b>  23.00x35.00x7.00mm, FPM →Eng.2939661 <b>NA5061</b>  74.00x88.00x8.00mm, FPM <b>NA5057</b>  27.00x37.00x7.00mm, FPM Eng.2939662→

<b>809</b>	 <b>70.80</b>	<b>Petrol</b>				
<b>188 A4.000</b>	4 Cyl.	9.5:1	1242cc	44kW (60)PS	<b>TD12790</b>	<b>58</b>

			
<b>87-138400-40</b> STD <b>87-138406-40</b> 0.40mm  <b>A</b> 28.00 <b>B-</b> 1.80 <b>C</b> 1.10 <b>D</b> 48.00  18x53	<b>08-138400-00</b> STD <b>08-138406-00</b> 0.40mm <b>08-138408-00</b> 0.60mm  <b>1.19</b>  NT P <b>1.20</b>  P <b>2.50</b>  P	<b>14-021080-00 D</b> <b>B</b> 73.80 <b>C</b> 128.00 <b>D</b> 75.00 <b>E</b> 5.00  	

										
BE/PL	4	41.988/42.008	45.127/45.140	19.000	1.548	0.023/0.081	AL-LF	4275RA	01-4154/4 STD 0.25 0.50	H1092/5 STD 0.25 0.50
MB/HL 3	2	52.000/52.200	68.766/69.020	19.000	1.848	0.020/0.067	AL-LF	04-4076	4276RA	
MB/HL 1-5	10	47.980/48.000	51.705/51.718	19.000	1.848	0.020/0.067	AL-LF	4276RA		

		
<b>EE5242</b> →Eng.2939661 <b>EV670</b> Eng.2939662→	<b>HR397</b>	<b>NA5057</b>  27.00x37.00x7.00mm, FPM →Eng.2939661 <b>NB815</b>  23.00x35.00x7.00mm, FPM →Eng.2939600 <b>NA5061</b>  74.00x88.00x8.00mm, FPM

<b>810</b>	<b>70.80</b>	<b>Petrol</b>	
<b>188 A5.000</b>	4 Cyl.	1242cc	<b>57-59kW (78-80)PS</b>
			<b>TD12791 60</b>

 <b>87-138400-30</b> <b>87-138406-30</b> STD 0.40mm  A 28.00 B- 5.10 D 48.00  18x49	 <b>08-138400-00</b> STD <b>08-138406-00</b> 0.40mm <b>08-138408-00</b> 0.60mm  1.19  NT P 1.20  P 2.50  P	 <b>14-021080-00 D</b> B 73.80 C 128.00 D 75.00 E 5.00 	
---	---	--	--

BE/PL	4	41.988/42.008	45.127/45.140	19.000	1.548	0.023/0.081	AL-LF	4275RA	<b>01-4154/4</b> STD 0.25 0.50	
MB/HL 3	2	52.000/52.200	68.766/69.020		2.325		AL-LF	04-4076	<b>H1092/5</b> STD 0.25 0.50	
MB/HL 1-5	10	47.980/48.000	51.705/51.718	19.000	1.848	0.020/0.067	AL-LF	4276RA		

<b>EE5180</b>			<b>HR397</b>					<b>NA5057</b> 27.00x37.00x7.00mm, FPM	
								<b>LK5001</b> [19] 74.00x187.50x17.000mm, FPM	







[19] Specification: Oil Seal in housing      [19] Caractéristiques: Bague d'étanchéité dans son logement      [19] Specifiche: Paraolio in sede      [19] Especificaciones: Retén de aceite de la carcasa











<b>811</b>	<b>70.80</b>	<b>Petrol</b>	
<b>188 A5.000 Euro 3 (D3)</b>	4 Cyl.	10.6:1	<b>59kW (80)PS</b>
			<b>TD15500 61</b>

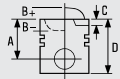
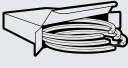







 <b>87-138400-30</b> <b>87-138406-30</b> STD 0.40mm  A 28.00 B- 5.10 D 48.00  18x49	 <b>08-138400-00</b> STD <b>08-138406-00</b> 0.40mm <b>08-138408-00</b> 0.60mm  1.19  NT P 1.20  P 2.50  P	 <b>14-021080-00 D</b> B 73.80 C 128.00 D 75.00 E 5.00 	
---	---	--	--



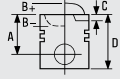





BE/PL	4	41.988/42.008	45.127/45.140	19.000	1.548	0.023/0.081	AL-LF	4275RA	<b>01-4154/4</b> STD 0.25 0.50
MB/HL 3	2	52.000/52.200	68.766/69.020		2.325		AL-LF	04-4076	<b>H1092/5</b> STD 0.25 0.50
MB/HL 1-5	10	47.980/48.000	51.705/51.718	19.000	1.848	0.020/0.067	AL-LF	4276RA	

...Continued

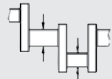
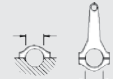
<b>811</b>	 <b>70.80</b>	<b>Petrol</b>
		
<b>EE5242</b>	<b>HR397</b>	<b>NA5057</b>  27.00x37.00x7.00mm, FPM <b>LK5001</b>  [19] 74.00x187.50x17.000mm, FPM
[19] Specification: Oil Seal in housing	[19] Caractéristiques: Bague d'étanchéité dans son logement	[19] Specifiche: Paraolio in sede [19] Especificaciones: Retén de aceite de la carcasa



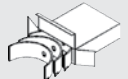

<b>812</b>	 <b>70.80</b>	<b>Petrol</b>			
<b>223 A3.011</b>	4 Cyl.	10.2:1	1242cc	<b>59kW (80)PS</b>	<b>TD24997</b>
					
	<b>08-138400-00</b> STD <b>08-138406-00</b> 0.40mm <b>08-138408-00</b> 0.60mm  1.19  NT P 1.20  P 2.50  P				
					
[19] Specification: Oil Seal in housing	[19] Caractéristiques: Bague d'étanchéité dans son logement	[19] Specifiche: Paraolio in sede	[19] Especificaciones: Retén de aceite de la carcasa		







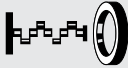

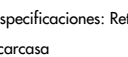

<b>813</b>	 <b>72.00</b>	<b>Petrol</b>				
<b>169 A3.000</b>	4 Cyl.		1368cc	<b>74kW (100)PS</b>	<b>TD20277</b>	<b>65</b>
<b>192 B2.000</b>	4 Cyl.	11:1	1368cc	<b>66kW (90)PS</b>	<b>TD18571</b>	<b>66</b>
<b>192 B2.000</b>	4 Cyl.	11:1	1368cc	<b>66kW (90)PS</b>	<b>TD20952</b>	<b>67</b>
<b>843 A 1.000</b>	4 Cyl.	10.8:1	1368cc	<b>70kW (95)PS</b>	<b>TD17979</b>	<b>77</b>
<b>955 A1.000</b>	4 Cyl.		1368cc	<b>57-58kW (78-79)PS</b>	<b>TD23448</b>	<b>79</b>
						
	<b>08-433200-00</b> STD <b>08-433206-00</b> 0.40mm  1.00  NT [15] 1.20  P 2.00  P					
[15] Steel	[15] Acier	[15] Acciaio	[15] Acero			

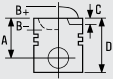

									
BE/PL	4	41.988/42.008	45.127/45.140	19.000	1.548	0.023/0.081	AL-LF	4275RA	<b>01-4154/4</b> STD 0.25 0.50
MB/HL 3	2	52.000/52.200	68.766/69.020		2.325		AL-LF	04-4076	<b>H1092/5</b> STD 0.25 0.50
MB/HL 1-5	10	47.980/48.000	51.705/51.718	19.000	1.848	0.020/0.067	AL-LF	4276RA	



# FIAT GROUP



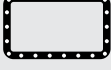
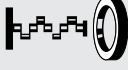

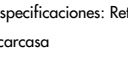



...Continued



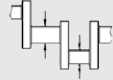

<b>813</b>	 <b>72.00</b>	<b>Petrol</b>
		
<b>EE5242</b>	<b>HR397</b>	<b>NA5057</b>  27.00x37.00x7.00mm, FPM <b>LK5001</b>  [19] 74.00x187.50x17.000mm, FPM
[19] Specification: Oil Seal in housing	[19] Caractéristiques: Bague d'étanchéité dans son logement	[19] Specifiche: Paraolio in sede [19] Especificaciones: Retén de aceite de la carcasa

<b>814</b>	 <b>72.00</b>	<b>Petrol</b>			
<b>178 F3.011</b>	4 Cyl.	10.4:1	1368cc	<b>59-60kW (80-82)PS</b>	<b>TD24633</b>
					
	<b>08-436800-00</b> STD <b>08-436806-00</b> 0.40mm				
	1.00  NT [15] 1.20  P 2.00  CR P				
					
[15] Steel	[15] Acier	[15] Acciaio	[15] Acero		

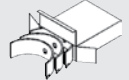

		
<b>NA5057</b>  27.00x37.00x7.00mm, FPM <b>LK5001</b>  [19] 74.00x187.50x17.000mm, FPM		
[19] Specification: Oil Seal in housing	[19] Caractéristiques: Bague d'étanchéité dans son logement	[19] Specifiche: Paraolio in sede [19] Especificaciones: Retén de aceite de la carcasa

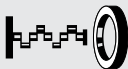

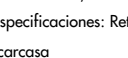





<b>815</b>	 <b>72.00</b>	<b>Petrol</b>					
<b>198 A1.000</b>	4 Cyl.	1368cc	<b>110kW (150)PS</b>	<b>Turbocharged</b>	<b>TD23452</b>	<b>68</b>	
<b>198 A1.000</b>	4 Cyl.	9.6:1	1368cc	<b>110-112kW (150-152)PS</b>	<b>Turbocharged</b>	<b>TD21045</b>	<b>69</b>
<b>198 A4.000</b>	4 Cyl.	9.6:1	1368cc	<b>88kW (120)PS</b>	<b>Turbocharged</b>	<b>TD21046</b>	<b>69</b>
<b>198 A4.000</b>	4 Cyl.	9.8:1	1368cc	<b>88kW (120)PS</b>	<b>Turbo Intercooled</b>	<b>TD23921</b>	<b>68</b>
<b>198 A7.000</b>	4 Cyl.	9.8:1	1368cc	<b>103kW (140)PS</b>	<b>Turbocharged</b>	<b>TD24595</b>	<b>68</b>
<b>199 A8.000</b>	4 Cyl.	1368cc		<b>114kW (155)PS</b>	<b>Turbocharged</b>	<b>TD21700</b>	<b>70</b>
<b>199 A8.000</b>	4 Cyl.	9.8:1	1368cc	<b>114-132kW (155-180)PS</b>	<b>Turbocharged</b>	<b>TD24567</b>	<b>68</b>



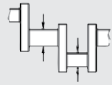
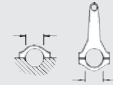

									
BE/PL	4	41.990/42.008	45.128/45.138	19.000	1.548	0.024/0.068	AL-LF	01-4079	<b>01-4079/4</b> STD
MB/HL 3	2	52.000/52.200	68.766/69.020		2.325		AL-LF	04-4076	<b>H1092/5</b> STD 0.25 0.50
MB/HL 1-5	10	47.980/48.000	51.705/51.718	19.000	1.848	0.020/0.067	AL-LF	4276RA	
SE/PB	1	17.970/17.974	20.775/20.800	22.000			BS-LF	55-4078	<b>55-4078</b> SEMI

		
<b>EE5180</b>	<b>HR397</b>	<b>NA5057</b>  27.00x37.00x7.00mm, FPM <b>LK5001</b>  [19] 74.00x187.50x17.000mm, FPM
[19] Specification: Oil Seal in housing	[19] Caractéristiques: Bague d'étanchéité dans son logement	[19] Specifiche: Paraolio in sede [19] Especificaciones: Retén de aceite de la carcasa

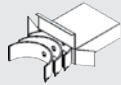









<b>816</b>	 <b>72.00</b>	<b>Petrol</b>					
<b>198 A1.000</b>	4 Cyl.	9.6:1	1368cc	<b>110kW (150)PS</b>	<b>Turbocharged</b>	<b>TD21041</b>	<b>68</b>
<b>198 A4.000</b>	4 Cyl.	9.6:1	1368cc	<b>88kW (120)PS</b>	<b>Turbocharged</b>	<b>TD21040</b>	<b>70</b>
<b>198 A7.000</b>	4 Cyl.	9.8:1	1368cc	<b>103kW (140)PS</b>	<b>Turbo Intercooled</b>	<b>TD24646</b>	<b>68</b>
<b>198 A7.000</b>	4 Cyl.	9.8:1	1368cc	<b>103kW (140)PS</b>	<b>Turbo Intercooled</b>	<b>TD24650</b>	<b>68</b>

										
BE/PL	4	41.990/42.008	45.128/45.138	19.000	1.548	0.024/0.068	AL-LF	01-4079	<b>01-4079/4</b> STD	
MB/HL 3	2	52.000/52.200	68.766/69.020		2.325		AL-LF	04-4076	<b>H1092/5</b> STD 0.25 0.50	
MB/HL 1-5	10	47.980/48.000	51.705/51.718	19.000	1.848	0.020/0.067	AL-LF	4276RA		
SE/PB	1	17.970/17.974	20.775/20.800	22.000			BS-LF	55-4078	<b>55-4078</b> SEMI	

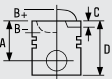
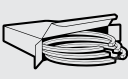







		
<b>EE5242</b>	<b>HR397</b>	<b>NA5057</b>  27.00x37.00x7.00mm, FPM <b>LK5001</b>  [19] 74.00x187.50x17.000mm, FPM



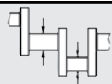
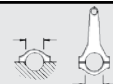

[19] Specification: Oil Seal in housing      [19] Caractéristiques: Bague d'étanchéité dans son logement      [19] Specifiche: Paraolio in sede      [19] Especificaciones: Retén de aceite de la carcasa

<b>817</b>	 <b>72.00</b>	<b>Petrol</b>			
<b>199 A1.000</b>	4 Cyl.		1368cc	<b>57kW (78)PS</b>	<b>TD21699</b>
<b>199 A1.000</b>	4 Cyl.		1368cc	<b>57kW (78)PS</b>	<b>TD25104</b>

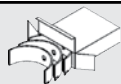
			
	<b>08-436800-00</b> STD <b>08-436806-00</b> 0.40mm  1.00  NT [15] 1.20  P 2.00  CR P  		

[15] Steel      [15] Acier      [15] Acciaio      [15] Acero

										
BE/PL	4	41.988/42.008	45.127/45.140	19.000	1.548	0.023/0.081	AL-LF	4275RA	<b>01-4154/4</b> STD 0.25 0.50	
MB/HL 3	2	52.000/52.200	68.766/69.020		2.325		AL-LF	04-4076	<b>H1092/5</b> STD 0.25 0.50	
MB/HL 1-5	10	47.980/48.000	51.705/51.718	19.000	1.848	0.020/0.067	AL-LF	4276RA		

		
<b>EE5242</b>	<b>HR397</b>	<b>NA5057</b>  27.00x37.00x7.00mm, FPM <b>LK5001</b>  [19] 74.00x187.50x17.000mm, FPM

[19] Specification: Oil Seal in housing      [19] Caractéristiques: Bague d'étanchéité dans son logement      [19] Specifiche: Paraolio in sede      [19] Especificaciones: Retén de aceite de la carcasa

# FIAT GROUP

<b>818</b>	<b>72.00</b>	<b>Petrol</b>							
<b>199 A6.000</b>	4 Cyl.	11:1	1368cc	<b>70-71kW (95-97)PS</b>				<b>TD20929</b>	<b>73</b>
<b>199 A6.000</b>	4 Cyl.	11:1	1368cc	<b>70kW (95)PS</b>				<b>TD23447</b>	<b>72</b>
<b>843 A1.000</b>	4 Cyl.	10.8:1	1368cc	<b>66-70kW (90-95)PS</b>				<b>TD17978</b>	<b>77</b>

	<b>08-433200-00</b> STD <b>08-433206-00</b> 0.40mm  1.00  NT [15] 1.20  P 2.00  P		

[15] Steel      [15] Acier      [15] Acciaio      [15] Acero

BE/PL 4 41.988/42.008	MB/HL 3 2 52.000/52.200	MB/HL 1-5 10 47.980/48.000	45.127/45.140	19.000	1.548	0.023/0.081	AL-LF	4275RA	<b>01-4154/4</b> STD 0.25 0.50 <b>H1092/5</b> STD 0.25 0.50
			68.766/69.020		2.325		AL-LF	04-4076	
			51.705/51.718	19.000	1.848	0.020/0.067	AL-LF	4276RA	

<b>EE5180</b>	<b>HR397</b>	<b>NA5057</b> 27.00x37.00x7.00mm, FPM <b>LK5001</b> [19] 74.00x187.50x17.000mm, FPM

[19] Specification: Oil Seal in housing      [19] Caractéristiques: Bague d'étanchéité dans son logement      [19] Specifiche: Paraolio in sede      [19] Especificaciones: Retén de aceite de la carcasa



<b>819</b>	<b>72.00</b>	<b>Petrol</b>							
<b>199 A7.000</b>	4 Cyl.	11:1	1368cc	<b>55kW (75)PS</b>				<b>TD23572</b>	<b>74</b>



	<b>08-436800-00</b> STD <b>08-436806-00</b> 0.40mm  1.00  NT [15] 1.20  P 2.00  CR P  		



[15] Steel      [15] Acier      [15] Acciaio      [15] Acero









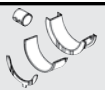

BE/PL 4 41.988/42.008	MB/HL 3 2 52.000/52.200	MB/HL 1-5 10 47.980/48.000	45.127/45.140	19.000	1.548	0.023/0.081	AL-LF	4275RA	<b>01-4154/4</b> STD 0.25 0.50 <b>H1092/5</b> STD 0.25 0.50
			68.766/69.020		2.325		AL-LF	04-4076	
			51.705/51.718	19.000	1.848	0.020/0.067	AL-LF	4276RA	





<b>EE5180</b>	<b>HR397</b>	<b>NA5057</b> 27.00x37.00x7.00mm, FPM <b>NA5061</b> 74.00x88.00x8.00mm, FPM



<b>820</b>			<b>Petrol</b>			
310 A2.011	4 Cyl.	10.4:1	1368cc	60-63kW (82-86)PS		TD24631
940 A2.000 Euro 5	4 Cyl.	9.8:1	1368cc	125kW (170)PS	Turbo Intercooled	TD23920 <b>78</b>
955 A7.000	4 Cyl.	9.8:1	1368cc	99kW (135)PS	Turbocharged	TD24940 <b>78</b>
955 A8.000 Euro 5	4 Cyl.	9.8:1	1368cc	120-132kW (163-180)PS	Turbocharged	TD24767 <b>79</b>
955 A8.000 Euro 5	4 Cyl.	9.8:1	1368cc	120kW (163)PS	Turbocharged	TD24589 <b>78</b>





		
[19] Specification: Oil Seal in housing	[19] Caractéristiques: Bague d'étanchéité dans son logement	[19] Specifiche: Paraolio in sede
		[19] Especificaciones: Retén de aceite de la carcasa



<b>821</b>			<b>Petrol</b>			
312 A1.000	4 Cyl.	9.8:1	1368cc	99-140kW (135-190)PS	Turbo Intercooled	TD21036 <b>75</b>
955 A2.000 Euro 5	4 Cyl.	9.8:1	1368cc	99kW (135)PS		TD23576 <b>79</b>
955 A2.000 Euro 5	4 Cyl.	9.8:1	1368cc	99kW (135)PS		TD24588 <b>78</b>
955 A6.000 Euro 5	4 Cyl.	10.8:1	1368cc	77kW (105)PS		TD23577 <b>79</b>
955 A6.000 Euro 5	4 Cyl.	10.8:1	1368cc	77kW (105)PS		TD24587 <b>81</b>









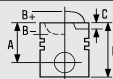

										
BE/PL	4	41.988/42.008	45.127/45.140	19.000	1.548	0.023/0.081	AL-LF	4275RA	01-4154/4 STD 0.25 0.50	
MB/HL 3	2	52.000/52.200	68.766/69.020		2.325		AL-LF	04-4076	H1092/5 STD 0.25 0.50	
MB/HL 1-5	10	47.980/48.000	51.705/51.718	19.000	1.848	0.020/0.067	AL-LF	4276RA		





		
[19] Specification: Oil Seal in housing	[19] Caractéristiques: Bague d'étanchéité dans son logement	[19] Specifiche: Paraolio in sede
	HR397	[19] Especificaciones: Retén de aceite de la carcasa
		NA5057  27.00x37.00x7.00mm, FPM
		LK5001  [19] 74.00x187.50x17.000mm, FPM



<b>822</b>			<b>Petrol</b>			
312 A3.000	4 Cyl.	9.8:1	1368cc	103-132kW (140-180)PS	Turbo Intercooled	TD24772 <b>68</b>





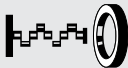
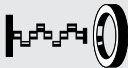
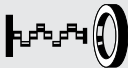



		
[19] Specification: Oil Seal in housing	[19] Caractéristiques: Bague d'étanchéité dans son logement	[19] Specifiche: Paraolio in sede
	HR397	[19] Especificaciones: Retén de aceite de la carcasa
		NA5057  27.00x37.00x7.00mm, FPM
		LK5001  [19] 74.00x187.50x17.000mm, FPM

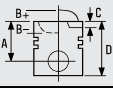
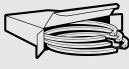

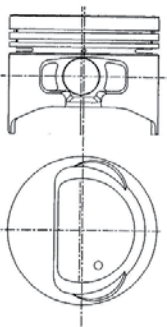







<b>823</b>			<b>Petrol</b>			
323 B6.600	4 Cyl.	10.8:1	1368cc	66-84kW (90-114)PS		TD24955

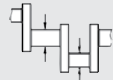

						
[15] Steel	[15] Acier	[15] Acciaio	[15] Acero			
				08-433200-00 STD		
				08-433206-00 0.40mm		
				1.00  NT [15]		
				1.20  P		
				2.00  P		



<b>824</b>	 <b>72.00</b>	<b>Petrol</b>			
<b>327 A.011</b>	4 Cyl.	12.35:1	1368cc	<b>62-66kW (85-90)PS</b>	<b>TD24641</b>
					
	<b>HR397</b>	<b>NA5057</b>  27.00x37.00x7.00mm, FPM <b>NA5061</b>  74.00x88.00x8.00mm, FPM			





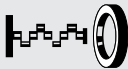
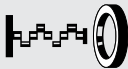
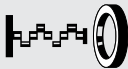

<b>825</b>	 <b>72.00</b>	<b>Petrol</b>			
<b>350 A1.000</b>	4 Cyl.	11:1	1368cc	<b>55-57kW (75-78)PS</b>	<b>TD20274</b> <b>76</b>
<b>350 A1.000 Euro4/Euro5</b>	4 Cyl.	11.7:1	1368cc	<b>57kW (78)PS</b>	<b>TD26416</b> <b>74</b>
<b>350 A1.000 Euro4/Euro5</b>	4 Cyl.	11:1	1368cc	<b>51-57kW (69-78)PS</b>	<b>TD20248</b> <b>76</b>

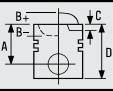
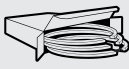

			
<b>87-436800-00</b> STD <b>87-436806-00</b> 0.40mm 	<b>08-436800-00</b> STD <b>08-436806-00</b> 0.40mm  NT [15]  P  CR P 		
<b>A</b> 26.00 <b>B-</b> 4.75 <b>C</b> 2.05 <b>D</b> 49.00  18x49			
[15] Steel	[15] Acier	[15] Acciaio	[15] Acero

									
BE/PL	4	41.988/42.008	45.127/45.140	19.000	1.548	0.023/0.081	AL-LF	4275RA	<b>01-4154/4</b> STD 0.25 0.50
MB/HL 3	2	52.000/52.200	68.766/69.020		2.325		AL-LF	04-4076	<b>H1092/5</b> STD 0.25 0.50
MB/HL 1-5	10	47.980/48.000	51.705/51.718	19.000	1.848	0.020/0.067	AL-LF	4276RA	

		
<b>EE5242</b>	<b>HR397</b>	<b>NA5057</b>  27.00x37.00x7.00mm, FPM <b>NA5061</b>  74.00x88.00x8.00mm, FPM

<b>826</b>	 <b>72.00</b>	<b>Petrol</b>			
<b>834 A1.000</b>	4 Cyl.	11:1	1368cc	<b>70kW (95)PS</b>	<b>TD23867</b> <b>71</b>

			
	<b>08-138200-00</b> STD  1.19 NT P  1.20 P  1.50 CR P		

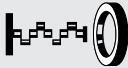
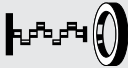
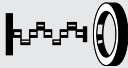

		
		<b>NB815</b>  23.00x35.00x7.00mm, FPM <b>LK5001</b>  [19] 74.00x187.50x17.000mm, FPM

[19] Specification: Oil Seal in housing





[19] Caractéristiques: Bague d'étanchéité dans son logement

[19] Specifiche: Paraolio in sede



[19] Especificaciones: Retén de aceite de la carcasa

**827**  **72.00** **Petrol** 











**940 A6.000 Euro 5** 4 Cyl. 9.8:1 1368cc **85kW (116)PS** **Turbo Intercooled** **TD24794** **79**

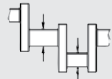

		
<b>EE5242</b>		<b>NA5057</b>  27.00x37.00x7.00mm, FPM <b>LK5001</b>  [19] 74.00x187.50x17.000mm, FPM

[19] Specification: Oil Seal in housing      [19] Caractéristiques: Bague d'étanchéité dans son logement      [19] Specifiche: Paraolio in sede      [19] Especificaciones: Retén de aceite de la carcasa

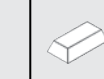

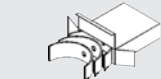



**828**  **72.00** **Petrol** 

**940 B1.000** 4 Cyl. 1368cc **77kW (105)PS** **TD26994** **80**

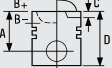
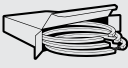







											
BE/PL	4	41.990/42.008	45.128/45.138	19.000	1.548	0.024/0.068	AL-LF	01-4079	<b>01-4079/4</b> STD		
MB/HL 3	2	52.000/52.200	68.766/69.020		2.325		AL-LF	04-4076	<b>H1092/5</b> STD 0.25 0.50		
MB/HL 1-5	10	47.980/48.000	51.705/51.718	19.000	1.848	0.020/0.067	AL-LF	4276RA			
SE/PB	1	17.970/17.974	20.775/20.800	22.000			BS-LF	55-4078	<b>55-4078</b> SEMI		



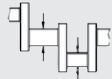
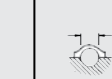

**829**  **72.00** **Petrol** 

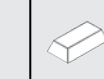
**955 A9.000** 4 Cyl. 11.1:1 1368cc **51kW (69)PS** **TD26417** **82**

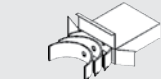
			
	<b>08-436800-00</b> STD <b>08-436806-00</b> 0.40mm		
	1.00  NT [15] 1.20  P 2.00  CR P		
			

[15] Steel      [15] Acier      [15] Acciaio      [15] Acero

											
BE/PL	4	41.990/42.008	45.128/45.138	19.000	1.548	0.024/0.068	AL-LF	01-4079	<b>01-4079/4</b> STD		
MB/HL 3	2	52.000/52.200	68.766/69.020		2.325		AL-LF	04-4076	<b>H1092/5</b> STD 0.25 0.50		
MB/HL 1-5	10	47.980/48.000	51.705/51.718	19.000	1.848	0.020/0.067	AL-LF	4276RA			

		
		<b>NA5057</b>  27.00x37.00x7.00mm, FPM <b>LK5001</b>  [19] 74.00x187.50x17.000mm, FPM

[19] Specification: Oil Seal in housing      [19] Caractéristiques: Bague d'étanchéité dans son logement      [19] Specifiche: Paraolio in sede      [19] Especificaciones: Retén de aceite de la carcasa

# FIAT GROUP

## 830

73.00

Petrol



124 BL.016

4 Cyl.

8.8:1

1197cc

34-44kW (46-60)PS

TD21452

BE/PL	4	45.508/45.528	48.629/48.646	19.200	1.547	0.020/0.069	AL-LF	1645RA	<b>01-4127/4</b> STD 0.25 0.50
BE/PL	4	45.508/45.528	48.629/48.646	19.200	1.538	0.025/0.087	AL-LF	60985RA	<b>01-4171/4</b> STD

1645RA

60985RA

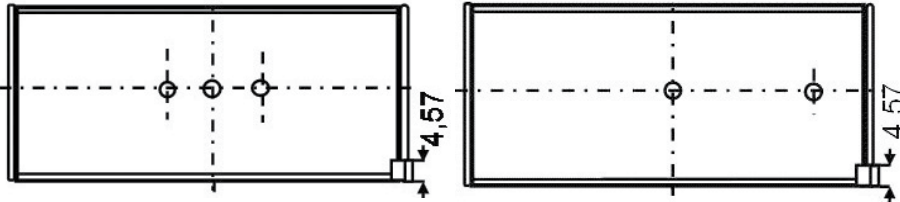

MB/HL 1,2,4,5	4	50.785/50.805	54.507/54.520	20.250	1.831	0.040/0.098	AL-LF	60986RA	<b>H1028/5</b> STD 0.25
MB/HL 3	1	50.785/50.805	54.507/54.520	22.750	1.831	0.040/0.098	AL-LF	60987RA	
TW/A	2	56.610/56.684	69.596/69.850		2.362		AL-LF	60987AF	<b>A197/2</b> STD .005
TW/A	2	56.610/56.864	69.596/69.850		2.362		AL-LF	60987AFA	<b>A198/2</b> STD .005

60987AF

60987AFA

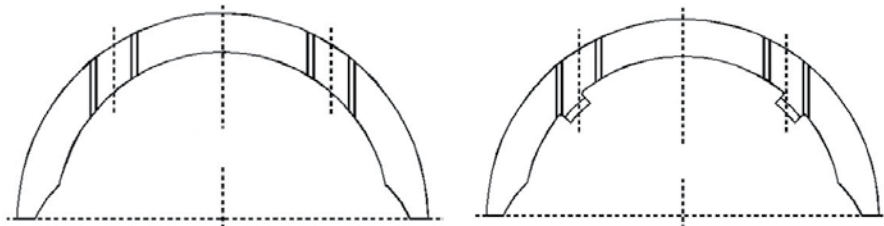

SE/PB	1	21.539/21.641	23.939/23.972	25.100			BS	62039Y	<b>55-4288</b> SEMI
-------	---	---------------	---------------	--------	--	--	----	--------	------------------------

## 831

73.50

Petrol



126 A.000

2 Cyl.

7.5:1

594cc

17kW (23)PS

TD880

83

<p><b>87-528400-00</b> STD</p> <p><b>87-528406-00</b> 0.40mm</p> <p><b>87-528408-00</b> 0.60mm</p> <p><b>A</b> 40.00</p> <p><b>D</b> 79.50</p> <p> 20x61</p>	<p><b>08-528400-00</b> STD</p> <p><b>08-528406-00</b> 0.40mm</p> <p><b>08-528408-00</b> 0.60mm</p> <p>1.50  CR P</p> <p>2.00  P</p> <p>3.95  P</p>	<p>[10]</p> <p><b>B</b> 81.50 <b>C</b> 130.40 <b>E</b> 79.90</p>	<p><b>88-528400-00</b></p>













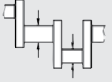
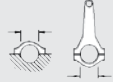

[10] Liner available in Kit Set only

[10] Chemise disponible en kit seulment

[10] Cilindro disponibile solo in kit motore

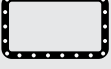
[10] Camisas disponible en conjuntos solamente.













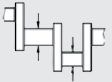
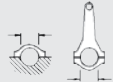

...Continued

<b>831</b>		 <b>73.50</b>	<b>Petrol</b>								
											
BE/PL	2	44.013/44.033	47.130/47.142	19.200	1.543	0.011/0.068	AL-LF	60005RA	01-4112/2 STD 0.25 0.50		
SE/PB	1	19.507/19.609	22.009/22.034	20.830			BS	60009X	55-4210 SEMI		
											
			<b>JH310</b> 				<b>NA5045</b>  53.00x68.00x10.00mm, ACM				
			<b>JH310</b>								

<b>832</b>		 <b>73.50</b>	<b>Petrol</b>							
<b>126 AB.0C.0</b>		2 Cyl.	7.5:1	594cc	<b>17kW (23)PS</b>				<b>TD22224</b>	
<b>126 AB.5C.0</b>		2 Cyl.	7.5:1	594cc	<b>13kW (18)PS</b>				<b>TD22225</b>	

										
BE/PL	2	44.013/44.033	47.130/47.142	19.200	1.543	0.011/0.068	AL-LF	60005RA	01-4112/2 STD 0.25 0.50	
SE/PB	1	19.507/19.609	22.009/22.034	20.830			BS	60009X	55-4210 SEMI	









<b>833</b>		 <b>74.00</b>	<b>Petrol</b>							
<b>AR 00500</b>		4 Cyl.		1290cc	<b>37kW (50)PS</b>				<b>TD21701</b>	
<b>AR 00501</b>		4 Cyl.		1290cc	<b>48kW (65)PS</b>				<b>TD21702</b>	
<b>AR 00502</b>		4 Cyl.		1290cc	<b>46-55kW (63-75)PS</b>				<b>TD21704</b>	
<b>AR 00504</b>		4 Cyl.		1290cc	<b>39kW (53)PS</b>				<b>TD21705</b>	
<b>AR 00508</b>		4 Cyl.	9:1	1290cc	<b>59kW (80)PS</b>				<b>TD21709</b>	
<b>AR 00510</b>		4 Cyl.		1290cc	<b>66kW (90)PS</b>				<b>TD21711</b>	
<b>AR 00514</b>		4 Cyl.		1290cc	<b>74kW (101)PS</b>				<b>TD21712</b>	

											
BE/PL	4	44.963/44.975	48.658/48.671	23.440	1.829	0.025/0.075	AL-LF	2650RA	01-4307/4 0.25		
MB/HL 1,3,5	3	59.960/59.973	63.657/63.676	25.530	1.837	0.020/0.067	BS	60011CP	H1030/5 STD 0.25 0.50		
MB/HL 2,4	2	59.960/59.973	63.657/63.676	18.360	1.837	0.020/0.067	BS	60012CP			
TW/A	4	65.786/66.040	82.423/82.677		2.362		AL-LF	2777AF	A178/4 STD		
SE/PB	1	21.994/22.000	25.120/25.146	23.720			BS	60014X	55-4280 SEMI		
											
							<b>NA5066</b>  35.00x50.00x10.00mm, ACM				

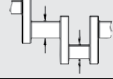
# FIAT GROUP



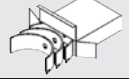

## 834 74.00 Petrol

AR 00506 4 Cyl. 9:1 1290cc 57kW (78)PS TD26425



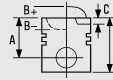
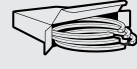



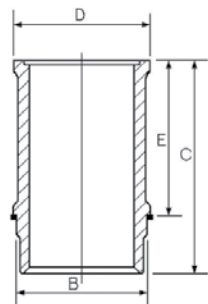

									
BE/PL	4	44.963/44.975	48.658/48.671	23.440	1.829	0.025/0.075	AL-LF	2650RA	<b>01-4307/4</b> 0.25
MB/HL 1,3,5	3	59.960/59.973	63.657/63.676	25.530	1.837	0.020/0.067	BS	60011CP	<b>H1030/5</b> STD 0.25 0.50
MB/HL 2,4	2	59.960/59.973	63.657/63.676	18.360	1.837	0.020/0.067	BS	60012CP	
TW/A	4	65.786/66.040	82.423/82.677		2.362		AL-LF	2777AF	<b>A178/4</b> STD
SE/PB	1	21.994/22.000	25.120/25.146	23.720			BS	60014X	<b>55-4280</b> SEMI

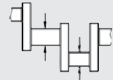

## 835 74.00 Petrol

AR 00530 4 Cyl. 1290cc 64-65kW (87-89)PS TD23 84

			
<b>87-530400-00</b> STD  A 32.50 B- 13.60 D 79.10  20x64	<b>08-530400-00</b> STD  1.50 1.75 4.00 	<b>15-632500-00</b> [9] B 80.50 C 139.00 D 90.00 E 89.20 	<b>89-530400-00</b> 87-530400-00 + 15-632500-00

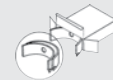
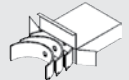

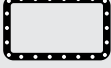
[9] Includes seals [9] Inclut des joints [9] Comprende le guarnizioni [9] Incluye los sellos

									
BE/PL	4	44.963/44.975	48.658/48.671	23.440	1.829	0.025/0.075	AL-LF	2650RA	<b>01-4307/4</b> 0.25
MB/HL 1,3,5	3	59.960/59.973	63.657/63.676	25.530	1.837	0.020/0.067	BS	60011CP	<b>H1030/5</b> STD 0.25 0.50
MB/HL 2,4	2	59.960/59.973	63.657/63.676	18.360	1.837	0.020/0.067	BS	60012CP	
TW/A	4	65.786/66.040	82.423/82.677		2.362		AL-LF	2777AF	<b>A178/4</b> STD
SE/PB	1	21.994/22.000	25.120/25.146	23.720			BS	60014X	<b>55-4280</b> SEMI



		
<b>NA5066</b>  35.00x50.00x10.00mm, ACM		

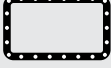







## 836 74.00 Petrol

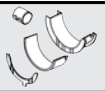

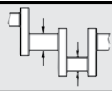
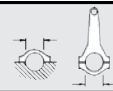

AR 10531 4 Cyl. 1290cc 81kW (110)PS TD21724  
AR 10534 4 Cyl. 1290cc 117kW (159)PS TD21725

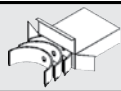

		
<b>NA5066</b>  35.00x50.00x10.00mm, ACM		



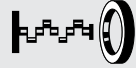







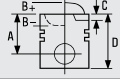
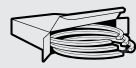

<b>837</b>		<b>75.00</b>	<b>Petrol</b>			
<b>KFT</b>	4 Cyl.	10.2:1	1360cc	<b>54kW (73)PS</b>	<b>TD24950</b>	<b>85</b>
<b>KFV</b>	4 Cyl.	10.5:1	1360cc	<b>54kW (73)PS</b>	<b>TD24771</b>	<b>85</b>

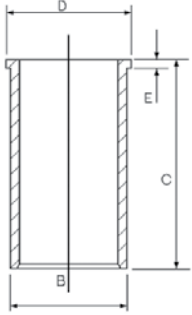

									
BE/PL	4	44.975/44.991	48.655/48.671	19.750	1.820	0.020/0.080	AL-LF	4650RA	<b>01-4163/4</b> STD 0.25
MB/HL 2-4	3	49.965/49.981	53.655/53.674	17.290	1.832	0.020/0.070	AL-LF	1261RA	<b>H1071/5</b> STD 0.30 0.50
MB/HL 1,5	2	49.965/49.981	53.655/53.674	17.290	1.832	0.020/0.070	AL-LF	1262RA	
TW/A	2	55.250/55.500	71.450/71.700		2.450		BS	62047BFA	<b>A203/2</b> STD 0.10



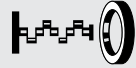



		
		<b>NF870</b>  42.00x66.00x6.00mm, FPM/ACM
		<b>NF857</b>  85.00x105.00x9.00mm, FPM/ACM

<b>838</b>		<b>75.00</b>	<b>Diesel</b>				
<b>9HU</b>	4 Cyl.	18:1	1560cc	<b>66kW (90)PS</b>	<b>Turbo Intercooled</b>	<b>TD24776</b>	<b>86</b>

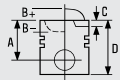
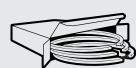

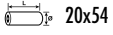
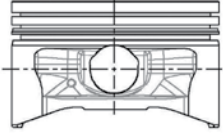



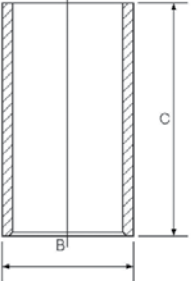



			
	<b>08-424000-00</b> STD <b>08-424007-00</b> 0.50mm <b>08-424008-00</b> 0.60mm  3.00  CK P 1.95  P 2.50  CR P  	<b>14-020900-00 D</b> <b>B 78.00 C 142.00 D 79.50 F 5.00</b>  	

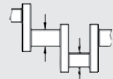



		
<b>ED5130</b>	<b>HR397</b>	<b>NA5325</b>  85.00x105.00x8.80mm, PTFE

<b>839</b>		<b>76.00</b>	<b>Petrol</b>		
<b>127 A.000</b>	4 Cyl.	1049cc	<b>37-41kW (50-56)PS</b>	<b>TD887</b>	<b>88</b>

			
<b>87-209800-00</b> STD <b>87-209806-00</b> 0.40mm <b>87-209808-00</b> 0.60mm  <b>A 30.75</b> <b>D 61.25</b>  20x54  	<b>08-209800-00</b> STD <b>08-209806-00</b> 0.40mm <b>08-209808-00</b> 0.60mm  1.75  CR P 2.00  P 3.95  P	<b>14-011001-00 D</b> <b>B 68.04 C 115.00</b>  	







**839**  **76.00** **Petrol**

									
BE/PL	4	39.985/40.005	43.657/43.670	16.550	1.813	0.026/0.084	AL-LF	3025RA	<b>01-4139/4</b> STD 0.25 0.50
MB/HL 1,3	2	50.785/50.805	54.507/54.520	20.620	1.837	0.028/0.086	AL-LF	62006RA	<b>H1039/3</b> STD 0.25 0.50
MB/HL 2	1	50.790/50.810	54.507/54.520	22.780	1.837	0.028/0.086	AL-LF	62007RA	
TW/A	2	54.610/54.864	69.596/69.850		2.362		AL-LF	2897AFF	<b>A182/2</b> STD

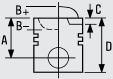







		
	HC027 	NB808  64.00x80.00x8.00mm, FPM
	HC027	

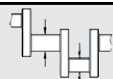

**840**  **76.00** **Petrol** 





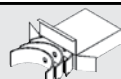



<b>127 A1.000</b>	4 Cyl.	1049cc	<b>51kW (70)PS</b>	<b>TD4345</b>	<b>89</b>
<b>127 A6.000</b>	4 Cyl.	1049cc	<b>44kW (60)PS</b>	<b>TD4347</b>	<b>90</b>



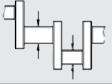
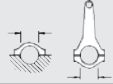

			
	<b>08-269700-00</b> STD <b>08-269704-00</b> 0.20mm <b>08-269706-00</b> 0.40mm <b>08-269710-00</b> 0.80mm  1.50  CR P 2.00  P 3.95  CR [15]		

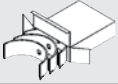

[15] Steel      [15] Acier      [15] Acciaio      [15] Acero











									
BE/PL	4	43.988/44.008	47.130/47.142	18.500	1.546	0.030/0.087	AL-LF	68090RA	<b>01-4207/4</b> STD 0.25 0.50
MB/HL 1,2,4,5	4	48.189/48.209	51.921/51.934	17.650	1.841	0.030/0.088	AL-LF	68091RA	<b>H1069/5</b> STD 0.25 0.50
MB/HL 3	1	48.189/48.209	51.921/51.934	25.250	1.841	0.030/0.088	AL-LF	68092RA	
TW/A	2	54.224/54.478	66.996/67.520		2.362		AL-LF	68092AF	<b>A221/2</b> STD
SE/PB	1	21.539/21.641	23.939/23.972	25.100			BS	62039Y	<b>55-4288</b> SEMI

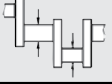
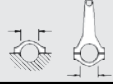

<b>841</b>	 <b>76.00</b>	<b>Petrol</b>					
<b>146 A 5.046</b>	4 Cyl.	9:1	1297cc	<b>53kW (72)PS</b>	<b>TD4591</b>	<b>93</b>	
<b>156 A1.000</b>	4 Cyl.	7:1	1049cc	<b>62kW (84)PS</b>	<b>Turbo Intercooled</b>	<b>TD1783</b>	<b>91</b>







										
BE/PL	4	43.988/44.008	47.130/47.142	18.500	1.546	0.030/0.087	AL-LF	68090RA	<b>01-4207/4</b> STD 0.25 0.50	
MB/HL 1,2,4,5	4	48.189/48.209	51.921/51.934	17.650	1.841	0.030/0.088	AL-LF	68091RA	<b>H1069/5</b> STD 0.25 0.50	
MB/HL 3	1	48.189/48.209	51.921/51.934	25.250	1.841	0.030/0.088	AL-LF	68092RA		
TW/A	2	54.224/54.478	66.996/67.520		2.362		AL-LF	68092AF	<b>A221/2</b> STD	
SE/PB	1	21.539/21.641	23.939/23.972	25.100			BS	62039Y	<b>55-4288</b> SEMI	

		
JJ078		
		
JJ078		

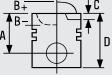
<b>842</b>	 <b>76.00</b>	<b>Petrol</b>			
<b>131 A.000</b>	4 Cyl.	8:1	1297cc	<b>48kW (65)PS</b>	<b>TD26093</b>

										
BE/PL	4	48.224/48.244	51.330/51.346	19.500	1.540	0.020/0.067	AL-LF	66315RA	<b>01-4176/4</b> STD 0.25 0.50	
MB/HL 1,2,4,5	4	52.985/53.005	56.717/56.730	20.750	1.841	0.030/0.088	AL-LF	66316RA	<b>H1043/5</b> STD 0.25 0.50 0.75	
MB/HL 3	1	52.985/53.005	56.717/56.730	24.250	1.841	0.030/0.088	AL-LF	66317RA		
TW/A	2	59.000/59.250	73.600/73.850		2.362		BS	62037AF	<b>A201/2</b> STD .005	
SE/PB	1	21.539/21.641	23.939/23.972	25.100			BS	62039Y	<b>55-4288</b> SEMI	











<b>843</b>	 <b>76.00</b>	<b>Petrol</b>				
<b>131 A6.000</b>	4 Cyl.		1297cc	<b>40kW (54)PS</b>	<b>TD897</b>	<b>92</b>
<b>131 B.000</b>	4 Cyl.	8.9:1	1297cc	<b>57-60kW (78-82)PS</b>	<b>TD899</b>	

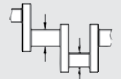

			
	<b>08-269700-00</b> STD <b>08-269704-00</b> 0.20mm <b>08-269706-00</b> 0.40mm <b>08-269710-00</b> 0.80mm  1.50  CR P 2.00  P 3.95  CR [15]		







[15] Steel      [15] Acier      [15] Acciaio      [15] Acero



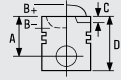
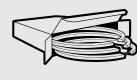







# FIAT GROUP

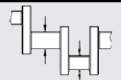



...Continued



<b>843</b>		 <b>76.00</b>	<b>Petrol</b>						
									
BE/PL	4	48.224/48.244	51.330/51.346	19.500	1.540	0.020/0.067	AL-LF	66315RA	<b>01-4176/4</b> STD 0.25 0.50
MB/HL 1,2,4,5	4	52.985/53.005	56.717/56.730	20.750	1.841	0.030/0.088	AL-LF	66316RA	<b>H1043/5</b> STD 0.25 0.50 0.75
MB/HL 3	1	52.985/53.005	56.717/56.730	24.250	1.841	0.030/0.088	AL-LF	66317RA	
TW/A	2	59.000/59.250	73.600/73.850		2.362		BS	62037AF	<b>A201/2</b> STD .005
SE/PB	1	21.539/21.641	23.939/23.972	25.100			BS	62039Y	<b>55-4288</b> SEMI







<b>844</b>		 <b>76.00</b>	<b>Petrol</b>							
<b>127 A3.000</b>		4 Cyl.	130lcc	<b>55kW (75)PS</b>			<b>TD4415</b>		<b>100</b>	



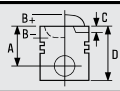
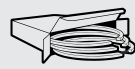





			
	<b>08-269700-00</b> STD <b>08-269704-00</b> 0.20mm <b>08-269706-00</b> 0.40mm <b>08-269710-00</b> 0.80mm  1.50  CR P 2.00  P 3.95  CR [15]		
[15] Steel	[15] Acier	[15] Acciaio	[15] Acero



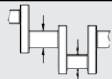
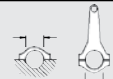



									
BE/PL	4	43.988/44.008	47.130/47.142	18.500	1.546	0.030/0.087	AL-LF	68090RA	<b>01-4207/4</b> STD 0.25 0.50
MB/HL 1,2,4,5	4	48.189/48.209	51.921/51.934	17.650	1.841	0.030/0.088	AL-LF	68091RA	<b>H1069/5</b> STD 0.25 0.50
MB/HL 3	1	48.189/48.209	51.921/51.934	25.250	1.841	0.030/0.088	AL-LF	68092RA	
TW/A	2	54.224/54.478	66.996/67.520		2.362		AL-LF	68092AF	<b>A221/2</b> STD
SE/PB	1	21.539/21.641	23.939/23.972	25.100			BS	62039Y	<b>55-4288</b> SEMI

		
	JJ078 	
	JJ078	

<b>845</b>	 <b>76.00</b>	<b>Diesel</b>	
<b>146 B1.000</b>	4 Cyl.	1301cc	<b>33kW (45)PS</b>
<b>156 A5.000</b>	4 Cyl.	20:1	<b>27kW (37)PS</b>
			<b>TD948 94</b>
			<b>TD999 96</b>

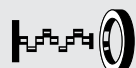
				<b>08-215200-10</b> STD <b>08-215206-10</b> 0.40mm <b>08-215208-10</b> 0.60mm <b>08-215211-10</b> 1.00mm	<b>14-021260-00 D</b> <b>B 80.00 C 133.50 D 81.00 E 5.00</b>
				2.50  CR P 2.00  P 3.00  CR P	<b>14-012470-00 D</b> <b>B 79.00 C 139.00</b>

									
BE/PL	4	43.988/44.008	47.130/47.142	18.500	1.546	0.030/0.087	AL-LF	68090RA	<b>01-4207/4</b> STD 0.25 0.50
MB/HL 1,2,4,5	4	48.189/48.209	51.921/51.934	17.650	1.841	0.030/0.088	AL-LF	68091RA	<b>H1069/5</b> STD 0.25 0.50
MB/HL 3	1	48.189/48.209	51.921/51.934	25.250	1.841	0.030/0.088	AL-LF	68092RA	
TW/A	2	54.224/54.478	66.996/67.520		2.362		AL-LF	68092AF	<b>A221/2</b> STD

		
	<b>JJ078</b>	<b>NA5051</b>  40.00x56.00x7.00mm, FPM <b>NA5052</b>  70.00x85.00x8.00mm, FPM
		
	<b>JJ078</b>	

## 846

 76.00

**Diesel**



127 A5.000

4 Cyl.

20:1

1302cc

33kW (45)PS

TD4346

95

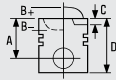

87-215200-00  
87-215208-00

STD  
0.60mm



A 46.95  
B+ 4.90  
D 83.85  
 22x64

RT

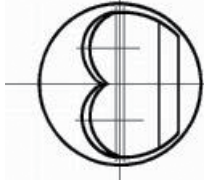

08-215200-10 STD  
08-215206-10 0.40mm  
08-215208-10 0.60mm  
08-215211-10 1.00mm

2.50  CR P  
2.00  P  
3.00  CR P





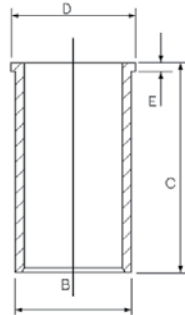



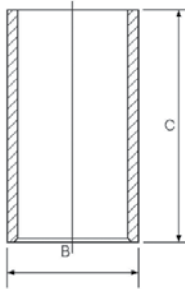

14-021260-00 D  
B 80.00 C 133.50 D 81.00 E 5.00

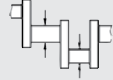

14-012470-00 D  
B 79.00 C 139.00



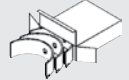

									
BE/PL	4	43.988/44.008	47.130/47.142	18.500	1.546	0.030/0.087	AL-LF	68090RA	<b>01-4207/4</b> STD 0.25 0.50 <b>H1069/5</b> STD 0.25 0.50 <b>A221/2</b> STD
MB/HL 1,2,4,5	4	48.189/48.209	51.921/51.934	17.650	1.841	0.030/0.088	AL-LF	68091RA	
MB/HL 3	1	48.189/48.209	51.921/51.934	25.250	1.841	0.030/0.088	AL-LF	68092RA	
TW/A	2	54.224/54.478	66.996/67.520		2.362		AL-LF	68092AF	





JJ440













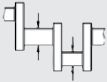
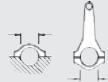



JJ440



NA5051  40.00x56.00x7.00mm, FPM  
NA5052  70.00x85.00x8.00mm, FPM

**847**  **76.00** **Petrol** 

**146 A2.166** 4 Cyl. 994cc **35kW (48)PS** **TD19059** **97**









									
BE/PL	4	43.988/44.008	47.130/47.142	18.500	1.546	0.030/0.087	AL-LF	68090RA	<b>01-4207/4</b> STD 0.25 0.50
MB/HL 1,2,4,5	4	48.189/48.209	51.921/51.934	17.650	1.841	0.030/0.088	AL-LF	68091RA	<b>H1069/5</b> STD 0.25 0.50
MB/HL 3	1	48.189/48.209	51.921/51.934	25.250	1.841	0.030/0.088	AL-LF	68092RA	
TW/A	2	54.224/54.478	66.996/67.520		2.362		AL-LF	68092AF	<b>A221/2</b> STD
SE/PB	1	21.539/21.641	23.939/23.972	25.100			BS	62039Y	<b>55-4288</b> SEMI

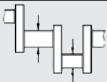
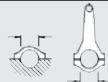

		
		<b>NB815</b>  23.00x35.00x7.00mm, FPM <b>NB814</b>  70.00x88.00x8.00mm, FPM

**848**  **76.10** **Petrol** 









**156 A.000** 4 Cyl. 9.5:1 1049cc **40-41kW (54-56)PS** **TD21222** **99**

**156 A.000** 4 Cyl. 9.5:1 1049cc **40-41kW (54-56)PS** **TD4411** **98**

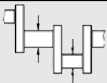
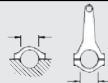
									
BE/PL	4	43.988/44.008	47.130/47.142	18.500	1.546	0.030/0.087	AL-LF	68090RA	<b>01-4207/4</b> STD 0.25 0.50
MB/HL 1,2,4,5	4	48.189/48.209	51.921/51.934	17.650	1.841	0.030/0.088	AL-LF	68091RA	<b>H1069/5</b> STD 0.25 0.50
MB/HL 3	1	48.189/48.209	51.921/51.934	25.250	1.841	0.030/0.088	AL-LF	68092RA	
TW/A	2	54.224/54.478	66.996/67.520		2.362		AL-LF	68092AF	<b>A221/2</b> STD
SE/PB	1	21.539/21.641	23.939/23.972	25.100			BS	62039Y	<b>55-4288</b> SEMI

**849**  **76.10** **Petrol** 

**156 B.000** 4 Cyl. 9.5:1 1301cc **53-56kW (72-76)PS** **TD1853** **101**

									
BE/PL	4	43.988/44.008	47.130/47.142	18.500	1.546	0.030/0.087	AL-LF	68090RA	<b>01-4207/4</b> STD 0.25 0.50
MB/HL 1,2,4,5	4	48.189/48.209	51.921/51.934	17.650	1.841	0.030/0.088	AL-LF	68091RA	<b>H1069/5</b> STD 0.25 0.50
MB/HL 3	1	48.189/48.209	51.921/51.934	25.250	1.841	0.030/0.088	AL-LF	68092RA	
TW/A	2	54.224/54.478	66.996/67.520		2.362		AL-LF	68092AF	<b>A221/2</b> STD
SE/PB	1	21.539/21.641	23.939/23.972	25.100			BS	62039Y	<b>55-4288</b> SEMI

**849**  **76.10** **Petrol**

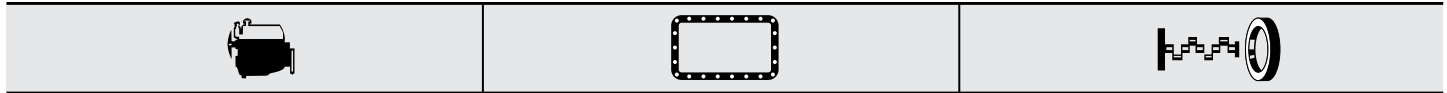







JJ078

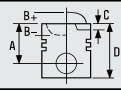
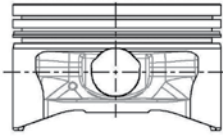
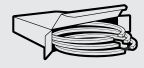
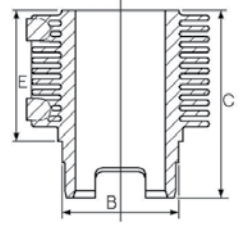

JJ078

**850**  **77.00** **Petrol** 

126 A1.000	2 Cyl.	652cc	17kW (23)PS	<b>TD4343</b>	<b>102</b>
126 A1.048	2 Cyl.	7.5:1	17-20kW (23-27)PS	<b>TD881</b>	<b>102</b>

				
<p><b>87-785500-00</b> STD  <b>87-785506-00</b> 0.40mm  <b>87-785508-00</b> 0.60mm</p> <p>A 40.00  D 79.50   20x61</p>	<p><b>08-785500-00</b> STD  <b>08-785506-00</b> 0.40mm  <b>08-785507-00</b> 0.50mm  <b>08-785508-00</b> 0.60mm</p> <p>1.50  CR P  2.00  P  3.95  CR [15]</p>	<p>[10]  <b>B 83.00 C 130.40 E 79.90</b></p>	<p><b>88-785500-00</b></p>	

[10] Liner available in Kit Set only  
[15] Steel

[10] Chemise disponible en kit seulement  
[15] Acier

[10] Cilindro disponibile solo in kit motore  
[15] Acciaio

[10] Camisas disponible en conjuntos solamente.  
[15] Acero

									
BE/PL	2	44.013/44.033	47.130/47.142	19.200	1.543	0.011/0.068	AL-LF	60005RA	<b>01-4112/2</b>
SE/PB	1	19.507/19.609	22.009/22.034	20.830			BS	60009X	STD 0.25 0.50 <b>55-4210</b> SEMI

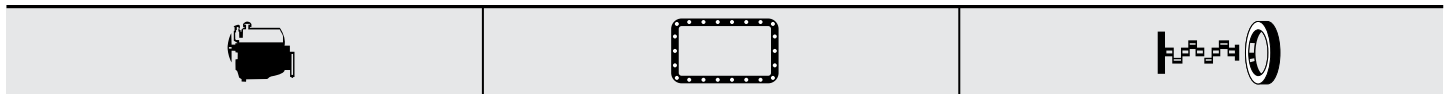



JH310









JH310

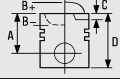
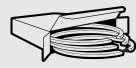







**NA5045**  53.00x68.00x10.00mm, ACM



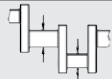
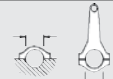





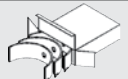

<b>851</b>	 <b>77.00</b>	<b>Petrol</b>				
<b>141 A.000</b>	2 Cyl.	8:1	652cc	<b>22kW (30)PS</b>	<b>TD9385</b>	<b>103</b>









			
	<b>08-785500-00</b> STD <b>08-785506-00</b> 0.40mm <b>08-785507-00</b> 0.50mm <b>08-785508-00</b> 0.60mm  1.50  CR P 2.00  P 3.95  CR [15]		

[15] Steel                      [15] Acier                      [15] Acciaio                      [15] Acero

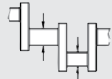
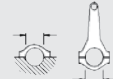
									
BE/PL	2	44.013/44.033	47.130/47.142	19.200	1.543	0.011/0.068	AL-LF	60005RA	<b>01-4112/2</b> STD 0.25 0.50
SE/PB	1	19.507/19.609	22.009/22.034	20.830			BS	60009X	<b>55-4210</b> SEMI

		
	<b>JH310</b>	<b>NA5049</b>  64.00x80.00x8.00mm, ACM <b>NB728</b>  53.00x68.00x10.00mm, ACM
		
	<b>JH310</b>	

<b>852</b>	 <b>78.00</b>	<b>Petrol</b>			
<b>131 C.000</b>	4 Cyl.	1367cc	<b>51kW (70)PS</b>	<b>TD902</b>	<b>104</b>
<b>131 C1.000</b>	4 Cyl.	1367cc	<b>51-55kW (69-75)PS</b>	<b>TD903</b>	<b>105</b>
<b>828 D3.000</b>	4 Cyl.	1367cc	<b>62kW (84)PS</b>	<b>TD1798</b>	

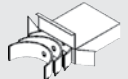
									
BE/PL	4	48.224/48.244	51.330/51.346	19.500	1.540	0.020/0.067	AL-LF	66315RA	<b>01-4176/4</b> STD 0.25 0.50
MB/HL 1,2,4,5	4	52.985/53.005	56.717/56.730	20.750	1.841	0.030/0.088	AL-LF	66316RA	<b>H1043/5</b> STD 0.25 0.50 0.75
MB/HL 3	1	52.985/53.005	56.717/56.730	24.250	1.841	0.030/0.088	AL-LF	66317RA	
TW/A	2	59.000/59.250	73.600/73.850		2.362		BS	62037AF	<b>A201/2</b> STD .005
SE/PB	1	21.539/21.641	23.939/23.972	25.100			BS	62039Y	<b>55-4288</b> SEMI

# FIAT GROUP

<b>853</b>	<b>78.00</b>	<b>Diesel</b>							
<b>146 B.000</b>	4 Cyl.	20:1	1367cc	<b>52kW (71)PS</b>	<b>Turbo Intercooled</b>	<b>TD947</b>	<b>106</b>		
<b>146 B3.000</b>	4 Cyl.	20:1	1367cc	<b>52kW (70)PS</b>	<b>Turbo Intercooled</b>	<b>TD950</b>	<b>106</b>		

	<b>08-783200-00</b> STD 2.50  MOL P 2.00  P 3.00  CR P	<b>14-021421-00 D</b> <b>B 81.06 C 130.00 D 83.50 E 4.50</b> 	

BE/PL	4	48.227/48.240	51.330/51.348	19.500	1.530	0.030/0.086	BS	1170CP	<b>71-4121/4</b> STD 0.25
MB/HL 1,2,4,5	4	52.990/53.010	56.717/56.735	20.750	1.843	0.020/0.080	BS	4128CP	<b>H1084/5</b> STD 0.25 0.50
MB/HL 3	1	52.990/53.010	56.717/56.735	24.250	1.843	0.020/0.080	BS	4129CP	
TW/A	2	59.000/59.250	73.600/73.850		2.362		BS	62037AF	<b>A201/2</b> STD .005









	<b>JJ298</b> (Cork) <b>JJ398</b>  JJ298                  JJ398	<b>NB742</b> 30.00x43.00x8.00mm, ACM <b>NA5050</b> 70.00x90.00x10.00mm, ACM



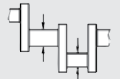
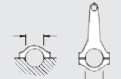

<b>854</b>	<b>78.00</b>	<b>Petrol</b>							
<b>AR 06100</b>	4 Cyl.		1567cc	<b>81kW (110)PS</b>					<b>TD47</b> <b>107</b>

<b>87-527200-00</b> STD A 33.70 B- 15.80 D 82.50 22x68	<b>08-527200-00</b> STD 1.50  CR P 1.75  P 4.00  P	[10] <b>B 84.00 C 150.00 D 94.00 E 95.50</b> 	<b>89-527200-00</b>









[10] Liner available in Kit Set only      [10] Chemise disponible en kit seulement      [10] Cilindro disponibile solo in kit motore      [10] Camisas disponible en conjuntos solamente.

...Continued

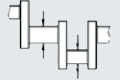
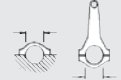
<b>854</b>		 <b>78.00</b>	<b>Petrol</b>						
									
BE/PL	4	49.988/49.998	53.695/53.708	23.440	1.838	0.021/0.069	BS	60010CP	<b>71-4168/4</b> STD 0.25 0.50
MB/HL 1,3,5	3	59.960/59.973	63.657/63.676	25.530	1.837	0.020/0.067	BS	60011CP	<b>H1030/5</b> STD 0.25 0.50
MB/HL 2,4	2	59.960/59.973	63.657/63.676	18.360	1.837	0.020/0.067	BS	60012CP	
TW/A	4	65.786/66.040	82.423/82.677		2.362		AL-LF	2777AF	<b>A178/4</b> STD
SE/PB	1	21.994/22.000	25.120/25.146	23.720			BS	60014X	<b>55-4280</b> SEMI

		
	<b>JJ452</b> (MVQ)	<b>NA5066</b>  35.00x50.00x10.00mm, ACM
		
	<b>JJ452</b>	

<b>855</b>		 <b>78.00</b>	<b>Petrol</b>						
<b>AR 00112</b>	4 Cyl.	9:1	1570cc	<b>67-68kW (91-92)PS</b>				<b>TD26422</b>	
<b>AR 00121</b>	4 Cyl.	9:1	1570cc	<b>82-83kW (112-113)PS</b>				<b>TD26423</b>	
<b>AR 00516</b>	4 Cyl.	9:1	1570cc	<b>82kW (112)PS</b>				<b>TD26424</b>	
<b>AR 11650</b>	4 Cyl.	9:1	1570cc	<b>80kW (109)PS</b>				<b>TD23341</b>	

									
BE/PL	4	49.988/49.998	53.695/53.708	23.440	1.838	0.021/0.069	BS	60010CP	<b>71-4168/4</b> STD 0.25 0.50
MB/HL 1,3,5	3	59.960/59.973	63.657/63.676	25.530	1.837	0.020/0.067	BS	60011CP	<b>H1030/5</b> STD 0.25 0.50
MB/HL 2,4	2	59.960/59.973	63.657/63.676	18.360	1.837	0.020/0.067	BS	60012CP	
TW/A	4	65.786/66.040	82.423/82.677		2.362		AL-LF	2777AF	<b>A178/4</b> STD
SE/PB	1	21.994/22.000	25.120/25.146	23.720			BS	60014X	<b>55-4280</b> SEMI

# FIAT GROUP

<b>856</b>	<b>78.00</b>	<b>Petrol</b>			
<b>AR 00526</b>	4 Cyl.	9:1	1570cc <b>71-81kW (97-110)PS</b>	<b>TD22</b>	<b>108</b>
<b>AR 00536</b>	4 Cyl.		<b>80kW (109)PS</b>	<b>TD24</b>	<b>109</b>
<b>AR 01600</b>	4 Cyl.		<b>79-80kW (108-109)PS</b>	<b>TD32</b>	<b>110</b>

<b>87-527200-00</b> STD <b>A</b> 33.70 <b>B-</b> 15.80 <b>D</b> 82.50 22x68	<b>08-527200-00</b> STD 1.50  CR P 1.75  P 4.00  P	[10] <b>B</b> 84.00 <b>C</b> 150.00 <b>D</b> 94.00 <b>E</b> 95.50 	<b>89-527200-00</b> 

[10] Liner available in Kit Set only      [10] Chemise disponible en kit seulement      [10] Cilindro disponibile solo in kit motore      [10] Camisas disponible en conjuntos solamente.



BE/PL	4	49.988/49.998	53.695/53.708	23.440	1.838	0.021/0.069	BS	60010CP	<b>71-4168/4</b> STD 0.25 0.50
MB/HL 1,3,5	3	59.960/59.973	63.657/63.676	25.530	1.837	0.020/0.067	BS	60011CP	<b>H1030/5</b> STD 0.25 0.50
MB/HL 2,4	2	59.960/59.973	63.657/63.676	18.360	1.837	0.020/0.067	BS	60012CP	
TW/A	4	65.786/66.040	82.423/82.677		2.362		AL-LF	2777AF	<b>A178/4</b> STD
SE/PB	1	21.994/22.000	25.120/25.146	23.720			BS	60014X	<b>55-4280</b> SEMI









							<b>NA5066</b> 35.00x50.00x10.00mm, ACM			

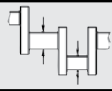
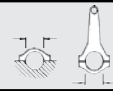

<b>857</b>	<b>78.00</b>	<b>Petrol</b>		
<b>AR 00526 S</b>	4 Cyl.	9:1	1570cc <b>75-76kW (102-103)PS</b>	<b>TD5344</b>





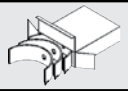

BE/PL	4	49.988/49.998	53.695/53.708	23.440	1.838	0.021/0.069	BS	60010CP	<b>71-4168/4</b> STD 0.25 0.50
MB/HL 1,3,5	3	59.960/59.973	63.657/63.676	25.530	1.837	0.020/0.067	BS	60011CP	<b>H1030/5</b> STD 0.25 0.50
MB/HL 2,4	2	59.960/59.973	63.657/63.676	18.360	1.837	0.020/0.067	BS	60012CP	
TW/A	4	65.786/66.040	82.423/82.677		2.362		AL-LF	2777AF	<b>A178/4</b> STD
SE/PB	1	21.994/22.000	25.120/25.146	23.720			BS	60014X	<b>55-4280</b> SEMI

							<b>NA5066</b> 35.00x50.00x10.00mm, ACM			

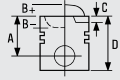
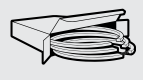

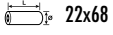

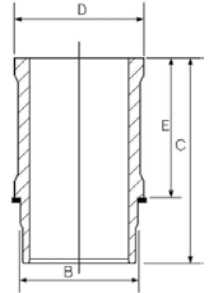

**858**  **78.00** **Petrol**   
**M16A Euro4/Euro5** 4 Cyl. 10.5:1 1586cc **78-88kW (106-120)PS** **TD20932** **111**



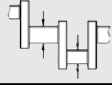
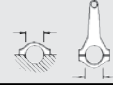

									
BE/PL	8	41.980	45.020	18.000	1.490		AL-LF	64-665-1	<b>01-4947/4</b> STD
MB/HL 1-5	5	51.980	56.020	18.000	2.000		AL-LF	63-665-1	<b>H1331/5</b> STD
MB/HL 1-5	5	51.980	56.020	18.000	2.000		AL-LF	63-665-2	
TW/A	2	59.000	75.000		2.520		AL-LF	65-664-1	<b>A316/2</b> STD

**859**  **78.10** **Petrol**   
**AR 61101** 4 Cyl. 1567cc **76-81kW (103-110)PS** **TD102** **112**

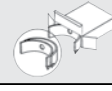
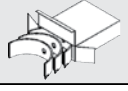











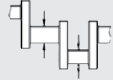

			
<b>87-527300-00</b> STD  A 33.70 B- 16.70 D 82.90  22x68	<b>08-527300-00</b> STD  1.50  CR P 1.75  P 3.50  P	<b>15-632100-00 WH [9]</b> B 84.00 C 150.00 D 94.00 E 95.50 	<b>89-527300-00</b> 87-527300-00 + 15-632100-00





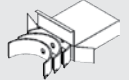

[9] Includes seals [9] Inclut des joints [9] Comprende le guarnizioni [9] Incluye los sellos















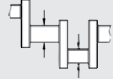

									
BE/PL	4	49.988/49.998	53.695/53.708	23.440	1.838	0.021/0.069	BS	60010CP	<b>71-4168/4</b> STD 0.25 0.50
MB/HL 1,3,5	3	59.960/59.973	63.657/63.676	25.530	1.837	0.020/0.067	BS	60011CP	<b>H1030/5</b> STD 0.25 0.50
MB/HL 2,4	2	59.960/59.973	63.657/63.676	18.360	1.837	0.020/0.067	BS	60012CP	
TW/A	4	65.786/66.040	82.423/82.677		2.362		AL-LF	2777AF	<b>A178/4</b> STD
SE/PB	1	21.994/22.000	25.120/25.146	23.720			BS	60014X	<b>55-4280</b> SEMI



		
	<b>JJ452</b> (MVQ)  <b>JJ452</b>	<b>NA5066</b>  35.00x50.00x10.00mm, ACM

# FIAT GROUP











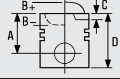
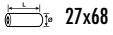
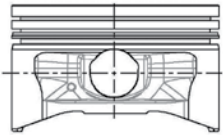
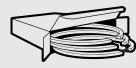

<b>860</b>		 <b>78.10</b>	<b>Petrol</b>							
<b>AR 01563</b>		4 Cyl.	1570cc	<b>79kW (107)PS</b>		<b>TD29</b>		<b>113</b>		
										
BE/PL	4	49.988/49.998	53.695/53.708	23.440	1.838	0.021/0.069	BS	60010CP	<b>71-4168/4</b> STD 0.25 0.50	
MB/HL 1,3,5	3	59.960/59.973	63.657/63.676	25.530	1.837	0.020/0.067	BS	60011CP	<b>H1030/5</b> STD 0.25 0.50	
MB/HL 2,4	2	59.960/59.973	63.657/63.676	18.360	1.837	0.020/0.067	BS	60012CP		
TW/A	4	65.786/66.040	82.423/82.677		2.362		AL-LF	2777AF	<b>A178/4</b> STD	
SE/PB	1	21.994/22.000	25.120/25.146	23.720			BS	60014X	<b>55-4280</b> SEMI	
										
<b>NA5066</b>  35.00x50.00x10.00mm, ACM										



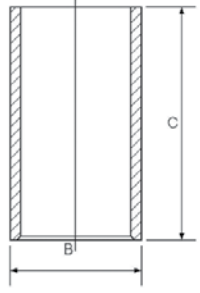

<b>861</b>		 <b>78.10</b>	<b>Petrol</b>							
<b>AR 10538</b>		4 Cyl.	1570cc	<b>83kW (113)PS</b>		<b>TD21726</b>				
										
<b>NA5066</b>  35.00x50.00x10.00mm, ACM										



<b>862</b>		 <b>79.00</b>	<b>Petrol</b>							
<b>192 B3.000</b>		4 Cyl.	10.5:1	1598cc	<b>77kW (105)PS</b>		<b>TD22147</b>		<b>114</b>	
										
BE/PL	4	45.508/45.528	48.629/48.646	19.200	1.547	0.020/0.069	AL-LF	1645RA	<b>01-4127/4</b> STD 0.25 0.50	
BE/PL	4	45.498/45.518	48.630/48.646	19.200	1.544	0.020/0.085	BS	1645CP	<b>71-4126/4</b> STD	
MB/HL 1,2,4,5	4	50.780/50.800	54.507/54.520	20.250	1.849	0.020/0.067	AL-LF	1646RA	<b>H1075/5</b> STD 0.25 0.50	
MB/HL 3	1	50.780/50.800	54.507/54.520	22.750	1.849	0.020/0.067	AL-LF	1647RA		
TW/A	2	56.610/56.864	69.596/69.850		2.362		AL-LF	60987AFA	<b>A198/2</b> STD .005	
SE/PB	1	21.539/21.641	23.939/23.972	25.100			BS	62039Y	<b>55-4288</b> SEMI	
										
<b>NB698</b>  80.00x98.00x10.00mm, FPM										

**863**  **79.375 Diesel** 

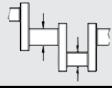
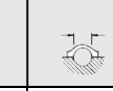
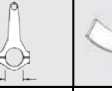
4.108 4 Cyl. 22:1 1760cc **38kW (52)PS** TD141 **115**

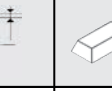
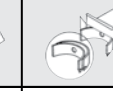
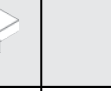
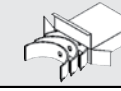
 <p><b>87-315200-00</b> STD</p> <p>A 50.24 D 105.41  27x68</p> 	 <p><b>08-315200-00</b> STD</p> <p>1.99  CR P 1.60  P 1.60  P 3.16  P 4.75  P</p>	 <p><b>14-010900-00 D</b> B 82.63 C 165.10</p> 	
	<p><b>08-313400-00</b> STD</p> <p>1.99  CR P 1.60  P 1.60  P 4.75  P 4.75  P</p>		

										
BE/PL	4	50.787/50.800	54.508/54.521	22.350	1.835	0.038/0.089	AL-LF	2580RA	<b>01-4314/4</b> STD 0.25 0.50	
MB/HL 1-3	3	57.099/57.112	60.833/60.846	31.880	1.836	0.049/0.100	AL-LF	2581RAA	<b>H1138/3</b> STD 0.25	

**864**  **79.50 Diesel** 









198 A2.000 4 Cyl. 16.1:1 1598cc **88kW (120)PS** Turbo Intercooled TD21042 **116**

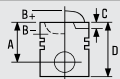
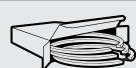





198 A2.000 4 Cyl. 16.1:1 1598cc **88kW (120)PS** Turbo Intercooled TD21047 **116**

198 A2.000 4 Cyl. 16.5:1 1598cc **88kW (120)PS** Turbo Intercooled TD21698 **116**

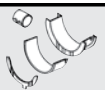
955 A3.000 Euro 5 4 Cyl. 16.5:1 1598cc **88kW (120)PS** Turbo Intercooled TD23575 **116**

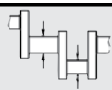
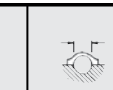
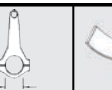
955 A3.000 Euro 5 4 Cyl. 16.5:1 1598cc **88kW (120)PS** Turbo Intercooled TD24591 **116**

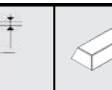
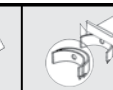

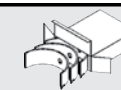

	 <p><b>08-429300-00</b> STD</p> <p>2.00  GDC P 1.75  P 2.00  CR P</p> <p><b>GDC</b>  <b>LKZ-Ring</b> </p>		

										
BE/PL	4	48.226/48.244	51.354/51.366	19.100	1.540	0.030/0.056	EC-LF	71-4776	<b>71-4776/4</b> STD [23]	
MB/HL 1-5	5		56.705/56.718	20.750	1.861		AL-LF	02-4777	<b>H1293/5</b> STD	
TW/A	2	59.000/59.260	73.600/73.850		2.485		AL-LF	04-4778	<b>A291/2</b> STD	
SE/PB	1	26.000	28.939/28.972	22.100			BS-LF	55-4779	<b>55-4779</b> SEMI	

# FIAT GROUP



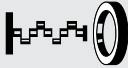







...Continued

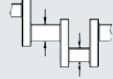



## 864 79.50 Diesel

		
		<b>NA5070</b>  31.00x41.00x7.00mm, FPM <b>NF888</b>  93.00x172.00x12.00mm, FPM

## 865 79.50 Diesel



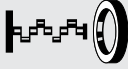

<b>198 A3.000</b>	4 Cyl.	16.5:1	1598cc	<b>77kW (105)PS</b>	<b>Turbo Intercooled</b>	<b>TD24568</b>	<b>116</b>
-------------------	--------	--------	--------	---------------------	--------------------------	----------------	------------

									
MB/HL 1-5	5		56.705/56.718	20.750	1.861		AL-LF	02-4777	<b>H1293/5</b> STD
TW/A	2	59.000/59.260	73.600/73.850		2.485		AL-LF	04-4778	<b>A291/2</b> STD
SE/PB	1	26.000	28.939/28.972	22.100			BS-LF	55-4779	<b>55-4779</b> SEMI

		
		<b>NA5070</b>  31.00x41.00x7.00mm, FPM <b>NF888</b>  93.00x172.00x12.00mm, FPM

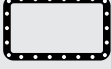







## 866 79.50 Diesel

<b>198 A6.000</b>	4 Cyl.	16.5:1	1598cc	<b>66kW (90)PS</b>	<b>Turbo Intercooled</b>	<b>TD24596</b>	<b>117</b>
<b>263 A3.000</b>	4 Cyl.	16.5:1	1598cc	<b>74kW (101)PS</b>		<b>TD24768</b>	<b>116</b>
<b>263 A4.000</b>	4 Cyl.	16.5:1	1598cc	<b>66kW (90)PS</b>	<b>Turbo Intercooled</b>	<b>TD24769</b>	<b>117</b>
<b>350 A3.000</b>	4 Cyl.	16.5:1	1598cc	<b>85kW (116)PS</b>	<b>Turbo Intercooled</b>	<b>TD24974</b>	<b>117</b>
<b>944 A 3.000</b>	4 Cyl.	16.5:1	1598cc	<b>77kW (105)PS</b>	<b>Turbo Intercooled</b>	<b>TD25422</b>	<b>117</b>

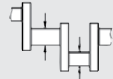
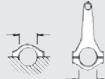
		
		<b>NA5070</b>  31.00x41.00x7.00mm, FPM <b>NF888</b>  93.00x172.00x12.00mm, FPM

## 867 79.50 Diesel





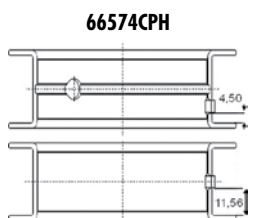
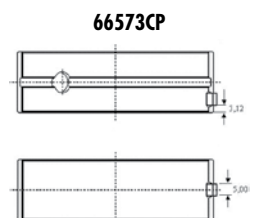





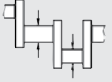

<b>350 A2.000</b>	4 Cyl.	16.5:1	1598cc	<b>85-88kW (116-120)PS</b>	<b>Turbo Intercooled</b>	<b>TD22138</b>	<b>116</b>
<b>350 A2.000</b>	4 Cyl.	16.5:1	1598cc	<b>85-88kW (116-120)PS</b>	<b>Turbo Intercooled</b>	<b>TD24899</b>	<b>117</b>





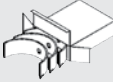

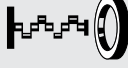

									
BE/PL	4	48.226/48.244	51.354/51.366	19.100	1.540	0.030/0.056	EC-LF	71-4776	<b>71-4776/4</b> STD [23]
MB/HL 1-4	4	76.187/76.200	80.586/80.607	24.990	2.172	0.038/0.097	BS	66573CP	<b>H1094/5</b> STD 0.25
MB/HL 5	1	76.187/76.200	80.586/80.607	31.950	2.172	0.038/0.097	BS	66574CPH	
MB/HL 1-5	5		56.705/56.718	20.750	1.861		AL-LF	02-4777	<b>H1293/5</b> STD

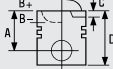
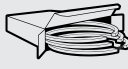











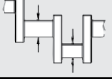



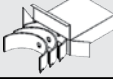

...Continued

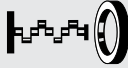







<b>867</b>		 <b>79.50</b>	<b>Diesel</b>							
										
TW/A	2	59.000/59.260	73.600/73.850		2.485		AL-LF	04-4778	<b>A291/2</b> STD	
SE/PB	1	31.990/31.996	34.895/34.920	30.700			BS	66579YA	<b>55-4186</b> SEMI	
SE/PB	1	26.000	28.939/28.972	22.100			BS-LF	55-4779	<b>55-4779</b> SEMI	
										
						<b>NA5070</b>  31.00x41.00x7.00mm, FPM <b>NF888</b>  93.00x172.00x12.00mm, FPM				

<b>868</b>		 <b>79.50</b>	<b>Diesel</b>							
<b>844 A3.000</b>	4 Cyl.	16.1:1	1598cc	<b>88kW (120)PS</b>	<b>Turbo Intercooled</b>	<b>TD25652</b>				
										
				<b>08-429300-00</b>	STD					
				2.00		GDC P				
				1.75		P				
				2.00		CR P				
										

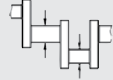
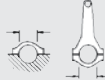
<b>869</b>		 <b>79.50</b>	<b>Diesel</b>							
<b>940 A3.000</b>	4 Cyl.	16.5:1	1598cc	<b>77kW (105)PS</b>	<b>Turbo Intercooled</b>	<b>TD23923</b>	<b>116</b>			
<b>955 A4.000</b>	4 Cyl.		1598cc	<b>85kW (115)PS</b>	<b>Turbocharged</b>	<b>TD23451</b>	<b>116</b>			
<b>955 A4.000</b>	4 Cyl.		1598cc	<b>85kW (115)PS</b>	<b>Turbocharged</b>	<b>TD25735</b>	<b>117</b>			
<b>955 A4.000</b>	4 Cyl.	16.5:1	1598cc	<b>85kW (116)PS</b>	<b>Turbo Intercooled</b>	<b>TD24651</b>	<b>117</b>			
										
BE/PL	4	48.226/48.244	51.354/51.366	19.100	1.540	0.030/0.056	EC-LF	71-4776	<b>71-4776/4</b> STD [23]	
MB/HL 1-5	5		56.705/56.718	20.750	1.861		AL-LF	02-4777	<b>H1293/5</b> STD	
TW/A	2	59.000/59.260	73.600/73.850		2.485		AL-LF	04-4778	<b>A291/2</b> STD	
SE/PB	1	26.000	28.939/28.972	22.100			BS-LF	55-4779	<b>55-4779</b> SEMI	
										
						<b>NA5070</b>  31.00x41.00x7.00mm, FPM <b>NF888</b>  93.00x172.00x12.00mm, FPM				

# FIAT GROUP

<b>870</b>	 <b>80.00</b>	<b>Petrol</b>			
124 BL 1.016	4 Cyl.	7.5:1	1438cc	<b>34kW (46)PS</b>	<b>TD6890</b>
128 A 064	4 Cyl.	9.2:1	1116cc	<b>40-44kW (54-60)PS</b>	<b>TD23118</b>
128 BB.0A0	4 Cyl.	8.8:1	1116cc	<b>48kW (65)PS</b>	<b>TD23459</b>
138 AE 0A.0	4 Cyl.	9.2:1	1116cc	<b>44kW (60)PS</b>	<b>TD23461</b>
146 A4.000	4 Cyl.	9.2:1	1116cc	<b>43kW (58)PS</b>	<b>TD22226</b>



									
BE/PL	4	45.508/45.528	48.629/48.646	19.200	1.547	0.020/0.069	AL-LF	1645RA	<b>01-4127/4</b> STD 0.25 0.50
BE/PL	4	45.508/45.528	48.629/48.646	19.200	1.538	0.025/0.087	AL-LF	60985RA	<b>01-4171/4</b> STD



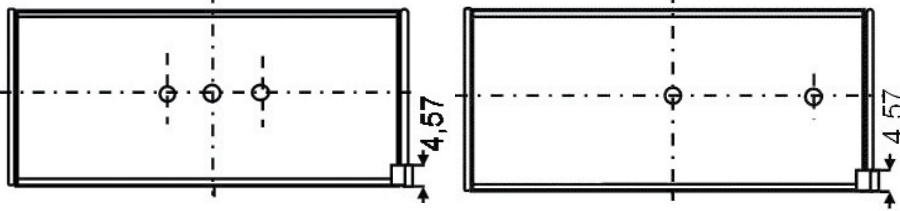



1645RA

60985RA

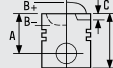
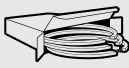





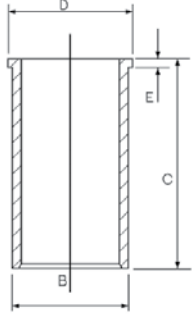

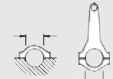

MB/HL 1,2,4,5	4	50.785/50.805	54.507/54.520	20.250	1.831	0.040/0.098	AL-LF	60986RA	<b>H1028/5</b> STD 0.25
MB/HL 3	1	50.785/50.805	54.507/54.520	22.750	1.831	0.040/0.098	AL-LF	60987RA	
TW/A	2	56.610/56.864	69.596/69.850		2.362		AL-LF	60987AFA	<b>A198/2</b> STD .005
SE/PB	1	21.539/21.641	23.939/23.972	25.100			BS	62039Y	<b>55-4288</b> SEMI

<b>871</b>	 <b>80.00</b>	<b>Petrol</b>			
128 A.000	4 Cyl.	8.8:1	1116cc	<b>33-48kW (45-65)PS</b>	<b>TD888 118</b>
128 A.048	4 Cyl.	9.2:1	1116cc	<b>33kW (45)PS</b>	<b>TD5378 119</b>
138 B.000	4 Cyl.	9.2:1	1116cc	<b>40-44kW (55-60)PS</b>	<b>TD923 121</b>

			
<b>87-203100-00</b> STD <b>87-203106-00</b> 0.40mm <b>87-203108-00</b> 0.60mm  <b>A</b> 35.05 <b>B+</b> 0.60 <b>D</b> 77.05  22x71	<b>08-203100-00</b> STD <b>08-203104-00</b> 0.20mm <b>08-203106-00</b> 0.40mm <b>08-203108-00</b> 0.60mm <b>08-203110-00</b> 0.80mm <b>08-203111-00</b> 1.00mm  1.50  CR P 2.00  P 3.95  P	<b>14-018920-00 D</b> <b>B</b> 84.00 <b>C</b> 114.00  	

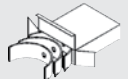
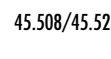
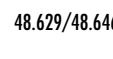
...Continued

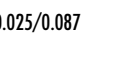







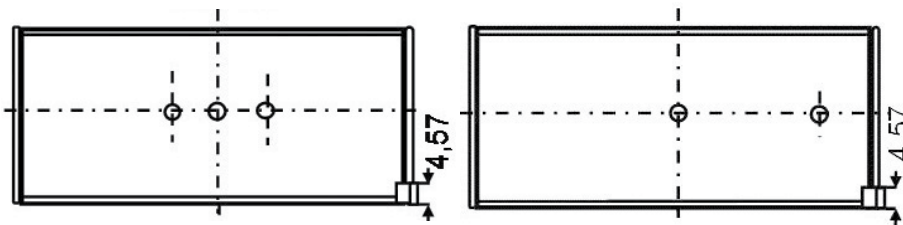



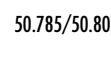
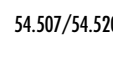







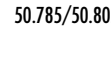
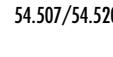

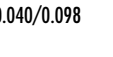

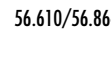
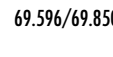

**871**  **80.00** **Petrol**

									
BE/PL	4	45.508/45.528	48.629/48.646	19.200	1.547	0.020/0.069	AL-LF	1645RA	01-4127/4 STD 0.25 0.50
									
BE/PL	4	45.508/45.528	48.629/48.646	19.200	1.538	0.025/0.087	AL-LF	60985RA	01-4171/4 STD

1645RA

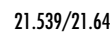
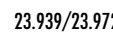

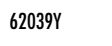
60985RA

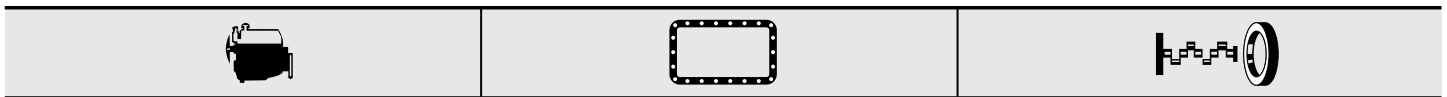

									
MB/HL 1,2,4,5	4	50.785/50.805	54.507/54.520	20.250	1.831	0.040/0.098	AL-LF	60986RA	H1028/5 STD 0.25
									
MB/HL 3	1	50.785/50.805	54.507/54.520	22.750	1.831	0.040/0.098	AL-LF	60987RA	
									
TW/A	2	56.610/56.864	69.596/69.850	2.362			AL-LF	60987AFA	A198/2 STD .005
									
SE/PB	1	21.539/21.641	23.939/23.972	25.100			BS	62039Y	55-4288 SEMI





JH494







NB818  40.00x56.00x7.00mm, ACM  
NA5049  64.00x80.00x8.00mm, ACM

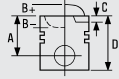
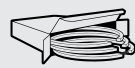

JH494

**872**  **80.00** **Petrol** 



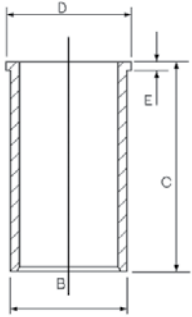





128 AC5.000      4 Cyl.      9.2:1      1116cc      48kW (65)PS      TD891      120

			
	<p>08-203100-00 STD</p> <p>08-203104-00 0.20mm</p> <p>08-203106-00 0.40mm</p> <p>08-203108-00 0.60mm</p> <p>08-203110-00 0.80mm</p> <p>08-203111-00 1.00mm</p> <p>1.50  CR P</p> <p>2.00  P</p> <p>3.95  P</p>	<p>14-028710-00 D</p> <p>B 86.53    C 125.10    D 95.00    E 7.80</p> 	

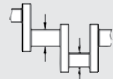
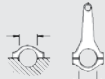
# FIAT GROUP

...Continued

## 872

									
BE/PL	4	45.508/45.528	48.629/48.646	19.200	1.547	0.020/0.069	AL-LF	1645RA	<b>01-4127/4</b> STD 0.25 0.50
BE/PL	4	45.508/45.528	48.629/48.646	19.200	1.538	0.025/0.087	AL-LF	60985RA	<b>01-4171/4</b> STD

1645RA



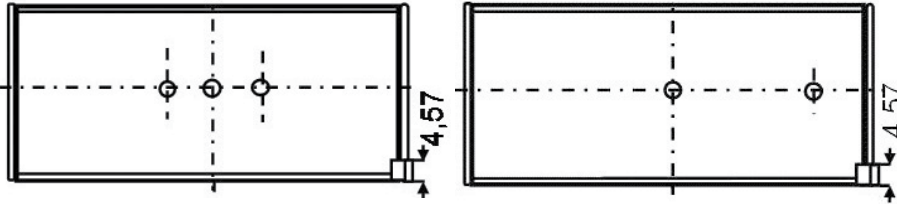





60985RA

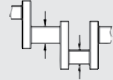
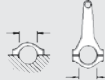

MB/HL 1,2,4,5	4	50.785/50.805	54.507/54.520	20.250	1.831	0.040/0.098	AL-LF	60986RA	<b>H1028/5</b> STD 0.25
MB/HL 3	1	50.785/50.805	54.507/54.520	22.750	1.831	0.040/0.098	AL-LF	60987RA	
TW/A	2	56.610/56.864	69.596/69.850		2.362		AL-LF	60987AFA	<b>A198/2</b> STD .005
SE/PB	1	21.539/21.641	23.939/23.972	25.100			BS	62039Y	<b>55-4288</b> SEMI

## 873

<b>138 B1.000</b>	4 Cyl.	9.6:1	1116cc	<b>40kW (55)PS</b>	<b>TD924</b>	<b>122</b>
<b>138 C1.000</b>	4 Cyl.	9.2:1	1116cc	<b>40-42kW (55-57)PS</b>	<b>TD18371</b>	<b>123</b>
<b>146 A4.044</b>	4 Cyl.	9.2:1	1116cc	<b>37kW (50)PS</b>	<b>TD9469</b>	<b>124</b>
<b>146 A4.048</b>	4 Cyl.	9.2:1	1116cc	<b>43kW (58)PS</b>	<b>TD4375</b>	<b>125</b>

									
BE/PL	4	45.508/45.528	48.629/48.646	19.200	1.547	0.020/0.069	AL-LF	1645RA	<b>01-4127/4</b> STD 0.25 0.50
BE/PL	4	45.508/45.528	48.629/48.646	19.200	1.538	0.025/0.087	AL-LF	60985RA	<b>01-4171/4</b> STD

1645RA

60985RA

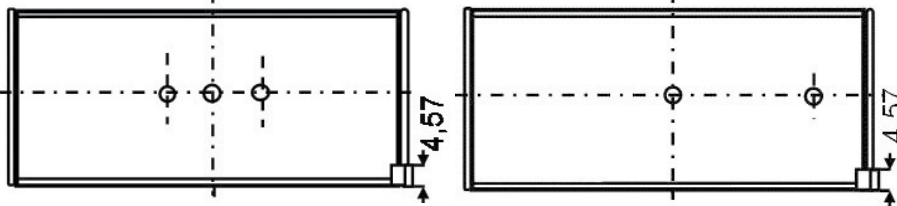

MB/HL 1,2,4,5	4	50.785/50.805	54.507/54.520	20.250	1.831	0.040/0.098	AL-LF	60986RA	<b>H1028/5</b> STD 0.25
MB/HL 3	1	50.785/50.805	54.507/54.520	22.750	1.831	0.040/0.098	AL-LF	60987RA	
TW/A	2	56.610/56.864	69.596/69.850		2.362		AL-LF	60987AFA	<b>A198/2</b> STD .005
SE/PB	1	21.539/21.641	23.939/23.972	25.100			BS	62039Y	<b>55-4288</b> SEMI

...Continued

<b>873</b>		<b>80.00</b>	<b>Petrol</b>								
				<b>JH494</b>						<b>NB818</b> 40.00x56.00x7.00mm, ACM <b>NA5049</b> 64.00x80.00x8.00mm, ACM	
				<b>JH494</b>							

<b>874</b>		<b>80.00</b>	<b>Petrol</b>							
<b>146 A6.000</b>		4 Cyl.	9.35:1	1116cc	<b>43kW (58)PS</b>			<b>TD9493</b>	<b>126</b>	

BE/PL	4	43.988/44.008	47.130/47.142	18.500	1.546	0.030/0.087	AL-LF	68090RA	<b>01-4207/4</b> STD 0.25 0.50
MB/HL 1,2,4,5	4	48.189/48.209	51.921/51.934	17.650	1.841	0.030/0.088	AL-LF	68091RA	<b>H1069/5</b> STD 0.25 0.50
MB/HL 3	1	48.189/48.209	51.921/51.934	25.250	1.841	0.030/0.088	AL-LF	68092RA	
TW/A	2	54.224/54.478	66.996/67.520		2.362		AL-LF	68092AF	<b>A221/2</b> STD
SE/PB	1	21.539/21.641	23.939/23.972	25.100			BS	62039Y	<b>55-4288</b> SEMI





				<b>JH494</b>						<b>NB818</b> 40.00x56.00x7.00mm, ACM <b>NA5049</b> 64.00x80.00x8.00mm, ACM	
				<b>JH494</b>							



<b>875</b>		<b>80.00</b>	<b>Petrol</b>							
<b>146 A9.000</b>		4 Cyl.		1116cc	<b>40kW (55)PS</b>			<b>TD945</b>	<b>127</b>	



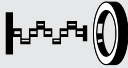
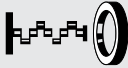





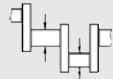

BE/PL	4	43.988/44.008	47.130/47.142	18.500	1.546	0.030/0.087	AL-LF	68090RA	<b>01-4207/4</b> STD 0.25 0.50
MB/HL 1,2,4,5	4	48.189/48.209	51.921/51.934	17.650	1.841	0.030/0.088	AL-LF	68091RA	<b>H1069/5</b> STD 0.25 0.50
MB/HL 3	1	48.189/48.209	51.921/51.934	25.250	1.841	0.030/0.088	AL-LF	68092RA	
TW/A	2	54.224/54.478	66.996/67.520		2.362		AL-LF	68092AF	<b>A221/2</b> STD
SE/PB	1	21.539/21.641	23.939/23.972	25.100			BS	62039Y	<b>55-4288</b> SEMI

# FIAT GROUP

...Continued

<b>875</b>	 <b>80.00</b>	<b>Petrol</b>
		
	<b>JJ078</b>	<b>NB818</b>  40.00x56.00x7.00mm, ACM
		
	<b>JJ078</b>	

<b>876</b>	 <b>80.00</b>	<b>Petrol</b>				
<b>146 C3.000</b>	4 Cyl.	9.2:1	1116cc	<b>36kW (49)PS</b>	<b>TD4348</b>	<b>128</b>



									
BE/PL	4	45.508/45.528	48.629/48.646	19.200	1.547	0.020/0.069	AL-LF	1645RA	<b>01-4127/4</b> STD .025 0.50
BE/PL	4	45.508/45.528	48.629/48.646	19.200	1.538	0.025/0.087	AL-LF	60985RA	<b>01-4171/4</b> STD

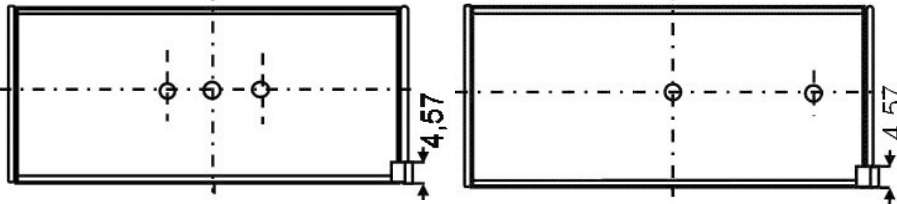

1645RA





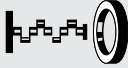
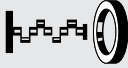
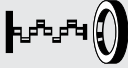





60985RA

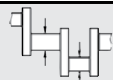









MB/HL 1,2,4,5	4	50.785/50.805	54.507/54.520	20.250	1.831	0.040/0.098	AL-LF	60986RA	<b>H1028/5</b> STD 0.25
MB/HL 3	1	50.785/50.805	54.507/54.520	22.750	1.831	0.040/0.098	AL-LF	60987RA	
TW/A	2	56.610/56.864	69.596/69.850		2.362		AL-LF	60987AFA	<b>A198/2</b> STD .005
SE/PB	1	21.539/21.641	23.939/23.972	25.100			BS	62039Y	<b>55-4288</b> SEMI

		
	<b>HR397</b>	<b>NB815</b>  23.00x35.00x7.00mm, FPM <b>NA5061</b>  74.00x88.00x8.00mm, FPM

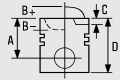







<b>877</b>	 <b>80.00</b>	<b>Petrol</b>				
<b>831 B8.000</b>	4 Cyl.		1116cc	<b>47kW (64)PS</b>	<b>TD1819</b>	<b>129</b>

									
BE/PL	4	45.508/45.528	48.629/48.646	19.200	1.547	0.020/0.069	AL-LF	1645RA	<b>01-4127/4</b> STD 0.25 0.50
MB/HL 1,2,4,5	4	50.785/50.805	54.507/54.520	20.250	1.831	0.040/0.098	AL-LF	60986RA	<b>H1028/5</b> STD 0.25
MB/HL 3	1	50.785/50.805	54.507/54.520	22.750	1.831	0.040/0.098	AL-LF	60987RA	
TW/A	2	56.610/56.864	69.596/69.850		2.362		AL-LF	60987AFA	<b>A198/2</b> STD .005
SE/PB	1	21.539/21.641	23.939/23.972	25.100			BS	62039Y	<b>55-4288</b> SEMI

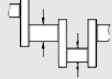
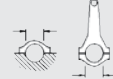
<b>878</b>	 <b>80.00</b>	<b>Petrol</b>			
<b>AR 30102</b>	4 Cyl.	1186cc	<b>46kW (63)PS</b>	<b>TD5335</b>	<b>130</b>
<b>AR 30160</b>	4 Cyl.	9:1 1351cc	<b>51kW (69)PS</b>	<b>TD81</b>	<b>131</b>
<b>AR 30587</b>	4 Cyl.	1351cc	<b>63-66kW (86-90)PS</b>	<b>TD97</b>	<b>138</b>
<b>AR 31000</b>	4 Cyl.	9:1 1186cc	<b>44-47kW (60-64)PS</b>	<b>TD99</b>	<b>133</b>
<b>AR 31010</b>	4 Cyl.	9:1 1351cc	<b>63kW (86)PS</b>	<b>TD100</b>	<b>141</b>

			
	<b>08-107800-10</b> STD		
	1.50  CR P		
	1.75  P		
	4.00  CR [15]		

[15] Steel      [15] Acier      [15] Acciaio      [15] Acero

									
BE/PL	4	49.984/50.000	53.696/53.708	17.800	1.836	0.024/0.077	AL-LF	66325RA	<b>01-4178/4</b> STD 0.25 0.50
BE/PL	4	49.992/50.000	53.696/53.708	17.800	1.836	0.024/0.069	AL-LF	66625RA	<b>01-4188/4</b> STD 0.25 0.50

**66325RA**

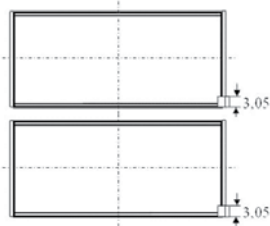

**66625RA**

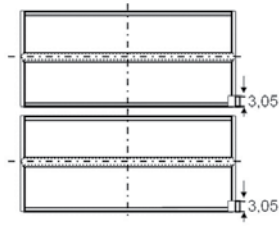



MB/HL 1-3	3	59.944/59.957	63.663/63.673	23.400	1.841	0.024/0.072	AL-LF	66326RA	<b>H1044/3</b> STD 0.25 0.50
TW/A	2	65.790/66.040	82.420/82.680		2.362		BS	66326AF	<b>A205/2</b> STD
SE/PB	1	20.996/21.000	23.005/23.020	23.500			BS	66329Y	<b>55-4505</b> SEMI

		
---	---	---



**JH565**











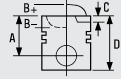
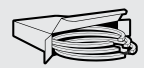





**JH565**

**NA5063**  40.00x56.00x10.00mm, ACM  
**NA5065**  62.00x80.00x12.00mm, ACM

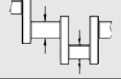
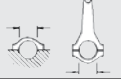
# FIAT GROUP



<b>879</b>	 <b>80.00</b>	<b>Petrol</b>							
<b>AR 30102 S</b>	4 Cyl.		1186cc	<b>44kW (60)PS</b>				<b>TD5336</b>	<b>130</b>
<b>AR 30180</b>	4 Cyl.		1286cc	<b>48-50kW (65-68)PS</b>				<b>TD84</b>	<b>134</b>
<b>AR 30732</b>	4 Cyl.	9.7:1	1351cc	<b>66kW (90)PS</b>				<b>TD107</b>	

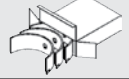

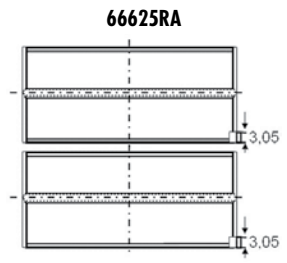
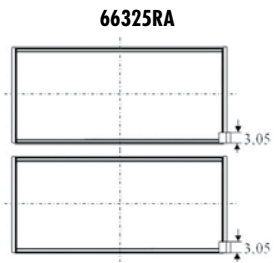



			
	<b>08-107800-10</b> STD		
	1.50  CR P		
	1.75  P		
	4.00  CR [15]		
[15] Steel	[15] Acier	[15] Acciaio	[15] Acero



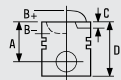
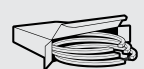





									
BE/PL	4	49.984/50.000	53.696/53.708	17.800	1.836	0.024/0.077	AL-LF	66325RA	<b>01-4178/4</b> STD 0.25 0.50
BE/PL	4	49.992/50.000	53.696/53.708	17.800	1.836	0.024/0.069	AL-LF	66625RA	<b>01-4188/4</b> STD 0.25 0.50

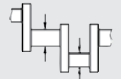
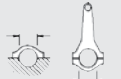

MB/HL 1-3	3	59.944/59.957	63.663/63.673	23.400	1.841	0.024/0.072	AL-LF	66326RA	<b>H1044/3</b> STD 0.25 0.50
TW/A	2	65.790/66.040	82.420/82.680		2.362		BS	66326AF	<b>A205/2</b> STD
SE/PB	1	20.996/21.000	23.005/23.020	23.500			BS	66329Y	<b>55-4505</b> SEMI

<b>880</b>	 <b>80.00</b>	<b>Petrol</b>							
<b>AR 30104</b>	4 Cyl.	9:1	1186cc	<b>50kW (68)PS</b>				<b>TD77</b>	<b>131</b>
<b>AR 30164</b>	4 Cyl.	9:1	1351cc	<b>55kW (75)PS</b>				<b>TD82</b>	<b>136</b>
<b>AR 30168</b>	4 Cyl.	9.5:1	1351cc	<b>63-66kW (85-90)PS</b>				<b>TD83</b>	<b>137</b>
<b>AR 30502</b>	4 Cyl.	9:1	1351cc	<b>55-58kW (75-79)PS</b>				<b>TD88</b>	<b>138</b>
<b>AR 30586</b>	4 Cyl.		1351cc	<b>55kW (75)PS</b>				<b>TD96</b>	<b>138</b>



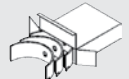





			
	<b>08-107800-10</b> STD		
	1.50  CR P		
	1.75  P		
	4.00  CR [15]		
[15] Steel	[15] Acier	[15] Acciaio	[15] Acero



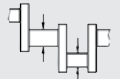
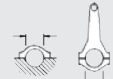

									
BE/PL	4	49.984/50.000	53.696/53.708	17.800	1.836	0.024/0.077	AL-LF	66325RA	<b>01-4178/4</b> STD 0.25 0.50
MB/HL 1-3	3	59.944/59.957	63.663/63.673	23.400	1.841	0.024/0.072	AL-LF	66326RA	<b>H1044/3</b> STD 0.25 0.50



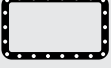

...Continued







**880**  **80.00** **Petrol**

									
TW/A	2	65.790/66.040	82.420/82.680		2.362		BS	66326AF	A205/2 STD
SE/PB	1	20.996/21.000	23.005/23.020	23.500			BS	66329Y	55-4505 SEMI

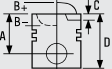
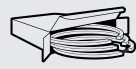







		
	JH565  JH565	NA5063  40.00x56.00x10.00mm, ACM NA5065  62.00x80.00x12.00mm, ACM

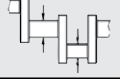
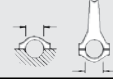

**881**  **80.00** **Petrol** 

AR 30500      4 Cyl.      1186cc      44-50kW (60-68)PS      TD87      130









			
	08-107800-10    STD 1.50  CR P 1.75  P 4.00  CR [15]		

[15] Steel      [15] Acier      [15] Acciaio      [15] Acero

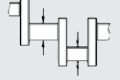
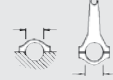
									
BE/PL	4	49.984/50.000	53.696/53.708	17.800	1.836	0.024/0.077	AL-LF	66325RA	01-4178/4 STD 0.25 0.50
MB/HL 1-3	3	59.944/59.957	63.663/63.673	23.400	1.841	0.024/0.072	AL-LF	66326RA	H1044/3 STD 0.25 0.50
TW/A	2	65.790/66.040	82.420/82.680		2.362		BS	66326AF	A205/2 STD
SE/PB	1	20.996/21.000	23.005/23.020	23.500			BS	66329Y	55-4505 SEMI

**882**  **80.00** **Petrol** 





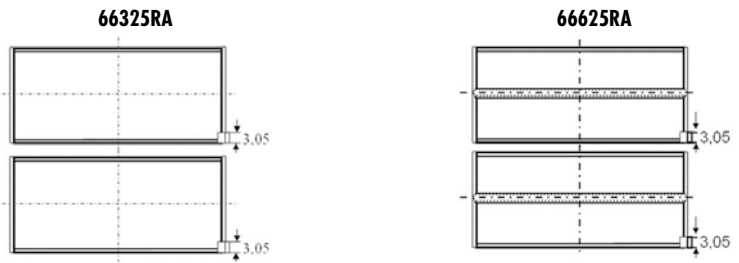



AR 30585      4 Cyl.      1186cc      50kW (68)PS      TD10129      132

									
BE/PL	4	49.984/50.000	53.696/53.708	17.800	1.836	0.024/0.077	AL-LF	66325RA	01-4178/4 STD 0.25 0.50
BE/PL	4	49.992/50.000	53.696/53.708	17.800	1.836	0.024/0.069	AL-LF	66625RA	01-4188/4 STD 0.25 0.50

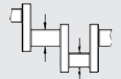
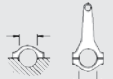









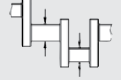

# FIAT GROUP

...Continued

<b>882</b>		 <b>80.00</b>	<b>Petrol</b>						
									

		
	<b>JH565</b>	<b>NA5063</b>  40.00x56.00x10.00mm, ACM <b>NA5065</b>  62.00x80.00x12.00mm, ACM
		
	<b>JH565</b>	





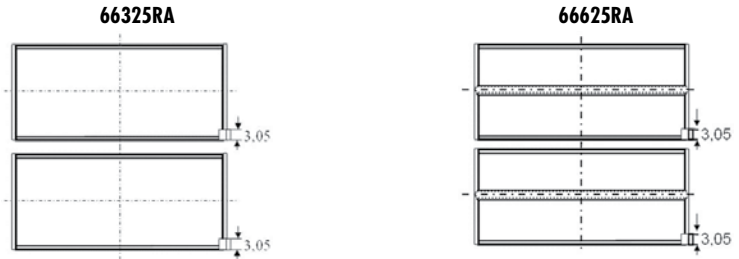



<b>883</b>		 <b>80.00</b>	<b>Petrol</b>						
<b>AR 30743</b>	4 Cyl.	1186cc	<b>57kW (80)PS</b>				<b>TD113</b>		

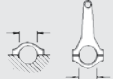

									
BE/PL	4	49.984/50.000	53.696/53.708	17.800	1.836	0.024/0.077	AL-LF	66325RA	<b>01-4178/4</b> STD 0.25 0.50
BE/PL	4	49.992/50.000	53.696/53.708	17.800	1.836	0.024/0.069	AL-LF	66625RA	<b>01-4188/4</b> STD 0.25 0.50









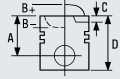
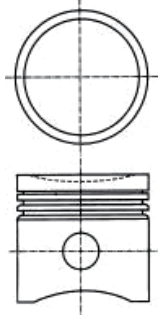

MB/HL 1-3	3	59.944/59.957	63.663/63.673	23.400	1.841	0.024/0.072	AL-LF	66326RA	<b>H1044/3</b> STD 0.25 0.50
TW/A	2	65.790/66.040	82.420/82.680		2.362		BS	66326AF	<b>A205/2</b> STD
SE/PB	1	20.996/21.000	23.005/23.020	23.500			BS	66329Y	<b>55-4505</b> SEMI









<b>884</b>		 <b>80.00</b>	<b>Petrol</b>						
<b>AR 30100</b>	4 Cyl.	1351cc	<b>58kW (79)PS</b>				<b>TD76</b>	<b>135</b>	

									
BE/PL	4	49.984/50.000	53.696/53.708	17.800	1.836	0.024/0.077	AL-LF	66325RA	<b>01-4178/4</b> STD 0.25 0.50
MB/HL 1-3	3	59.944/59.957	63.663/63.673	23.400	1.841	0.024/0.072	AL-LF	66326RA	<b>H1044/3</b> STD 0.25 0.50
TW/A	2	65.790/66.040	82.420/82.680		2.362		BS	66326AF	<b>A205/2</b> STD
SE/PB	1	20.996/21.000	23.005/23.020	23.500			BS	66329Y	<b>55-4505</b> SEMI

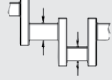
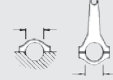
<b>885</b>	 <b>80.00</b>	<b>Petrol</b>				
<b>AR 30753</b>	4 Cyl.	9.5:1	135lcc	<b>65-66kW (88-90)PS</b>	<b>TD119</b>	<b>139</b>
<b>AR 30755</b>	4 Cyl.	9.5:1	135lcc	<b>65-66kW (88-90)PS</b>	<b>TD120</b>	<b>140</b>
<b>AR 33501</b>	4 Cyl.		135lcc	<b>66kW (90)PS</b>	<b>TD123</b>	<b>140</b>





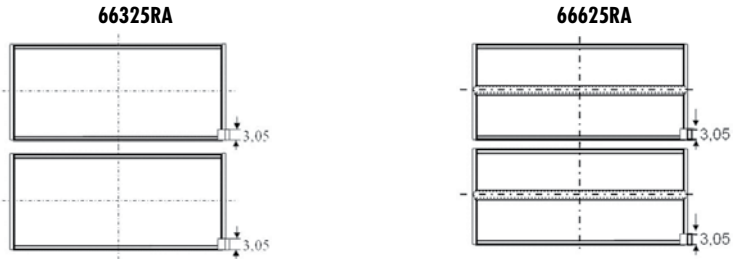

				
<b>87-107806-10</b> 0.40mm A 37.40 B- 3.90 D 70.40  21x62		<b>08-107800-10</b> STD 1.50  CR P 1.75  P 4.00  CR [15]		

[15] Steel      [15] Acier      [15] Acciaio      [15] Acero

									
BE/PL	4	49.984/50.000	53.696/53.708	17.800	1.836	0.024/0.077	AL-LF	66325RA	<b>01-4178/4</b> STD 0.25 0.50
BE/PL	4	49.992/50.000	53.696/53.708	17.800	1.836	0.024/0.069	AL-LF	66625RA	<b>01-4188/4</b> STD 0.25 0.50



MB/HL 1-3	3	59.944/59.957	63.663/63.673	23.400	1.841	0.024/0.072	AL-LF	66326RA	<b>H1044/3</b> STD 0.25 0.50
TW/A	2	65.790/66.040	82.420/82.680		2.362		BS	66326AF	<b>A205/2</b> STD
SE/PB	1	20.996/21.000	23.005/23.020	23.500			BS	66329Y	<b>55-4505</b> SEMI

		
	<b>JH565</b>  <b>JH565</b>	<b>NA5063</b>  40.00x56.00x10.00mm, ACM <b>NA5065</b>  62.00x80.00x12.00mm, ACM

# FIAT GROUP

<b>886</b>	<b>80.00</b>	<b>Petrol</b>	
<b>AR 01644</b>	4 Cyl.	1357cc	<b>66-70kW (90-95)PS</b>
<b>AR 11644</b>	4 Cyl.	9:1	<b>66-70kW (90-95)PS</b>
			<b>TD35 142</b>
			<b>TD22399</b>

BE/PL	4	44.963/44.975	48.658/48.671	23.440	1.829	0.025/0.075	AL-LF	2650RA	<b>01-4307/4</b> 0.25
MB/HL 1,3,5	3	59.960/59.973	63.657/63.676	25.530	1.837	0.020/0.067	BS	60011CP	<b>H1030/5</b> STD 0.25 0.50
MB/HL 2,4	2	59.960/59.973	63.657/63.676	18.360	1.837	0.020/0.067	BS	60012CP	
TW/A	4	65.786/66.040	82.423/82.677		2.362		AL-LF	2777AF	<b>A178/4</b> STD
SE/PB	1	21.994/22.000	25.120/25.146	23.720			BS	60014X	<b>55-4280</b> SEMI

		<b>NA5066</b> 35.00x50.00x10.00mm, ACM

<b>887</b>	<b>80.00</b>	<b>Petrol</b>	
<b>124 AC.000</b>	4 Cyl.	8.9:1	<b>59-66kW (80-90)PS</b>
			<b>TD13413 143</b>

	<b>08-203100-00</b> STD <b>08-203104-00</b> 0.20mm <b>08-203106-00</b> 0.40mm <b>08-203108-00</b> 0.60mm <b>08-203110-00</b> 0.80mm <b>08-203111-00</b> 1.00mm  1.50  CR P 2.00  P 3.95  P	<b>14-018920-00 D</b> <b>B 84.00 C 114.00</b>  	



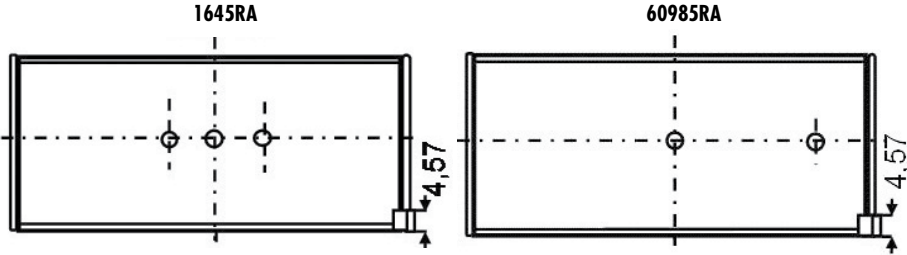





BE/PL	4	45.508/45.528	48.629/48.646	19.200	1.547	0.020/0.069	AL-LF	1645RA	<b>01-4127/4</b> STD 0.25 0.50
BE/PL	4	45.508/45.528	48.629/48.646	19.200	1.538	0.025/0.087	AL-LF	60985RA	<b>01-4171/4</b> STD

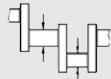
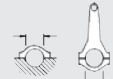

MB/HL 1,2,4,5	4	50.785/50.805	54.507/54.520	20.250	1.831	0.040/0.098	AL-LF	60986RA	<b>H1028/5</b> STD 0.25
MB/HL 3	1	50.785/50.805	54.507/54.520	22.750	1.831	0.040/0.098	AL-LF	60987RA	
TW/A	2	56.610/56.864	69.596/69.850		2.362		AL-LF	60987AFA	<b>A198/2</b> STD .005





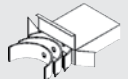

...Continued



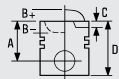
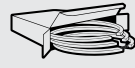



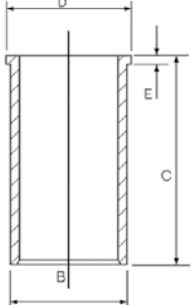

**887**  **80.00** **Petrol**

										
SE/PB	1	21.539/21.641	23.939/23.972	25.100				BS	62039Y	55-4288 SEMI

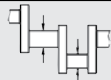
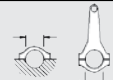
**888**  **80.00** **Petrol**



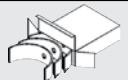

124 B2.000      4 Cyl.      9:1      1438cc      51-55kW (70-75)PS      TD13412      144

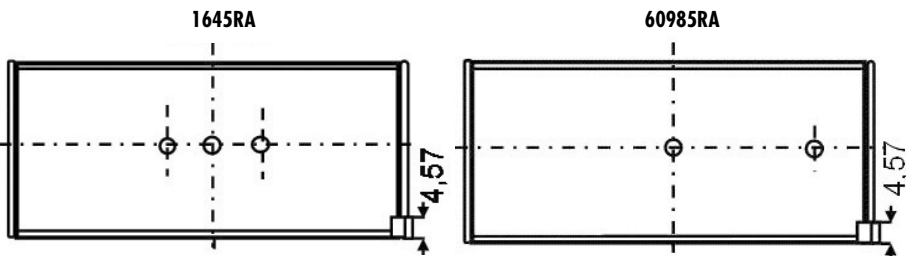
			
	<p><b>08-203100-00</b> STD</p> <p><b>08-203104-00</b> 0.20mm</p> <p><b>08-203106-00</b> 0.40mm</p> <p><b>08-203108-00</b> 0.60mm</p> <p><b>08-203110-00</b> 0.80mm</p> <p><b>08-203111-00</b> 1.00mm</p> <p>1.50  CR P</p> <p>2.00  P</p> <p>3.95  P</p>	<p><b>14-018920-00 D</b></p> <p>B 84.00 C 114.00</p> 	

										
BE/PL	4	45.508/45.528	48.629/48.646	19.200	1.547	0.020/0.069	AL-LF	1645RA		01-4127/4 STD 0.25 0.50
BE/PL	4	45.508/45.528	48.629/48.646	19.200	1.538	0.025/0.087	AL-LF	60985RA		01-4171/4 STD



MB/HL 1,2,4,5	4	50.785/50.805	54.507/54.520	20.250	1.831	0.040/0.098	AL-LF	60986RA	H1028/5 STD 0.25
MB/HL 3	1	50.785/50.805	54.507/54.520	22.750	1.831	0.040/0.098	AL-LF	60987RA	
TW/A	2	56.610/56.864	69.596/69.850		2.362		AL-LF	60987AFA	A198/2 STD .005
SE/PB	1	21.539/21.641	23.939/23.972	25.100			BS	62039Y	55-4288 SEMI

		
		<p><b>NB818</b>  40.00x56.00x7.00mm, ACM</p> <p><b>NA5050</b>  70.00x90.00x10.00mm, ACM</p>

# FIAT GROUP

## 889



80.00

Petrol



828 A2.000

4 Cyl.

1438cc

66kW (90)PS

TD1793

145

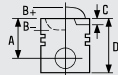

08-203100-00 STD  
 08-203104-00 0.20mm  
 08-203106-00 0.40mm  
 08-203108-00 0.60mm  
 08-203110-00 0.80mm  
 08-203111-00 1.00mm

1.50 CR P  
 2.00 P  
 3.95 P

BE/PL	4	45.508/45.528	48.629/48.646	19.200	1.547	0.020/0.069	AL-LF	1645RA	01-4127/4 STD 0.25 0.50
BE/PL	4	45.508/45.528	48.629/48.646	19.200	1.538	0.025/0.087	AL-LF	60985RA	01-4171/4 STD

1645RA

60985RA

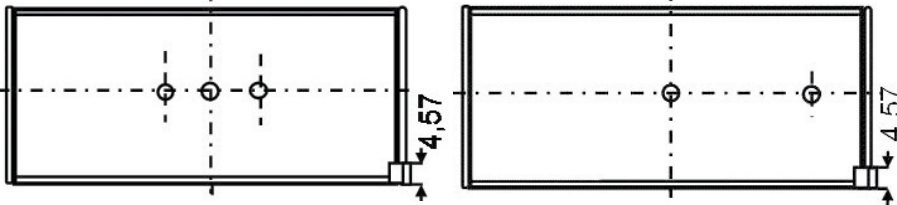

MB/HL 1,2,4,5	4	50.785/50.805	54.507/54.520	20.250	1.831	0.040/0.098	AL-LF	60986RA	H1028/5 STD 0.25
MB/HL 3	1	50.785/50.805	54.507/54.520	22.750	1.831	0.040/0.098	AL-LF	60987RA	
TW/A	2	56.610/56.864	69.596/69.850		2.362		AL-LF	60987AFA	A198/2 STD .005
SE/PB	1	21.539/21.641	23.939/23.972	25.100			BS	62039Y	55-4288 SEMI

## 890



80.00

Petrol



131 AZ.000

4 Cyl.

9.2:1

1440cc

34-38kW (46-52)PS

TD6893

131 BZ 0C0

4 Cyl.

1440cc

38kW (52)PS

TD6891

131 FZ



4 Cyl.







1440cc



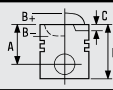
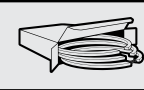





38kW (52)PS

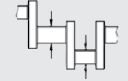
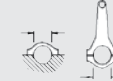

TD6892









BE/PL	4	48.224/48.244	51.330/51.346	19.500	1.540	0.020/0.067	AL-LF	66315RA	01-4176/4 STD 0.25 0.50
MB/HL 1,2,4,5	4	52.985/53.005	56.717/56.730	20.750	1.841	0.030/0.088	AL-LF	66316RA	H1043/5 STD 0.25 0.50 0.75
MB/HL 3	1	52.985/53.005	56.717/56.730	24.250	1.841	0.030/0.088	AL-LF	66317RA	
TW/A	2	59.000/59.250	73.600/73.850		2.362		BS	62037AF	A201/2 STD .005
SE/PB	1	21.539/21.641	23.939/23.972	25.100			BS	62039Y	55-4288 SEMI

**891**  **80.00** **Petrol**   
**132 A.000** 4 Cyl. 9:1 1592cc **72kW (98)PS** **TD19053** **146**

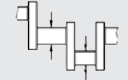

			
	<b>08-203100-00</b> STD <b>08-203104-00</b> 0.20mm <b>08-203106-00</b> 0.40mm <b>08-203108-00</b> 0.60mm <b>08-203110-00</b> 0.80mm <b>08-203111-00</b> 1.00mm  1.50  CR P 2.00  P 3.95  P		



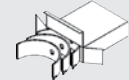



									
BE/PL	4	50.782/50.802	53.897/53.913	19.500	1.537	0.021/0.082	AL-LF	66240RA	<b>01-4175/4</b> STD 0.25 0.50 0.75 1.00
<b>01/75 →</b>									
MB/HL 1,2,4,5	4	52.985/53.005	56.717/56.730	20.750	1.841	0.030/0.088	AL-LF	66316RA	<b>H1043/5</b> STD 0.25 0.50 0.75
MB/HL 3	1	52.985/53.005	56.717/56.730	24.250	1.841	0.030/0.088	AL-LF	66317RA	
TW/A	2	59.000/59.250	73.600/73.850		2.362		BS	62037AF	<b>A201/2</b> STD .005
SE/PB	1	21.539/21.641	25.000/25.021	25.100			BS	66649Y	<b>55-4193</b> SEMI
SE/PB	1	21.539/21.641	23.939/23.972	25.100			BS	62039Y	<b>55-4288</b> SEMI
<b>07/84 →</b>									

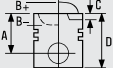
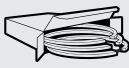

**892**  **80.00** **Petrol**   
**132 A.9000** 4 Cyl. 9:1 1592cc **70kW (95)PS** **TD21277** **147**











									
BE/PL	4	50.782/50.802	53.897/53.913	19.500	1.537	0.021/0.082	AL-LF	66240RA	<b>01-4175/4</b> STD 0.25 0.50 0.75 1.00
<b>01/75 →</b>									
MB/HL 1,2,4,5	4	52.985/53.005	56.717/56.730	20.750	1.841	0.030/0.088	AL-LF	66316RA	<b>H1043/5</b> STD 0.25 0.50 0.75
MB/HL 3	1	52.985/53.005	56.717/56.730	24.250	1.841	0.030/0.088	AL-LF	66317RA	
TW/A	2	59.000/59.250	73.600/73.850		2.362		BS	62037AF	<b>A201/2</b> STD .005
SE/PB	1	21.539/21.641	25.000/25.021	25.100			BS	66649Y	<b>55-4193</b> SEMI
SE/PB	1	21.539/21.641	23.939/23.972	25.100			BS	62039Y	<b>55-4288</b> SEMI
<b>07/84 →</b>									

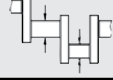

# FIAT GROUP







<b>893</b>	 <b>80.00</b>	<b>Petrol</b>	
132A.B.000-828	4 Cyl.	1592cc	<b>FM932</b>

			
	<b>08-203100-00</b> STD <b>08-203104-00</b> 0.20mm <b>08-203106-00</b> 0.40mm <b>08-203108-00</b> 0.60mm <b>08-203110-00</b> 0.80mm <b>08-203111-00</b> 1.00mm  1.50  CR P 2.00  P 3.95  P		

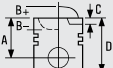
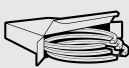
<b>894</b>	 <b>80.00</b>	<b>Petrol</b>	
132 AB.OA.0	4 Cyl.	9:1 1592cc	<b>72kW (98)PS</b> <b>TD21455</b>











									
BE/PL	4	50.782/50.802	53.897/53.913	19.500	1.537	0.021/0.082	AL-LF	66240RA	<b>01-4175/4</b> STD 0.25 0.50 0.75 1.00
<b>Mot.402353 →</b>									
MB/HL 1,2,4,5	4	52.985/53.005	56.717/56.730	20.750	1.841	0.030/0.088	AL-LF	66316RA	<b>H1043/5</b> STD 0.25 0.50 0.75
MB/HL 3	1	52.985/53.005	56.717/56.730	24.250	1.841	0.030/0.088	AL-LF	66317RA	
TW/A	2	59.000/59.250	73.600/73.850		2.362		BS	62037AF	<b>A201/2</b> STD .005
SE/PB	1	21.539/21.641	23.939/23.972	25.100			BS	62039Y	<b>55-4288</b> SEMI

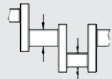
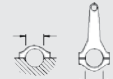

<b>895</b>	 <b>80.00</b>	<b>Petrol</b>	
132 AC.000	4 Cyl.	1592cc	<b>74-81kW (100-110)PS</b> <b>TD907 148</b>

			
	<b>08-203100-00</b> STD <b>08-203104-00</b> 0.20mm <b>08-203106-00</b> 0.40mm <b>08-203108-00</b> 0.60mm <b>08-203110-00</b> 0.80mm <b>08-203111-00</b> 1.00mm  1.50  CR P 2.00  P 3.95  P		





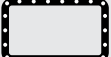
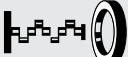





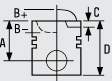
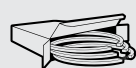





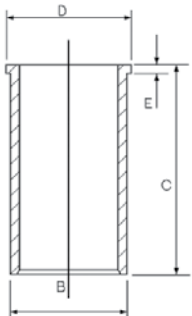

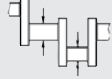
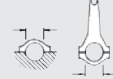

...Continued

<b>895</b>		 <b>80.00</b>	<b>Petrol</b>							
										
BE/PL	4	50.782/50.802	53.897/53.913	19.500	1.537	0.021/0.082	AL-LF	66240RA	<b>01-4175/4</b> STD 0.25 0.50 0.75 1.00	
MB/HL 1,2,4,5	4	52.985/53.005	56.717/56.730	20.750	1.841	0.030/0.088	AL-LF	66316RA	<b>H1043/5</b> STD 0.25 0.50 0.75	
MB/HL 3	1	52.985/53.005	56.717/56.730	24.250	1.841	0.030/0.088	AL-LF	66317RA		
TW/A	2	59.000/59.250	73.600/73.850		2.362		BS	62037AF	<b>A201/2</b> STD .005	
SE/PB	1	21.539/21.641	25.000/25.021	25.100			BS	66649Y	<b>55-4193</b> SEMI	
→06/84										
SE/PB	1	21.539/21.641	23.939/23.972	25.100			BS	62039Y	<b>55-4288</b> SEMI	
07/84 →										

		
<b>NA784</b>  70.00x90.00x10.00mm, ACM		

<b>896</b>		 <b>80.00</b>	<b>Petrol</b>							
<b>132 BB OA O</b>	<b>4 Cyl.</b>	<b>9:1</b>	<b>1592cc</b>	<b>71-72kW (97-98)PS</b>		<b>TD6825 149</b>				

			
	<p><b>08-203100-00</b> STD</p> <p><b>08-203104-00</b> 0.20mm</p> <p><b>08-203106-00</b> 0.40mm</p> <p><b>08-203108-00</b> 0.60mm</p> <p><b>08-203110-00</b> 0.80mm</p> <p><b>08-203111-00</b> 1.00mm</p> <p>1.50  CR P</p> <p>2.00  P</p> <p>3.95  P</p>	<p><b>14-028710-00 D</b></p> <p><b>B 86.53 C 125.10 D 95.00 E 7.80</b></p> 	

<b>896</b>		 <b>80.00</b>	<b>Petrol</b>							
										
BE/PL	4	50.782/50.802	53.897/53.913	19.500	1.537	0.021/0.082	AL-LF	66240RA	<b>01-4175/4</b> STD 0.25 0.50 0.75 1.00	
01/75 →										
MB/HL 1,2,4,5	4	52.985/53.005	56.717/56.730	20.750	1.841	0.030/0.088	AL-LF	66316RA	<b>H1043/5</b> STD 0.25 0.50 0.75	
MB/HL 3	1	52.985/53.005	56.717/56.730	24.250	1.841	0.030/0.088	AL-LF	66317RA		
TW/A	2	59.000/59.250	73.600/73.850		2.362		BS	62037AF	<b>A201/2</b> STD .005	
SE/PB	1	21.539/21.641	25.000/25.021	25.100			BS	66649Y	<b>55-4193</b> SEMI	
SE/PB	1	21.539/21.641	23.939/23.972	25.100			BS	62039Y	<b>55-4288</b> SEMI	

**896**  **80.00** **Petrol**

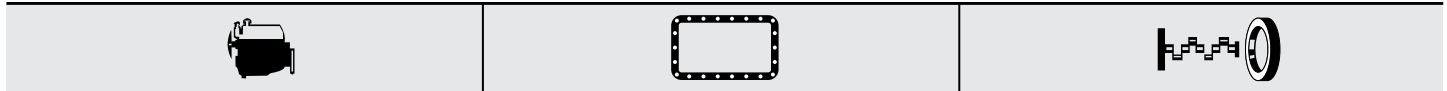

JH111

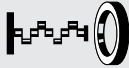
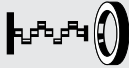
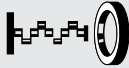
**NB818**  40.00x56.00x7.00mm, ACM  
**NA5050**  70.00x90.00x10.00mm, ACM  
**NA784**  70.00x90.00x10.00mm, ACM



JH111

**897**  **80.00** **Petrol** 

125 A.000	4 Cyl.	8.8:1	1608cc	66kW (90)PS	<b>TD878</b>	<b>150</b>
125 B.000	4 Cyl.	8.8:1	1608cc	74kW (100)PS	<b>TD879</b>	<b>151</b>

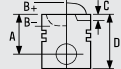
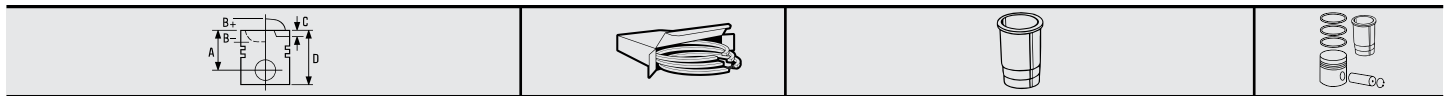







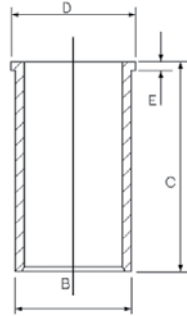

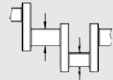
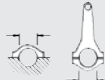

- 08-203100-00 STD
- 08-203104-00 0.20mm
- 08-203106-00 0.40mm
- 08-203108-00 0.60mm
- 08-203110-00 0.80mm
- 08-203111-00 1.00mm

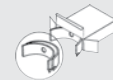

- 1.50  CR P
- 2.00  P
- 3.95  P

**14-028710-00 D**  
**B 86.53 C 125.10 D 95.00 E 7.80**





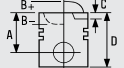
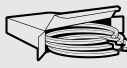

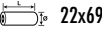
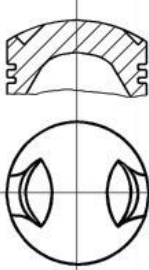
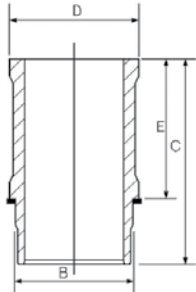





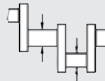
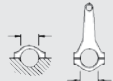

									
BE/PL	4	45.508/45.528	48.629/48.646	19.200	1.547	0.020/0.069	AL-LF	1645RA	<b>01-4127/4</b> STD 0.25 0.50
MB/HL 1,2,4,5	4	50.785/50.805	54.507/54.520	20.250	1.831	0.040/0.098	AL-LF	60986RA	<b>H1028/5</b> STD 0.25
MB/HL 3	1	50.785/50.805	54.507/54.520	22.750	1.831	0.040/0.098	AL-LF	60987RA	
TW/A	2	56.610/56.864	69.596/69.850		2.362		AL-LF	60987AFA	<b>A198/2</b> STD .005
SE/PB	1	21.539/21.641	23.939/23.972	25.100			BS	62039Y	<b>55-4288</b> SEMI

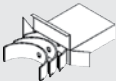

<b>898</b>	 <b>80.00</b>	<b>Petrol</b>			
AR 00548	4 Cyl.	1779cc	<b>83-97kW</b> (113-132)PS	TD18	<b>152</b>
AR 01608	4 Cyl.	1779cc	<b>87-89kW</b> (118-121)PS	TD5340	<b>154</b>
AR 01608 X	4 Cyl.	1779cc	<b>85kW</b> (115)PS	TD33	<b>155</b>
AR 01678	4 Cyl.	1779cc	<b>88-90kW</b> (120-122)PS	TD38	<b>154</b>
AR 06168	4 Cyl.	1779cc	<b>88kW</b> (120)PS	TD54	<b>157</b>
AR 06202	4 Cyl.	1779cc	<b>85-89kW</b> (116-121)PS	TD55	<b>157</b>
AR 61102	4 Cyl.	9:1	<b>88kW</b> (120)PS	TD10149	<b>157</b>



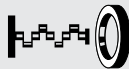





			
<b>87-528500-00</b> STD	<b>08-528500-00</b> STD	<b>15-632600-00 WH</b> [9] B 85.00 C 152.00 D 98.00 E 107.50	<b>89-528500-00</b> 87-528500-00 + 15-632600-00
A 33.25 B- 13.35 D 80.10  22x69	 1.50 1.75 3.50 CR P P P		

[9] Includes seals [9] Inclut des joints [9] Comprende le guarnizioni [9] Incluye los sellos

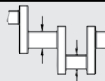
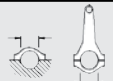
									
BE/PL	4	49.988/49.998	53.695/53.708	23.440	1.838	0.021/0.069	BS	60010CP	<b>71-4168/4</b> STD 0.25 0.50
MB/HL 1,3,5	3	59.960/59.973	63.657/63.676	25.530	1.837	0.020/0.067	BS	60011CP	<b>H1030/5</b> STD 0.25 0.50
MB/HL 2,4	2	59.960/59.973	63.657/63.676	18.360	1.837	0.020/0.067	BS	60012CP	
TW/A	4	65.786/66.040	82.423/82.677		2.362		AL-LF	2777AF	<b>A178/4</b> STD
SE/PB	1	21.994/22.000	25.120/25.146	23.720			BS	60014X	<b>55-4280</b> SEMI

		
		<b>NA5066</b>  35.00x50.00x10.00mm, ACM



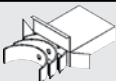





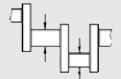

<b>899</b>	 <b>80.00</b>	<b>Petrol</b>				
AR 01354	4 Cyl.	1779cc	<b>110kW</b> (150)PS	<b>Turbocharged</b>	TD5343	<b>153</b>
AR 06134	4 Cyl.	1779cc	<b>110kW</b> (150)PS	<b>Turbocharged</b>	TD50	<b>156</b>
AR 06158	4 Cyl.	1779cc	<b>114kW</b> (155)PS	<b>Turbocharged</b>	TD52	<b>156</b>
AR 10548	4 Cyl.	9.5:1	<b>83-90kW</b> (113-122)PS		TD5350	
AR 61202	4 Cyl.	1779cc	<b>87-95kW</b> (118-129)PS		TD5333	<b>158</b>
AR 61203	4 Cyl.	1779cc	<b>110-121kW</b> (150-165)PS	<b>Turbo Intercooled</b>	TD23349	

									
BE/PL	4	49.988/49.998	53.695/53.708	23.440	1.838	0.021/0.069	BS	60010CP	<b>71-4168/4</b> STD 0.25 0.50
MB/HL 1,3,5	3	59.960/59.973	63.657/63.676	25.530	1.837	0.020/0.067	BS	60011CP	<b>H1030/5</b> STD 0.25 0.50
MB/HL 2,4	2	59.960/59.973	63.657/63.676	18.360	1.837	0.020/0.067	BS	60012CP	

# FIAT GROUP

...Continued

**899**  **80.00 Petrol**

									
TW/A	4	65.786/66.040	82.423/82.677		2.362		AL-LF	2777AF	<b>A178/4</b> STD
SE/PB	1	21.994/22.000	25.120/25.146	23.720			BS	60014X	<b>55-4280</b> SEMI

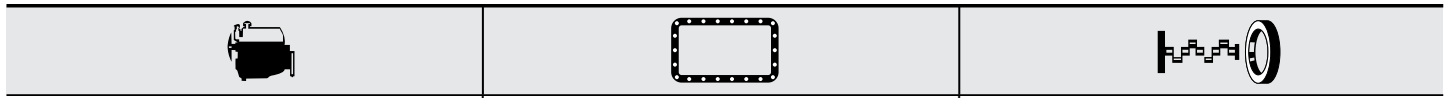

**JJ452** (MVQ) **NA5066**  35.00x50.00x10.00mm, ACM









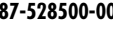
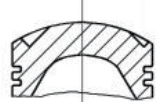

JJ452



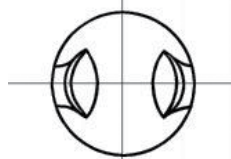



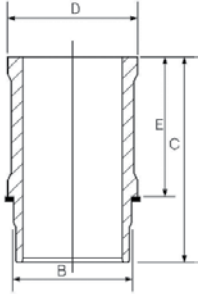

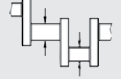

**900**  **80.00 Petrol** 

AR 61201 4 Cyl. 1779cc 90kW (122)PS TD103 158



	STD			STD		
<b>A</b> 33.25 <b>B-</b> 13.35 <b>D</b> 80.10 			1.50  CR P 1.75  P 3.50  P		<b>B</b> 85.00 <b>C</b> 152.00 <b>D</b> 98.00 <b>E</b> 107.50 	<b>89-528500-00</b> 87-528500-00 + 15-632600-00

[9] Includes seals [9] Inclut des joints [9] Comprende le guarnizioni [9] Incluye los sellos

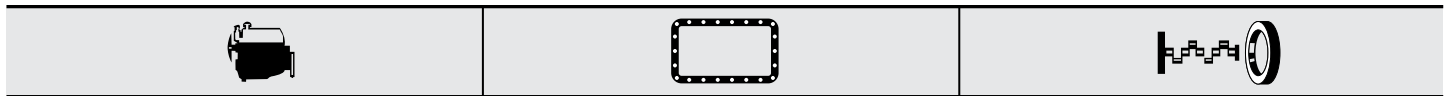

									
BE/PL	4	49.988/49.998	53.695/53.708	23.440	1.838	0.021/0.069	BS	60010CP	<b>71-4168/4</b> STD 0.25 0.50
MB/HL 1,3,5	3	59.960/59.973	63.657/63.676	25.530	1.837	0.020/0.067	BS	60011CP	<b>H1030/5</b> STD 0.25 0.50
MB/HL 2,4	2	59.960/59.973	63.657/63.676	18.360	1.837	0.020/0.067	BS	60012CP	
TW/A	4	65.786/66.040	82.423/82.677		2.362		AL-LF	2777AF	<b>A178/4</b> STD
SE/PB	1	21.994/22.000	25.120/25.146	23.720			BS	60014X	<b>55-4280</b> SEMI



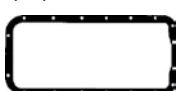







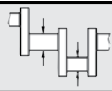
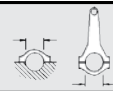

**JJ452** (MVQ) **NA5066**  35.00x50.00x10.00mm, ACM





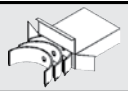





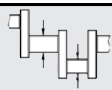
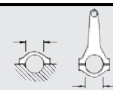

JJ452

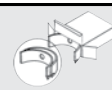
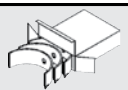

<b>901</b>			<b>80.00 Petrol</b>								
AR 16202	6 Cyl.	8:1	1996cc	148kW (202)PS	Turbo Intercooled	TD4189	159				
AR 34102	6 Cyl.	8:1	1996cc	151kW (205)PS	Turbo Intercooled	TD11600	160				









									
BE/PL	6	51.980/52.000	55.511/55.524	19.100	1.749	0.020/0.071	BS	4080CP	71-4218/6 STD 0.25
MB/HL 1-4	4	59.951/59.971	63.657/63.676	22.350	1.841	0.020/0.068	BS	4081CP	H1082/4 STD 0.25

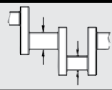
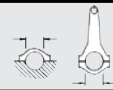

<b>902</b>			<b>80.00 Petrol</b>								
AR 64101	6 Cyl.	8:1	1996cc	150kW (204)PS	Turbocharged	TD5072	161				
AR 64102	6 Cyl.		1996cc	148-150kW (201-204)PS	Turbocharged	TD105	162				





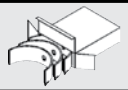

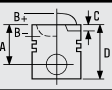
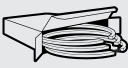

									
BE/PL	6	51.980/52.000	55.511/55.524	19.100	1.749	0.020/0.071	BS	4080CP	71-4218/6 STD 0.25
MB/HL 1-4	4	59.951/59.971	63.657/63.676	22.350	1.841	0.020/0.068	BS	4081CP	H1082/4 STD 0.25

		
<b>NA5104</b>  90.00x110.00x12.00mm, PTFE		

<b>903</b>			<b>80.00 Petrol</b>								
AR 01932	6 Cyl.		1997cc	99kW (135)PS		TD46					
AR 06210	6 Cyl.		1997cc	97kW (132)PS		TD56	163				

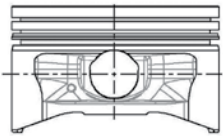



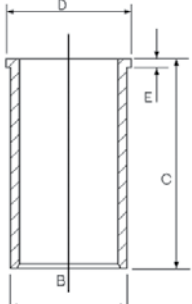







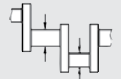

									
BE/PL	6	51.980/52.000	55.511/55.524	19.100	1.749	0.020/0.071	BS	4080CP	71-4218/6 STD 0.25
MB/HL 1-4	4	59.951/59.971	63.657/63.676	22.350	1.841	0.020/0.068	BS	4081CP	H1082/4 STD 0.25
SE/PB	1	21.994/22.000	25.120/25.146	23.720			BS	60014X	55-4280 SEMI







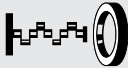

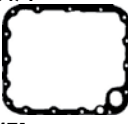



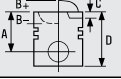





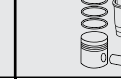
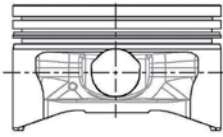
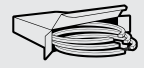

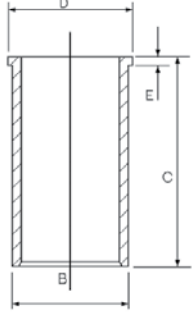





<b>904</b>			<b>80.00 Petrol</b>								
126 A2.000	2 Cyl.		704cc	19kW (26)PS		TD4342	164				
126 A2.048	2 Cyl.		704cc	19kW (26)PS		TD4344	164				



			
87-203106-10 87-203108-10	0.40mm 0.60mm	08-203100-00 STD 08-203104-00 0.20mm 08-203106-00 0.40mm 08-203108-00 0.60mm 08-203110-00 0.80mm 08-203111-00 1.00mm	14-028710-00 D B 86.53 C 125.10 D 95.00 E 7.80
A 34.00 D 60.00  20x54		1.50  CR P 2.00  P 3.95  P	

# FIAT GROUP



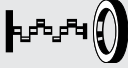
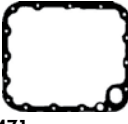



...Continued



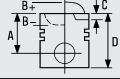
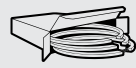

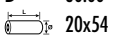

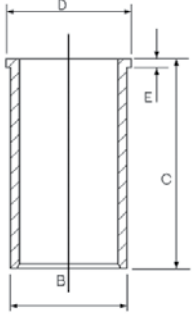

<b>904</b>		 <b>80.00</b>	<b>Petrol</b>							
										
BE/PL	2	44.013/44.033	47.130/47.142	19.200	1.543	0.011/0.068	AL-LF	60005RA	<b>01-4112/2</b> STD 0.25 0.50	
SE/PB	1	19.507/19.609	22.009/22.034	20.830			BS	60009X	<b>55-4210</b> SEMI	
										
			<b>JJ471</b>				<b>NA5045</b>  53.00x68.00x10.00mm, ACM			
										
			<b>JJ471</b>							

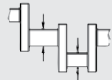
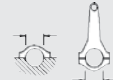

<b>905</b>		 <b>80.00</b>	<b>Petrol</b>							
<b>170 A.000</b>		<b>2 Cyl.</b>	<b>704cc</b>	<b>23kW (31)PS</b>				<b>TD1028</b>	<b>165</b>	
										
<b>87-203106-10</b>	<b>0.40mm</b>		<b>08-203100-00</b>	STD		<b>14-028710-00 D</b>				
<b>87-203108-10</b>	<b>0.60mm</b>		<b>08-203104-00</b>	0.20mm		<b>B 86.53 C 125.10 D 95.00 E 7.80</b>				
<b>A 34.00</b>		<b>08-203106-00</b>	0.40mm							
<b>D 60.00</b>		<b>08-203108-00</b>	0.60mm							
 <b>20x54</b>		<b>08-203110-00</b>	0.80mm							
		<b>08-203111-00</b>	1.00mm							
		<b>1.50</b>	 <b>CR P</b>							
		<b>2.00</b>	 <b>P</b>							
		<b>3.95</b>	 <b>P</b>							
										
BE/PL	2	44.013/44.033	47.130/47.142	19.200	1.543	0.011/0.068	AL-LF	60005RA	<b>01-4112/2</b> STD 0.25 0.50	
SE/PB	1	19.507/19.609	22.009/22.034	20.830			BS	60009X	<b>55-4210</b> SEMI	
										
			<b>JJ471</b>							
										
			<b>JJ471</b>							

**906**  **80.00** **Petrol** 

170 A.046      2 Cyl.      704cc      22kW (30)PS      TD15809      **165**

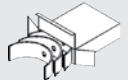





			
<b>87-203106-10</b> 0.40mm <b>87-203108-10</b> 0.60mm  <b>A</b> 34.00 <b>D</b> 60.00  20x54	<b>08-203100-00</b> STD <b>08-203104-00</b> 0.20mm <b>08-203106-00</b> 0.40mm <b>08-203108-00</b> 0.60mm <b>08-203110-00</b> 0.80mm <b>08-203111-00</b> 1.00mm  1.50  CR P 2.00  P 3.95  P	<b>14-028710-00 D</b> <b>B</b> 86.53 <b>C</b> 125.10 <b>D</b> 95.00 <b>E</b> 7.80  	



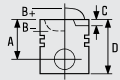
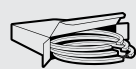





									
BE/PL	2	44.013/44.033	47.130/47.142	19.200	1.543	0.011/0.068	AL-LF	60005RA	<b>01-4112/2</b> STD 0.25 0.50
SE/PB	1	19.507/19.609	22.009/22.034	20.830			BS	60009X	<b>55-4210</b> SEMI



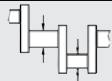
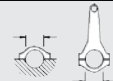

**907**  **80.50** **Petrol** 

146 A2.000      4 Cyl.      8:1      1301cc      77kW (105)PS      Turbo Intercooled      TD4373      **166**

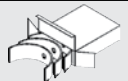
146 A2.246      4 Cyl.      1301cc      74kW (100)PS      Turbocharged      TD932      **167**

			
	<b>08-780700-00</b> STD  1.50  MOL P 2.00  P 3.95  CR P		

									
BE/PL	4	45.498/45.518	48.630/48.646	19.200	1.544	0.020/0.085	BS	1645CP	<b>71-4126/4</b> STD
MB/HL 1,2,4,5	4	50.780/50.800	54.507/54.520	20.250	1.849	0.020/0.067	AL-LF	1646RA	<b>H1075/5</b> STD 0.25 0.50
MB/HL 3	1	50.780/50.800	54.507/54.520	22.750	1.849	0.020/0.067	AL-LF	1647RA	
TW/A	2	56.610/56.864	69.596/69.850		2.362		AL-LF	60987AFA	<b>A198/2</b> STD .005
SE/PB	1	21.539/21.641	23.939/23.972	25.100			BS	62039Y	<b>55-4288</b> SEMI

		
		<b>NB818</b>  40.00x56.00x7.00mm, ACM

# FIAT GROUP

## 908

 80.50



Petrol



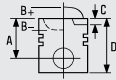







146 A2.146      4 Cyl.      1301cc      73kW (100)PS      Turbocharged      TD938      167

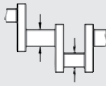
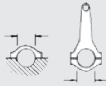

**08-780700-00**    STD

1.50  MOL P  
 2.00  P  
 3.95  CR P

									
BE/PL	4	45.498/45.518	48.630/48.646	19.200	1.544	0.020/0.085	BS	1645CP	<b>71-4126/4</b> STD
MB/HL 1,2,4,5	4	50.780/50.800	54.507/54.520	20.250	1.849	0.020/0.067	AL-LF	1646RA	<b>H1075/5</b> STD 0.25 0.50
MB/HL 3	1	50.780/50.800	54.507/54.520	22.750	1.849	0.020/0.067	AL-LF	1647RA	
TW/A	2	56.610/56.864	69.596/69.850		2.362		AL-LF	60987AFA	<b>A198/2</b> STD .005
SE/PB	1	21.539/21.641	23.939/23.972	25.100			BS	62039Y	<b>55-4288</b> SEMI

## 909

 80.50

Petrol







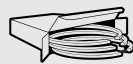
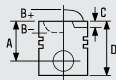





146 A8.000      4 Cyl.      7.8:1      1372cc      74-87kW (101-118)PS      Turbocharged      TD18372      168

146 A8.046      4 Cyl.      7.8:1      1372cc      82kW (112)PS      Turbocharged      TD944      169

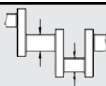
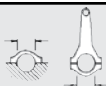

**08-524900-00**    STD

1.50  MOL P  
 2.00  P  
 3.00  CR P

									
BE/PL	4	45.508/45.528	48.629/48.646	19.200	1.547	0.020/0.069	AL-LF	1645RA	<b>01-4127/4</b> STD 0.25 0.50
MB/HL 1,2,4,5	4	50.780/50.800	54.507/54.520	20.250	1.849	0.020/0.067	AL-LF	1646RA	<b>H1075/5</b> STD 0.25 0.50
MB/HL 3	1	50.780/50.800	54.507/54.520	22.750	1.849	0.020/0.067	AL-LF	1647RA	
TW/A	2	56.610/56.864	69.596/69.850		2.362		AL-LF	60987AFA	<b>A198/2</b> STD .005
SE/PB	1	21.539/21.641	23.939/23.972	25.100			BS	62039Y	<b>55-4288</b> SEMI





ET400



JJ453





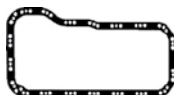







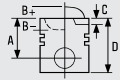

**NA5051**  40.00x56.00x7.00mm, FPM  
**NB818**  40.00x56.00x7.00mm, ACM  
**NB808**  64.00x80.00x8.00mm, FPM











JJ453



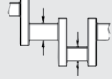
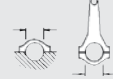



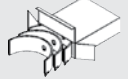

<b>910</b>	 <b>80.50</b>	<b>Petrol</b>				
<b>146 C1.000</b>	4 Cyl.	9.2:1	1372cc	<b>51-53kW (69-72)PS</b>	<b>TD18821</b>	<b>170</b>
<b>146 C5.000</b>	4 Cyl.	9.2:1	1372cc	<b>49-52kW (67-71)PS</b>	<b>TD6816</b>	<b>171</b>
<b>146 D5.000</b>	4 Cyl.	9.2:1	1372cc	<b>49kW (67)PS</b>	<b>TD6817</b>	<b>171</b>
<b>178 B2.000</b>	4 Cyl.	9.2:1	1372cc	<b>51kW (69)PS</b>	<b>TD16173</b>	<b>176</b>
<b>178 B2.016</b>	4 Cyl.	9.2:1	1372cc	<b>51kW (69)PS</b>	<b>TD16174</b>	<b>177</b>

			
	<p><b>08-783600-00</b> STD</p> <p><b>08-783606-00</b> 0.40mm</p> <p><b>08-783608-00</b> 0.60mm</p> <p><b>08-783610-00</b> 0.80mm</p> <p><b>08-783611-00</b> 1.00mm</p> <p>1.50  CR P</p> <p>1.75  P</p> <p>3.00  CR [15]</p> <p><b>08-786700-00</b> STD</p> <p>01/95→</p> <p>1.20  CR [15]</p> <p>1.50  P</p> <p>3.00  P</p>		

[15] Steel      [15] Acier      [15] Acciaio      [15] Acero

									
BE/PL	4	45.508/45.528	48.629/48.646	19.200	1.547	0.020/0.069	AL-LF	1645RA	<b>01-4127/4</b> STD 0.25 0.50
MB/HL 1,2,4,5	4	50.780/50.800	54.507/54.520	20.250	1.849	0.020/0.067	AL-LF	1646RA	<b>H1075/5</b> STD 0.25 0.50
MB/HL 3	1	50.780/50.800	54.507/54.520	22.750	1.849	0.020/0.067	AL-LF	1647RA	
TW/A	2	56.610/56.864	69.596/69.850		2.362		AL-LF	60987AFA	<b>A198/2</b> STD .005
SE/PB	1	21.539/21.641	23.939/23.972	25.100			BS	62039Y	<b>55-4288</b> SEMI

		
<b>ET400</b>	<b>JJ453</b>	<b>NA5051</b>  40.00x56.00x7.00mm, FPM
		<b>NB818</b>  40.00x56.00x7.00mm, ACM
	<b>JJ453</b>	<b>NB808</b>  64.00x80.00x8.00mm, FPM







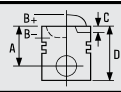
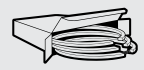

## 911

 **80.50**

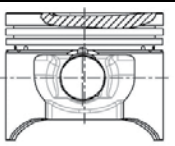
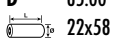
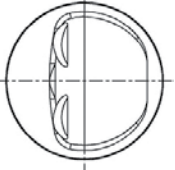





**Petrol**



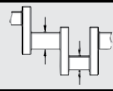
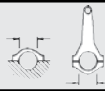

<b>159 A2.000</b>	4 Cyl.	9.2:1	1372cc	<b>57kW (78)PS</b>	<b>TD9728</b>	<b>172</b>
<b>160 A1.000</b>	4 Cyl.	9.2:1	1372cc	<b>52-56kW (71-76)PS</b>	<b>TD1015</b>	<b>172</b>

								
<b>87-783600-00</b> <b>87-783606-00</b> <b>87-783608-00</b>	STD 0.40mm 0.60mm		<b>08-783600-00</b> <b>08-783606-00</b> <b>08-783608-00</b> <b>08-783610-00</b> <b>08-783611-00</b>	STD 0.40mm 0.60mm 0.80mm 1.00mm				
<b>A</b> 33.30 <b>B-</b> 2.90 <b>D</b> 65.00  22x58			1.50  CR P 1.75  P 3.00  CR [15]					
			<b>08-786700-00</b> STD 01/95→					
			1.20  CR [15] 1.50  P 3.00  P					

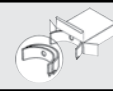
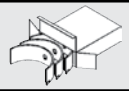

[15] Steel      [15] Acier      [15] Acciaio      [15] Acero

									
BE/PL	4	45.508/45.528	48.629/48.646	19.200	1.547	0.020/0.069	AL-LF	1645RA	<b>01-4127/4</b> STD 0.25 0.50
MB/HL 1,2,4,5	4	50.780/50.800	54.507/54.520	20.250	1.849	0.020/0.067	AL-LF	1646RA	<b>H1075/5</b> STD 0.25 0.50
MB/HL 3	1	50.780/50.800	54.507/54.520	22.750	1.849	0.020/0.067	AL-LF	1647RA	
TW/A	2	56.610/56.864	69.596/69.850		2.362		AL-LF	60987AFA	<b>A198/2</b> STD .005
SE/PB	1	21.539/21.641	23.939/23.972	25.100			BS	62039Y	<b>55-4288</b> SEMI

		
---	---	---



**ET400**



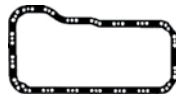



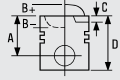
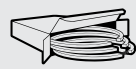

**JJ453**

**NB818**  40.00x56.00x7.00mm, ACM  
**NA5049**  64.00x80.00x8.00mm, ACM

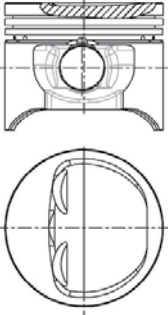
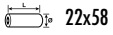











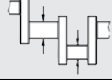
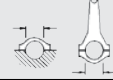





**JJ453**

<b>912</b>	 <b>80.50</b>	<b>Petrol</b>				
<b>160 A1.046</b>	4 Cyl.	9.2:1	1372cc	<b>49-51kW (67-69)PS</b>	<b>TD1016</b>	<b>173</b>
<b>160 A1.048</b>	4 Cyl.	9.2:1	1372cc	<b>50-52kW (69-71)PS</b>	<b>TD4393</b>	<b>174</b>
<b>836 A4.000</b>	4 Cyl.	9.2:1	1372cc	<b>51kW (69)PS</b>	<b>TD893</b>	<b>172</b>

							
<b>87-783600-00</b> <b>87-783606-00</b> <b>87-783608-00</b>	STD 0.40mm 0.60mm		<b>08-783600-00</b> STD <b>08-783606-00</b> 0.40mm <b>08-783608-00</b> 0.60mm <b>08-783610-00</b> 0.80mm <b>08-783611-00</b> 1.00mm				
<b>A</b> 33.30 <b>B-</b> 2.90 <b>D</b> 65.00  22x58			1.50  CR P 1.75  P 3.00  CR [15]				
			<b>08-786700-00</b> STD 01/95→				
			1.20  CR [15] 1.50  P 3.00  P				

[15] Steel                      [15] Acier                      [15] Acciaio                      [15] Acero

									
BE/PL	4	45.508/45.528	48.629/48.646	19.200	1.547	0.020/0.069	AL-LF	1645RA	<b>01-4127/4</b> STD 0.25 0.50
MB/HL 1,2,4,5	4	50.780/50.800	54.507/54.520	20.250	1.849	0.020/0.067	AL-LF	1646RA	<b>H1075/5</b> STD 0.25 0.50
MB/HL 3	1	50.780/50.800	54.507/54.520	22.750	1.849	0.020/0.067	AL-LF	1647RA	
TW/A	2	56.610/56.864	69.596/69.850		2.362		AL-LF	60987AFA	<b>A198/2</b> STD .005
SE/PB	1	21.539/21.641	23.939/23.972	25.100			BS	62039Y	<b>55-4288</b> SEMI

		
<b>ET400</b>	<b>JJ453</b>	<b>NA5051</b>  40.00x56.00x7.00mm, FPM <b>NB818</b>  40.00x56.00x7.00mm, ACM <b>NB808</b>  64.00x80.00x8.00mm, FPM
	 <b>JJ453</b>	

<b>913</b>	<b>80.50</b>	<b>Petrol</b>	
<b>160 A1.046</b>	4 Cyl.	9.2:1	1372cc
			<b>51kW (69)PS</b>
			<b>TD4599 173</b>

<b>87-783600-00</b> STD <b>87-783606-00</b> 0.40mm <b>87-783608-00</b> 0.60mm  <b>A</b> 33.30 <b>B-</b> 2.90 <b>D</b> 65.00 22x58	<b>08-783600-00</b> STD <b>08-783606-00</b> 0.40mm <b>08-783608-00</b> 0.60mm <b>08-783610-00</b> 0.80mm <b>08-783611-00</b> 1.00mm  1.50  CR P 1.75  P 3.00  CR [15]		
	<b>08-786700-00</b> STD  1.20  CR [15] 1.50  P 3.00  P		

[15] Steel      [15] Acier      [15] Acciaio      [15] Acero









BE/PL	MB/HL 1,2,4,5	MB/HL 3	TW/A	SE/PB					
4	4	1	2	1					
45.508/45.528	50.780/50.800	50.780/50.800	56.610/56.864	21.539/21.641					
48.629/48.646	54.507/54.520	54.507/54.520	69.596/69.850	23.939/23.972					
19.200	20.250	22.750	2.362	25.100					
1.547	1.849	1.849							
0.020/0.069	0.020/0.067	0.020/0.067							
AL-LF	AL-LF	AL-LF	AL-LF	BS					
1645RA	1646RA	1647RA	60987AFA	62039Y					
<b>01-4127/4</b>	<b>H1075/5</b>	<b>A198/2</b>	<b>55-4288</b>						
STD 0.25 0.50	STD 0.25 0.50	STD .005	SEMI						

<b>ET400</b>	<b>JJ453</b>	<b>NB818</b> 40.00x56.00x7.00mm, ACM
		<b>NA5049</b> 64.00x80.00x8.00mm, ACM
	<b>JJ453</b>	

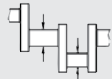
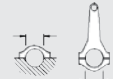
<b>914</b>	<b>80.50</b>	<b>Petrol</b>	
<b>176 A4.000</b>	4 Cyl.	7.8:1	1372cc
			<b>96-98kW (131-136)PS</b>
			<b>Turbo Intercooled</b>
			<b>TD1034 175</b>
<b>176 B6.000</b>	4 Cyl.	7.8:1	1372cc
			<b>96kW (131)PS</b>
			<b>Turbo Intercooled</b>
			<b>TD5492 175</b>

	<b>08-524900-00</b> STD  1.50  MOL P 2.00  P 3.00  CR P		

...Continued

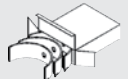
<b>914</b>	 <b>80.50</b>	<b>Petrol</b>							
									
BE/PL	4	45.508/45.528	48.629/48.646	19.200	1.547	0.020/0.069	AL-LF	1645RA	<b>01-4127/4</b> STD 0.25 0.50
MB/HL 1,2,4,5	4	50.780/50.800	54.507/54.520	20.250	1.849	0.020/0.067	AL-LF	1646RA	<b>H1075/5</b> STD 0.25 0.50
MB/HL 3	1	50.780/50.800	54.507/54.520	22.750	1.849	0.020/0.067	AL-LF	1647RA	
TW/A	2	56.610/56.864	69.596/69.850		2.362		AL-LF	60987AFA	<b>A198/2</b> STD .005
SE/PB	1	21.539/21.641	23.939/23.972	25.100			BS	62039Y	<b>55-4288</b> SEMI

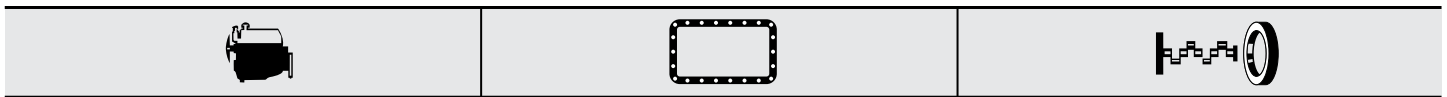

**ET400**

**JJ453**

**NB818** [19] 40.00x56.00x7.00mm, ACM  
**NF887** [19] 64.00x112.50x20.00mm, FPM



**JJ453**





[19] Specification: Oil Seal in housing

[19] Caractéristiques: Bague d'étanchéité dans son logement

[19] Specifiche: Paraoilio in sede

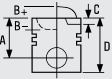
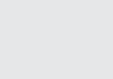
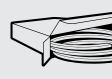
[19] Especificaciones: Retén de aceite de la carcasa

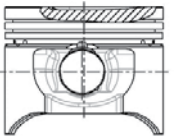
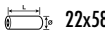
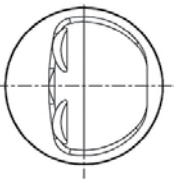
<b>915</b>	 <b>80.50</b>	<b>Petrol</b>								
<b>836 A4.000</b>	4 Cyl.	9.2:1	1372cc	<b>51kW (69)PS</b>	<b>TD14568</b>	<b>178</b>				









				
<b>87-783600-00</b> <b>87-783606-00</b> <b>87-783608-00</b>	STD 0.40mm 0.60mm		<b>08-783600-00</b> <b>08-783606-00</b> <b>08-783608-00</b> <b>08-783610-00</b> <b>08-783611-00</b>	STD 0.40mm 0.60mm 0.80mm 1.00mm
<b>A</b> 33.30 <b>B-</b> 2.90 <b>D</b> 65.00  22x58			<b>CR P</b> <b>P</b> <b>CR [15]</b>	
			<b>08-786700-00</b>	STD <b>CR [15]</b> <b>P</b> <b>P</b>

[15] Steel

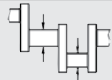
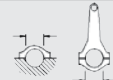
[15] Acier

[15] Acciaio

[15] Acero

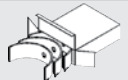







									
BE/PL	4	45.508/45.528	48.629/48.646	19.200	1.547	0.020/0.069	AL-LF	1645RA	<b>01-4127/4</b> STD 0.25 0.50
MB/HL 1,2,4,5	4	50.780/50.800	54.507/54.520	20.250	1.849	0.020/0.067	AL-LF	1646RA	<b>H1075/5</b> STD 0.25 0.50
MB/HL 3	1	50.780/50.800	54.507/54.520	22.750	1.849	0.020/0.067	AL-LF	1647RA	
TW/A	2	56.610/56.864	69.596/69.850		2.362		AL-LF	60987AFA	<b>A198/2</b> STD .005

# FIAT GROUP

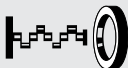
...Continued

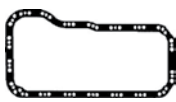







## 915 80.50 Petrol

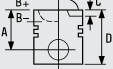
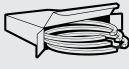



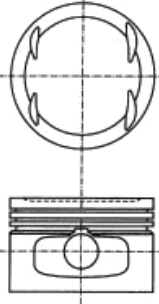





SE/PB	1	21.539/21.641	23.939/23.972	25.100		BS	62039Y	55-4288 SEMI
-------	---	---------------	---------------	--------	--	----	--------	-----------------

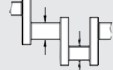





		
 ET400	JJ453  JJ453	<b>NA5051</b>  40.00x56.00x7.00mm, FPM <b>NB818</b>  40.00x56.00x7.00mm, ACM <b>NB808</b>  64.00x80.00x8.00mm, FPM

## 916 80.50 Petrol

182 B6.000	4 Cyl.	10.1:1	1596cc	76kW (103)PS	TD15632	180
182 B6.000	4 Cyl.	10.5:1	1596cc	68-100kW (92-136)PS	TD16166	181

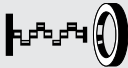



			
<b>87-124800-00</b> STD <b>87-124806-00</b> 0.40mm  <b>A</b> 28.65 <b>B-</b> 1.20 <b>BØ</b> 62.00 <b>C</b> 2.49 <b>C</b> 1.98 <b>D</b> 50.65  21x56	 <b>08-124800-00</b> STD <b>08-124806-00</b> 0.40mm <b>08-124808-00</b> 0.60mm  1.20  NT P 1.20  P 2.00  P		







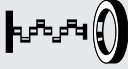

									
BE/PL	4	45.508/45.528	48.629/48.646	19.200	1.547	0.020/0.069	AL-LF	1645RA	<b>01-4127/4</b> STD 0.25 0.50
MB/HL 1,2,4,5	4	50.780/50.800	54.507/54.520	20.250	1.849	0.020/0.067	AL-LF	1646RA	<b>H1075/5</b> STD 0.25 0.50
MB/HL 3	1	50.780/50.800	54.507/54.520	22.750	1.849	0.020/0.067	AL-LF	1647RA	
TW/A	2	56.610/56.864	69.596/69.850		2.362		AL-LF	60987AFA	<b>A198/2</b> STD .005
SE/PB	1	21.539/21.641	23.939/23.972	25.100			BS	62039Y	<b>55-4288</b> SEMI

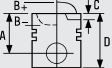
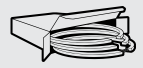

			
 EB5150	HR397	<b>NA5051</b>  40.00x56.00x7.00mm, FPM <b>NB818</b>  40.00x56.00x7.00mm, ACM <b>NF887</b>  [19] 64.00x112.50x20.00mm, FPM	
[19] Specification: Oil Seal in housing	[19] Caractéristiques: Bague d'étanchéité dans son logement	[19] Specifiche: Paraolio in sede	[19] Especificaciones: Retén de aceite de la carcasa



## 917 80.50 Petrol



939 A4.000	4 Cyl.	1796cc	96-103kW (131-140)PS	TD20262	182
------------	--------	--------	----------------------	---------	-----

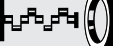

		
 EH5240	HR397	<b>NA5174</b>  31.50x42.00x7.00mm, FPM





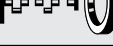





<b>918</b>	 <b>80.50</b>	<b>Petrol</b>	
<b>939 A4.000</b>	4 Cyl.	1796cc	<b>96-103kW (131-140)PS</b>
			
	<b>08-141200-00</b> STD <b>08-141207-00</b> 0.50mm  1.20  NT [15] 1.20  P 2.00  CR [15]		

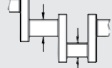

[15] Steel	[15] Acier	[15] Acciaio	[15] Acero
			
<b>EH5240</b>	<b>HR397</b>	<b>NA5174</b>  31.50x42.00x7.00mm, FPM	









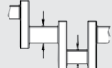

<b>919</b>	 <b>80.50</b>	<b>Petrol</b>	
<b>93313090-7U</b>	4 Cyl.	10.5:1	1796cc
<b>93313090-H2</b>	4 Cyl.	10.5:1	1796cc
<b>93337154-J1</b>	4 Cyl.	10.5:1	1796cc
<b>J2</b>	4 Cyl.	10.5:1	1796cc
<b>PN93327668</b>	4 Cyl.	9.4:1	1796cc
<b>PN93327669</b>	4 Cyl.	9.8:1	1796cc
<b>Y2</b>	4 Cyl.	10.5:1	1796cc
			<b>78-84kW (106-114)PS</b>
			<b>83-85kW (113-116)PS</b>
			<b>82-84kW (112-112)PS</b>
			<b>83-85kW (113-115)PS</b>
			<b>76-77kW (103-105)PS</b>
			<b>90kW (122)PS</b>
			<b>83-85kW (113-115)PS</b>
			<b>TD24992</b>
			<b>TD25004</b>
			<b>TD25021</b>
			<b>TD25017</b>
			<b>TD24998</b>
			<b>TD25025</b>
			<b>TD25019</b>

			
		<b>NB698</b>  80.00x98.00x10.00mm, FPM	













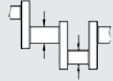
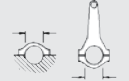

<b>920</b>	 <b>80.50</b>	<b>Petrol</b>	
<b>199 B6.000 Euro 6</b>	2 Cyl.	10.1:1	875cc
<b>199 B6.000 Euro 6</b>	2 Cyl.	10.1:1	875cc
			<b>74-77kW (101-105)PS</b>
			<b>74-77kW (101-105)PS</b>
			<b>Turbo Intercooled</b>
			<b>Turbo Intercooled</b>
			<b>TD26735</b>
			<b>TD27856</b>















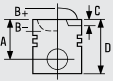
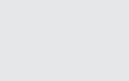

									
SE/PB	1		23.939/23.972	22.070			BS-LF	55-4970	<b>55-4970</b> SEMI



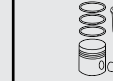
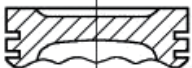

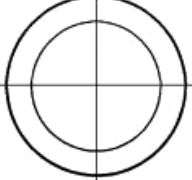









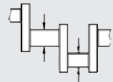
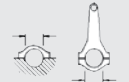

<b>921</b>	 <b>80.50</b>	<b>Petrol</b>	
<b>312 A2.000 Euro 5</b>	2 Cyl.	10:1	875cc
			<b>63kW (86)PS</b>
			<b>Turbo Intercooled</b>
			<b>TD26187</b>

									
TW/A	2	53.100/53.300	68.766/69.020		2.335	0.105/0.275	AL-LF	04-4969	<b>A321/2</b> STD
SE/PB	1		23.939/23.972	22.070			BS-LF	55-4970	<b>55-4970</b> SEMI

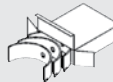
# FIAT GROUP

<b>922</b>		 <b>80.50</b>	<b>Petrol</b>							
<b>312 A2.000 Euro 5</b>	2 Cyl.	10.2:1	875cc	<b>57-63kW (77-86)PS</b>	<b>Turbo Intercooled</b>	<b>TD24763</b>				
<b>312 A2.000 Euro 5</b>	2 Cyl.	10:1	875cc	<b>59-63kW (80-86)PS</b>	<b>Turbo Intercooled</b>	<b>TD25191</b>				
										
TW/A	2	53.100/53.300	68.766/69.020		2.335	0.105/0.275	AL-LF	04-4969	<b>A321/2</b> STD	
SE/PB	1		23.939/23.972	22.070			BS-LF	55-4970	<b>55-4970</b> SEMI	
										
							<b>NA5070</b>  31.00x41.00x7.00mm, FPM			

<b>923</b>		 <b>82.00</b>	<b>Petrol</b>							
<b>182 A3.000</b>	4 Cyl.	9.8:1	1370cc	<b>59kW (80)PS</b>	<b>TD4399</b>	<b>184</b>				
<b>182 A5.000</b>	4 Cyl.	9.8:1	1370cc	<b>55kW (75)PS</b>	<b>TD4401</b>	<b>185</b>				
<b>840 A2.000</b>	4 Cyl.	9.85:1	1370cc	<b>55-59kW (75-80)PS</b>	<b>TD1858</b>	<b>186</b>				
<b>840 A4.000</b>	4 Cyl.	9.85:1	1370cc	<b>55kW (75)PS</b>	<b>TD4596</b>	<b>186</b>				
										
<b>87-787000-30</b> <b>87-787006-30</b>	STD 0.40mm		<b>08-787000-00</b> <b>08-787006-00</b>	STD 0.40mm						
<b>A</b> 34.11 <b>B-</b> 5.10 <b>D</b> 58.11  20x52			1.50  CR P 1.50  P 3.00  CR [15]							
[15] Steel	[15] Acier	[15] Acciaio	[15] Acero							

<b>923</b>		 <b>82.00</b>	<b>Petrol</b>							
										
BE/PL	4	40.870/40.890	44.000/44.012	19.100	1.543	0.024/0.081	AL-LF	4400RA	<b>01-4160/4</b> STD 0.25	
MB/HL 1,2,4,5	4	52.982/53.000	56.705/56.718	20.750	1.843	0.019/0.075	AL-LF	4351RA	<b>H1096/5</b> STD 0.25 0.50	
MB/HL 3	1	52.982/53.000	56.705/56.718	20.750	1.838	0.029/0.085	AL-LF	4352RA		
TW/A	2	58.808/59.062	73.486/73.740		2.485		AL-LF	4351AF	<b>A190/2</b> STD	
SE/PB	1	19.993/20.000	22.939/22.972	21.700			BS	4359Y	<b>55-4540</b> SEMI	
										
			<b>HR397</b>				<b>NA5070</b>  31.00x41.00x7.00mm, FPM <b>NF888</b>  93.00x172.00x12.00mm, FPM			



<b>924</b>	<b>82.00</b>	<b>Petrol</b>	
<b>AR 33503</b>	4 Cyl.	10.5:1	1370cc <b>76kW (103)PS</b> <b>TD9752</b> <b>187</b>
<b>AR 38501</b>	4 Cyl.		1370cc <b>76kW (103)PS</b> <b>TD9753</b> <b>187</b>

<b>87-787000-10</b> STD <b>87-787006-10</b> 0.40mm  <b>A</b> 34.46 <b>B+</b> 4.90 <b>D</b> 63.36 20x52	<b>08-787000-00</b> STD <b>08-787006-00</b> 0.40mm  1.50  CR P 1.50  P 3.00  CR [15]		
[15] Steel	[15] Acier	[15] Acciaio	[15] Acero

BE/PL	4	40.870/40.890	44.000/44.012	19.100	1.543	0.024/0.081	AL-LF	4400RA	<b>01-4160/4</b> STD 0.25
BE/PL	4	40.870/40.890	44.000/44.012	19.100	1.543		EC	71-3996	<b>71-3996/4</b> STD
<b>02/00</b> →									
MB/HL 1,2,4,5	4	52.982/53.000	56.705/56.718	20.750	1.843	0.019/0.075	AL-LF	4351RA	<b>H1096/5</b> STD 0.25 0.50
MB/HL 3	1	52.982/53.000	56.705/56.718	20.750	1.838	0.029/0.085	AL-LF	4352RA	
TW/A	2	58.808/59.062	73.486/73.740		2.485		AL-LF	4351AF	<b>A190/2</b> STD
SE/PB	1	19.993/20.000	22.939/22.972	21.700			BS	4359Y	<b>55-4540</b> SEMI

	<b>HR397</b>		
		<b>NA5070</b> 31.00x41.00x7.00mm, FPM	<b>NF888</b> 93.00x172.00x12.00mm, FPM

<b>925</b>	<b>82.00</b>	<b>Petrol</b>	
<b>AR 32101</b>	4 Cyl.	10.5:1	1598cc <b>88kW (120)PS</b> <b>TD9461</b> <b>188</b>

BE/PL	4	40.870/40.890	44.000/44.012	19.100	1.543		EC	71-3996	<b>71-3996/4</b> STD
<b>02/00</b> →									
BE/PL	4	48.226/48.244	51.354/51.366	19.100	1.543	0.020/0.080	BS	4355CP	<b>71-4158/4</b> STD 0.25
MB/HL 1,2,4,5	4	52.982/53.000	56.705/56.718	20.750	1.843	0.019/0.075	AL-LF	4351RA	<b>H1096/5</b> STD 0.25 0.50
MB/HL 3	1	52.982/53.000	56.705/56.718	20.750	1.838	0.029/0.085	AL-LF	4352RA	
TW/A	2	58.808/59.062	73.486/73.740		2.485		AL-LF	4351AF	<b>A190/2</b> STD
SE/PB	1	19.993/20.000	22.939/22.972	21.700			BS	4359Y	<b>55-4540</b> SEMI

## 926

### 82.00

### Petrol



AR 32102	4 Cyl.	1598cc	<b>82-88kW</b> (112-120)PS	TD14369	<b>189</b>
AR 38201	4 Cyl.	1598cc	<b>88kW</b> (120)PS	TD9754	<b>192</b>
AR 67601	4 Cyl.	10.3:1 1598cc	<b>88kW</b> (120)PS	TD19	<b>193</b>







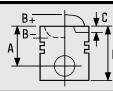
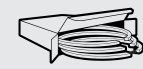

<b>87-118000-10</b> <b>87-118006-10</b>  STD 0.40mm  A 32.90 B+ 1.80 C 1.90 D 56.70 20x52			<b>08-118000-00</b> STD <b>08-118006-00</b> 0.40mm <b>08-118008-00</b> 0.60mm  1.19  NT 1.20  P 2.00  P				

BE/PL	4	40.870/40.890	44.000/44.012	19.100	1.543		EC	71-3996	<b>71-3996/4</b> STD
<b>02/00 →</b>									
BE/PL	4	48.226/48.244	51.354/51.366	19.100	1.543	0.020/0.080	BS	4355CP	<b>71-4158/4</b> STD 0.25
MB/HL 1,2,4,5	4	52.982/53.000	56.705/56.718	20.750	1.843	0.019/0.075	AL-LF	4351RA	<b>H1096/5</b> STD 0.25 0.50
MB/HL 3	1	52.982/53.000	56.705/56.718	20.750	1.838	0.029/0.085	AL-LF	4352RA	
TW/A	2	58.808/59.062	73.486/73.740		2.485		AL-LF	4351AF	<b>A190/2</b> STD
SE/PB	1	19.993/20.000	22.939/22.972	21.700			BS	4359Y	<b>55-4540</b> SEMI

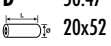
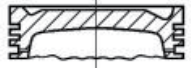
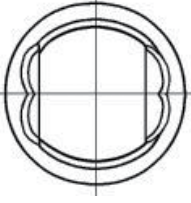









	HR397	<b>NA5070</b> 31.00x41.00x7.00mm, FPM <b>NF888</b> 93.00x172.00x12.00mm, FPM





**927**  **82.00** **Petrol** 

<b>AR 32103 D4</b>	4 Cyl.	1598cc	<b>88kW (120)PS</b>	<b>TD15389</b>	<b>190</b>
<b>AR 32104</b>	4 Cyl.	1598cc	<b>88kW (120)PS</b>	<b>TD15388</b>	<b>190</b>

			
<b>87-145400-30</b> STD <b>87-145406-30</b> 0.40mm	<b>08-145400-00</b> STD <b>08-145406-00</b> 0.40mm		
<b>A</b> 28.47 <b>B+</b> 0.20 <b>C</b> 1.88 <b>D</b> 50.47  20x52	  	1.20  NT [15] 1.20  P 2.00  P  <b>08-118000-00</b> STD <b>08-118006-00</b> 0.40mm <b>08-118008-00</b> 0.60mm  1.19  NT 1.20  P 2.00  P	

[15] Steel                      [15] Acier                      [15] Acciaio                      [15] Acero

										
BE/PL	4	40.870/40.890	44.000/44.012	19.100	1.543		EC	71-3996	<b>71-3996/4</b> STD	
<b>02/00 →</b>										
BE/PL	4	48.226/48.244	51.354/51.366	19.100	1.543	0.020/0.080	BS	4355CP	<b>71-4158/4</b> STD 0.25	
MB/HL 1,2,4,5	4	52.982/53.000	56.705/56.718	20.750	1.843	0.019/0.075	AL-LF	4351RA	<b>H1096/5</b> STD 0.25 0.50	
MB/HL 3	1	52.982/53.000	56.705/56.718	20.750	1.838	0.029/0.085	AL-LF	4352RA		
TW/A	2	58.808/59.062	73.486/73.740		2.485		AL-LF	4351AF	<b>A190/2</b> STD	
SE/PB	1	19.993/20.000	22.939/22.972	21.700			BS	4359Y	<b>55-4540</b> SEMI	

		
<b>EA5420</b>	<b>HR397</b>	<b>NA5070</b>  31.00x41.00x7.00mm, FPM <b>NF888</b>  93.00x172.00x12.00mm, FPM

**928**

**82.00**

**Petrol**



AR 37203      4 Cyl.      1598cc      76kW (103)PS      TD15508      191



<p><b>87-145400-00</b>      STD <b>87-145406-00</b>      0.40mm</p> <p>A 28.47 B- 0.30 D 50.47 20x51</p>		<p><b>08-145400-00</b>      STD <b>08-145406-00</b>      0.40mm</p> <p>1.20      NT [15] 1.20      P 2.00      P</p> <p><b>08-118000-00</b>      STD <b>08-118006-00</b>      0.40mm <b>08-118008-00</b>      0.60mm</p> <p>1.19      NT 1.20      P 2.00      P</p>		









[15] Steel      [15] Acier      [15] Acciaio      [15] Acero

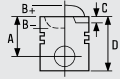



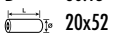
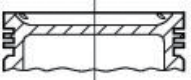
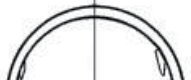





--	--	--	--	--	--	--	--	--	--

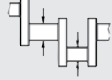
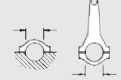

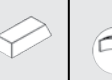

BE/PL	4	40.870/40.890	44.000/44.012	19.100	1.543		EC	71-3996	<b>71-3996/4</b> STD
<b>02/00</b> →									
BE/PL	4	48.226/48.244	51.354/51.366	19.100	1.543	0.020/0.080	BS	4355CP	<b>71-4158/4</b> STD 0.25
MB/HL 1,2,4,5	4	52.982/53.000	56.705/56.718	20.750	1.843	0.019/0.075	AL-LF	4351RA	<b>H1096/5</b> STD 0.25 0.50
MB/HL 3	1	52.982/53.000	56.705/56.718	20.750	1.838	0.029/0.085	AL-LF	4352RA	
TW/A	2	58.808/59.062	73.486/73.740		2.485		AL-LF	4351AF	<b>A190/2</b> STD
SE/PB	1	19.993/20.000	22.939/22.972	21.700			BS	4359Y	<b>55-4540</b> SEMI



<p><b>EA5420</b></p>	<p><b>HR397</b></p>	<p><b>NA5070</b> 31.00x41.00x7.00mm, FPM <b>NF888</b> 93.00x172.00x12.00mm, FPM</p>









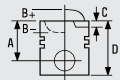

<b>929</b>		<b>82.00</b>	<b>Petrol</b>			
<b>182 A2.000</b>	4 Cyl.	10.3:1	1747cc	<b>83kW (113)PS</b>	<b>TD4398</b>	<b>194</b>
<b>182 A2.000</b>	4 Cyl.	10:1	1747cc	<b>83kW (113)PS</b>	<b>TD9473</b>	<b>195</b>
<b>183 A1.000</b>	4 Cyl.	10.3:1	1747cc	<b>92-97kW (125-132)PS</b>	<b>TD4405</b>	<b>197</b>
<b>839 A4.000</b>	4 Cyl.		1747cc	<b>96kW (131)PS</b>	<b>TD14468</b>	<b>200</b>

			
<b>87-118000-00</b> <b>87-118006-00</b>  <b>A</b> 36.15 <b>B-</b> 0.50 <b>D</b> 60.15  20x52	STD 0.40mm    	<b>08-118000-00</b> STD <b>08-118006-00</b> 0.40mm <b>08-118008-00</b> 0.60mm  1.19  NT 1.20  P 2.00  P	

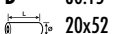
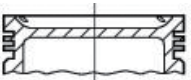
										
BE/PL	4	50.787/50.807	53.901/53.913	19.500	1.534	0.028/0.083	BS	4350CP	<b>71-4157/4</b> STD 0.25 0.50	
MB/HL 1,2,4,5	4	52.982/53.000	56.705/56.718	20.750	1.843	0.019/0.075	AL-LF	4351RA	<b>H1096/5</b> STD 0.25 0.50	
MB/HL 3	1	52.982/53.000	56.705/56.718	20.750	1.838	0.029/0.085	AL-LF	4352RA		
TW/A	2	58.808/59.062	73.486/73.740		2.485		AL-LF	4351AF	<b>A190/2</b> STD	
SE/PB	1	19.993/20.000	22.939/22.972	21.700			BS	4359Y	<b>55-4540</b> SEMI	











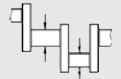

		
HR397	NA5070  31.00x41.00x7.00mm, FPM	NF888  93.00x172.00x12.00mm, FPM

<b>930</b>		<b>82.00</b>	<b>Petrol</b>			
<b>183 A1.000</b>	4 Cyl.	10.3:1	1747cc	<b>96kW (131)PS</b>	<b>TD9474</b>	<b>196</b>



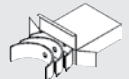

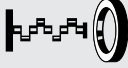

			
<b>87-118000-00</b> <b>87-118006-00</b>  <b>A</b> 36.15 <b>B-</b> 0.50 <b>D</b> 60.15  20x52	STD 0.40mm    	<b>08-118000-00</b> STD <b>08-118006-00</b> 0.40mm <b>08-118008-00</b> 0.60mm  1.19  NT 1.20  P 2.00  P	

# FIAT GROUP

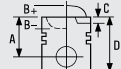
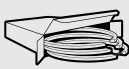















...Continued



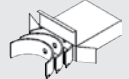











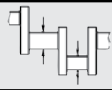

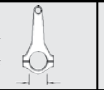

<b>930</b>		 <b>82.00</b>	<b>Petrol</b>							
										
BE/PL	4	50.787/50.807	53.901/53.913	19.500	1.534	0.028/0.083	BS	4350CP	<b>71-4157/4</b> STD 0.25 0.50	
MB/HL 1,2,4,5	4	52.982/53.000	56.705/56.718	20.750	1.843	0.019/0.075	AL-LF	4351RA	<b>H1096/5</b> STD 0.25 0.50	
MB/HL 3	1	52.982/53.000	56.705/56.718	20.750	1.838	0.029/0.085	AL-LF	4352RA		
TW/A	2	58.808/59.062	73.486/73.740		2.485		AL-LF	4351AF	<b>A190/2</b> STD	
SE/PB	1	19.993/20.000	22.939/22.972	21.700			BS	4359Y	<b>55-4540</b> SEMI	
										
EA5420			HR397				NA5070  31.00x41.00x7.00mm, FPM NF888  93.00x172.00x12.00mm, FPM			

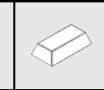

<b>931</b>		 <b>82.00</b>	<b>Petrol</b>						
<b>188 A6.000</b>	4 Cyl.	10.3:1	1747cc	<b>96kW (130)PS</b>			<b>TD16408</b>	<b>198</b>	
<b>192 A4.000</b>	4 Cyl.	10.3:1	1747cc	<b>96-98kW (130-133)PS</b>			<b>TD16395</b>	<b>199</b>	
<b>839 A7.000</b>	4 Cyl.	10.3:1	1747cc	<b>96kW (131)PS</b>			<b>TD15633</b>	<b>201</b>	









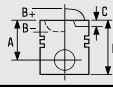
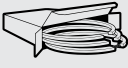

			
	<b>08-145400-00</b> STD <b>08-145406-00</b> 0.40mm  1.20  NT [15] 1.20  P 2.00 		

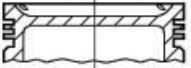
[15] Steel      [15] Acier      [15] Acciaio      [15] Acero



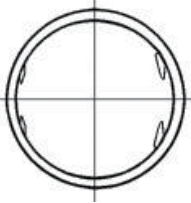





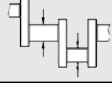

<b>931</b>		 <b>82.00</b>	<b>Petrol</b>							
										
BE/PL	4	50.787/50.807	53.901/53.913	19.500	1.534	0.028/0.083	BS	4350CP	<b>71-4157/4</b> STD 0.25 0.50	
MB/HL 1,2,4,5	4	52.982/53.000	56.705/56.718	20.750	1.843	0.019/0.075	AL-LF	4351RA	<b>H1096/5</b> STD 0.25 0.50	
MB/HL 3	1	52.982/53.000	56.705/56.718	20.750	1.838	0.029/0.085	AL-LF	4352RA		
TW/A	2	58.808/59.062	73.486/73.740		2.485		AL-LF	4351AF	<b>A190/2</b> STD	
SE/PB	1	19.993/20.000	22.939/22.972	21.700			BS	4359Y	<b>55-4540</b> SEMI	
										
EA5420			HR397				NA5070  31.00x41.00x7.00mm, FPM NF888  93.00x172.00x12.00mm, FPM			

<b>932</b>		 <b>82.00</b>	<b>Petrol</b>							
<b>839 A9.000</b>		4 Cyl.	10.3:1	1747cc	<b>96kW (131)PS</b>			<b>TD17508</b>		<b>202</b>
										
BE/PL	4	50.787/50.807	53.901/53.913	19.500	1.534	0.028/0.083	BS	4350CP	<b>71-4157/4</b> STD 0.25 0.50	
MB/HL 1,2,4,5	4	52.982/53.000	56.705/56.718	20.750	1.843	0.019/0.075	AL-LF	4351RA	<b>H1096/5</b> STD 0.25 0.50	
MB/HL 3	1	52.982/53.000	56.705/56.718	20.750	1.838	0.029/0.085	AL-LF	4352RA		
TW/A	2	58.808/59.062	73.486/73.740		2.485		AL-LF	4351AF	<b>A190/2</b> STD	
SE/PB	1	19.993/20.000	22.939/22.972	21.700			BS	4359Y	<b>55-4540</b> SEMI	
										
EA5420			HR397			NA5070  31.00x41.00x7.00mm, FPM NF888  93.00x172.00x12.00mm, FPM				

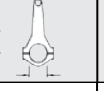
<b>933</b>		 <b>82.00</b>	<b>Petrol</b>							
<b>AR 32201</b>		4 Cyl.	10.3:1	1747cc	<b>106kW (144)PS</b>			<b>TD9462</b>		<b>203</b>
<b>AR 32205</b>		4 Cyl.		1747cc	<b>103kW (140)PS</b>			<b>TD15390</b>		<b>204</b>
<b>AR 38401</b>		4 Cyl.	10.3:1	1747cc	<b>103kW (140)PS</b>			<b>TD9755</b>		<b>205</b>
<b>AR 67106</b>		4 Cyl.	10.3:1	1747cc	<b>103kW (140)PS</b>			<b>TD5070</b>		<b>206</b>

										
<b>87-118000-00</b>	STD				<b>08-118000-00</b>	STD				
<b>87-118006-00</b>	0.40mm				<b>08-118006-00</b>	0.40mm				
					<b>08-118008-00</b>	0.60mm				
<b>A</b>	36.15				1.19		NT			
<b>B-</b>	0.50				1.20		P			
<b>D</b>	60.15				2.00		P			
	20x52									
										
					<b>08-145400-00</b>	STD				
					<b>08-145406-00</b>	0.40mm				
					1.20		NT [15]			
					1.20		P			
					2.00					

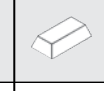



[15] Steel      [15] Acier      [15] Acciaio      [15] Acero

										
BE/PL	4	50.787/50.807	53.901/53.913	19.500	1.534	0.028/0.083	BS	4350CP	<b>71-4157/4</b> STD 0.25 0.50	
MB/HL 1,2,4,5	4	52.982/53.000	56.705/56.718	20.750	1.843	0.019/0.075	AL-LF	4351RA	<b>H1096/5</b> STD 0.25 0.50	
MB/HL 3	1	52.982/53.000	56.705/56.718	20.750	1.838	0.029/0.085	AL-LF	4352RA		
TW/A	2	58.808/59.062	73.486/73.740		2.485		AL-LF	4351AF	<b>A190/2</b> STD	
SE/PB	1	19.993/20.000	22.939/22.972	21.700			BS	4359Y	<b>55-4540</b> SEMI	

# FIAT GROUP



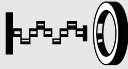







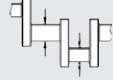

...Continued

## 933 82.00 **Petrol**

		
<b>EA5420</b>	<b>HR397</b>	<b>NA5070</b>  31.00x41.00x7.00mm, FPM <b>NF888</b>  93.00x172.00x12.00mm, FPM

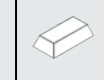



## 934 82.00 **Petrol**

**AR 67199** 4 Cyl. 10.3:1 1747cc **103kW (140)PS** **TD23350** **207**

											
BE/PL	4	50.787/50.807	53.901/53.913	19.500	1.534	0.028/0.083	BS	4350CP	<b>71-4157/4</b> STD 0.25 0.50		
MB/HL 1,2,4,5	4	52.982/53.000	56.705/56.718	20.750	1.843	0.019/0.075	AL-LF	4351RA	<b>H1096/5</b> STD 0.25 0.50		
MB/HL 3	1	52.982/53.000	56.705/56.718	20.750	1.838	0.029/0.085	AL-LF	4352RA			
TW/A	2	58.808/59.062	73.486/73.740		2.485		AL-LF	4351AF	<b>A190/2</b> STD		
SE/PB	1	19.993/20.000	22.939/22.972	21.700			BS	4359Y	<b>55-4540</b> SEMI		

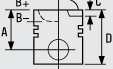
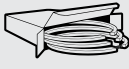
## 935 82.00 **Diesel**

**605 D** 4 Cyl. 20:1 1901cc **40kW (54)PS** **FM19243**

			
<p>[12]</p> <p><b>A</b> 47.00</p> <p><b>B-</b> 3.80</p> <p><b>D</b> 100.00</p> <p> 26x72</p>	<p>[14]</p> <p>3.00</p> <p>3.00</p> <p>3.00</p> <p>5.50</p> <p>5.00</p> <p><b>CR</b></p>	<p><b>WH [10]</b></p> <p><b>B</b> 89.00 <b>C</b> 164.80 <b>D</b> 95.00 <b>E</b> 99.60 <b>F</b> 0.80</p>	<b>88-530300-00</b>

[10] Liner available in Kit Set only

[12] Piston available in Kit Set only

[14] Ringset available in Kitset only

[10] Chemise disponible en kit seulement

[12] Chemise disponible en kit seulement

[14] Jeux de segments disponible en kit seulement.

[10] Cilindro disponibile solo in kit motore

[12] I pistoni sono disponibili solo in kit motore



[14] I set anelli piston sono disponibili solo in kit motore







[10] Camisas disponible en conjuntos solamente.



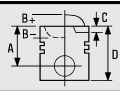
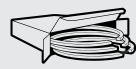



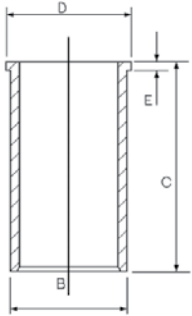

[12] Pistón disponible en conjuntos solamente.



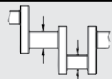
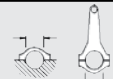

[14] Juegos de segmentos disponible en conjuntos solamente.



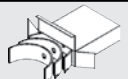







<b>936</b>	 <b>82.00</b>	<b>Diesel</b>					
<b>182 A7.000</b>	4 Cyl.	20.7:1	1910cc	<b>74kW (100)PS</b>	<b>Turbo Intercooled</b>	<b>TD4403</b>	<b>208</b>
<b>182 A8.000</b>	4 Cyl.	20.7:1	1910cc	<b>55kW (75)PS</b>	<b>Turbo Intercooled</b>	<b>TD4404</b>	<b>209</b>



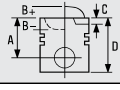
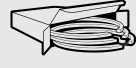





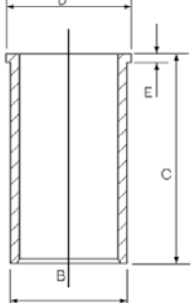

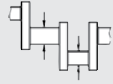

			
<b>87-523100-00</b> STD <b>87-523108-00</b> 0.60mm  <b>A</b> 45.20 <b>B-</b> 2.15 <b>D</b> 71.15  26x65  <b>AK RT</b>	<b>08-523100-00</b> STD <b>08-523108-00</b> 0.60mm  <b>3.00</b>  <b>CK P</b> <b>2.00</b>  <b>P</b> <b>3.00</b>  <b>CR P</b>	<b>14-021051-00 D</b> <b>B</b> 85.57 <b>C</b> 155.00 <b>D</b> 88.53 <b>E</b> 4.00 <b>14-028960-00 D</b> <b>B</b> 85.00 <b>C</b> 155.00 <b>D</b> 88.00 <b>E</b> 4.50  	





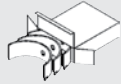

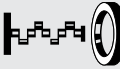







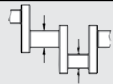

									
BE/PL	4	50.787/50.807	53.901/53.913	19.500	1.534	0.028/0.083	BS	4350CP	<b>71-4157/4</b> STD 0.25 0.50
MB/HL 1,2,4,5	4	52.982/53.000	56.705/56.718	20.750	1.843	0.019/0.075	AL-LF	4351RA	<b>H1096/5</b> STD 0.25 0.50
MB/HL 3	1	52.982/53.000	56.705/56.718	20.750	1.838	0.029/0.085	AL-LF	4352RA	
TW/A	2	58.808/59.062	73.486/73.740		2.485		AL-LF	4351AF	<b>A190/2</b> STD
SE/PB	1		28.939/28.972	21.700			BS	4369Y	<b>55-4159</b> SEMI

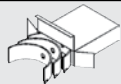

		
	<b>HR397</b>	<b>NA5070</b>  31.00x41.00x7.00mm, FPM <b>NF888</b>  93.00x172.00x12.00mm, FPM

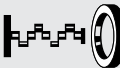





<b>937</b>	 <b>82.00</b>	<b>Diesel</b>					
<b>182 B4.000</b>	4 Cyl.	18.45:1	1910cc	<b>77-79kW (105-107)PS</b>	<b>Turbo Intercooled</b>	<b>TD11168</b>	<b>210</b>
<b>AR 32302</b>	4 Cyl.	18.5:1	1910cc	<b>77kW (105)PS</b>	<b>Turbocharged</b>	<b>TD17398</b>	<b>254</b>
<b>AR 32302</b>	4 Cyl.	18.5:1	1910cc	<b>77kW (105)PS</b>	<b>Turbocharged</b>	<b>TD9769</b>	<b>253</b>



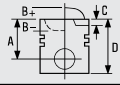
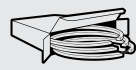

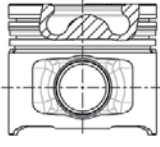
			
<b>87-108000-00</b> STD <b>87-108008-00</b> 0.60mm  <b>A</b> 47.25 <b>B-</b> 17.50 <b>BØ</b> 37.45 <b>D</b> 73.25  26x61  <b>AK NB RT</b>	<b>08-108000-00</b> STD <b>08-108008-00</b> 0.60mm  <b>3.00</b>  <b>CK P</b> <b>2.00</b>  <b>P</b> <b>3.00</b>  <b>CR P</b>	<b>14-021051-00 D</b> <b>B</b> 85.57 <b>C</b> 155.00 <b>D</b> 88.53 <b>E</b> 4.00 <b>14-028960-00 D</b> <b>B</b> 85.00 <b>C</b> 155.00 <b>D</b> 88.00 <b>E</b> 4.50  	



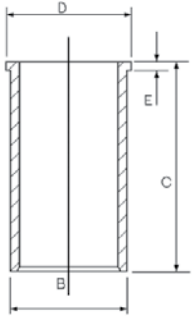

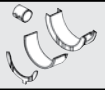
<b>937</b>		 <b>82.00</b>	<b>Diesel</b>							
										
BE/PL	1	50.787/50.805	53.901/53.913	19.500	1.534	0.030/0.080	EC	71-3994	<b>71-3994</b> STD 0.25 [22]	
MB/HL 1-5	5	59.986/60.000	63.705/63.718	20.750	1.844	0.031/0.075	BS	4356CP	<b>H1095/5</b> STD 0.25 0.50	
TW/A	2	67.785/68.040	82.425/82.677		2.485		AL-LF	4356AF	<b>A191/2</b> STD	
SE/PB	1		28.939/28.972	21.700			BS	4369Y	<b>55-4159</b> SEMI	
										
			HR397				<b>NA5070</b>  31.00x41.00x7.00mm, FPM <b>NF888</b>  93.00x172.00x12.00mm, FPM			

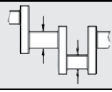
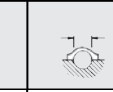
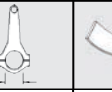

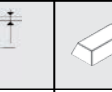
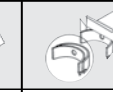
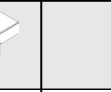
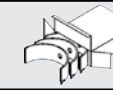
<b>938</b>		 <b>82.00</b>	<b>Diesel</b>							
<b>182 B9.000 Euro 3 (D3)</b>	4 Cyl.	18.45:1	1910cc	<b>74-77kW (101-105)PS</b>			<b>Turbo Intercooled</b>	<b>TD18312</b>	<b>212</b>	
<b>223 B1.000</b>	4 Cyl.	18.5:1	1910cc	<b>77kW (105)PS</b>			<b>Turbo Intercooled</b>	<b>TD20245</b>	<b>232</b>	
<b>223 B2.000</b>	4 Cyl.	18.5:1	1910cc	<b>74kW (100)PS</b>			<b>Turbo Intercooled</b>	<b>TD20246</b>	<b>233</b>	
										
BE/PL	1	50.787/50.805	53.901/53.913	19.500	1.534	0.030/0.080	EC	71-3994	<b>71-3994</b> STD 0.25 [22]	
MB/HL 1-5	5	59.986/60.000	63.705/63.718	20.750	1.844	0.031/0.075	BS	4356CP	<b>H1095/5</b> STD 0.25 0.50	
TW/A	2	67.785/68.040	82.425/82.677		2.485		AL-LF	4356AF	<b>A191/2</b> STD	
SE/PB	1		28.939/28.972	21.700			BS	4369Y	<b>55-4159</b> SEMI	
										
 EE5181			HR397				<b>NA5070</b>  31.00x41.00x7.00mm, FPM <b>NF888</b>  93.00x172.00x12.00mm, FPM			







<b>939</b>	 <b>82.00</b>	<b>Diesel</b>					
<b>182 B9.000 Euro 3 (D3)</b>	4 Cyl.	18.45:1	1910cc	<b>74-77kW (100-105)PS</b>	<b>Turbo Intercooled</b>	<b>TD16399</b>	<b>211</b>
<b>186 A8.000</b>	4 Cyl.		1910cc	<b>85kW (115)PS</b>	<b>Turbo Intercooled</b>	<b>TD18309</b>	<b>214</b>

			
<b>87-124000-30</b> <b>87-124008-30</b>  STD 0.60mm  A 46.50 B- 17.45 BØ 37.55 C 0.65 D 72.50 26x61  NB RT	  	<b>08-124000-00</b> STD <b>08-124006-00</b> 0.40mm <b>08-124008-00</b> 0.60mm 06/00 →  2.00  CK P 2.00  P 2.00  CR P	<b>14-021051-00 D</b> B 85.57 C 155.00 D 88.53 E 4.00 <b>14-028960-00 D</b> B 85.00 C 155.00 D 88.00 E 4.50  

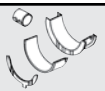
										
BE/PL	1	50.787/50.805	53.901/53.913	19.500	1.534	0.030/0.080	EC	71-3994	<b>71-3994</b> STD 0.25	[22]
MB/HL 1-5	5	59.986/60.000	63.705/63.718	20.750	1.844	0.031/0.075	BS	4356CP	<b>H1095/5</b> STD 0.25 0.50	
TW/A	2	67.785/68.040	82.425/82.677		2.485		AL-LF	4356AF	<b>A191/2</b> STD	
SE/PB	1		28.939/28.972	21.700			BS	4369Y	<b>55-4159</b> SEMI	

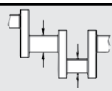
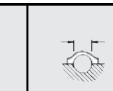
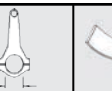
		
<b>EE5181</b>	<b>HR397</b>	<b>NA5070</b>  31.00x41.00x7.00mm, FPM <b>NF888</b>  93.00x172.00x12.00mm, FPM

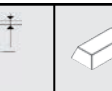
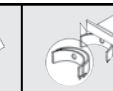
<b>940</b>	 <b>82.00</b>	<b>Diesel</b>					
<b>185 B4.000</b>	4 Cyl.	18.45:1	1910cc	<b>77kW (105)PS</b>	<b>Turbo Intercooled</b>	<b>TD23359</b>	

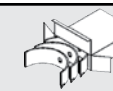
										
BE/PL	1	50.787/50.805	53.901/53.913	19.500	1.534	0.030/0.080	EC	71-3994	<b>71-3994</b> STD 0.25	[22]
MB/HL 1-5	5	59.986/60.000	63.705/63.718	20.750	1.844	0.031/0.075	BS	4356CP	<b>H1095/5</b> STD 0.25 0.50	
TW/A	2	67.785/68.040	82.425/82.677		2.485		AL-LF	4356AF	<b>A191/2</b> STD	
SE/PB	1		28.939/28.972	21.700			BS	4369Y	<b>55-4159</b> SEMI	

## 941

### 82.00

### Diesel



<b>186 A6.000</b>	4 Cyl.	18.45:1	1910cc	<b>81kW (110)PS</b>	<b>Turbo Intercooled</b>	<b>TD15831</b>	<b>213</b>
<b>188 A2.000</b>	4 Cyl.	18.4:1	1910cc	<b>59kW (80)PS</b>	<b>Turbo Intercooled</b>	<b>TD12788</b>	<b>216</b>
<b>188 A7.000</b>	4 Cyl.	18.5:1	1910cc	<b>63kW (86)PS</b>	<b>Turbo Intercooled</b>	<b>TD16409</b>	<b>218</b>
<b>192 A3.000</b>	4 Cyl.	18.5:1	1910cc	<b>59kW (80)PS</b>	<b>Turbo Intercooled</b>	<b>TD16397</b>	<b>222</b>

<p><b>87-107900-00</b> STD <b>87-107908-00</b> 0.60mm</p> <p>A 46.50 B- 17.50 BØ 37.50 C 0.80 D 72.50 26x65</p> <p><b>AK RT</b></p>	<p><b>08-107900-00</b> STD <b>08-107908-00</b> 0.60mm →06/00</p> <p>2.50 CR P 2.00 P 2.00 CR P</p>	<p><b>14-021051-00 D</b> B 85.57 C 155.00 D 88.53 E 4.00 <b>14-028960-00 D</b> B 85.00 C 155.00 D 88.00 E 4.50</p>	
<p><b>87-124000-10 [13]</b> STD <b>87-124008-10</b> 0.60mm</p> <p>A 46.50 B- 17.50 BØ 37.50 C 0.55 D 72.50 26x65</p> <p><b>AK RT</b></p>	<p><b>08-124000-00</b> STD <b>08-124006-00</b> 0.40mm <b>08-124008-00</b> 0.60mm 06/00→</p> <p>2.00 CK P 2.00 P 2.00 CR P</p>		

[13] Piston Chamber Volume [ccm] 19.91



[13] Volume de la cavité du piston [cm³] 19.91







[13] Volume camera pistone [cm³] 19.91



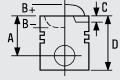
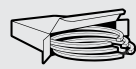









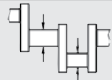

[13] Volumen de cavidad del pistón [cc] 19.91





BE/PL	1	50.787/50.805	53.901/53.913	19.500	1.534	0.030/0.080	EC	71-3994	<b>71-3994</b> STD 0.25	[22]
MB/HL 1-5	5	59.986/60.000	63.705/63.718	20.750	1.844	0.031/0.075	BS	4356CP	<b>H1095/5</b> STD 0.25 0.50	
TW/A	2	67.785/68.040	82.425/82.677		2.485		AL-LF	4356AF	<b>A191/2</b> STD	
SE/PB	1		28.939/28.972	21.700			BS	4369Y	<b>55-4159</b> SEMI	



<b>EE5181</b>	<b>HR397</b>	<b>NA5070</b> 31.00x41.00x7.00mm, FPM <b>NF888</b> 93.00x172.00x12.00mm, FPM



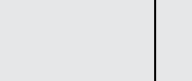
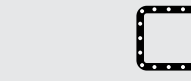





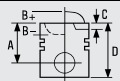
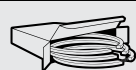

<b>942</b>	 <b>82.00</b>	<b>Diesel</b>	
<b>186 A9.000</b>	4 Cyl.	1910cc	<b>88kW (120)PS</b>
<b>188 B2.000</b>	4 Cyl.	18:1	<b>74kW (101)PS</b>
<b>223 A7.000</b>	4 Cyl.	18.5:1	<b>77kW (105)PS</b>
			<b>Turbo Intercooled</b>
			<b>TD19306</b>
			<b>215</b>

			
	<b>08-124000-00</b> STD <b>08-124006-00</b> 0.40mm <b>08-124008-00</b> 0.60mm  2.00  CK P 2.00  P 2.00  CR P		

														[22]
BE/PL	1	50.787/50.805	53.901/53.913	19.500	1.534	0.030/0.080	EC	71-3994	71-3994 STD 0.25	H1095/5 STD 0.25 0.50	A191/2 STD	55-4159 SEMI		
MB/HL 1-5	5	59.986/60.000	63.705/63.718	20.750	1.844	0.031/0.075	BS	4356CP						
TW/A	2	67.785/68.040	82.425/82.677		2.485		AL-LF	4356AF						
SE/PB	1		28.939/28.972	21.700			BS	4369Y						





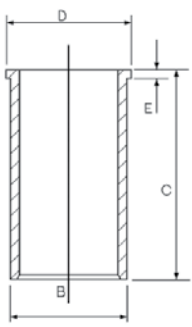







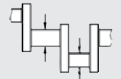
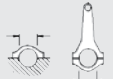

			
EE5181	HR397	NA5070  31.00x41.00x7.00mm, FPM	NF888  93.00x172.00x12.00mm, FPM











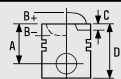





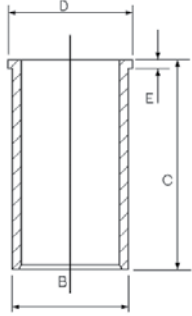

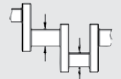
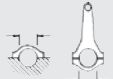

<b>943</b>	 <b>82.00</b>	<b>Diesel</b>	
<b>188 A3.000</b>	4 Cyl.	22.5:1	<b>44kW (60)PS</b>
			<b>TD12789</b>
			<b>217</b>



			
<b>87-124000-00</b> STD <b>87-124008-00</b> 0.60mm  A 44.45 B- 2.60 D 70.40  26x65  RT	<b>08-124000-00</b> STD <b>08-124006-00</b> 0.40mm <b>08-124008-00</b> 0.60mm 06/00 →  2.00  CK P 2.00  P 2.00  CR P  <b>08-107900-00</b> STD <b>08-107908-00</b> 0.60mm →06/00  2.50  CR P 2.00  P 2.00  CR P	<b>14-021051-00 D</b> B 85.57 C 155.00 D 88.53 E 4.00 <b>14-028960-00 D</b> B 85.00 C 155.00 D 88.00 E 4.50  	









# FIAT GROUP

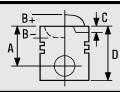
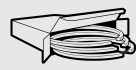



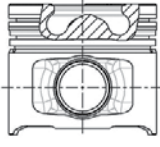

...Continued

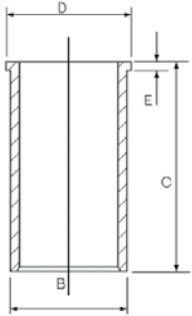

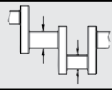
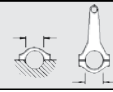

<b>943</b>		 <b>82.00</b>	<b>Diesel</b>							
										
BE/PL	4	50.787/50.807	53.901/53.913	19.500	1.534	0.028/0.083	BS	4350CP	<b>71-4157/4</b> STD 0.25 0.50	
MB/HL 1,2,4,5	4	52.982/53.000	56.705/56.718	20.750	1.843	0.019/0.075	AL-LF	4351RA	<b>H1096/5</b> STD 0.25 0.50	
MB/HL 3	1	52.982/53.000	56.705/56.718	20.750	1.838	0.029/0.085	AL-LF	4352RA		
TW/A	2	58.808/59.062	73.486/73.740		2.485		AL-LF	4351AF	<b>A190/2</b> STD	
										
			HR397				<b>NA5070</b>  31.00x41.00x7.00mm, FPM <b>NF888</b>  93.00x172.00x12.00mm, FPM			

<b>944</b>		 <b>82.00</b>	<b>Diesel</b>							
<b>188 B2.000</b>		4 Cyl.	18:1	1910cc	<b>74kW (101)PS</b>		<b>Turbo Intercooled</b>		<b>TD18316</b>	<b>219</b>
										
			<b>08-124000-00</b> STD <b>08-124006-00</b> 0.40mm <b>08-124008-00</b> 0.60mm  2.00  CK P 2.00  P 2.00  CR P	<b>14-021051-00 D</b> <b>B 85.57 C 155.00 D 88.53 E 4.00</b>  <b>14-028960-00 D</b> <b>B 85.00 C 155.00 D 88.00 E 4.50</b>						
										
BE/PL	1	50.787/50.805	53.901/53.913	19.500	1.534	0.030/0.080	EC	71-3994	<b>71-3994</b> STD 0.25 [22]	
MB/HL 1-5	5	59.986/60.000	63.705/63.718	20.750	1.844	0.031/0.075	BS	4356CP	<b>H1095/5</b> STD 0.25 0.50	
TW/A	2	67.785/68.040	82.425/82.677		2.485		AL-LF	4356AF	<b>A191/2</b> STD	
SE/PB	1		28.939/28.972	21.700			BS	4369Y	<b>55-4159</b> SEMI	
										
 EE5242			HR397				<b>NA5070</b>  31.00x41.00x7.00mm, FPM <b>NF888</b>  93.00x172.00x12.00mm, FPM			

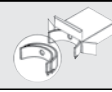
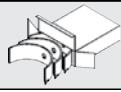
<b>945</b>	 <b>82.00</b>	<b>Diesel</b>					
<b>192 A1.000</b>	4 Cyl.	18.5:1	1910cc	<b>85kW (115)PS</b>	<b>Turbo Intercooled</b>	<b>TD16398</b>	<b>221</b>
<b>939 A1.000</b>	4 Cyl.		1910cc	<b>88kW (120)PS</b>	<b>Turbo Intercooled</b>	<b>TD18448</b>	<b>247</b>

			
<b>87-124000-30</b> <b>87-124008-30</b>  <b>A</b> 46.50 <b>B-</b> 17.45 <b>BØ</b> 37.55 <b>C</b> 0.65 <b>D</b> 72.50  26x61  <b>NB RT</b>	<b>STD</b> <b>0.60mm</b>    	<b>08-124000-00</b> STD <b>08-124006-00</b> 0.40mm <b>08-124008-00</b> 0.60mm 06/00 →  2.00  CK P 2.00  P 2.00  CR P	<b>14-021051-00 D</b> <b>B</b> 85.57 <b>C</b> 155.00 <b>D</b> 88.53 <b>E</b> 4.00 <b>14-028960-00 D</b> <b>B</b> 85.00 <b>C</b> 155.00 <b>D</b> 88.00 <b>E</b> 4.50  

									
BE/PL	1	50.787/50.805	53.901/53.913	19.500	1.534	0.030/0.080	EC	71-3994	<b>71-3994</b> STD 0.25 [22]
MB/HL 1-5	5	59.986/60.000	63.705/63.718	20.750	1.844	0.031/0.075	BS	4356CP	<b>H1095/5</b> STD 0.25 0.50
TW/A	2	67.785/68.040	82.425/82.677		2.485		AL-LF	4356AF	<b>A191/2</b> STD
SE/PB	1		28.939/28.972	21.700			BS	4369Y	<b>55-4159</b> SEMI

		
<b>EG7390</b>	<b>HR397</b>	<b>NA5070</b>  31.00x41.00x7.00mm, FPM <b>NF888</b>  93.00x172.00x12.00mm, FPM

# FIAT GROUP

<b>946</b>	<b>82.00</b>	<b>Diesel</b>					
192 A5.000	4 Cyl.	18.5:1	1910cc	<b>103kW (140)PS</b>	<b>Turbo Intercooled</b>	<b>TD17980</b>	<b>223</b>
192 A5.000 Euro 3 (D3)	4 Cyl.	18.5:1	1910cc	<b>103kW (140)PS</b>	<b>Turbo Intercooled</b>	<b>TD17981</b>	<b>224</b>
192 B1.000	4 Cyl.	18.5:1	1910cc	<b>100kW (136)PS</b>	<b>Turbo Intercooled</b>	<b>TD18944</b>	<b>223</b>
192 B1.000	4 Cyl.	18.5:1	1910cc	<b>100kW (136)PS</b>	<b>Turbo Intercooled</b>	<b>TD19061</b>	<b>224</b>
937 A4.000	4 Cyl.		1910cc	<b>93-103kW (126-140)PS</b>	<b>Turbocharged</b>	<b>TD18844</b>	<b>238</b>
937 A4.000	4 Cyl.		1910cc	<b>93kW (126)PS</b>	<b>Turbo Intercooled</b>	<b>TD18943</b>	<b>239</b>
937 A5.000	4 Cyl.		1910cc	<b>110kW (150)PS</b>	<b>Turbo Intercooled</b>	<b>TD18078</b>	<b>241</b>
937 A5.000	4 Cyl.	17.5:1	1910cc	<b>110kW (150)PS</b>	<b>Turbo Intercooled</b>	<b>TD18929</b>	<b>240</b>

<b>87-146100-00</b> STD <b>87-146108-00</b> 0.60mm  <b>A</b> 46.50 <b>B-</b> 15.40 <b>BØ</b> 41.50 <b>C</b> 1.03 <b>D</b> 72.50 26x61  <b>AK KK NB RT TP</b>	 <b>08-146100-00</b> STD <b>08-146106-00</b> 0.40mm <b>08-146108-00</b> 0.60mm  2.00  CK P 2.00  P 2.00  CK P  <b>08256-102</b>	<b>14-021051-00 D</b> <b>B</b> 85.57 <b>C</b> 155.00 <b>D</b> 88.53 <b>E</b> 4.00 <b>14-028960-00 D</b> <b>B</b> 85.00 <b>C</b> 155.00 <b>D</b> 88.00 <b>E</b> 4.50  	

BE/PL	1	50.787/50.805	53.901/53.913	19.500	1.534	0.030/0.080	EC	71-3994	<b>71-3994</b> STD 0.25 [22]
MB/HL	1	59.986/60.000	63.705/63.718	20.750	1.844	0.031/0.080	EC	72-3995	<b>72-3995</b> STD 0.25 0.50
TW/A	2	67.785/68.040	82.425/82.677		2.485		AL-LF	4356AF	<b>A191/2</b> STD
SE/PB	1		28.939/28.972	21.700			BS	4369Y	<b>55-4159</b> SEMI













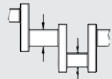



EE5181	HR397	<b>NA5070</b> 31.00x41.00x7.00mm, FPM <b>NF888</b> 93.00x172.00x12.00mm, FPM













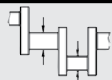
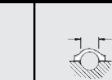



<b>947</b>	<b>82.00</b>	<b>Diesel</b>					
192 A8.000	4 Cyl.		1910cc	<b>88kW (120)PS</b>	<b>Turbo Intercooled</b>	<b>TD20238</b>	<b>225</b>











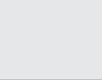

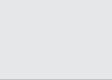

	<b>08-124000-00</b> STD <b>08-124006-00</b> 0.40mm <b>08-124008-00</b> 0.60mm  2.00  CK P 2.00  P 2.00  CR P		





...Continued

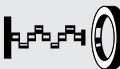





<b>947</b>		 <b>82.00</b>	<b>Diesel</b>								
											
BE/PL	1	50.787/50.805	53.901/53.913	19.500	1.534	0.030/0.080	EC	71-3994	<b>71-3994</b> STD 0.25	[22]	
MB/HL	1	59.986/60.000	63.705/63.718	20.750	1.844	0.031/0.080	EC	72-3995	<b>72-3995</b> STD 0.25 0.50		
TW/A	2	67.785/68.040	82.425/82.677		2.485		AL-LF	4356AF	<b>A191/2</b> STD		
SE/PB	1		28.939/28.972	21.700			BS	4369Y	<b>55-4159</b> SEMI		
											
EE5181			HR397			NA5070  31.00x41.00x7.00mm, FPM NF888  93.00x172.00x12.00mm, FPM					



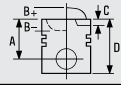







<b>948</b>		 <b>82.00</b>	<b>Diesel</b>								
<b>192 A9.000</b>	4 Cyl.	18.45:1	1910cc	<b>74kW (100)PS</b>	<b>Turbo Intercooled</b>	<b>TD18451</b>	<b>226</b>				
<b>192 B5.000</b>	4 Cyl.		1910cc	<b>66kW (90)PS</b>	<b>Turbo Intercooled</b>	<b>TD19308</b>	<b>228</b>				
<b>937 A3.000</b>	4 Cyl.		1910cc	<b>88kW (120)PS</b>	<b>Turbo Intercooled</b>	<b>TD20727</b>	<b>237</b>				
											
BE/PL	1	50.787/50.805	53.901/53.913	19.500	1.534	0.030/0.080	EC	71-3994	<b>71-3994</b> STD 0.25	[22]	
MB/HL	1	59.986/60.000	63.705/63.718	20.750	1.844	0.031/0.080	EC	72-3995	<b>72-3995</b> STD 0.25 0.50		
TW/A	2	67.785/68.040	82.425/82.677		2.485		AL-LF	4356AF	<b>A191/2</b> STD		
SE/PB	1		28.939/28.972	21.700			BS	4369Y	<b>55-4159</b> SEMI		
											
EE5181			HR397			NA5070  31.00x41.00x7.00mm, FPM NF888  93.00x172.00x12.00mm, FPM					





<b>949</b>		 <b>82.00</b>	<b>Diesel</b>								
<b>192 B4.000</b>	4 Cyl.	18:1	1910cc	<b>85kW (116)PS</b>	<b>Turbo Intercooled</b>	<b>TD24592</b>	<b>227</b>				
											
BE/PL	1	50.787/50.805	53.901/53.913	19.500	1.534	0.030/0.080	EC	71-3994	<b>71-3994</b> STD 0.25	[22]	
MB/HL	1	59.986/60.000	63.705/63.718	20.750	1.844	0.031/0.080	EC	72-3995	<b>72-3995</b> STD 0.25 0.50		
TW/A	2	67.785/68.040	82.425/82.677		2.485		AL-LF	4356AF	<b>A191/2</b> STD		
SE/PB	1		28.939/28.972	21.700			BS	4369Y	<b>55-4159</b> SEMI		
											
EE5181			HR397			NA5070  31.00x41.00x7.00mm, FPM NF888  93.00x172.00x12.00mm, FPM					



# FIAT GROUP











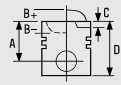

<b>950</b>	 <b>82.00</b>	<b>Diesel</b>					
<b>199 A5.000</b>	4 Cyl.	18:1	1910cc	<b>96kW (131)PS</b>	<b>Turbo Intercooled</b>	<b>TD20762</b>	<b>229</b>
<b>D19AA</b>	4 Cyl.	18:1	1910cc	<b>88kW (120)PS</b>	<b>Turbo Intercooled</b>	<b>TD20930</b>	<b>257</b>

			
	<b>08-124000-00</b> STD <b>08-124006-00</b> 0.40mm <b>08-124008-00</b> 0.60mm  2.00  CK P 2.00  P 2.00  CR P		

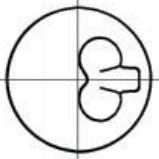





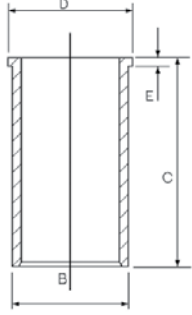





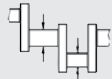
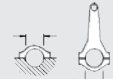

									
BE/PL	1	50.787/50.805	53.901/53.913	19.500	1.534	0.030/0.080	EC	71-3994	<b>71-3994</b> [22] STD 0.25
MB/HL 1-5	5	59.986/60.000	63.705/63.718	20.750	1.844	0.031/0.075	BS	4356CP	<b>H1095/5</b> STD 0.25 0.50
TW/A	2	67.785/68.040	82.425/82.677		2.485		AL-LF	4356AF	<b>A191/2</b> STD
SE/PB	1		28.939/28.972	21.700			BS	4369Y	<b>55-4159</b> SEMI

		
<b>EG7390</b>	<b>HR397</b>	<b>NA5070</b>  31.00x41.00x7.00mm, FPM <b>NF888</b>  93.00x172.00x12.00mm, FPM

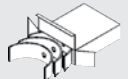







<b>951</b>	 <b>82.00</b>	<b>Diesel</b>				
<b>223 A6.000 Euro 3 (D3)</b>	4 Cyl.	22.6:1	1910cc	<b>46-48kW (63-65)PS</b>	<b>TD15829</b>	<b>230</b>

			
<b>87-124000-00</b> STD <b>87-124008-00</b> 0.60mm  A 44.45 B- 2.60 D 70.40  26x65 RT	    <b>08-124000-00</b> STD <b>08-124006-00</b> 0.40mm <b>08-124008-00</b> 0.60mm 06/00→  2.00  CK P 2.00  P 2.00  CR P  <b>08-107900-00</b> STD <b>08-107908-00</b> 0.60mm →06/00  2.50  CR P 2.00  P 2.00  CR P	<b>14-021051-00 D</b> B 85.57 C 155.00 D 88.53 E 4.00 <b>14-028960-00 D</b> B 85.00 C 155.00 D 88.00 E 4.50  	

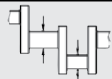
...Continued

<b>951</b>		 <b>82.00</b>	<b>Diesel</b>								
											
BE/PL	4	50.787/50.807	53.901/53.913	19.500	1.534	0.028/0.083	BS	4350CP	<b>71-4157/4</b> STD 0.25 0.50		
MB/HL 1,2,4,5	4	52.982/53.000	56.705/56.718	20.750	1.843	0.019/0.075	AL-LF	4351RA	<b>H1096/5</b> STD 0.25 0.50		
MB/HL 3	1	52.982/53.000	56.705/56.718	20.750	1.838	0.029/0.085	AL-LF	4352RA			
TW/A	2	58.808/59.062	73.486/73.740		2.485		AL-LF	4351AF	<b>A190/2</b> STD		
											
EE5181				HR397				NA5070  31.00x41.00x7.00mm, FPM NF888  93.00x172.00x12.00mm, FPM			



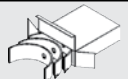

<b>952</b>		 <b>82.00</b>	<b>Diesel</b>							
<b>844 A1.000</b>	4 Cyl.	16.1:1	1910cc	<b>140kW (190)PS</b>	<b>Bi-Turbocharged Intercooled</b>				<b>TD21044</b>	<b>234</b>
<b>844 A1.000</b>	4 Cyl.	16.5:1	1910cc	<b>140kW (190)PS</b>	<b>Turbocharged</b>				<b>TD24649</b>	

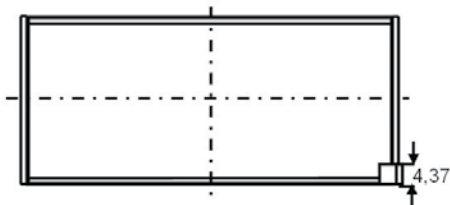
									
BE/PL	1	50.787/50.805	53.901/53.913	19.500	1.534	0.030/0.080	EC	71-3994	<b>71-3994</b> STD 0.25 [22]
BE/PL	1	50.787/50.805	53.901/53.913	19.500	1.534	0.030/0.080	EC-LF	71-4780	<b>71-4780</b> STD [23]

71-3994



MB/HL	1	59.986/60.000	63.705/63.718	20.750	1.844	0.031/0.080	EC	72-3995	<b>72-3995</b> STD 0.25 0.50
TW/A	2	67.785/68.040	82.425/82.677		2.485		AL-LF	4356AF	<b>A191/2</b> STD
SE/PB	1		28.939/28.972	21.700			BS	4369Y	<b>55-4159</b> SEMI

											
				HR397				NA5070  31.00x41.00x7.00mm, FPM NF888  93.00x172.00x12.00mm, FPM			

# FIAT GROUP

## 953

82.00

**Diesel**



937 A2.000      4 Cyl.      1910cc      85kW (116)PS      Turbo Intercooled      TD18313      235

<b>87-124000-30</b> <b>87-124008-30</b>  STD 0.60mm  A 46.50 B- 17.45 BØ 37.55 C 0.65 D 72.50 26x61  <b>NB RT</b>	  	<b>08-124000-00</b> STD <b>08-124006-00</b> 0.40mm <b>08-124008-00</b> 0.60mm  2.00  CK P 2.00  P 2.00  CR P	<b>14-021051-00 D</b> B 85.57 C 155.00 D 88.53 E 4.00 <b>14-028960-00 D</b> B 85.00 C 155.00 D 88.00 E 4.50  				

BE/PL	1	50.787/50.805	53.901/53.913	19.500	1.534	0.030/0.080	EC	71-3994	<b>71-3994</b> STD 0.25	[22]
MB/HL 1-5	5	59.986/60.000	63.705/63.718	20.750	1.844	0.031/0.075	BS	4356CP	<b>H1095/5</b> STD 0.25 0.50	
TW/A	2	67.785/68.040	82.425/82.677		2.485		AL-LF	4356AF	<b>A191/2</b> STD	
SE/PB	1		28.939/28.972	21.700			BS	4369Y	<b>55-4159</b> SEMI	

EE5181	HR397	<b>NA5070</b> 31.00x41.00x7.00mm, FPM <b>NF888</b> 93.00x172.00x12.00mm, FPM

## 954

82.00

**Diesel**











937 A2.000      4 Cyl.      18.45:1      1910cc      85kW (115)PS      Turbo Intercooled      TD16382      236

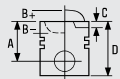
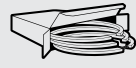



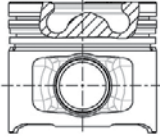

AR 37101      4 Cyl.      18.5:1      1910cc      81kW (110)PS      TD15510      256



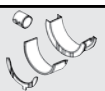

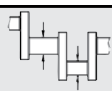
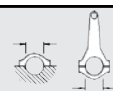
<b>87-107900-00</b> <b>87-107908-00</b>  STD 0.60mm  A 46.50 B- 17.50 BØ 37.50 C 0.80 D 72.50 26x65  <b>AK RT</b>	  	<b>08-107900-00</b> STD <b>08-107908-00</b> 0.60mm  2.50  CR P 2.00  P 2.00  CR P	<b>14-021051-00 D</b> B 85.57 C 155.00 D 88.53 E 4.00 <b>14-028960-00 D</b> B 85.00 C 155.00 D 88.00 E 4.50  				

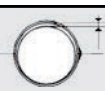

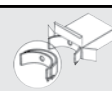
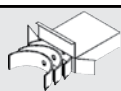
...Continued

**954**  **82.00** **Diesel**







							
<b>87-124000-30</b> <b>87-124008-30</b>  <b>A</b> 46.50 <b>B-</b> 17.45 <b>BØ</b> 37.55 <b>C</b> 0.65 <b>D</b> 72.50  26x61  <b>NB RT</b>	STD 0.60mm    	<b>08-124000-00</b> STD <b>08-124006-00</b> 0.40mm <b>08-124008-00</b> 0.60mm  2.00  CK P 2.00  P 2.00  CR P					

									
BE/PL	1	50.787/50.805	53.901/53.913	19.500	1.534	0.030/0.080	EC	71-3994	<b>71-3994</b> STD 0.25
MB/HL 1-5	5	59.986/60.000	63.705/63.718	20.750	1.844	0.031/0.075	BS	4356CP	<b>H1095/5</b> STD 0.25 0.50
TW/A	2	67.785/68.040	82.425/82.677		2.485		AL-LF	4356AF	<b>A191/2</b> STD
SE/PB	1		28.939/28.972	21.700			BS	4369Y	<b>55-4159</b> SEMI

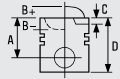
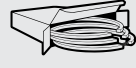
		
EE5181	HR397	<b>NA5070</b>  31.00x41.00x7.00mm, FPM <b>NF888</b>  93.00x172.00x12.00mm, FPM

**955**  **82.00** **Diesel** 



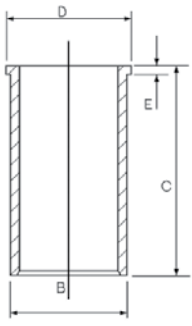





**937 A5.000** 4 Cyl. 18.5:1 1910cc **110kW (150)PS** **Turbo Intercooled** **TD21086**

							
		<b>08-124000-00</b> STD <b>08-124006-00</b> 0.40mm <b>08-124008-00</b> 0.60mm  2.00  CK P 2.00  P 2.00  CR P	<b>14-021051-00 D</b> <b>B</b> 85.57 <b>C</b> 155.00 <b>D</b> 88.53 <b>E</b> 4.00 <b>14-028960-00 D</b> <b>B</b> 85.00 <b>C</b> 155.00 <b>D</b> 88.00 <b>E</b> 4.50  				

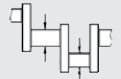
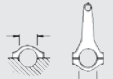
# FIAT GROUP

...Continued



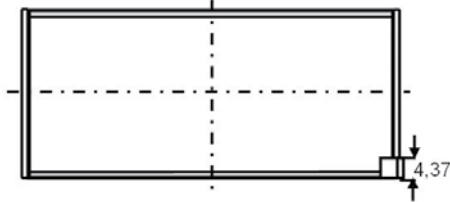

## 955 82.00 Diesel

										
BE/PL	1	50.787/50.805	53.901/53.913	19.500	1.534	0.030/0.080	EC	71-3994	<b>71-3994</b> STD 0.25	[22]
BE/PL	1	50.787/50.805	53.901/53.913	19.500	1.534	0.030/0.080	EC-LF	71-4780	<b>71-4780</b> STD	[23]

71-3994











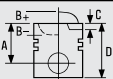

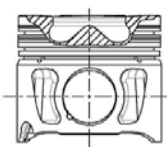
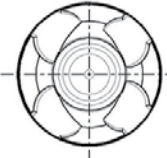

MB/HL	1	59.986/60.000	63.705/63.718	20.750	1.844	0.031/0.080	EC	72-3995	<b>72-3995</b> STD 0.25 0.50
TW/A	2	67.785/68.040	82.425/82.677		2.485		AL-LF	4356AF	<b>A191/2</b> STD
SE/PB	1		28.939/28.972	21.700			BS	4369Y	<b>55-4159</b> SEMI



		
EE5181	HR397	NA5070  31.00x41.00x7.00mm, FPM NF888  93.00x172.00x12.00mm, FPM



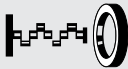



## 956 82.00 Diesel



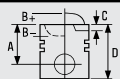
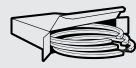



937 A6.000 4 Cyl. 17.5:1 1910cc 125kW (170)PS Turbo Intercooled TD24643 242



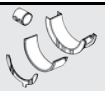

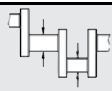
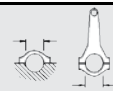
			
<b>87-146100-10</b> STD <b>87-146106-10</b> 0.40mm  A 46.50 B- 15.40 BØ 41.50 C 1.07 C 1.02 D 72.50  30x67  AK KK RT TP	   <b>08269-503</b>	<b>08-146100-00</b> STD <b>08-146106-00</b> 0.40mm <b>08-146108-00</b> 0.60mm  2.00  CK P 2.00  P 2.00  CK P	

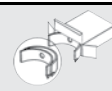
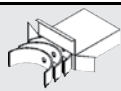

		
EE5181	HR397	NA5070  31.00x41.00x7.00mm, FPM NF888  93.00x172.00x12.00mm, FPM









**957**  **82.00 Diesel**   
**937 A7.000** 4 Cyl. 1910cc **85kW (115)PS** **Turbo Intercooled** **TD19307** **244**



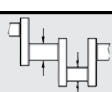
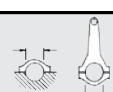

			
	<b>08-124000-00</b> STD <b>08-124006-00</b> 0.40mm <b>08-124008-00</b> 0.60mm  2.00  CK P 2.00  P 2.00  CR P		

									
BE/PL	1	50.787/50.805	53.901/53.913	19.500	1.534	0.030/0.080	EC	71-3994	<b>71-3994</b> [22] STD 0.25
TW/A	2	67.785/68.040	82.425/82.677		2.485		AL-LF	4356AF	<b>A191/2</b> STD
SE/PB	1		28.939/28.972	21.700			BS	4369Y	<b>55-4159</b> SEMI

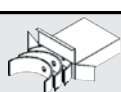





		
<b>EG7390</b>	<b>HR397</b>	<b>NA5070</b>  31.00x41.00x7.00mm, FPM <b>NF888</b>  93.00x172.00x12.00mm, FPM

**958**  **82.00 Diesel**   
**937 A7.000** 4 Cyl. 1910cc **85kW (115)PS** **Turbo Intercooled** **TD20933** **243**

									
BE/PL	1	50.787/50.805	53.901/53.913	19.500	1.534	0.030/0.080	EC	71-3994	<b>71-3994</b> [22] STD 0.25
TW/A	2	67.785/68.040	82.425/82.677		2.485		AL-LF	4356AF	<b>A191/2</b> STD
SE/PB	1		28.939/28.972	21.700			BS	4369Y	<b>55-4159</b> SEMI

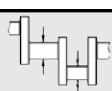
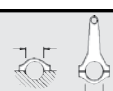
		
<b>EG7390</b>	<b>HR397</b>	<b>NA5070</b>  31.00x41.00x7.00mm, FPM <b>NF888</b>  93.00x172.00x12.00mm, FPM

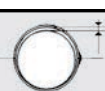

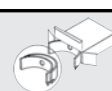
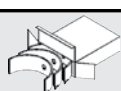



**959**  **82.00 Diesel**   
**937 A8.000** 4 Cyl. 1910cc **100-100kW (136-136)PS** **Turbo Intercooled** **TD20271** **245**

									
BE/PL	1	50.787/50.805	53.901/53.913	19.500	1.534	0.030/0.080	EC	71-3994	<b>71-3994</b> [22] STD 0.25
TW/A	2	67.785/68.040	82.425/82.677		2.485		AL-LF	4356AF	<b>A191/2</b> STD
SE/PB	1		28.939/28.972	21.700			BS	4369Y	<b>55-4159</b> SEMI

# FIAT GROUP

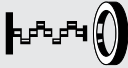







...Continued



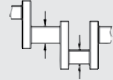
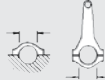



## 959 82.00 Diesel

		
 EG7450	HR397	<b>NA5070</b>  31.00x41.00x7.00mm, FPM <b>NF888</b>  93.00x172.00x12.00mm, FPM

## 960 82.00 Diesel

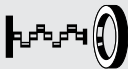





<b>939 A1.000</b>	4 Cyl.	1910cc	<b>88kW (120)PS</b>	<b>Turbo Intercooled</b>	<b>TD18915</b>	<b>246</b>
<b>939 A7.000</b>	4 Cyl.	1910cc	<b>85kW (115)PS</b>	<b>Turbo Intercooled</b>	<b>TD18916</b>	<b>250</b>
<b>939 A7.000</b>	4 Cyl.	1910cc	<b>85kW (115)PS</b>	<b>Turbo Intercooled</b>	<b>TD20263</b>	<b>227</b>



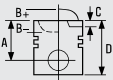
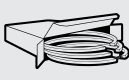





									
BE/PL	1	50.787/50.805	53.901/53.913	19.500	1.534	0.030/0.080	EC	71-3994	<b>71-3994</b> [22] STD 0.25
MB/HL 1-5	5	59.986/60.000	63.705/63.718	20.750	1.844	0.031/0.075	BS	4356CP	<b>H1095/5</b> STD 0.25 0.50
TW/A	2	67.785/68.040	82.425/82.677		2.485		AL-LF	4356AF	<b>A191/2</b> STD
SE/PB	1		28.939/28.972	21.700			BS	4369Y	<b>55-4159</b> SEMI



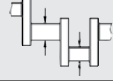
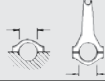



		
 EG7390	HR397	<b>NA5070</b>  31.00x41.00x7.00mm, FPM <b>NF888</b>  93.00x172.00x12.00mm, FPM

## 961 82.00 Diesel



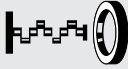







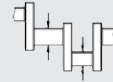

<b>939 A2.000</b>	4 Cyl.	17.5:1	1910cc	<b>110kW (150)PS</b>	<b>Turbo Intercooled</b>	<b>TD18449</b>	<b>249</b>
<b>939 A2.000</b>	4 Cyl.	17.5:1	1910cc	<b>110kW (150)PS</b>	<b>Turbo Intercooled</b>	<b>TD18473</b>	<b>248</b>







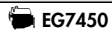

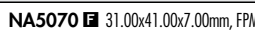
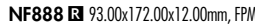

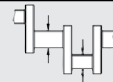

			
	<b>08-146100-00</b> STD <b>08-146106-00</b> 0.40mm <b>08-146108-00</b> 0.60mm  2.00  CK P 2.00  P 2.00  CK P		









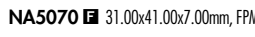
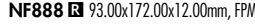







									
BE/PL	1	50.787/50.805	53.901/53.913	19.500	1.534	0.030/0.080	EC	71-3994	<b>71-3994</b> [22] STD 0.25
MB/HL	1	59.986/60.000	63.705/63.718	20.750	1.844	0.031/0.080	EC	72-3995	<b>72-3995</b> STD 0.25 0.50
TW/A	2	67.785/68.040	82.425/82.677		2.485		AL-LF	4356AF	<b>A191/2</b> STD
SE/PB	1		28.939/28.972	21.700			BS	4369Y	<b>55-4159</b> SEMI

		
 EG7450	HR397	<b>NA5070</b>  31.00x41.00x7.00mm, FPM <b>NF888</b>  93.00x172.00x12.00mm, FPM



<b>962</b>		 <b>82.00</b>	<b>Diesel</b>							
<b>939 A8.000</b>		4 Cyl.	18.4:1	1910cc	<b>100kW (136)PS</b>		<b>Turbo Intercooled</b>		<b>TD25733</b>	<b>252</b>
										
BE/PL	1	50.787/50.805	53.901/53.913	19.500	1.534	0.030/0.080	EC	71-3994	<b>71-3994</b> STD 0.25	[22]
MB/HL 1-5	5	59.986/60.000	63.705/63.718	20.750	1.844	0.031/0.075	BS	4356CP	<b>H1095/5</b> STD 0.25 0.50	
TW/A	2	67.785/68.040	82.425/82.677		2.485		AL-LF	4356AF	<b>A191/2</b> STD	
SE/PB	1		28.939/28.972	21.700			BS	4369Y	<b>55-4159</b> SEMI	
						 NA5070 31.00x41.00x7.00mm, FPM				
						 NF888 93.00x172.00x12.00mm, FPM				









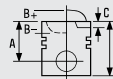

<b>963</b>		 <b>82.00</b>	<b>Diesel</b>							
<b>939 A8.000</b>		4 Cyl.	18.4:1	1910cc	<b>100kW (136)PS</b>		<b>Turbo Intercooled</b>		<b>TD18925</b>	<b>251</b>
										
BE/PL	1	50.787/50.805	53.901/53.913	19.500	1.534	0.030/0.080	EC	71-3994	<b>71-3994</b> STD 0.25	[22]
MB/HL	1	59.986/60.000	63.705/63.718	20.750	1.844	0.031/0.080	EC	72-3995	<b>72-3995</b> STD 0.25 0.50	
TW/A	2	67.785/68.040	82.425/82.677		2.485		AL-LF	4356AF	<b>A191/2</b> STD	
SE/PB	1		28.939/28.972	21.700			BS	4369Y	<b>55-4159</b> SEMI	
						 NA5070 31.00x41.00x7.00mm, FPM				
						 NF888 93.00x172.00x12.00mm, FPM				

<b>964</b>		 <b>82.00</b>	<b>Diesel</b>							
<b>AR 37101</b>		4 Cyl.	18.5:1	1910cc	<b>80-85kW (109-116)PS</b>		<b>Turbo Intercooled</b>		<b>TD17890</b>	<b>255</b>
										
<b>87-107900-00</b>	STD	<b>14-021051-00 D</b>	<b>08-107900-00</b>	STD	<b>14-021051-00 D</b>	<b>14-028960-00 D</b>	<b>14-021051-00 D</b>	<b>14-021051-00 D</b>	<b>14-021051-00 D</b>	<b>14-021051-00 D</b>
<b>87-107908-00</b>	0.60mm	<b>B 85.57 C 155.00 D 88.53 E 4.00</b>	<b>08-107908-00</b>	0.60mm	<b>B 85.00 C 155.00 D 88.00 E 4.50</b>					
			→06/00							
<b>A</b> 46.50			<b>2.50</b>		<b>CR P</b>					
<b>B-</b> 17.50			<b>2.00</b>		<b>P</b>					
<b>BØ</b> 37.50			<b>2.00</b>		<b>CR P</b>					
<b>C</b> 0.80										
<b>D</b> 72.50										
 <b>26x65</b>										
<b>AK RT</b>										

# FIAT GROUP

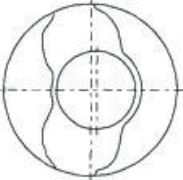
...Continued

## 964 82.00 Diesel











							
<b>87-124000-10</b> [13] <b>87-124008-10</b>  STD 0.60mm  A 46.50 B- 17.50 BØ 37.50 C 0.55 D 72.50  26x65  <b>AK RT</b>	  	<b>08-124000-00</b> STD <b>08-124006-00</b> 0.40mm <b>08-124008-00</b> 0.60mm 06/00 →  2.00  CK P 2.00  P 2.00  CR P					

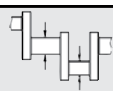



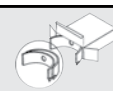
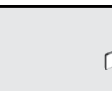
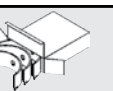

[13] Piston Chamber Volume [ccm] 19.91

[13] Volume de la cavité du piston [cm³] 19.91

[13] Volume camera pistone [cm³] 19.91









[13] Volumen de cavidad del pistón [cc] 19.91

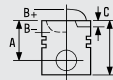



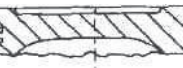
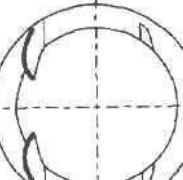



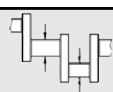

												
BE/PL	1	50.787/50.805	53.901/53.913	19.500	1.534	0.030/0.080	EC	71-3994	71-3994 STD 0.25	[22]		
MB/HL 1-5	5	59.986/60.000	63.705/63.718	20.750	1.844	0.031/0.075	BS	4356CP	H1095/5 STD 0.25 0.50			
TW/A	2	67.785/68.040	82.425/82.677		2.485		AL-LF	4356AF	A191/2 STD			
SE/PB	1		28.939/28.972	21.700			BS	4369Y	55-4159 SEMI			

			
EE5181	HR397	NA5070  31.00x41.00x7.00mm, FPM	NF888  93.00x172.00x12.00mm, FPM





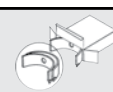
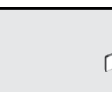
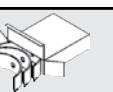

## 965 82.00 Petrol



175 A3.000	5 Cyl.	8.5:1	1998cc	162kW (220)PS	Turbo Intercooled	TD5491	259
175 A3.000	5 Cyl.	8.5:1	1998cc	162kW (220)PS	Turbocharged	TD11550	258







							
<b>87-529300-00</b> <b>87-529306-00</b>  STD 0.40mm  A 32.90 C 2.80 D 56.90  22x54	  	<b>08-529300-00</b> STD <b>08-529306-00</b> 0.40mm  1.20  NT 1.50  P 3.00  P					



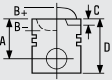
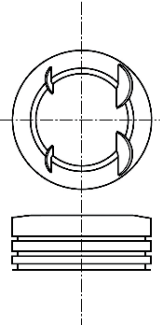
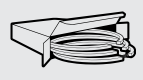
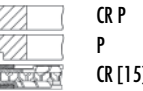





												
BE/PL	5	48.226/48.244	51.354/51.366	19.100	1.543	0.020/0.080	BS	4355CP	71-4209/5 STD 0.25 0.50			
MB/HL 1-6	6	59.986/60.000	63.705/63.718	20.750	1.844	0.031/0.075	BS	4356CP	H1095/6 STD 0.25 0.50			
TW/A	2	67.785/68.040	82.425/82.677		2.485		AL-LF	4356AF	A191/2 STD			
SE/PB	1	19.993/20.000	22.939/22.972	21.700			BS	4359Y	55-4540 SEMI			



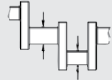
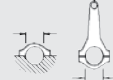

...Continued

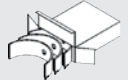

<b>965</b>	 <b>82.00</b>	<b>Petrol</b>
		
	<b>HR397</b>	<b>NA5070</b>  31.00x41.00x7.00mm, FPM <b>NF888</b>  93.00x172.00x12.00mm, FPM







<b>966</b>	 <b>82.00</b>	<b>Petrol</b>				
<b>182 A1.000</b>	5 Cyl.	10:1	1998cc	<b>108kW (147)PS</b>	<b>TD4397</b>	<b>260</b>
<b>182 B7.000</b>	5 Cyl.	10.7:1	1998cc	<b>113kW (154)PS</b>	<b>TD14389</b>	<b>263</b>
<b>838 A1.000</b>	5 Cyl.	10:1	1998cc	<b>107kW (146)PS</b>	<b>TD4616</b>	<b>266</b>

					
<b>87-787000-00</b> STD <b>87-787006-00</b> 0.40mm		<b>08-787000-00</b> STD <b>08-787006-00</b> 0.40mm	1.50  CR P 1.50  P 3.00  CR [15]		
<b>A</b> 32.90 <b>B+</b> 0.80 <b>D</b> 57.70  20x52					
[15] Steel	[15] Acier	[15] Acciaio	[15] Acero		

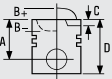
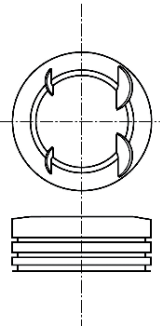
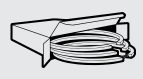
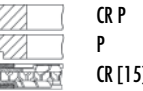
									
BE/PL	5	48.226/48.244	51.354/51.366	19.100	1.543	0.020/0.080	BS	4355CP	<b>71-4209/5</b> STD 0.25 0.50
MB/HL 1-6	6	59.986/60.000	63.705/63.718	20.750	1.844	0.031/0.075	BS	4356CP	<b>H1095/6</b> STD 0.25 0.50
TW/A	2	67.785/68.040	82.425/82.677		2.485		AL-LF	4356AF	<b>A191/2</b> STD
SE/PB	1	19.993/20.000	22.939/22.972	21.700			BS	4359Y	<b>55-4540</b> SEMI













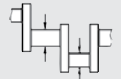

		
	<b>HR397</b>	<b>NA5070</b>  31.00x41.00x7.00mm, FPM <b>NF888</b>  93.00x172.00x12.00mm, FPM

<b>967</b>	 <b>82.00</b>	<b>Petrol</b>				
<b>182 B3.000</b>	5 Cyl.	10:1	1998cc	<b>113kW (154)PS</b>	<b>TD11789</b>	<b>261</b>







					
<b>87-787000-00</b> STD <b>87-787006-00</b> 0.40mm		<b>08-787000-00</b> STD <b>08-787006-00</b> 0.40mm	1.50  CR P 1.50  P 3.00  CR [15]		
<b>A</b> 32.90 <b>B+</b> 0.80 <b>D</b> 57.70  20x52					
[15] Steel	[15] Acier	[15] Acciaio	[15] Acero		



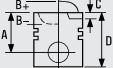
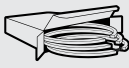

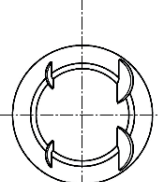







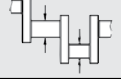

# FIAT GROUP





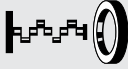

...Continued



<b>967</b>		 <b>82.00</b>	<b>Petrol</b>							
										
BE/PL	5	48.226/48.244	51.354/51.366	19.100	1.543	0.020/0.080	BS	4355CP	<b>71-4209/5</b> STD 0.25 0.50	
MB/HL 1-6	6	59.986/60.000	63.705/63.718	20.750	1.844	0.031/0.075	BS	4356CP	<b>H1095/6</b> STD 0.25 0.50	
TW/A	2	67.785/68.040	82.425/82.677		2.485		AL-LF	4356AF	<b>A191/2</b> STD	
SE/PB	1	19.993/20.000	22.939/22.972	21.700			BS	4359Y	<b>55-4540</b> SEMI	
										
ED5960			HR397				NA5070  31.00x41.00x7.00mm, FPM NF888  93.00x172.00x12.00mm, FPM			









<b>968</b>		 <b>82.00</b>	<b>Petrol</b>						
<b>182 B7.000</b>	5 Cyl.	10.7:1	1998cc	<b>113kW (154)PS</b>			<b>TD15498</b>	<b>262</b>	
<b>838 A6.000</b>	5 Cyl.	10.4:1	1998cc	<b>114kW (155)PS</b>			<b>TD5436</b>	<b>267</b>	

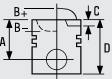
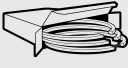



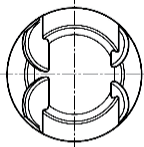



			
<b>87-787000-00</b> <b>87-787006-00</b>	STD 0.40mm		<b>08-787000-00</b> STD <b>08-787006-00</b> 0.40mm
A 32.90 B+ 0.80 D 57.70  20x52			1.50  CR P 1.50  P 3.00  CR [15]
[15] Steel	[15] Acier	[15] Acciaio	[15] Acero



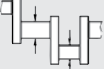
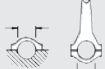

<b>967</b>		 <b>82.00</b>	<b>Petrol</b>							
										
BE/PL	5	48.226/48.244	51.354/51.366	19.100	1.543	0.020/0.080	BS	4355CP	<b>71-4209/5</b> STD 0.25 0.50	
MB/HL 1-6	6	59.986/60.000	63.705/63.718	20.750	1.844	0.031/0.075	BS	4356CP	<b>H1095/6</b> STD 0.25 0.50	
TW/A	2	67.785/68.040	82.425/82.677		2.485		AL-LF	4356AF	<b>A191/2</b> STD	
SE/PB	1	19.993/20.000	22.939/22.972	21.700			BS	4359Y	<b>55-4540</b> SEMI	
										
EW320			HR397				NA5070  31.00x41.00x7.00mm, FPM NF888  93.00x172.00x12.00mm, FPM			



<b>969</b>	 <b>82.00</b>	<b>Petrol</b>				
<b>185 A4.011</b>	5 Cyl.	8.5:1	1998cc	<b>134kW (182)PS</b>	<b>Turbocharged</b>	<b>TD24639</b>
						
	<b>HR397</b>	<b>NA5070</b>  31.00x41.00x7.00mm, FPM <b>NF888</b>  93.00x172.00x12.00mm, FPM				











<b>970</b>	 <b>82.00</b>	<b>Petrol</b>				
<b>185 A8.000</b>	5 Cyl.	10.5:1	1998cc	<b>110kW (150)PS</b>	<b>TD15630</b>	<b>264</b>
<b>185 A8.000 Euro 3 (D3)</b>	5 Cyl.	10.5:1	1998cc	<b>110kW (150)PS</b>	<b>TD15830</b>	<b>265</b>

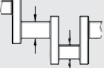



			
<b>87-118000-30</b> STD <b>87-118006-30</b> 0.40mm	<b>08-118000-00</b> STD <b>08-118006-00</b> 0.40mm <b>08-118008-00</b> 0.60mm		
<b>A</b> 31.90 <b>B+</b> 1.10 <b>D</b> 55.00  20x52	 	<b>1.19</b>  NT <b>1.20</b>  P <b>2.00</b>  P	

									
BE/PL	5	48.226/48.244	51.354/51.366	19.100	1.543	0.020/0.080	BS	4355CP	<b>71-4209/5</b> STD 0.25 0.50
MB/HL 1-6	6	59.986/60.000	63.705/63.718	20.750	1.844	0.031/0.075	BS	4356CP	<b>H1095/6</b> STD 0.25 0.50
TW/A	2	67.785/68.040	82.425/82.677		2.485		AL-LF	4356AF	<b>A191/2</b> STD
SE/PB	1	19.993/20.000	22.939/22.972	21.700			BS	4359Y	<b>55-4540</b> SEMI

		
<b>ED5960</b>	<b>HR397</b>	<b>NA5070</b>  31.00x41.00x7.00mm, FPM <b>NF888</b>  93.00x172.00x12.00mm, FPM

<b>971</b>	 <b>82.00</b>	<b>Petrol</b>					
<b>841 E.000</b>	5 Cyl.	8.5:1	1998cc	<b>136kW (185)PS</b>	<b>Turbo Intercooled</b>	<b>TD16731</b>	<b>268</b>

									
BE/PL	5	48.226/48.244	51.354/51.366	19.100	1.543	0.020/0.080	BS	4355CP	<b>71-4209/5</b> STD 0.25 0.50
MB/HL 1-6	6	59.986/60.000	63.705/63.718	20.750	1.844	0.031/0.075	BS	4356CP	<b>H1095/6</b> STD 0.25 0.50
TW/A	2	67.785/68.040	82.425/82.677		2.485		AL-LF	4356AF	<b>A191/2</b> STD
SE/PB	1	19.993/20.000	22.939/22.972	21.700			BS	4359Y	<b>55-4540</b> SEMI

		
<b>ED5960</b>	<b>HR397</b>	<b>NA5070</b>  31.00x41.00x7.00mm, FPM <b>NF888</b>  93.00x172.00x12.00mm, FPM

**972**

**82.00**

**Diesel**



185 A2.000    5 Cyl.    20.7:1    2387cc    91kW (125)PS    Turbo Intercooled    TD4406    269

<p><b>87-523100-00</b>    STD</p> <p><b>87-523108-00</b>    0.60mm</p> <p><b>A</b>    45.20</p> <p><b>B-</b>    2.15</p> <p><b>D</b>    71.15</p> <p> 26x65</p> <p><b>AK RT</b></p>	<p><b>08-523100-00</b>    STD</p> <p><b>08-523108-00</b>    0.60mm</p> <p>3.00        CK P</p> <p>2.00        P</p> <p>3.00        CR P</p>	<p><b>14-021051-00 D</b></p> <p><b>B</b> 85.57    <b>C</b> 155.00    <b>D</b> 88.53    <b>E</b> 4.00</p> <p><b>14-028960-00 D</b></p> <p><b>B</b> 85.00    <b>C</b> 155.00    <b>D</b> 88.00    <b>E</b> 4.50</p> 	



BE/PL	5	50.787/50.805	53.901/53.913	19.500	1.534	0.030/0.080	EC	71-3958	<b>71-3958/5</b> .010	
BE/PL	1	50.787/50.805	53.901/53.913	19.500	1.534	0.030/0.080	EC	71-3994	<b>71-3994</b> STD 0.25	[22]

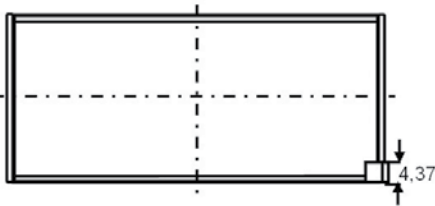







**71-3994**

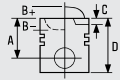
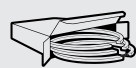



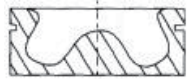
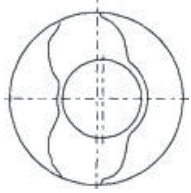



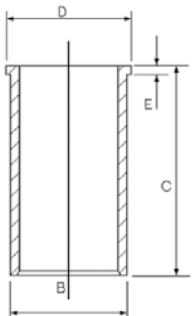

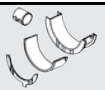
MB/HL 1-6	6	59.986/60.000	63.705/63.718	20.750	1.844	0.031/0.075	BS	4356CP	<b>H1095/6</b> STD 0.25 0.50
TW/A	2	67.785/68.040	82.425/82.677		2.485		AL-LF	4356AF	<b>A191/2</b> STD
SE/PB	1		28.939/28.972	21.700			BS	4369Y	<b>55-4159</b> SEMI

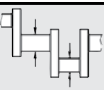
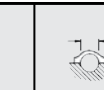
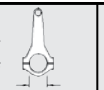
	<b>HR397</b>	<p><b>NA5070</b>  31.00x41.00x7.00mm, FPM</p> <p><b>NF888</b>  93.00x172.00x12.00mm, FPM</p>

<b>973</b>	 <b>82.00</b>	<b>Diesel</b>					
<b>185 A6.000</b>	5 Cyl.	18.45:1	2387cc	<b>96kW (130)PS</b>	<b>Turbo Intercooled</b>	<b>TD18145</b>	<b>270</b>
<b>839 A5.000</b>	5 Cyl.	18.5:1	2387cc	<b>96-99kW (131-135)PS</b>	<b>Turbo Intercooled</b>	<b>TD14408</b>	<b>273</b>
<b>839 A5.000</b>	5 Cyl.	18.5:1	2387cc	<b>96-99kW (131-135)PS</b>	<b>Turbo Intercooled</b>	<b>TD17399</b>	<b>273</b>
<b>AR 32501</b>	5 Cyl.		2387cc	<b>99-100kW (135-136)PS</b>	<b>Turbo Intercooled</b>	<b>TD9770</b>	<b>289</b>
<b>AR 34202</b>	5 Cyl.	18.45:1	2387cc	<b>100kW (136)PS</b>	<b>Turbo Intercooled</b>	<b>TD11604</b>	<b>290</b>

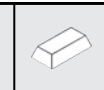

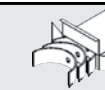

			
<b>87-108000-00</b> <b>87-108008-00</b> STD 0.60mm  <b>A</b> 47.25 <b>B-</b> 17.50 <b>BØ</b> 37.45 <b>D</b> 73.25  26x61  <b>AK NB RT</b>	  	<b>08-108000-00</b> STD <b>08-108008-00</b> 0.60mm  3.00  CK P 2.00  P 3.00  CR P	<b>14-021051-00 D</b> <b>B</b> 85.57 <b>C</b> 155.00 <b>D</b> 88.53 <b>E</b> 4.00 <b>14-028960-00 D</b> <b>B</b> 85.00 <b>C</b> 155.00 <b>D</b> 88.00 <b>E</b> 4.50 

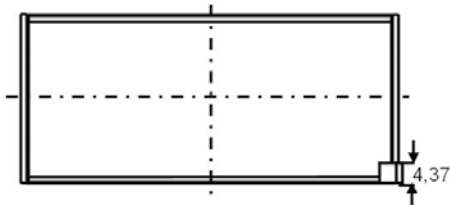

											
BE/PL	5	50.787/50.805	53.901/53.913	19.500	1.534	0.030/0.080	EC	71-3958	71-3958/5 .010		
BE/PL	1	50.787/50.805	53.901/53.913	19.500	1.534	0.030/0.080	EC	71-3994	71-3994 STD 0.25	[22]	







71-3994



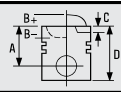
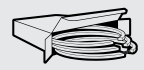





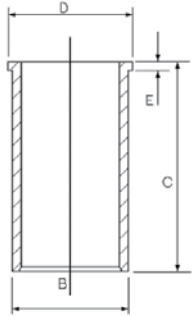

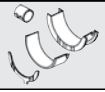

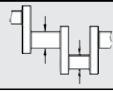



MB/HL 1-6	6	59.986/60.000	63.705/63.718	20.750	1.844	0.031/0.075	BS	4356CP	H1095/6 STD 0.25 0.50
TW/A	2	67.785/68.040	82.425/82.677		2.485		AL-LF	4356AF	A191/2 STD
SE/PB	1		28.939/28.972	21.700			BS	4369Y	55-4159 SEMI

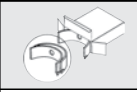
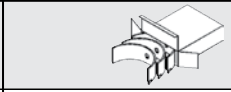

		
	HR397	<b>NA5070</b>  31.00x41.00x7.00mm, FPM <b>NF888</b>  93.00x172.00x12.00mm, FPM







<b>974</b>	 <b>82.00</b>	<b>Diesel</b>					
<b>838 A3.000</b>	5 Cyl.	21:1	2387cc	<b>91kW (124)PS</b>	<b>Turbo Intercooled</b>	<b>TD4618</b>	<b>271</b>
<b>838 A7.000</b>	5 Cyl.	21:1	2387cc	<b>91kW (124)PS</b>	<b>Turbo Intercooled</b>	<b>TD5437</b>	<b>271</b>

			
<b>87-523100-00</b> <b>87-523108-00</b> STD 0.60mm  <b>A</b> 45.20 <b>B-</b> 2.15 <b>D</b> 71.15  26x65  <b>AK RT</b>	<b>08-523100-00</b> STD <b>08-523108-00</b> 0.60mm  3.00  CK P 2.00  P 3.00  CR P	<b>14-021051-00 D</b> <b>B</b> 85.57 <b>C</b> 155.00 <b>D</b> 88.53 <b>E</b> 4.00 <b>14-028960-00 D</b> <b>B</b> 85.00 <b>C</b> 155.00 <b>D</b> 88.00 <b>E</b> 4.50 	

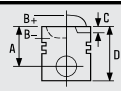
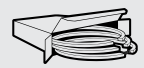
									
BE/PL	1	50.787/50.805	53.901/53.913	19.500	1.534	0.030/0.080	EC	71-3994	<b>71-3994</b> STD 0.25
MB/HL 1-6	6	59.986/60.000	63.705/63.718	20.750	1.844	0.031/0.075	BS	4356CP	<b>H1095/6</b> STD 0.25 0.50
TW/A	2	67.785/68.040	82.425/82.677		2.485		AL-LF	4356AF	<b>A191/2</b> STD
SE/PB	1		28.939/28.972	21.700			BS	4369Y	<b>55-4159</b> SEMI

		
<b>HR397</b>	<b>NA5070</b>  31.00x41.00x7.00mm, FPM	<b>NF888</b>  93.00x172.00x12.00mm, FPM

<b>975</b>	 <b>82.00</b>	<b>Diesel</b>					
<b>838 A8.000</b>	5 Cyl.	18.45:1	2387cc	<b>100kW (136)PS</b>	<b>Turbocharged</b>	<b>TD11551</b>	<b>272</b>
<b>AR 32501</b>	5 Cyl.	18.5:1	2387cc	<b>99-100kW (135-136)PS</b>	<b>Turbo Intercooled</b>	<b>TD17400</b>	<b>273</b>

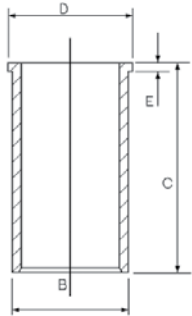
			
<b>87-108000-00</b> <b>87-108008-00</b> STD 0.60mm  <b>A</b> 47.25 <b>B-</b> 17.50 <b>BØ</b> 37.45 <b>D</b> 73.25  26x61  <b>AK NB RT</b>	<b>08-108000-00</b> STD <b>08-108008-00</b> 0.60mm  3.00  CK P 2.00  P 3.00  CR P	<b>14-021051-00 D</b> <b>B</b> 85.57 <b>C</b> 155.00 <b>D</b> 88.53 <b>E</b> 4.00 <b>14-028960-00 D</b> <b>B</b> 85.00 <b>C</b> 155.00 <b>D</b> 88.00 <b>E</b> 4.50 	









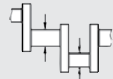
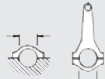

...Continued

975		82.00	Diesel							
BE/PL	1	50.787/50.805	53.901/53.913	19.500	1.534	0.030/0.080	EC	71-3994	71-3994 STD 0.25	[22]
MB/HL 1-6	6	59.986/60.000	63.705/63.718	20.750	1.844	0.031/0.075	BS	4356CP	H1095/6 STD 0.25 0.50	
TW/A	2	67.785/68.040	82.425/82.677		2.485		AL-LF	4356AF	A191/2 STD	
SE/PB	1		28.939/28.972	21.700			BS	4369Y	55-4159 SEMI	
		HR397			NA5070  31.00x41.00x7.00mm, FPM			NF888  93.00x172.00x12.00mm, FPM		

976		82.00	Diesel							
839 A6.000 Euro 3 (D3)		5 Cyl.	18.45:1	2387cc	103kW (140)PS		Turbo Intercooled		TD18819	274
841 C000		5 Cyl.	18.5:1	2387cc	110kW (150)PS		Turbo Intercooled		TD16383	277
87-107900-00	STD		08-107900-00	STD	14-021051-00 D					
87-107908-00	0.60mm		08-107908-00	0.60mm	B 85.57 C 155.00 D 88.53 E 4.00					
A 46.50			2.50		CR P					
B- 17.50			2.00		P					
BØ 37.50			2.00		CR P					
C 0.80										
D 72.50										
	26x65									
AK RT										
87-124000-30	STD		08-124000-00	STD	14-028960-00 D					
87-124008-30	0.60mm		08-124006-00	0.40mm	B 85.00 C 155.00 D 88.00 E 4.50					
A 46.50			2.00		CK P					
B- 17.45			2.00		P					
BØ 37.55			2.00		CR P					
C 0.65										
D 72.50										
	26x61									
NB RT										



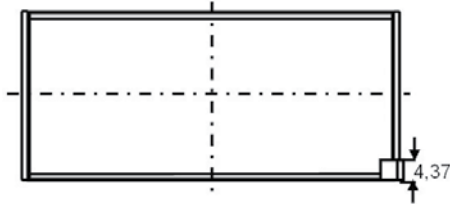

**976**  **82.00 Diesel**

									
BE/PL	5	50.787/50.805	53.901/53.913	19.500	1.534	0.030/0.080	EC	71-3958	<b>71-3958/5</b> STD 0.10
BE/PL	1	50.787/50.805	53.901/53.913	19.500	1.534	0.030/0.080	EC	71-3994	<b>71-3994</b> STD 0.25 [22]

71-3994











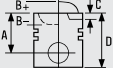
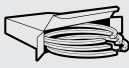

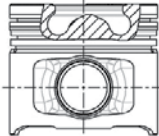





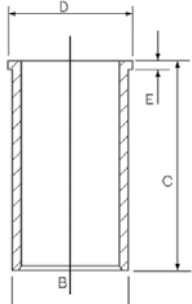

MB/HL 1-6	6	59.986/60.000	63.705/63.718	20.750	1.844	0.031/0.075	BS	4356CP	<b>H1095/6</b> STD 0.25 0.50
TW/A	2	67.785/68.040	82.425/82.677		2.485		AL-LF	4356AF	<b>A191/2</b> STD
SE/PB	1		28.939/28.972	21.700			BS	4369Y	<b>55-4159</b> SEMI

		
EA5780	HR397	NA5070  31.00x41.00x7.00mm, FPM NF888  93.00x172.00x12.00mm, FPM

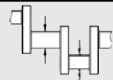
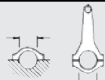
**977**  **82.00 Diesel** 







<b>839 A6.000 Euro 3 (D3)</b>	5 Cyl.	18.45:1	2387cc	<b>103kW (140)PS</b>	<b>Turbo Intercooled</b>	<b>TD15631</b>	<b>275</b>
<b>841 C.000</b>	5 Cyl.	18.5:1	2387cc	<b>110kW (150)PS</b>	<b>Turbo Intercooled</b>	<b>TD16472</b>	<b>276</b>

			
<b>87-124000-30</b> <b>87-124008-30</b>	STD 0.60mm	 	<b>08-124000-00</b> STD <b>08-124006-00</b> 0.40mm <b>08-124008-00</b> 0.60mm
A 46.50 B- 17.45 BØ 37.55 C 0.65 D 72.50  26x61		2.00  CK P 2.00  P 2.00  CR P	<b>14-021051-00 D</b> B 85.57 C 155.00 D 88.53 E 4.00 <b>14-028960-00 D</b> B 85.00 C 155.00 D 88.00 E 4.50
<b>NB RT</b>			

									
BE/PL	1	50.787/50.805	53.901/53.913	19.500	1.534	0.030/0.080	EC	71-3994	<b>71-3994</b> STD 0.25 [22]
MB/HL 1-6	6	59.986/60.000	63.705/63.718	20.750	1.844	0.031/0.075	BS	4356CP	<b>H1095/6</b> STD 0.25 0.50
TW/A	2	67.785/68.040	82.425/82.677		2.485		AL-LF	4356AF	<b>A191/2</b> STD
SE/PB	1		28.939/28.972	21.700			BS	4369Y	<b>55-4159</b> SEMI









...Continued

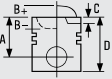
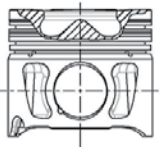



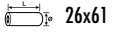

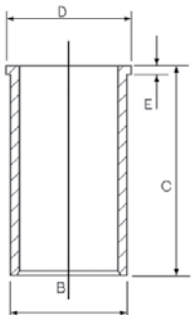

**977**  **82.00 Diesel**



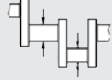
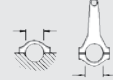



		
 EA5780	HR397	NA5070  31.00x41.00x7.00mm, FPM NF888  93.00x172.00x12.00mm, FPM

**978**  **82.00 Diesel** 

<b>841 G.000</b>	5 Cyl.	2387cc	<b>129kW (175)PS</b>	<b>Turbo Intercooled</b>	<b>TD18292</b>	<b>278</b>	
<b>841 M.000</b>	5 Cyl.	18:1	2387cc	<b>120-147kW (163-200)PS</b>	<b>Turbo Intercooled</b>	<b>TD20934</b>	<b>282</b>

					
<b>87-146100-00</b> STD <b>87-146108-00</b> 0.60mm			<b>08-146100-00</b> STD <b>08-146106-00</b> 0.40mm <b>08-146108-00</b> 0.60mm	<b>14-021051-00 D</b> <b>B 85.57 C 155.00 D 88.53 E 4.00</b> <b>14-028960-00 D</b> <b>B 85.00 C 155.00 D 88.00 E 4.50</b>	
A 46.50 B- 15.40 BØ 41.50 C 1.03 D 72.50  26x61			2.00  CK P 2.00  P 2.00  CK P		
<b>AK KK NB RT TP</b>		<b>08256-102</b>			

									
BE/PL	1	50.787/50.805	53.901/53.913	19.500	1.534	0.030/0.080	EC	71-3994	<b>71-3994</b> [22] STD 0.25
MB/HL	1	59.986/60.000	63.705/63.718	20.750	1.844	0.031/0.080	EC	72-3995	<b>72-3995</b> STD 0.25 0.50
TW/A	2	67.785/68.040	82.425/82.677		2.485		AL-LF	4356AF	<b>A191/2</b> STD
SE/PB	1		28.939/28.972	21.700			BS	4369Y	<b>55-4159</b> SEMI

		
 ED5910	HR397	NA5070  31.00x41.00x7.00mm, FPM NF888  93.00x172.00x12.00mm, FPM

# FIAT GROUP









**979**

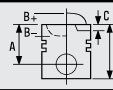
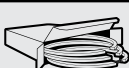



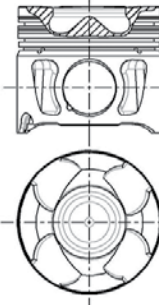

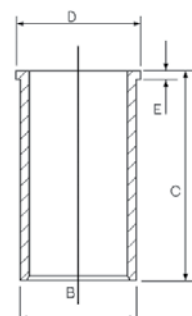

 **82.00**



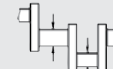

**Diesel**

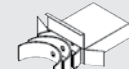

**841 G.000**      5 Cyl.      2387cc      **129kW (175)PS**      **Turbo Intercooled**      **TD18317**      **279**

			
<p><b>87-146100-00</b>      STD</p> <p><b>A</b> 46.50 <b>B-</b> 15.40 <b>BØ</b> 41.50 <b>C</b> 1.03 <b>D</b> 72.50  26x61</p> <p><b>AK KK NB RT TP</b></p>	 <p><b>08256-102</b></p>	<p><b>08-146100-00</b>      STD <b>08-146106-00</b>      0.40mm <b>08-146108-00</b>      0.60mm</p> <p>2.00  CK P 2.00  P 2.00  CK P</p>	<p><b>14-021051-00 D</b> <b>B</b> 85.57    <b>C</b> 155.00    <b>D</b> 88.53    <b>E</b> 4.00</p> 

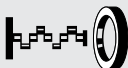
									
BE/PL	1	50.787/50.805	53.901/53.913	19.500	1.534	0.030/0.080	EC	71-3994	<b>71-3994</b> STD 0.25      [22]
MB/HL	1	59.986/60.000	63.705/63.718	20.750	1.844	0.031/0.080	EC	72-3995	<b>72-3995</b> STD 0.25 0.50
TW/A	2	67.785/68.040	82.425/82.677		2.485		AL-LF	4356AF	<b>A191/2</b> STD
SE/PB	1		28.939/28.972	21.700			BS	4369Y	<b>55-4159</b> SEMI

		
<b>ED5910</b>	<b>HR397</b>	<p><b>NA5070</b>  31.00x41.00x7.00mm, FPM</p> <p><b>NF888</b>  93.00x172.00x12.00mm, FPM</p>







**980**



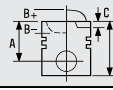
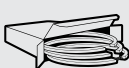





 **82.00**

**Diesel**

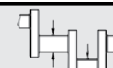





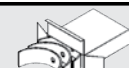



**841 H.000**      5 Cyl.      2387cc      **129kW (175)PS**      **Turbo Intercooled**      **TD18293**      **281**









			
			
	<p><b>08-146100-00</b>      STD <b>08-146106-00</b>      0.40mm <b>08-146108-00</b>      0.60mm</p> <p>2.00  CK P 2.00  P 2.00  CK P</p>		



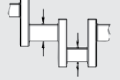
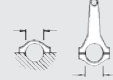



									
BE/PL	1	50.787/50.805	53.901/53.913	19.500	1.534	0.030/0.080	EC	71-3994	<b>71-3994</b> STD 0.25      [22]
MB/HL	1	59.986/60.000	63.705/63.718	20.750	1.844	0.031/0.080	EC	72-3995	<b>72-3995</b> STD 0.25 0.50
TW/A	2	67.785/68.040	82.425/82.677		2.485		AL-LF	4356AF	<b>A191/2</b> STD
SE/PB	1		28.939/28.972	21.700			BS	4369Y	<b>55-4159</b> SEMI

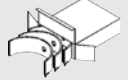

...Continued







<b>980</b>	 <b>82.00</b>	<b>Diesel</b>
		
 ED5910	HR397	<b>NA5070</b>  31.00x41.00x7.00mm, FPM <b>NF888</b>  93.00x172.00x12.00mm, FPM



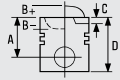



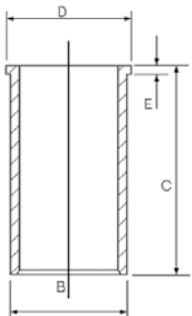

<b>981</b>	 <b>82.00</b>	<b>Diesel</b>				
<b>841 H.000</b>	5 Cyl.	2387cc	<b>129kW (175)PS</b>	<b>Turbo Intercooled</b>	<b>TD20953</b>	<b>280</b>

									
BE/PL	1	50.787/50.805	53.901/53.913	19.500	1.534	0.030/0.080	EC	71-3994	<b>71-3994</b> STD 0.25 [22]
MB/HL	1	59.986/60.000	63.705/63.718	20.750	1.844	0.031/0.080	EC	72-3995	<b>72-3995</b> STD 0.25 0.50
TW/A	2	67.785/68.040	82.425/82.677		2.485		AL-LF	4356AF	<b>A191/2</b> STD
SE/PB	1		28.939/28.972	21.700			BS	4369Y	<b>55-4159</b> SEMI

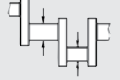
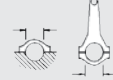
		
 ED5910	HR397	<b>NA5070</b>  31.00x41.00x7.00mm, FPM <b>NF888</b>  93.00x172.00x12.00mm, FPM







<b>982</b>	 <b>82.00</b>	<b>Diesel</b>					
<b>841 M.000</b>	5 Cyl.	18:1	2387cc	<b>120-147kW (163-200)PS</b>	<b>Turbo Intercooled</b>	<b>TD19057</b>	<b>283</b>



			
	<b>08-124000-00</b> STD <b>08-124006-00</b> 0.40mm <b>08-124008-00</b> 0.60mm  2.00  CK P 2.00  P 2.00  CR P	<b>14-021051-00 D</b> <b>B 85.57 C 155.00 D 88.53 E 4.00</b> <b>14-028960-00 D</b> <b>B 85.00 C 155.00 D 88.00 E 4.50</b>  	

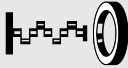





									
BE/PL	1	50.787/50.805	53.901/53.913	19.500	1.534	0.030/0.080	EC	71-3994	<b>71-3994</b> STD 0.25 [22]
MB/HL	1	59.986/60.000	63.705/63.718	20.750	1.844	0.031/0.080	EC	72-3995	<b>72-3995</b> STD 0.25 0.50
TW/A	2	67.785/68.040	82.425/82.677		2.485		AL-LF	4356AF	<b>A191/2</b> STD
SE/PB	1		28.939/28.972	21.700			BS	4369Y	<b>55-4159</b> SEMI



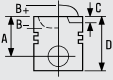





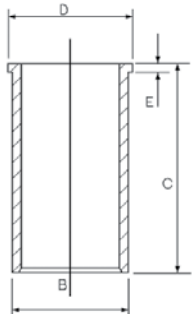

# FIAT GROUP

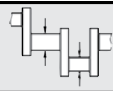
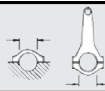





...Continued

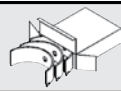

<b>982</b>	 <b>82.00</b>	<b>Diesel</b>
		
 ED5910	HR397	<b>NA5070</b>  31.00x41.00x7.00mm, FPM <b>NF888</b>  93.00x172.00x12.00mm, FPM







<b>983</b>	 <b>82.00</b>	<b>Diesel</b>				
<b>841 N.000</b>	5 Cyl.	2387cc	<b>120kW (163)PS</b>	<b>Turbo Intercooled</b>	<b>TD19058</b>	<b>283</b>

			
	<b>08-124000-00</b> STD <b>08-124006-00</b> 0.40mm <b>08-124008-00</b> 0.60mm  2.00  CK P 2.00  P 2.00  CR P	<b>14-021051-00 D</b> <b>B 85.57 C 155.00 D 88.53 E 4.00</b> <b>14-028960-00 D</b> <b>B 85.00 C 155.00 D 88.00 E 4.50</b>	
			

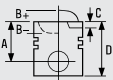





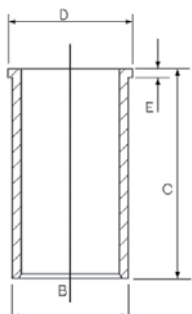



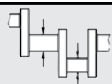
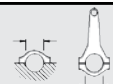

											
BE/PL	1	50.787/50.805	53.901/53.913	19.500	1.534	0.030/0.080	EC-LF	71-4780	<b>71-4780</b>		[23]
MB/HL	1	59.986/60.000	63.705/63.718	20.750	1.844	0.031/0.080	EC	72-3995	<b>72-3995</b>	STD 0.25 0.50	





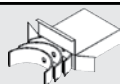
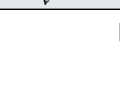
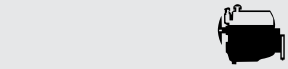







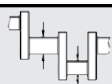
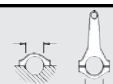

		
 ED5910	HR397	<b>NA5070</b>  31.00x41.00x7.00mm, FPM <b>NF888</b>  93.00x172.00x12.00mm, FPM





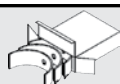
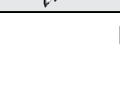
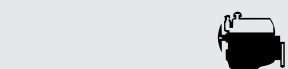







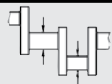
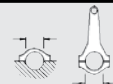

<b>984</b>	 <b>82.00</b>	<b>Diesel</b>				
<b>841 N.000</b>	5 Cyl.	18:1	2387cc	<b>120-147kW (163-200)PS</b>	<b>Turbo Intercooled</b>	<b>TD22510</b>

			
	<b>08-146100-00</b> STD <b>08-146106-00</b> 0.40mm <b>08-146108-00</b> 0.60mm  2.00  CK P 2.00  P 2.00  CK P	<b>14-021051-00 D</b> <b>B 85.57 C 155.00 D 88.53 E 4.00</b> <b>14-028960-00 D</b> <b>B 85.00 C 155.00 D 88.00 E 4.50</b>	
			

...Continued

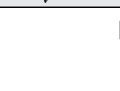
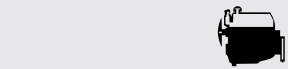
984  82.00 Diesel											
											
BE/PL	1	50.787/50.805	53.901/53.913	19.500	1.534	0.030/0.080	EC-LF	71-4780	<b>71-4780</b> STD	[23]	
MB/HL	1	59.986/60.000	63.705/63.718	20.750	1.844	0.031/0.080	EC	72-3995	<b>72-3995</b> STD 0.25 0.50		
											
ED5910			HR397				NA5070  31.00x41.00x7.00mm, FPM NF888  93.00x172.00x12.00mm, FPM				

985  82.00 Diesel 											
841 P.000		5 Cyl.		2387cc		136kW (185)PS		Turbo Intercooled		TD20954 <b>284</b>	
											
BE/PL	1	50.787/50.805	53.901/53.913	19.500	1.534	0.030/0.080	EC-LF	71-4780	<b>71-4780</b> STD	[23]	
MB/HL	1	59.986/60.000	63.705/63.718	20.750	1.844	0.031/0.080	EC	72-3995	<b>72-3995</b> STD 0.25 0.50		
											
ED5910			HR397				NA5070  31.00x41.00x7.00mm, FPM NF888  93.00x172.00x12.00mm, FPM				

986  82.00 Diesel 											
936 B.000		5 Cyl.		2387cc		136kW (185)PS		Turbocharged		TD20761 <b>285</b>	
											
BE/PL	1	50.787/50.805	53.901/53.913	19.500	1.534	0.030/0.080	EC-LF	71-4780	<b>71-4780</b> STD	[23]	
MB/HL	1	59.986/60.000	63.705/63.718	20.750	1.844	0.031/0.080	EC	72-3995	<b>72-3995</b> STD 0.25 0.50		
											
EG7410			HR397				NA5070  31.00x41.00x7.00mm, FPM NF888  93.00x172.00x12.00mm, FPM				

# FIAT GROUP

## 987

 82.00

Diesel



939 A3.000

5 Cyl.





2387cc





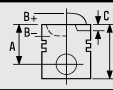
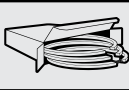

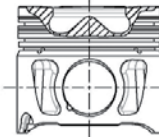
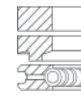
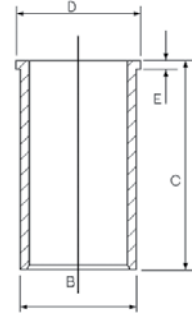
147kW (200)PS

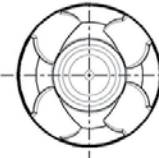

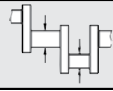
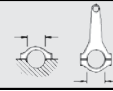

Turbo Intercooled

TD18450

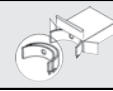
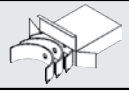
286

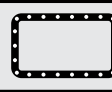
							
<p>87-146100-00 STD</p> <p>87-146108-00 0.60mm</p>		<p>08-146100-00 STD</p> <p>08-146106-00 0.40mm</p> <p>08-146108-00 0.60mm</p>	 <p>2.00 CK P</p> <p>2.00 P</p> <p>2.00 CK P</p>	<p>14-021051-00 D</p> <p>B 85.57 C 155.00 D 88.53 E 4.00</p> <p>14-028960-00 D</p> <p>B 85.00 C 155.00 D 88.00 E 4.50</p>			
<p>A 46.50</p> <p>B- 15.40</p> <p>BØ 41.50</p> <p>C 1.03</p> <p>D 72.50</p> <p> 26x61</p>							
<p>AK KK NB RT TP</p>	<p>08256-102</p>						

									
BE/PL	1	50.787/50.805	53.901/53.913	19.500	1.534	0.030/0.080	EC-LF	71-4780	71-4780 [23]
MB/HL	1	59.986/60.000	63.705/63.718	20.750	1.844	0.031/0.080	EC	72-3995	72-3995 STD 0.25 0.50

		
EG7410	HR397	NA5070  31.00x41.00x7.00mm, FPM NF888  93.00x172.00x12.00mm, FPM

## 988

 82.00

Diesel



939 A3.000 Euro 4 (D4)

5 Cyl.

17:1



2387cc





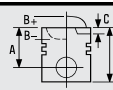
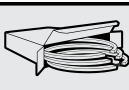

147-154kW (200-209)PS

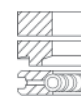
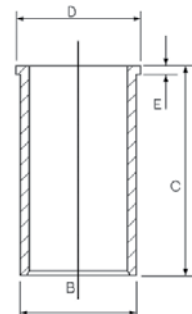
Turbo Intercooled

TD18474

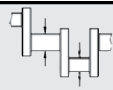
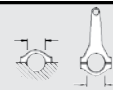
287



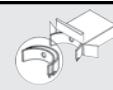
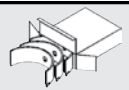

							
		<p>08-146100-00 STD</p> <p>08-146106-00 0.40mm</p> <p>08-146108-00 0.60mm</p>	 <p>2.00 CK P</p> <p>2.00 P</p> <p>2.00 CK P</p>	<p>14-021051-00 D</p> <p>B 85.57 C 155.00 D 88.53 E 4.00</p> <p>14-028960-00 D</p> <p>B 85.00 C 155.00 D 88.00 E 4.50</p>			

									
BE/PL	1	50.787/50.805	53.901/53.913	19.500	1.534	0.030/0.080	EC-LF	71-4780	71-4780 [23]
MB/HL	1	59.986/60.000	63.705/63.718	20.750	1.844	0.031/0.080	EC	72-3995	72-3995 STD 0.25 0.50







...Continued

**988**  **82.00** **Diesel**

		
EG7410	HR397	NA5070  31.00x41.00x7.00mm, FPM NF888  93.00x172.00x12.00mm, FPM









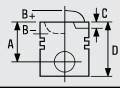
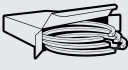

**989**  **82.00** **Diesel** 

939 A9.000      5 Cyl.      17:1      2387cc      154kW (210)PS      Turbo Intercooled      TD20935      **288**

		
EG7410	HR397	NA5070  31.00x41.00x7.00mm, FPM NF888  93.00x172.00x12.00mm, FPM

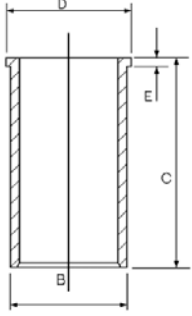
**990**  **82.00** **Diesel** 









AR 36202      5 Cyl.      2387cc      103kW (140)PS      TD15636      **291**

			
<p>87-107900-00      STD</p> <p>87-107908-00      0.60mm</p> <p>A 46.50</p> <p>B- 17.50</p> <p>BØ 37.50</p> <p>C 0.80</p> <p>D 72.50</p> <p> 26x65</p> <p>AK RT</p>	<p>08-107900-00      STD</p> <p>08-107908-00      0.60mm</p> <p>2.50  CR P</p> <p>2.00  P</p> <p>2.00  CR P</p>	<p>14-021051-00 D</p> <p>B 85.57    C 155.00    D 88.53    E 4.00</p> <p>14-028960-00 D</p> <p>B 85.00    C 155.00    D 88.00    E 4.50</p> <p></p>	
<p>87-124000-30      STD</p> <p>87-124008-30      0.60mm</p> <p>A 46.50</p> <p>B- 17.45</p> <p>BØ 37.55</p> <p>C 0.65</p> <p>D 72.50</p> <p> 26x61</p> <p>NB RT</p>	<p>08-124000-00      STD</p> <p>08-124006-00      0.40mm</p> <p>08-124008-00      0.60mm</p> <p>2.00  CK P</p> <p>2.00  P</p> <p>2.00  CR P</p>		

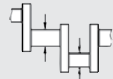
# FIAT GROUP

...Continued



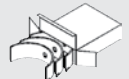

## 990 82.00 Diesel

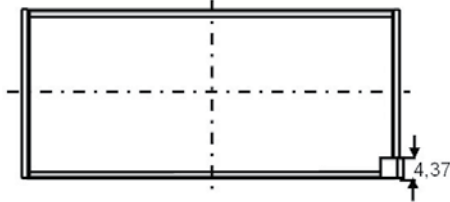
									
BE/PL	5	50.787/50.805	53.901/53.913	19.500	1.534	0.030/0.080	EC	71-3958	<b>71-3958/5</b> .010
BE/PL	1	50.787/50.805	53.901/53.913	19.500	1.534	0.030/0.080	EC	71-3994	<b>71-3994</b> STD 0.25

71-3994













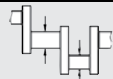

MB/HL 1-6	6	59.986/60.000	63.705/63.718	20.750	1.844	0.031/0.075	BS	4356CP	<b>H1095/6</b> STD 0.25 0.50
TW/A	2	67.785/68.040	82.425/82.677		2.485		AL-LF	4356AF	<b>A191/2</b> STD
SE/PB	1		28.939/28.972	21.700			BS	4369Y	<b>55-4159</b> SEMI

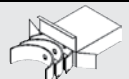

		
	HR397	NA5070  31.00x41.00x7.00mm, FPM NF888  93.00x172.00x12.00mm, FPM



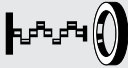



## 991 82.20 Diesel



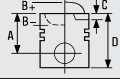
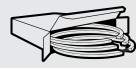

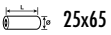
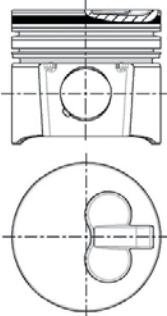

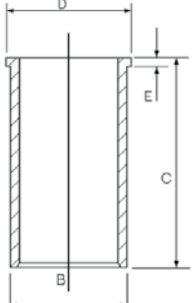

WJY (DW8)	4 Cyl.	23:1	1868cc	51kW (69)PS	TD21266	<b>292</b>
WJY (DW8B)	4 Cyl.	23:1	1868cc	51kW (69)PS	TD22240	<b>293</b>



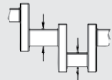
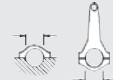

									
BE/PL	4	49.984/50.000	53.695/53.708	20.050	1.830	0.040/0.090	AL-LF	66725RA	<b>01-4200/4</b> STD 0.30 0.50
MB/HL 1-5	5	59.981/60.000	63.731/63.750	20.290	1.845	0.040/0.100	AL-LF	66726RA	<b>H1057/5</b> STD 0.30 0.50
TW/A	2	67.050/67.300	83.050/83.300		2.330		BS	54-3954	<b>A160/4</b> STD
TW/A	2	67.050/67.300	83.050/83.300		2.330		BS	54-3955	
SE/PB	1	25.007/25.020	27.200/27.221	24.050			BS	66729YA	<b>55-4201</b> SEMI

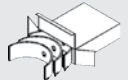

		
EA5830	PB907 14.00x21.00x2.000mm	NA5191  42.00x62.00x7.00mm, PTFE NA5192  90.00x110.00x7.00mm, PTFE









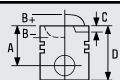
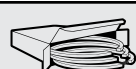

<b>992</b>	 <b>82.20</b>	<b>Diesel</b>	
<b>WJZ (DW8)</b>	4 Cyl.	23:1	1868cc
			<b>51-52kW (69-71)PS</b>
			<b>TD16300</b>
			<b>294</b>

			
<b>87-104000-00</b> STD <b>87-104008-00</b> 0.60mm  <b>A</b> 46.80 <b>B-</b> 1.30 <b>D</b> 78.00  25x65	  <b>08-104000-00</b> STD <b>08-104008-00</b> 0.60mm  2.00  CK P 2.00  P 3.00  CR P	<b>14-020290-00 D</b> <b>B</b> 85.00 <b>C</b> 154.00 <b>D</b> 87.00 <b>E</b> 5.00  	



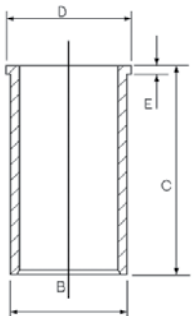

									
BE/PL	4	49.984/50.000	53.695/53.708	20.050	1.830	0.040/0.090	AL-LF	66725RA	<b>01-4200/4</b> STD 0.30 0.50
MB/HL 1-5	5	59.981/60.000	63.731/63.750	20.290	1.845	0.040/0.100	AL-LF	66726RA	<b>H1057/5</b> STD 0.30 0.50
TW/A	2	67.050/67.300	83.050/83.300		2.330		BS	54-3954	<b>A160/4</b> STD
TW/A	2	67.050/67.300	83.050/83.300		2.330		BS	54-3955	
SE/PB	1	25.007/25.020	27.200/27.221	24.050			BS	66729YA	<b>55-4201</b> SEMI





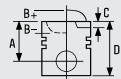



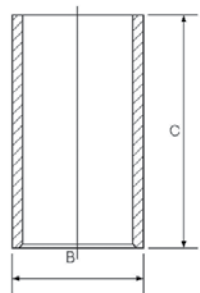

		
<b>EA5830</b>	<b>PB907</b> 14.00x21.00x2.000mm	<b>NA5191</b>  42.00x62.00x7.00mm, PTFE <b>NA5192</b>  90.00x110.00x7.00mm, PTFE

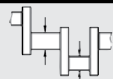
<b>993</b>	 <b>82.60</b>	<b>Diesel</b>	
<b>138 C.000</b>	4 Cyl.	20:1	1698cc
			<b>44kW (60)PS</b>
			<b>TD925</b>
			<b>298</b>
<b>149 B4.046</b>	4 Cyl.	20:1	1697cc
			<b>42-44kW (57-60)PS</b>
			<b>TD969</b>
			<b>297</b>





			
	<b>08-782300-00</b> STD <b>08-782308-00</b> 0.60mm eng. →690650  2.50  MOL P 2.00  P 4.00  CR P	<b>14-021551-00 D</b> <b>B</b> 85.66 <b>C</b> 142.00 <b>D</b> 89.00 <b>E</b> 4.50 <b>14-023751-00 D</b> <b>B</b> 87.00 <b>C</b> 154.00 <b>D</b> 89.00 <b>E</b> 4.55 <b>14-785400-00 D</b> <b>B</b> 86.00 <b>C</b> 144.00 <b>D</b> 89.00 <b>E</b> 4.50  	
	<b>08-785400-00</b> STD <b>08-785408-00</b> 0.60mm eng. 690651 →  2.50  MOL P 2.00  P 3.00  CR P		

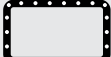
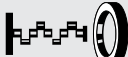

**993**  **82.60** **Diesel**









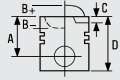
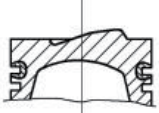
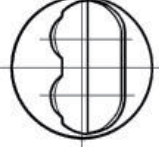
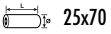
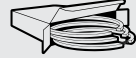

			
		<p><b>14-014730-00 D</b>  <b>B 86.09 C 154.00</b></p> 	



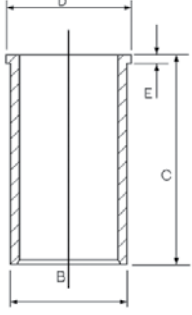

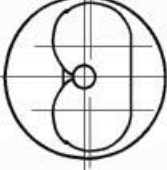
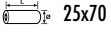



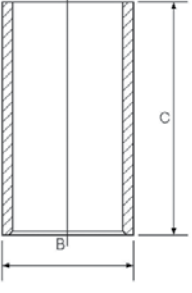

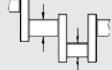

									
BE/PL	4	50.782/50.802	53.897/53.913	19.500	1.537	0.021/0.082	AL-LF	66240RA	<b>01-4175/4</b> STD 0.25 0.50 0.75 1.00
MB/HL 1,2,4,5	4	52.985/53.005	56.717/56.730	20.750	1.841	0.030/0.088	AL-LF	66316RA	<b>H1043/5</b> STD 0.25 0.50 0.75
MB/HL 3	1	52.985/53.005	56.717/56.730	24.250	1.841	0.030/0.088	AL-LF	66317RA	
TW/A	2	59.000/59.250	73.600/73.850		2.362		BS	62037AF	<b>A201/2</b> STD .005
SE/PB	1	25.004/25.010	26.939/26.972	25.400			BS	66644Y	<b>55-4190</b> SEMI

		
---	---	---

<p> <b>EV684</b></p>	<p><b>JJ298</b> (Cork) <b>JJ398</b></p>   <p><b>JJ298</b>                      <b>JJ398</b></p>	<p><b>NB742</b>  30.00x43.00x8.00mm, ACM  <b>NB732</b>  74.00x90.00x10.00mm, FPM</p>
--	---	--

<b>994</b>	 <b>82.60</b>	<b>Diesel</b>				
<b>146 B2.000</b>	4 Cyl.	20.5:1	1698cc	<b>42-44kW (57-60)PS</b>	<b>TD949</b>	<b>299</b>
<b>149 B3.000</b>	4 Cyl.	20.5:1	1698cc	<b>44kW (60)PS</b>	<b>TD967</b>	<b>301</b>
<b>149 B4.000</b>	4 Cyl.	20:1	1697cc	<b>42-45kW (57-61)PS</b>	<b>TD968</b>	<b>296</b>
<b>176 B3.000</b>	4 Cyl.	20.5:1	1698cc	<b>42kW (57)PS</b>	<b>TD9477</b>	<b>304</b>





 <p><b>87-782300-00</b> <b>87-782308-00</b> eng. →690650</p> <p>STD 0.60mm</p>   <p>A 42.60 B+ 2.40 D 81.80  25x70</p> <p>RT</p>	 <p><b>08-782300-00</b> STD <b>08-782308-00</b> 0.60mm eng. →690650</p> <p>2.50  MOL P 2.00  P 4.00  CR P</p>	 <p><b>14-021551-00 D</b> B 85.66 C 142.00 D 89.00 E 4.50 <b>14-023751-00 D</b> B 87.00 C 154.00 D 89.00 E 4.55 <b>14-785400-00 D</b> B 86.00 C 144.00 D 89.00 E 4.50</p> 	
<p><b>87-785400-00</b> <b>87-785408-00</b> eng. 690651 →</p> <p>STD 0.60mm</p>   <p>A 42.60 B+ 2.50 D 75.80  25x70</p> <p>RT</p>	<p><b>08-785400-00</b> STD <b>08-785408-00</b> 0.60mm eng. 690651 →</p> <p>2.50  MOL P 2.00  P 3.00  CR P</p>	<p><b>14-014730-00 D</b> B 86.09 C 154.00</p> 	

												
BE/PL	4	50.782/50.802	53.897/53.913	19.500	1.537	0.021/0.082	AL-LF	66240RA	<b>01-4175/4</b> STD 0.25 0.50 0.75 1.00			
MB/HL 1,2,4,5	4	52.985/53.005	56.717/56.730	20.750	1.841	0.030/0.088	AL-LF	66316RA	<b>H1043/5</b> STD 0.25 0.50 0.75			
MB/HL 3	1	52.985/53.005	56.717/56.730	24.250	1.841	0.030/0.088	AL-LF	66317RA				
TW/A	2	59.000/59.250	73.600/73.850		2.362		BS	62037AF	<b>A201/2</b> STD .005			
SE/PB	1	25.004/25.010	26.939/26.972	25.400			BS	66644Y	<b>55-4190</b> SEMI			

# FIAT GROUP



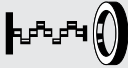

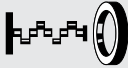
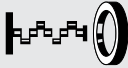

...Continued



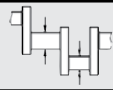
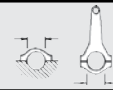

## 994 82.60 Diesel

		
<b>EV684</b>	<b>JJ298</b> (Cork) <b>JJ398</b>  <b>JJ298</b>  <b>JJ398</b>	<b>NB742</b>  30.00x43.00x8.00mm, ACM <b>NB732</b>  74.00x90.00x10.00mm, FPM

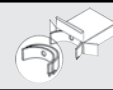
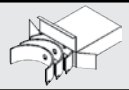
## 995 82.60 Diesel



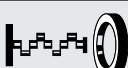

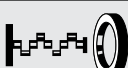
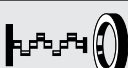

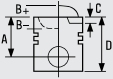
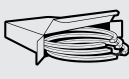

149 B2.000 4 Cyl. 20:1 1697cc 42kW (57)PS TD16864 295

									
BE/PL	4	50.782/50.802	53.897/53.913	19.500	1.537	0.021/0.082	AL-LF	66240RA	<b>01-4175/4</b> STD 0.25 0.50 0.75 1.00
MB/HL 1,2,4,5	4	52.985/53.005	56.717/56.730	20.750	1.841	0.030/0.088	AL-LF	66316RA	<b>H1043/5</b> STD 0.25 0.50 0.75
MB/HL 3	1	52.985/53.005	56.717/56.730	24.250	1.841	0.030/0.088	AL-LF	66317RA	
TW/A	2	59.000/59.250	73.600/73.850		2.362		BS	62037AF	<b>A201/2</b> STD .005
SE/PB	1	25.004/25.010	26.939/26.972	25.400			BS	66644Y	<b>55-4190</b> SEMI

		
<b>EV684</b>	<b>JJ298</b> (Cork)  <b>JJ298</b>	<b>NB742</b>  30.00x43.00x8.00mm, ACM <b>NB732</b>  74.00x90.00x10.00mm, FPM



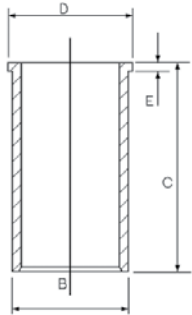

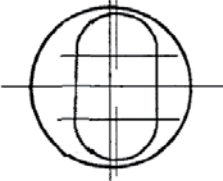

## 996 82.60 Diesel



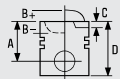
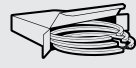

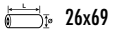
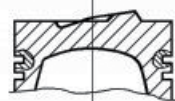
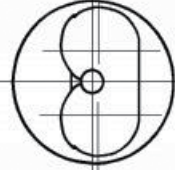





146 D7.000 4 Cyl. 20:1 1698cc 46kW (63)PS Turbocharged TD9472 300

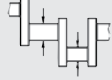
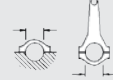





			
<b>87-783800-00</b> <b>87-783808-00</b>	STD 0.60mm 	<b>08-783800-00</b> STD <b>08-783808-00</b> 0.60mm 3.00  MOL P 2.00  P 3.00  CR P	<b>14-021551-00 D</b> B 85.66 C 142.00 D 89.00 E 4.50 
A 42.80 B+ 2.60 D 78.60  26x69 AK RT			



...Continued

**996**  **82.60** **Diesel**







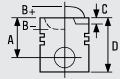
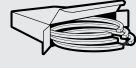

			
<b>87-783800-30</b> <b>87-783808-30</b> STD 0.60mm  <b>A</b> 42.40 <b>B+</b> 2.50 <b>D</b> 76.00  26x69  <b>HA RT</b>	   <b>08-783800-00</b> STD <b>08-783808-00</b> 0.60mm  3.00  MOL P 2.00  P 3.00  CR P		

										
BE/PL	4	50.787/50.807	53.901/53.913	19.500	1.534	0.028/0.083	BS	4350CP	<b>71-4157/4</b> STD 0.25 0.50	
MB/HL 1,2,4,5	4	52.990/53.010	56.717/56.735	20.750	1.843	0.020/0.080	BS	4128CP	<b>H1084/5</b> STD 0.25 0.50	
MB/HL 3	1	52.990/53.010	56.717/56.735	24.250	1.843	0.020/0.080	BS	4129CP		
TW/A	2	59.000/59.250	73.600/73.850		2.362		BS	62037AF	<b>A201/2</b> STD .005	
SE/PB	1	25.500/25.640	27.939/27.972	23.800			BS	66644YB	<b>55-4233</b> SEMI	

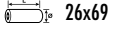
		
<b>EV684</b>	<b>JJ298</b> (Cork) →Eng.9185 <b>JJ398</b> Eng.9186 →   <b>JJ298</b>  <b>JJ398</b>	<b>NB742</b>  30.00x43.00x8.00mm, ACM <b>NB732</b>  74.00x90.00x10.00mm, FPM

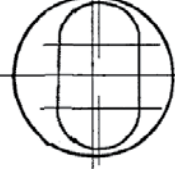
**997**  **82.60** **Diesel** 

**176 A3.000** 4 Cyl. 20.3:1 1698cc **51-53kW (69-72)PS** **Turbocharged** **TD1033** **302**

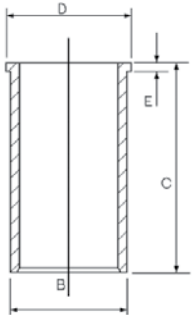
			
<b>87-783800-10</b> <b>87-783808-10</b> STD 0.60mm  <b>A</b> 43.00 <b>B+</b> 2.30 <b>D</b> 76.00  26x69  <b>AK HA RT</b>	   <b>08-783800-00</b> STD <b>08-783808-00</b> 0.60mm  3.00  MOL P 2.00  P 3.00  CR P	<b>14-021551-00 D</b> <b>B</b> 85.66 <b>C</b> 142.00 <b>D</b> 89.00 <b>E</b> 4.50  	

# FIAT GROUP

...Continued

997		82.60	Diesel						
BE/PL	4	50.787/50.807	53.901/53.913	19.500	1.534	0.028/0.083	BS	4350CP	71-4157/4 STD 0.25 0.50
MB/HL 1,2,4,5	4	52.990/53.010	56.717/56.735	20.750	1.843	0.020/0.080	BS	4128CP	H1084/5 STD 0.25 0.50
MB/HL 3	1	52.990/53.010	56.717/56.735	24.250	1.843	0.020/0.080	BS	4129CP	
TW/A	2	59.000/59.250	73.600/73.850		2.362		BS	62037AF	A201/2 STD .005
SE/PB	1	25.500/25.640	27.939/27.972	23.800			BS	66644YB	55-4233 SEMI

EV684	JJ298 (Cork) JJ398	NB742  30.00x43.00x8.00mm, ACM NB732  74.00x90.00x10.00mm, FPM
	JJ298	JJ398

998		82.60	Diesel				
176 A5.000	4 Cyl.	19.1:1	1698cc	52-59kW (71-80)PS	Turbocharged	TD1035	303
176 B7.000	4 Cyl.	19.1:1	1698cc	46-47kW (63-64)PS	Turbocharged	TD5493	302

87-783800-00 87-783808-00	87-783800-30 87-783808-30	08-783800-00 08-783808-00	14-021551-00 D	
STD 0.60mm	STD 0.60mm	STD 0.60mm	B 85.66 C 142.00 D 89.00 E 4.50	
A 42.80 B+ 2.60 D 78.60 26x69	A 42.40 B+ 2.50 D 76.00 26x69	3.00 MOL P 2.00 P 3.00 CR P		
AK RT	HA RT			



...Continued

998		82.60		Diesel					
BE/PL	4	50.787/50.807	53.901/53.913	19.500	1.534	0.028/0.083	BS	4350CP	71-4157/4 STD 0.25 0.50
MB/HL 1,2,4,5	4	52.990/53.010	56.717/56.735	20.750	1.843	0.020/0.080	BS	4128CP	H1084/5 STD 0.25 0.50
MB/HL 3	1	52.990/53.010	56.717/56.735	24.250	1.843	0.020/0.080	BS	4129CP	
TW/A	2	59.000/59.250	73.600/73.850		2.362		BS	62037AF	A201/2 STD .005
SE/PB	1	25.500/25.640	27.939/27.972	23.800			BS	66644YB	55-4233 SEMI

EV684	JJ298 (Cork) JJ398  JJ298	NB742  30.00x43.00x8.00mm, ACM NB732  74.00x90.00x10.00mm, FPM
	 JJ398	

999		82.60		Diesel					
178 C9.066		4 Cyl.	20.3:1	1698cc	46-52kW (63-71)PS		Turbo Intercooled		TD23865
BE/PL	4	50.787/50.807	53.901/53.913	19.500	1.534	0.028/0.083	BS	4350CP	71-4157/4 STD 0.25 0.50
MB/HL 1,2,4,5	4	52.990/53.010	56.717/56.735	20.750	1.843	0.020/0.080	BS	4128CP	H1084/5 STD 0.25 0.50
MB/HL 3	1	52.990/53.010	56.717/56.735	24.250	1.843	0.020/0.080	BS	4129CP	
TW/A	2	59.000/59.250	73.600/73.850		2.362		BS	62037AF	A201/2 STD .005
SE/PB	1	25.500/25.640	27.939/27.972	23.800			BS	66644YB	55-4233 SEMI

**1000**

**82.60**

**Diesel**



831 D.000      4 Cyl.      21:1      1911cc      48kW (65)PS      TD1813      305

	<p><b>08-783800-00</b> STD</p> <p><b>08-783808-00</b> 0.60mm</p> <p>3.00  MOL P</p> <p>2.00  P</p> <p>3.00  CR P</p>	<p><b>14-021311-00 D</b></p> <p><b>B</b> 86.06    <b>C</b> 154.00    <b>D</b> 89.00    <b>E</b> 4.50</p> <p><b>14-023751-00 D</b></p> <p><b>B</b> 87.00    <b>C</b> 154.00    <b>D</b> 89.00    <b>E</b> 4.55</p>	

BE/PL	4	50.787/50.807	53.892/53.910	19.500	1.537	0.020/0.070	BS	1040CP	71-4118/4 STD 0.25 0.50

→02/89

MB/HL 1,2,4,5	4	52.990/53.010	56.717/56.735	20.750	1.843	0.020/0.080	BS	4128CP	<b>H1084/5</b> STD 0.25 0.50
MB/HL 3	1	52.990/53.010	56.717/56.735	24.250	1.843	0.020/0.080	BS	4129CP	
TW/A	2	59.000/59.250	73.600/73.850		2.362		BS	62037AF	<b>A201/2</b> STD .005
SE/PB	1	25.004/25.010	26.939/26.972	25.400			BS	66644Y	<b>55-4190</b> SEMI
SE/PB	1	26.004/26.010	27.939/27.972	25.400			BS	66644YA	<b>55-4232</b> SEMI
SE/PB	1	25.500/25.640	27.939/27.972	23.800			BS	66644YB	<b>55-4233</b> SEMI

66644Y

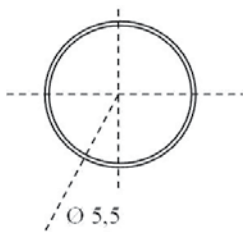

66644YA

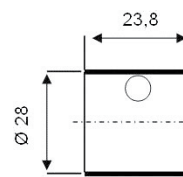
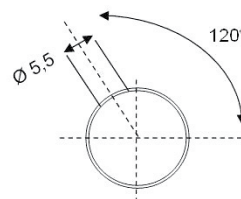
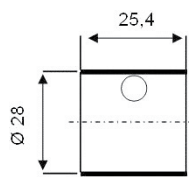

66644YB

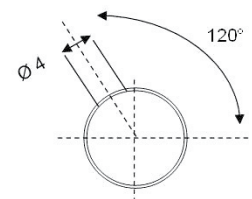

--	--	--

EV684

JJ298

(Cork)

JJ398



JJ298



JJ398

NB742 30.00x43.00x8.00mm, ACM

NB732 74.00x90.00x10.00mm, FPM







## 1001



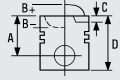
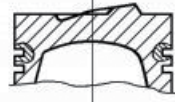

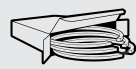

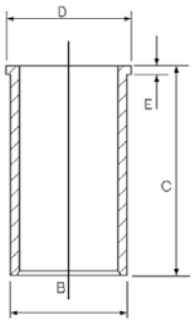

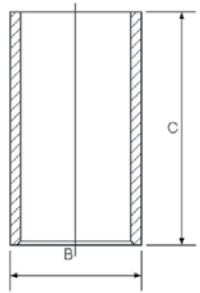
### 82.60



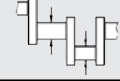
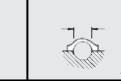

### Diesel



<b>149 A1.000</b>	4 Cyl.	21:1	1929cc	<b>48kW (65)PS</b>	<b>TD4378</b>	<b>306</b>
<b>149 B1.000</b>	4 Cyl.	21:1	1929cc	<b>51-52kW (70-71)PS</b>	<b>TD963</b>	<b>307</b>
<b>160 A7.000</b>	4 Cyl.	21:1	1929cc	<b>48kW (65)PS</b>	<b>TD1023</b>	<b>313</b>

 <p><b>87-785400-00</b> <b>87-785408-00</b></p> <p>STD 0.60mm</p>   <p>A 42.60 B+ 2.50 D 75.80 25x70</p> <p>RT</p>	 <p><b>08-785400-00</b> STD <b>08-785408-00</b> 0.60mm eng. 690651 →</p> <p>2.50 MOL P 2.00 P 3.00 CR P</p>	 <p><b>14-021311-00 D</b> B 86.06 C 154.00 D 89.00 E 4.50 <b>14-023560-00 D</b> B 86.00 C 154.00 D 89.00 E 4.50 <b>14-023751-00 D</b> B 87.00 C 154.00 D 89.00 E 4.55</p> 	 <p><b>14-014730-00 D</b> B 86.09 C 154.00</p> 
---	--	---	--

									
BE/PL	4	50.782/50.802	53.897/53.913	19.500	1.537	0.021/0.082	AL-LF	66240RA	<b>01-4175/4</b> STD 0.25 0.50 0.75 1.00
MB/HL 1,2,4,5	4	52.985/53.005	56.717/56.730	20.750	1.841	0.030/0.088	AL-LF	66316RA	<b>H1043/5</b> STD 0.25 0.50 0.75
MB/HL 3	1	52.985/53.005	56.717/56.730	24.250	1.841	0.030/0.088	AL-LF	66317RA	
TW/A	2	59.000/59.250	73.600/73.850		2.362		BS	62037AF	<b>A201/2</b> STD .005
SE/PB	1	25.004/25.010	26.939/26.972	25.400			BS	66644Y	<b>55-4190</b> SEMI

 <p><b>EV684</b></p>	 <p><b>JJ298</b> (Cork) <b>JJ398</b></p>  <p><b>JJ298</b>      <b>JJ398</b></p>	 <p><b>NB742</b> 30.00x43.00x8.00mm, ACM <b>NB732</b> 74.00x90.00x10.00mm, FPM</p>
---	---	---

## 1002

### 82.60

### Diesel



149 B5.046

4 Cyl.

20:1

1929cc

44kW (60)PS

TD9602

308

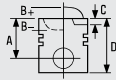

**08-785400-00** STD  
**08-785408-00** 0.60mm  
 eng. 690651 →





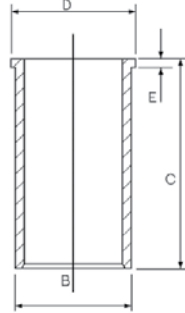

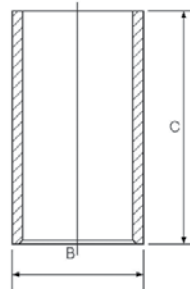

2.50  MOL P  
 2.00  P  
 3.00  CR P

**14-021311-00 D**  
 B 86.06 C 154.00 D 89.00 E 4.50  
**14-023560-00 D**  
 B 86.00 C 154.00 D 89.00 E 4.50  
**14-023751-00 D**  
 B 87.00 C 154.00 D 89.00 E 4.55

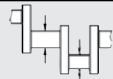

**14-014730-00 D**  
 B 86.09 C 154.00



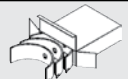

									
BE/PL	4	50.787/50.807	53.901/53.913	19.500	1.534	0.028/0.083	BS	4350CP	<b>71-4157/4</b> STD 0.25 0.50
MB/HL 1,2,4,5	4	52.990/53.010	56.717/56.735	20.750	1.843	0.020/0.080	BS	4128CP	<b>H1084/5</b> STD 0.25 0.50
MB/HL 3	1	52.990/53.010	56.717/56.735	24.250	1.843	0.020/0.080	BS	4129CP	
TW/A	2	59.000/59.250	73.600/73.850		2.362		BS	62037AF	<b>A201/2</b> STD .005
SE/PB	1	25.500/25.640	27.939/27.972	23.800			BS	66644YB	<b>55-4233</b> SEMI



 EV684

JJ298  
 (Cork)  
 JJ398

**NB742**  30.00x43.00x8.00mm, ACM  
**NB732**  74.00x90.00x10.00mm, FPM



JJ298

JJ398

## 1003

## 82.60

## Diesel



154 B.000

4 Cyl.

20:1

1929cc

68kW (92)PS

Turbo Intercooled

TD21460

309

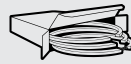
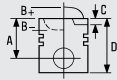

**08-783400-00** STD

2.50 MOL P

2.00 P

4.00 CR P

**14-021311-00 D**  
**B 86.06 C 154.00 D 89.00 E 4.50**

**14-023560-00 D**  
**B 86.00 C 154.00 D 89.00 E 4.50**

**14-023751-00 D**  
**B 87.00 C 154.00 D 89.00 E 4.55**

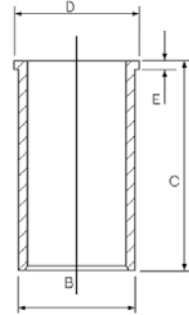

**14-014730-00 D**  
**B 86.09 C 154.00**

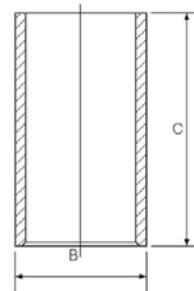

BE/PL	4	50.787/50.807	53.901/53.913	19.500	1.534	0.028/0.083	BS	4350CP	<b>71-4157/4</b> STD 0.25 0.50
MB/HL 1,2,4,5	4	52.990/53.010	56.717/56.735	20.750	1.843	0.020/0.080	BS	4128CP	<b>H1084/5</b> STD 0.25 0.50
MB/HL 3	1	52.990/53.010	56.717/56.735	24.250	1.843	0.020/0.080	BS	4129CP	
TW/A	2	59.000/59.250	73.600/73.850		2.362		BS	62037AF	<b>A201/2</b> STD .005
SE/PB	1	25.500/25.640	27.939/27.972	23.800			BS	66644YB	<b>55-4233</b> SEMI



**JJ298**  
(Cork)



**JJ298**

**NB742** 30.00x43.00x8.00mm, ACM  
**NB732** 74.00x90.00x10.00mm, FPM

## 1004

### 82.60

### Diesel



154 C6.000

4 Cyl.

18:1

1929cc

66-68kW (90-92)PS

Turbo Intercooled

TD9621

310

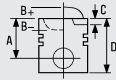

87-783400-00

STD

A 43.00  
B- 13.20  
BØ 43.50  
D 71.00  
26x65

AK RT

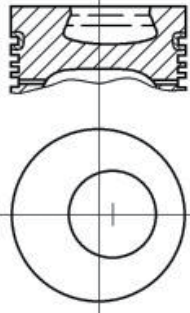

08-783400-00

STD

2.50 MOL P  
2.00 P  
4.00 CR P



14-021311-00 D

B 86.06 C 154.00 D 89.00 E 4.50

14-023560-00 D

B 86.00 C 154.00 D 89.00 E 4.50

14-023751-00 D

B 87.00 C 154.00 D 89.00 E 4.55

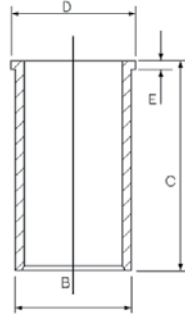

14-014730-00 D

B 86.09 C 154.00

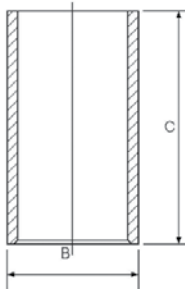











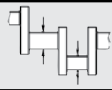
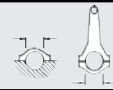

BE/PL	4	50.787/50.807	53.901/53.913	19.500	1.534	0.028/0.083	BS	4350CP	71-4157/4 STD 0.25 0.50
MB/HL 1,2,4,5	4	52.990/53.010	56.717/56.735	20.750	1.843	0.020/0.080	BS	4128CP	H1084/5 STD 0.25 0.50
MB/HL 3	1	52.990/53.010	56.717/56.735	24.250	1.843	0.020/0.080	BS	4129CP	
TW/A	2	59.000/59.250	73.600/73.850		2.362		BS	62037AF	A201/2 STD .005
SE/PB	1	25.500/25.640	27.939/27.972	23.800			BS	66644YB	55-4233 SEMI

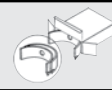
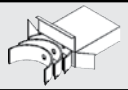









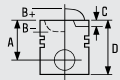
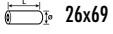

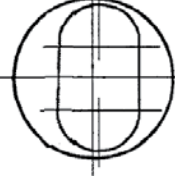
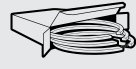

NB742 30.00x43.00x8.00mm, ACM

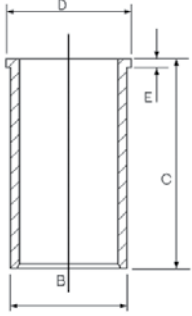
NB732 74.00x90.00x10.00mm, FPM

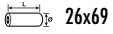
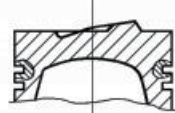
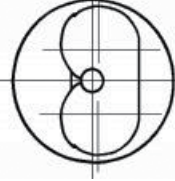
<b>1005</b>		 <b>82.60</b>	<b>Diesel</b>							
<b>154 D1.000</b>		4 Cyl.	20:1	1929cc	<b>69kW (94)PS</b>		<b>Turbo Intercooled</b>		<b>TD9622</b>	<b>310</b>
										
BE/PL	4	50.787/50.807	53.901/53.913	19.500	1.534	0.028/0.083	BS	4350CP	<b>71-4157/4</b> STD 0.25 0.50	
MB/HL 1,2,4,5	4	52.990/53.010	56.717/56.735	20.750	1.843	0.020/0.080	BS	4128CP	<b>H1084/5</b> STD 0.25 0.50	
MB/HL 3	1	52.990/53.010	56.717/56.735	24.250	1.843	0.020/0.080	BS	4129CP		
TW/A	2	59.000/59.250	73.600/73.850		2.362		BS	62037AF	<b>A201/2</b> STD .005	
SE/PB	1	25.500/25.640	27.939/27.972	23.800			BS	66644YB	<b>55-4233</b> SEMI	
										
						<b>NB742</b>  30.00x43.00x8.00mm, ACM <b>NB732</b>  74.00x90.00x10.00mm, FPM				



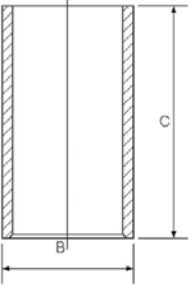





<b>1006</b>		 <b>82.60</b>	<b>Diesel</b>							
<b>160 A6.000</b>		4 Cyl.	19.2:1	1929cc	<b>66-68kW (90-92)PS</b>		<b>Turbo Intercooled</b>		<b>TD4394</b>	<b>311</b>
<b>160 A6.046</b>		4 Cyl.	19.2:1	1929cc	<b>66kW (90)PS</b>		<b>Turbo Intercooled</b>		<b>TD1022</b>	<b>312</b>
<b>160 B6.046</b>		4 Cyl.		1929cc	<b>59kW (82)PS</b>		<b>Turbo Intercooled</b>		<b>TD1025</b>	<b>314</b>
<b>160 D1.000</b>		4 Cyl.		1929cc	<b>65-66kW (88-90)PS</b>		<b>Turbo Intercooled</b>		<b>TD1026</b>	<b>315</b>

 <b>87-783800-10</b> <b>87-783808-10</b> STD 0.60mm A 43.00 B+ 2.30 D 76.00  26x69 <b>AK HA RT</b>	 	 <b>08-783800-00</b> STD <b>08-783808-00</b> 0.60mm 3.00  MOL P 2.00  P 3.00  CR P	 <b>14-021311-00 D</b> <b>B 86.06 C 154.00 D 89.00 E 4.50</b> <b>14-023560-00 D</b> <b>B 86.00 C 154.00 D 89.00 E 4.50</b> <b>14-023751-00 D</b> <b>B 87.00 C 154.00 D 89.00 E 4.55</b> 	
<b>87-783800-30</b> <b>87-783808-30</b> STD 0.60mm A 42.40 B+ 2.50 D 76.00  26x69 <b>HA RT</b>	 	<b>08-783800-00</b> STD <b>08-783808-00</b> 0.60mm 3.00  MOL P 2.00  P 3.00  CR P	<b>14-014730-00 D</b> <b>B 86.09 C 154.00</b> 	

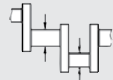
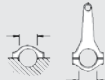
# FIAT GROUP

...Continued

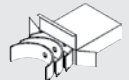

## 1006 82.60 Diesel

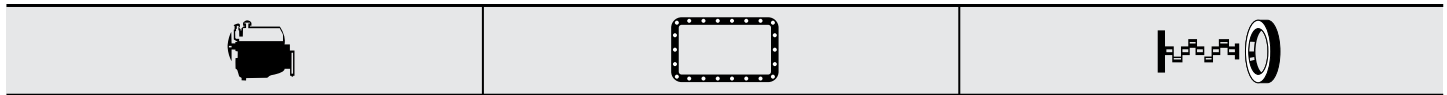
									
BE/PL	4	50.787/50.807	53.901/53.913	19.500	1.534	0.028/0.083	BS	4350CP	<b>71-4157/4</b> STD 0.25 0.50
MB/HL 1,2,4,5	4	52.990/53.010	56.717/56.735	20.750	1.843	0.020/0.080	BS	4128CP	<b>H1084/5</b> STD 0.25 0.50
MB/HL 3	1	52.990/53.010	56.717/56.735	24.250	1.843	0.020/0.080	BS	4129CP	
TW/A	2	59.000/59.250	73.600/73.850		2.362		BS	62037AF	<b>A201/2</b> STD .005
SE/PB	1	26.004/26.010	27.939/27.972	25.400			BS	66644YA	<b>55-4232</b> SEMI



 EV684

JJ298  
(Cork)  
JJ398

NB742  30.00x43.00x8.00mm, ACM  
NB732  74.00x90.00x10.00mm, FPM













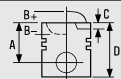
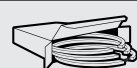

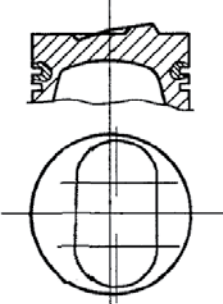

JJ298

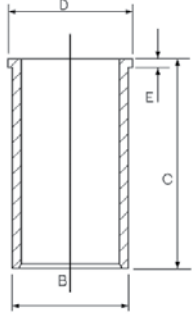

JJ398

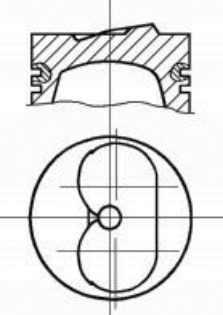
## 1007 82.60 Diesel









160 D1.000      4 Cyl.      19.2:1      1929cc      66kW (90)PS      Turbo Intercooled      TD4610      **316**

			
<p><b>87-783800-10</b>      STD</p> <p><b>87-783808-10</b>      0.60mm</p> <p>A 43.00 B+ 2.30 D 76.00  26x69</p> <p>AK HA RT</p> 	<p><b>08-783800-00</b>      STD</p> <p><b>08-783808-00</b>      0.60mm</p> <p>3.00  MOL P 2.00  P 3.00  CR P</p>	<p><b>14-021311-00 D</b> B 86.06    C 154.00    D 89.00    E 4.50</p> <p><b>14-023751-00 D</b> B 87.00    C 154.00    D 89.00    E 4.55</p> 	
<p><b>87-783800-30</b>      STD</p> <p><b>87-783808-30</b>      0.60mm</p> <p>A 42.40 B+ 2.50 D 76.00  26x69</p> <p>HA RT</p> 	<p><b>08-783800-00</b>      STD</p> <p><b>08-783808-00</b>      0.60mm</p> <p>3.00  MOL P 2.00  P 3.00  CR P</p>		

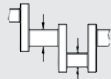
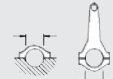

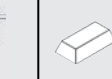

...Continued

**1007**  **82.60 Diesel**

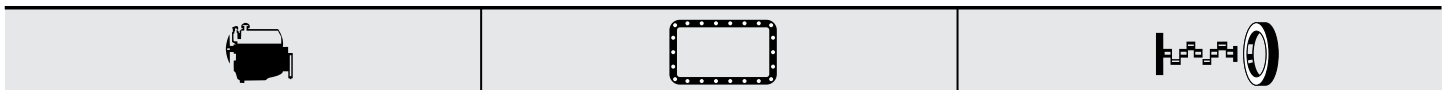
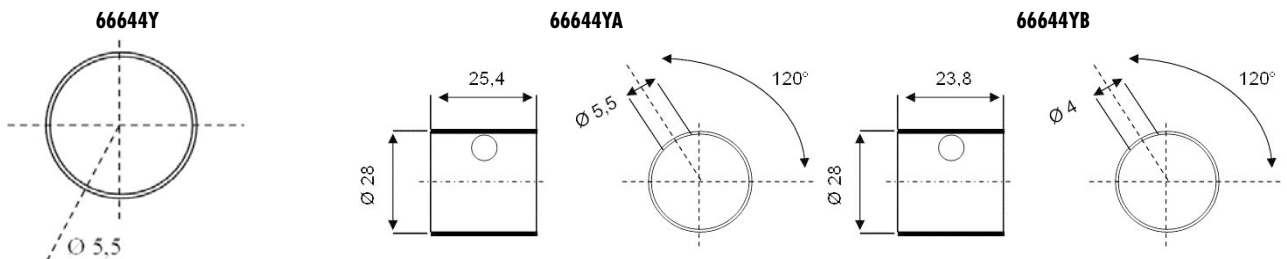
									
MB/HL 1,2,4,5	4	52.990/53.010	56.717/56.735	20.750	1.843	0.020/0.080	BS	4128CP	<b>H1084/5</b> STD 0.25 0.50
MB/HL 3	1	52.990/53.010	56.717/56.735	24.250	1.843	0.020/0.080	BS	4129CP	
TW/A	2	59.000/59.250	73.600/73.850		2.362		BS	62037AF	<b>A201/2</b> STD .005
SE/PB	1	25.004/25.010	26.939/26.972	25.400			BS	66644Y	<b>55-4190</b> SEMI
SE/PB	1	26.004/26.010	27.939/27.972	25.400			BS	66644YA	<b>55-4232</b> SEMI
SE/PB	1	25.500/25.640	27.939/27.972	23.800			BS	66644YB	<b>55-4233</b> SEMI







**JJ298**  
(Cork)

**NB742**  30.00x43.00x8.00mm, ACM  
**NB732**  74.00x90.00x10.00mm, FPM

**JJ298**

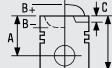
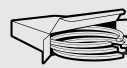
**1008**  **82.60 Diesel**



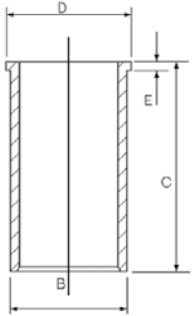





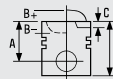

160 D100      4 Cyl.      20:1      1929cc      51kW (69)PS      TD10307      **317**



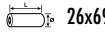

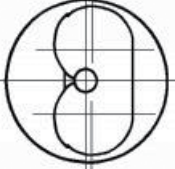



			
<b>87-783800-10</b> <b>87-783808-10</b>	<b>08-783800-00</b> <b>08-783808-00</b>	<b>14-021311-00 D</b> B 86.06 C 154.00 D 89.00 E 4.50	
STD 0.60mm	STD 0.60mm		
A 43.00 B+ 2.30 D 76.00  26x69	3.00 MOL P 2.00 P 3.00 CR P		
AK HA RT			



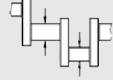
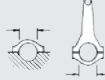

# FIAT GROUP

...Continued

## 1008



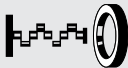

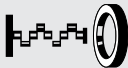
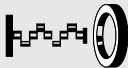

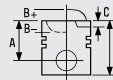

			
<b>87-783800-30</b> <b>87-783808-30</b> STD 0.60mm  A 42.40 B+ 2.50 D 76.00  26x69  HA RT	 	<b>08-783800-00</b> <b>08-783808-00</b> STD 0.60mm  3.00  MOL P 2.00  P 3.00  CR P	

									
BE/PL	4	50.782/50.802	53.897/53.913	19.500	1.537	0.021/0.082	AL-LF	66240RA	<b>01-4175/4</b> STD 0.25 0.50 0.75 1.00
MB/HL 1,2,4,5	4	52.985/53.005	56.717/56.730	20.750	1.841	0.030/0.088	AL-LF	66316RA	<b>H1043/5</b> STD 0.25 0.50 0.75
MB/HL 3	1	52.985/53.005	56.717/56.730	24.250	1.841	0.030/0.088	AL-LF	66317RA	
TW/A	2	59.000/59.250	73.600/73.850		2.362		BS	62037AF	<b>A201/2</b> STD .005
SE/PB	1	25.004/25.010	26.939/26.972	25.400			BS	66644Y	<b>55-4190</b> SEMI

		
	<b>JJ298</b> (Cork)  JJ298	<b>NB742</b>  30.00x43.00x8.00mm, ACM <b>NB732</b>  74.00x90.00x10.00mm, FPM

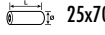
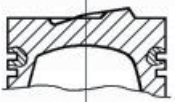
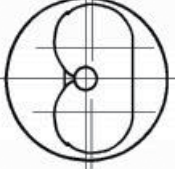

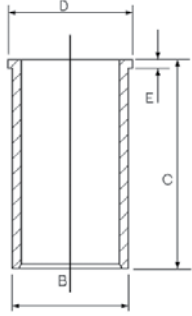

## 1009





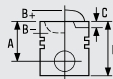

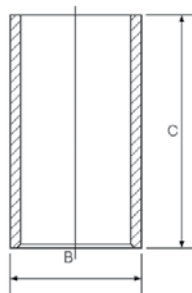

230 A2.000      4 Cyl.      20:1      1929cc      51kW (70)PS      TD862      318

			
<b>87-785400-00</b> <b>87-785408-00</b> STD 0.60mm  A 42.60 B+ 2.50 D 75.80  25x70  RT	 	<b>08-785400-00</b> <b>08-785408-00</b> STD 0.60mm eng. 690651 →  2.50  MOL P 2.00  P 3.00  CR P	<b>14-021311-00 D</b> B 86.06    C 154.00    D 89.00    E 4.50 <b>14-023560-00 D</b> B 86.00    C 154.00    D 89.00    E 4.50 <b>14-023751-00 D</b> B 87.00    C 154.00    D 89.00    E 4.55  

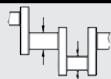
...Continued

**1009**  **82.60** Diesel

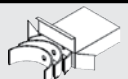

			
		<p><b>14-014730-00 D</b>  <b>B 86.09 C 154.00</b></p> 	

									
BE/PL	4	50.787/50.807	53.901/53.913	19.500	1.534	0.028/0.083	BS	4350CP	<b>71-4157/4</b> STD 0.25 0.50
MB/HL 1,2,4,5	4	52.985/53.005	56.717/56.730	20.750	1.841	0.030/0.088	AL-LF	66316RA	<b>H1043/5</b> STD 0.25 0.50 0.75
MB/HL 3	1	52.985/53.005	56.717/56.730	24.250	1.841	0.030/0.088	AL-LF	66317RA	
TW/A	2	59.000/59.250	73.600/73.850		2.362		BS	62037AF	<b>A201/2</b> STD .005
SE/PB	1	26.004/26.010	27.939/27.972	25.400			BS	66644YA	<b>55-4232</b> SEMI
SE/PB	1	25.500/25.640	27.939/27.972	23.800			BS	66644YB	<b>55-4233</b> SEMI

66644YA

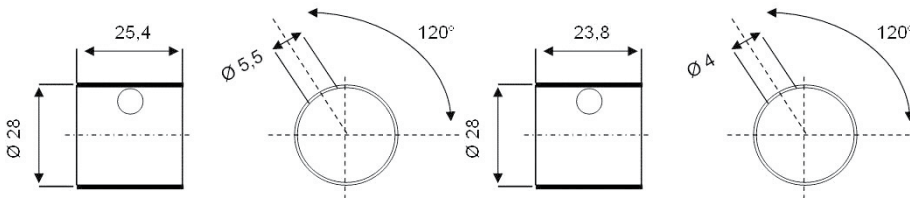
66644YB



		
---	---	---

EV684

JJ298  
(Cork)  
JJ398



JJ298



JJ398

**NB742** 30.00x43.00x8.00mm, ACM  
**NB732** 74.00x90.00x10.00mm, FPM

## 1010

### 82.60

### Diesel



<b>230 A3.000</b>	4 Cyl.	20:1	1929cc	<b>60kW (82)PS</b>	<b>Turbocharged</b>	<b>TD5481</b>	<b>319</b>
<b>230 A4.000 Euro 2</b>	4 Cyl.	19:1	1929cc	<b>59kW (80)PS</b>	<b>Turbocharged</b>	<b>TD4407</b>	<b>319</b>
<b>280 A1.000</b>	4 Cyl.	20:1	1929cc	<b>60kW (82)PS</b>	<b>Turbocharged</b>	<b>TD1043</b>	<b>320</b>

<p><b>87-783800-10</b> STD <b>87-783808-10</b> 0.60mm</p> <p>A 43.00 B+ 2.30 D 76.00 26x69</p> <p>AK HA RT</p>	<p><b>08-783800-00</b> STD <b>08-783808-00</b> 0.60mm</p> <p>3.00 MOL P 2.00 P 3.00 CR P</p>	<p><b>14-021311-00 D</b> B 86.06 C 154.00 D 89.00 E 4.50 <b>14-023560-00 D</b> B 86.00 C 154.00 D 89.00 E 4.50 <b>14-023751-00 D</b> B 87.00 C 154.00 D 89.00 E 4.55</p>	
<p><b>87-783800-30</b> STD <b>87-783808-30</b> 0.60mm</p> <p>A 42.40 B+ 2.50 D 76.00 26x69</p> <p>HA RT</p>	<p><b>08-783800-00</b> STD <b>08-783808-00</b> 0.60mm</p> <p>3.00 MOL P 2.00 P 3.00 CR P</p>	<p><b>14-014730-00 D</b> B 86.09 C 154.00</p>	
<p><b>08-141400-00</b> STD eng. →0675108</p> <p>3.00 MOL P 2.00 P 4.00 CR P</p>			

BE/PL	4	50.787/50.807	53.901/53.913	19.500	1.534	0.028/0.083	BS	4350CP	<b>71-4157/4</b> STD 0.25 0.50	
MB/HL 1,2,4,5	4	52.990/53.010	56.717/56.735	20.750	1.843	0.020/0.080	BS	4128CP	<b>H1084/5</b> STD 0.25 0.50	
MB/HL 3	1	52.990/53.010	56.717/56.735	24.250	1.843	0.020/0.080	BS	4129CP		
TW/A	2	59.000/59.250	73.600/73.850		2.362		BS	62037AF	<b>A201/2</b> STD .005	
SE/PB	1	26.004/26.010	27.939/27.972	25.400			BS	66644YA	<b>55-4232</b> SEMI	

<p><b>EV684</b></p>	<p><b>JJ298</b> (Cork) <b>JJ398</b></p> <p><b>JJ298</b>      <b>JJ398</b></p>	<p><b>NB742</b> 30.00x43.00x8.00mm, ACM <b>NB732</b> 74.00x90.00x10.00mm, FPM</p>

**1011**

**82.60**

**Diesel**



831 D1.000

4 Cyl.

20:1

1929cc

48-59kW (55-80)PS

Turbo Intercooled

TD4607

321

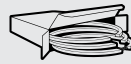
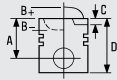

**08-783800-00** STD  
**08-783808-00** 0.60mm

3.00 MOL P  
 2.00 P  
 3.00 CR P



**14-021311-00 D**  
**B 86.06 C 154.00 D 89.00 E 4.50**  
**14-023751-00 D**  
**B 87.00 C 154.00 D 89.00 E 4.55**

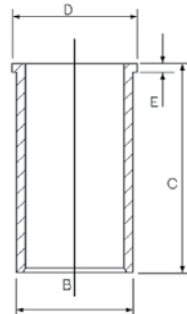

BE/PL	4	50.787/50.807	53.892/53.910	19.500	1.537	0.020/0.070	BS	1040CP	<b>71-4118/4</b> STD 0.25 0.50

→02/89

MB/HL 1,2,4,5	4	52.990/53.010	56.717/56.735	20.750	1.843	0.020/0.080	BS	4128CP	<b>H1084/5</b> STD 0.25 0.50
MB/HL 3	1	52.990/53.010	56.717/56.735	24.250	1.843	0.020/0.080	BS	4129CP	
TW/A	2	59.000/59.250	73.600/73.850		2.362		BS	62037AF	<b>A201/2</b> STD .005
SE/PB	1	25.004/25.010	26.939/26.972	25.400			BS	66644Y	<b>55-4190</b> SEMI
SE/PB	1	26.004/26.010	27.939/27.972	25.400			BS	66644YA	<b>55-4232</b> SEMI
SE/PB	1	25.500/25.640	27.939/27.972	23.800			BS	66644YB	<b>55-4233</b> SEMI

66644Y

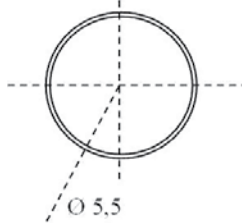

66644YA

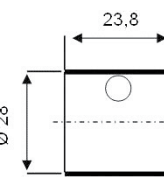
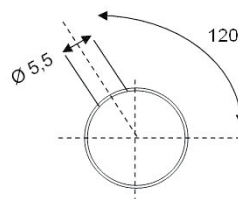
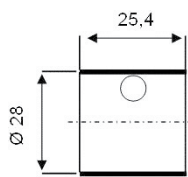

66644YB

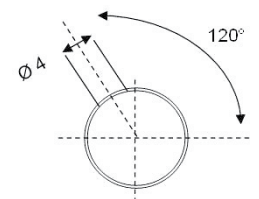

--	--	--

JJ298

(Cork)

JJ398



JJ298



JJ398

**NB742** 30.00x43.00x8.00mm, ACM

**NB732** 74.00x90.00x10.00mm, FPM

## 1012



82.60

Diesel



831 D1.000

4 Cyl.

1929cc

59kW (80)PS

Turbocharged

TD4410

322

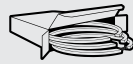
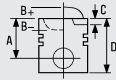

87-785400-00  
87-785408-00

STD  
0.60mm

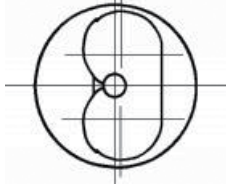
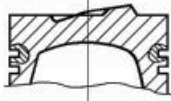

A 42.60  
B+ 2.50  
D 75.80  
25x70

RT

08-785400-00 STD  
08-785408-00 0.60mm  
eng. 690651 →

2.50 MOL P  
2.00 P  
3.00 CR P

14-021311-00 D  
B 86.06 C 154.00 D 89.00 E 4.50  
14-023560-00 D  
B 86.00 C 154.00 D 89.00 E 4.50  
14-023751-00 D  
B 87.00 C 154.00 D 89.00 E 4.55

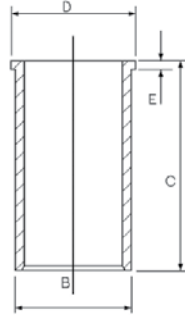

14-014730-00 D  
B 86.09 C 154.00

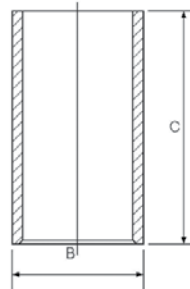

BE/PL	4	50.787/50.807	53.892/53.910	19.500	1.537	0.020/0.070	BS	1040CP	71-4118/4 STD 0.25 0.50
MB/HL 1,2,4,5	4	52.990/53.010	56.717/56.735	20.750	1.843	0.020/0.080	BS	4128CP	H1084/5 STD 0.25 0.50
MB/HL 3	1	52.990/53.010	56.717/56.735	24.250	1.843	0.020/0.080	BS	4129CP	
TW/A	2	59.000/59.250	73.600/73.850		2.362		BS	62037AF	A201/2 STD .005
SE/PB	1	25.004/25.010	26.939/26.972	25.400			BS	66644Y	55-4190 SEMI



JJ298  
(Cork)  
JJ398



JJ298



JJ398

NB742 30.00x43.00x8.00mm, ACM  
NB732 74.00x90.00x10.00mm, FPM

## 1013

## 82.60

## Diesel



<b>835 A4.000</b>	4 Cyl.	19.9:1	1929cc	<b>66kW (90)PS</b>	<b>Turbocharged</b>	<b>TD1846</b>	<b>323</b>
<b>835 A4.046</b>	4 Cyl.	20:1	1929cc	<b>66kW (90)PS</b>	<b>Turbocharged</b>	<b>TD5425</b>	<b>324</b>

<b>87-783800-30</b> <b>87-783808-30</b>  <b>STD</b> <b>0.60mm</b>  <b>A 42.40</b> <b>B+ 2.50</b> <b>D 76.00</b> <b>26x69</b>  <b>HA RT</b>	<b>08-783800-00</b> STD <b>08-783808-00</b> 0.60mm  <b>3.00</b> <b>MOL P</b> <b>2.00</b> <b>P</b> <b>3.00</b> <b>CR P</b>	<b>14-021311-00 D</b> <b>B 86.06 C 154.00 D 89.00 E 4.50</b> <b>14-023751-00 D</b> <b>B 87.00 C 154.00 D 89.00 E 4.55</b>  	

MB/HL 1,2,4,5	MB/HL 3	TW/A	SE/PB	SE/PB	SE/PB	66644Y	66644YA	66644YB	H1084/5 STD 0.25 0.50	A201/2 STD .005	55-4190 SEMI	55-4232 SEMI	55-4233 SEMI
4	1	2	1	1	1	52.990/53.010	56.717/56.735	20.750	1.843	0.020/0.080	BS	4128CP	
						52.990/53.010	56.717/56.735	24.250	1.843	0.020/0.080	BS	4129CP	
						59.000/59.250	73.600/73.850		2.362		BS	62037AF	
						25.004/25.010	26.939/26.972	25.400			BS	66644Y	
						26.004/26.010	27.939/27.972	25.400			BS	66644YA	
						25.500/25.640	27.939/27.972	23.800			BS	66644YB	

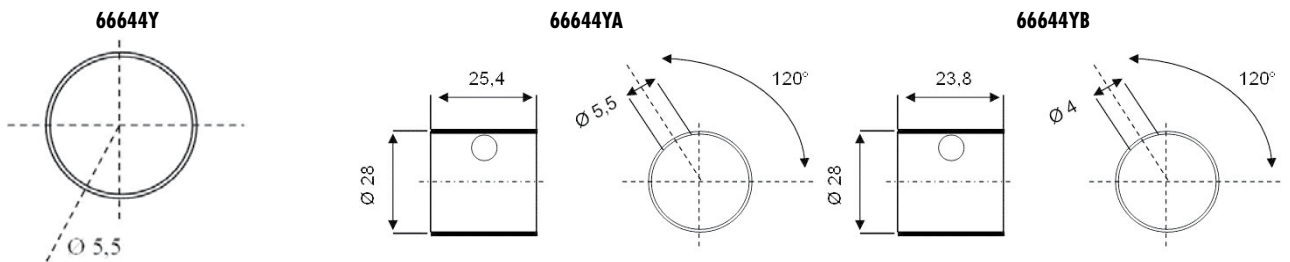

<b>JJ298</b> (Cork) <b>JJ398</b>	<b>JJ298</b>  <b>JJ398</b> 	<b>NB742</b> 30.00x43.00x8.00mm, ACM <b>NB732</b> 74.00x90.00x10.00mm, FPM





## 1014





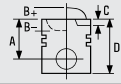
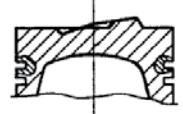
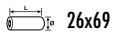

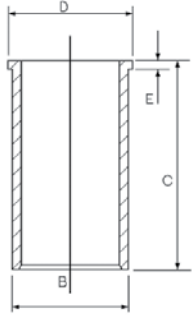
### 82.60

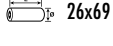

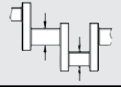
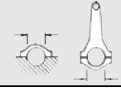

### Diesel

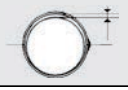

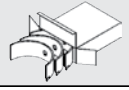









AR 33601	4 Cyl.	19.2:1	1929cc	66-68kW (90-92)PS	Turbo Intercooled	TD5069	325
AR 67501	4 Cyl.	19.2:1	1929cc	66-68kW (90-92)PS	Turbocharged	TD140	326



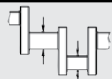





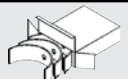

 <p><b>87-783800-10</b> <b>87-783808-10</b></p> <p>STD 0.60mm</p>  <p>A 43.00 B+ 2.30 D 76.00</p>  <p>26x69</p> <p>AK HA RT</p>	 <p><b>08-783800-00</b> <b>08-783808-00</b></p> <p>STD 0.60mm</p> <p>3.00 MOL P 2.00 P 3.00 CR P</p>	 <p><b>14-021311-00 D</b> B 86.06 C 154.00 D 89.00 E 4.50</p> 	
<p><b>87-783800-30</b> <b>87-783808-30</b></p> <p>STD 0.60mm</p>  <p>A 42.40 B+ 2.50 D 76.00</p>  <p>26x69</p> <p>HA RT</p>	<p><b>08-783800-00</b> <b>08-783808-00</b></p> <p>STD 0.60mm</p> <p>3.00 MOL P 2.00 P 3.00 CR P</p>		



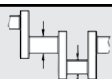
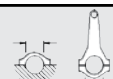

									
BE/PL	4	50.787/50.807	53.901/53.913	19.500	1.534	0.028/0.083	BS	4350CP	<b>71-4157/4</b> STD 0.25 0.50
MB/HL 1,2,4,5	4	52.990/53.010	56.717/56.735	20.750	1.843	0.020/0.080	BS	4128CP	<b>H1084/5</b> STD 0.25 0.50
MB/HL 3	1	52.990/53.010	56.717/56.735	24.250	1.843	0.020/0.080	BS	4129CP	
TW/A	2	59.000/59.250	73.600/73.850		2.362		BS	62037AF	<b>A201/2</b> STD .005
SE/PB	1	26.004/26.010	27.939/27.972	25.400			BS	66644YA	<b>55-4232</b> SEMI



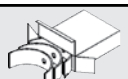





		
<p><b>EV684</b></p>	<p><b>JJ298</b> (Cork)</p>  <p><b>JJ298</b></p>	<p><b>NB742</b> 30.00x43.00x8.00mm, ACM <b>NB732</b> 74.00x90.00x10.00mm, FPM</p>

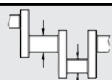
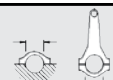

<b>1015</b>  <b>82.60 Diesel</b> 									
<b>AR 67502</b> 4 Cyl.      19.2:1      1929cc <b>66-68kW (90-92)PS</b> <b>Turbo Intercooled</b> <b>TD21140</b>									
									
BE/PL	4	50.787/50.807	53.901/53.913	19.500	1.534	0.028/0.083	BS	4350CP	<b>71-4157/4</b> STD 0.25 0.50
MB/HL 1,2,4,5	4	52.990/53.010	56.717/56.735	20.750	1.843	0.020/0.080	BS	4128CP	<b>H1084/5</b> STD 0.25 0.50
MB/HL 3	1	52.990/53.010	56.717/56.735	24.250	1.843	0.020/0.080	BS	4129CP	
TW/A	2	59.000/59.250	73.600/73.850		2.362		BS	62037AF	<b>A201/2</b> STD .005
SE/PB	1	26.004/26.010	27.939/27.972	25.400			BS	66644YA	<b>55-4232</b> SEMI

<b>1016</b>  <b>83.00 Diesel</b> 									
<b>138 A5.000</b> 4 Cyl.      20:1      1714cc <b>40-43kW (55-58)PS</b> <b>TD4358</b> <b>327</b>									
									
BE/PL	4	50.782/50.802	53.897/53.913	19.500	1.537	0.021/0.082	AL-LF	66240RA	<b>01-4175/4</b> STD 0.25 0.50 0.75 1.00
MB/HL 1,2,4,5	4	52.985/53.005	56.717/56.730	20.750	1.841	0.030/0.088	AL-LF	66316RA	<b>H1043/5</b> STD 0.25 0.50 0.75
MB/HL 3	1	52.985/53.005	56.717/56.730	24.250	1.841	0.030/0.088	AL-LF	66317RA	
TW/A	2	59.000/59.250	73.600/73.850		2.362		BS	62037AF	<b>A201/2</b> STD .005
SE/PB	1	25.004/25.010	26.939/26.972	25.400			BS	66644Y	<b>55-4190</b> SEMI

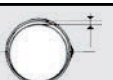
		
JJ136		
		
JJ136		

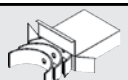
<b>1017</b>  <b>83.00 Diesel</b> 									
<b>138 B5.000</b> 4 Cyl.      20:1      1714cc <b>40-43kW (54-58)PS</b> <b>TD23462</b>									
									
BE/PL	4	50.782/50.802	53.897/53.913	19.500	1.537	0.021/0.082	AL-LF	66240RA	<b>01-4175/4</b> STD 0.25 0.50 0.75 1.00
MB/HL 1,2,4,5	4	52.985/53.005	56.717/56.730	20.750	1.841	0.030/0.088	AL-LF	66316RA	<b>H1043/5</b> STD 0.25 0.50 0.75
MB/HL 3	1	52.985/53.005	56.717/56.730	24.250	1.841	0.030/0.088	AL-LF	66317RA	
TW/A	2	59.000/59.250	73.600/73.850		2.362		BS	62037AF	<b>A201/2</b> STD .005
SE/PB	1	25.004/25.010	26.939/26.972	25.400			BS	66644Y	<b>55-4190</b> SEMI

# FIAT GROUP

## 1018

83.00

**Diesel**



138 B6.000

4 Cyl.

20.5:1

1714cc

43kW (58)PS

TD922

328

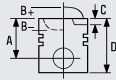

87-215100-10  
87-215108-10

STD  
0.60mm

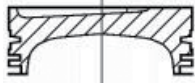

08-215100-10  
08-215108-10  
08-215110-10

STD  
0.60mm  
0.80mm

14-014720-00 D  
B 86.00 C 150.50

A 45.90  
B- 2.80  
D 85.00  
 25x71

RT

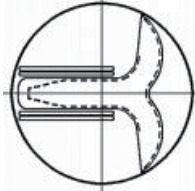

2.50 MOL P  
2.00 P  
4.00 CR P

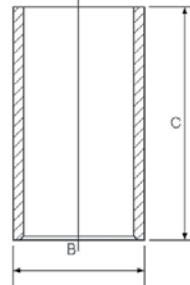

BE/PL	4	50.782/50.802	53.897/53.913	19.500	1.537	0.021/0.082	AL-LF	66240RA	<b>01-4175/4</b> STD 0.25 0.50 0.75 1.00
MB/HL 1,2,4,5	4	52.985/53.005	56.717/56.730	20.750	1.841	0.030/0.088	AL-LF	66316RA	<b>H1043/5</b> STD 0.25 0.50 0.75
MB/HL 3	1	52.985/53.005	56.717/56.730	24.250	1.841	0.030/0.088	AL-LF	66317RA	
TW/A	2	59.000/59.250	73.600/73.850		2.362		BS	62037AF	<b>A201/2</b> STD .005
SE/PB	1	25.004/25.010	26.939/26.972	25.400			BS	66644Y	<b>55-4190</b> SEMI

	JJ136	<b>NB818</b> 40.00x56.00x7.00mm, ACM <b>NB732</b> 74.00x90.00x10.00mm, FPM
		JJ136

## 1019

83.00

**Petrol**



939 B1.000

4 Cyl.

9.5:1

1742cc

147kW (200)PS

Turbocharged

TD22716

329

939 B1.000

4 Cyl.

9.5:1

1742cc

147kW (200)PS

Turbocharged

TD24691

329

BE/PL	4	48.226/48.244	51.354/51.366	19.100	1.540	0.030/0.056	EC-LF	71-4776	<b>71-4776/4</b> STD [23]
MB/HL 1-5	5		56.705/56.718	20.750	1.861		AL-LF	02-4777	<b>H1293/5</b> STD
TW/A	2	59.000/59.260	73.600/73.850		2.485		AL-LF	04-4778	<b>A291/2</b> STD
SE/PB	1	26.000	28.939/28.972	22.100			BS-LF	55-4779	<b>55-4779</b> SEMI

		<b>NA5070</b> 31.00x41.00x7.00mm, FPM <b>NF888</b> 93.00x172.00x12.00mm, FPM

<b>1020</b>	<b>83.00</b>	<b>Petrol</b>					
<b>940 A1.000</b>	4 Cyl.	9.25:1	1742cc	<b>173-177kW (235-241)PS</b>	<b>Turbo Intercooled</b>	<b>TD23922</b>	<b>329</b>
		<div style="display: flex; justify-content: space-between;"> <div style="width: 45%;"> </div> <div style="width: 50%;"> <p><b>NA5070</b>  31.00x41.00x7.00mm, FPM</p> <p><b>NF888</b>  93.00x172.00x12.00mm, FPM</p> </div> </div>					

<b>1021</b>	<b>83.00</b>	<b>Petrol</b>				
<b>LFW</b>	4 Cyl.	9.5:1	1761cc	<b>73kW (99)PS</b>	<b>TD10167</b>	<b>330</b>
		<div style="display: flex; justify-content: space-between;"> <div style="width: 45%;"> </div> <div style="width: 50%;"> <p><b>08-323400-00</b> STD</p> <p>1.50  P PS</p> <p>1.50  P</p> <p>3.00  CR P</p> </div> </div>				

BE/PL	4	44.975/44.991	48.655/48.671	22.500	1.825	0.020/0.070	AL	4300RA	<b>01-4155/4</b> STD 0.30
MB/HL	5	59.990/60.000	63.718/63.727	20.290	1.845	0.028/0.072	AL-LF	66721RA	<b>H1074/5</b> STD 0.30
MB/HL	5	59.990/60.000	63.718/63.727	20.290	1.845	0.028/0.072	AL-LF	66722RA	
TW/A	4	67.050/67.300	83.050/83.300		2.330		BS	66721BF	<b>A214/4</b> STD 0.10

		<div style="display: flex; justify-content: space-between;"> <div style="width: 45%;"> <p><b>EL650</b></p> <p><b>JJ283</b> [20] <b>—PB907</b> 14.00x21.00x2.000mm</p> <p><b>JJ283</b></p> </div> <div style="width: 50%;"> <p><b>NA5191</b>  42.00x62.00x7.00mm, PTFE</p> <p><b>NA5192</b>  90.00x110.00x7.00mm, PTFE</p> </div> </div>					
--	--	---	--	--	--	--	--

[20] Oil Pan Material: Steel

[20] Matériel pour carter d'huile: acier

[20] Materiale coppa olio: Acciaio

[20] Material cárter: Acero

<b>1022</b>	<b>83.00</b>	<b>Diesel</b>				
<b>D8B</b>	4 Cyl.	1905cc	<b>68kW (92)PS</b>	<b>Turbocharged</b>	<b>TD6828</b>	<b>331</b>
		<div style="display: flex; justify-content: space-between;"> <div style="width: 45%;"> </div> <div style="width: 50%;"> <p><b>14-020530-00 D</b></p> <p><b>B 85.60 C 153.50 D 88.50 E 3.90</b></p> </div> </div>				

**87-105500-00**

STD

**87-105507-00**

0.50mm

**A** 46.75

**B-** 3.50

**D** 75.00

28x68

**AK HA RT TP**

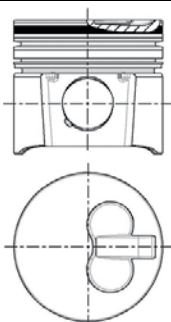

**08-105500-00**

STD

**08-105507-00**

0.50mm

**08-105510-00**

0.80mm

01/97 →

3.00



CK

2.00









NT



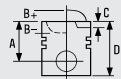



3.00

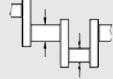
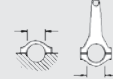

CR P

**1022**  **83.00 Diesel**

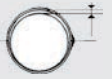
			
	<b>08-325500-00</b> STD <b>08-325507-00</b> 0.50mm →12/96  3.50  MOL P 2.00  P 3.00  CR P		

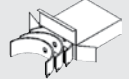



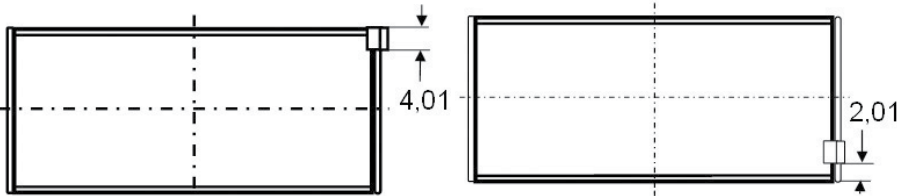

									
BE/PL	4	49.984/50.000	53.695/53.708	20.000	1.838	0.039/0.073	EC	71-3730	<b>71-3730/4</b> STD 0.30
BE/PL	4	49.984/50.000	53.695/53.708	20.000	1.838	0.020/0.073	EC	71-3899	<b>71-3899/4</b> STD 0.30

71-3730

71-3899

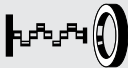





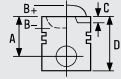

MB/HL 1-5	5	59.981/60.000	63.731/63.750	20.290	1.845	0.040/0.100	AL-LF	66726RA	<b>H1057/5</b> STD 0.30 0.50
TW/A	4	67.050/67.300	83.050/83.300		1.880		AL-LF	4141AF	<b>A188/4</b> STD
SE/PB	1	28.007/28.020	30.200/30.221	23.100			BS	41450.500	<b>55-4499</b> SEMI

		
 <b>EL890</b>	<b>JJ283</b> [20] 	<b>NA5191</b>  42.00x62.00x7.00mm, PTFE <b>NA5192</b>  90.00x110.00x7.00mm, PTFE
[20] Oil Pan Material: Steel	[20] Matériel pour carter d'huile: acier	[20] Materiale coppa olio: Acciaio







**1023**  **83.00 Diesel**



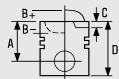
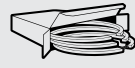





<b>D8B (XUD9TE)</b>	4 Cyl.	21.8:1	1905cc	<b>66-69kW (90-94)PS</b>	<b>Turbo Intercooled</b>	<b>TD21263</b>	<b>332</b>
<b>DHX (XUD9TE)</b>	4 Cyl.	21.8:1	1905cc	<b>66-69kW (90-94)PS</b>	<b>Turbo Intercooled</b>	<b>TD21264</b>	<b>335</b>

			
	<b>08-105500-00</b> STD <b>08-105507-00</b> 0.50mm <b>08-105510-00</b> 0.80mm 01/97→  3.00  CK 2.00  NT 3.00  CR P		

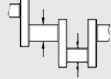
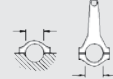
...Continued

**1023**  **83.00** Diesel

			
	<b>08-325500-00</b> STD <b>08-325507-00</b> 0.50mm →12/96  3.50  MOL P 2.00  P 3.00  CR P		

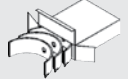
									
BE/PL	4	49.984/50.000	53.695/53.708	20.000	1.838	0.039/0.073	EC	71-3730	<b>71-3730/4</b> STD 0.30
BE/PL	4	49.984/50.000	53.695/53.708	20.000	1.838	0.020/0.073	EC	71-3899	<b>71-3899/4</b> STD 0.30

71-3730



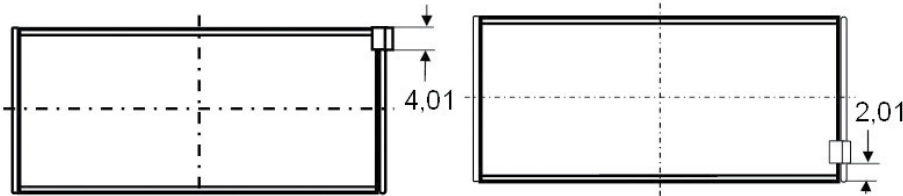





71-3899

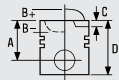
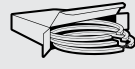



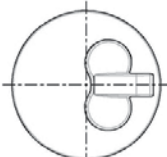



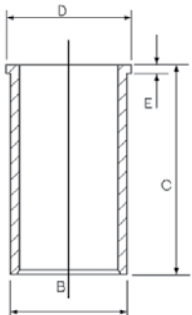

MB/HL 1-5	5	59.981/60.000	63.731/63.750	20.290	1.845	0.040/0.100	AL-LF	66726RA	<b>H1057/5</b> STD 0.30 0.50
TW/A	4	67.050/67.300	83.050/83.300		1.880		AL-LF	4141AF	<b>A188/4</b> STD
SE/PB	1	28.007/28.020	30.200/30.221	23.100			BS	41450.500	<b>55-4499</b> SEMI

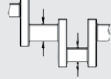
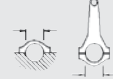





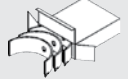

**1024**  **83.00** Diesel 

D9B 4 Cyl. 1905cc 50-51kW (68-69)PS TD6827 333

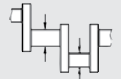
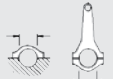
			
<b>87-152000-10</b> STD <b>87-152007-10</b> 0.50mm <b>87-152010-10</b> 0.80mm  A 46.80 B- 2.20 D 84.30  25x72	  	<b>08-152000-00</b> STD <b>08-152003-00</b> 0.125mm <b>08-152007-00</b> 0.50mm <b>08-152010-00</b> 0.80mm <b>8-152011-00</b> 1.00mm  2.00  CR P 2.00  P 3.00  CR P	<b>14-020530-00 D</b> B 85.60 C 153.50 D 88.50 E 3.90  

									
BE/PL	4	49.984/50.000	53.695/53.708	20.050	1.830	0.040/0.090	AL-LF	66725RA	<b>01-4200/4</b> STD 0.30 0.50
MB/HL 1-5	5	59.981/60.000	63.731/63.750	20.290	1.845	0.040/0.100	AL-LF	66726RA	<b>H1057/5</b> STD 0.30 0.50

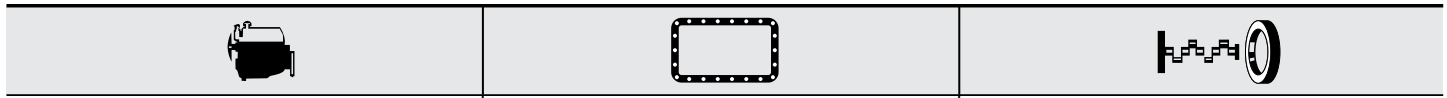

**1024**  **83.00** **Diesel**

									
TW/A	4	67.050/67.300	83.050/83.300		2.330		BS	667218F	<b>A214/4</b> STD 0.10
SE/PB	1	25.007/25.020	27.200/27.221	24.050			BS	66729YA	<b>55-4201</b> SEMI



**EL890**

**JJ283** [20]  
=PA349  
22.00x16.00x2.000mm

**NA5191**  42.00x62.00x7.00mm, PTFE  
**NA5192**  90.00x110.00x7.00mm, PTFE



**JJ283**

[20] Oil Pan Material: Steel







[20] Matériel pour carter d'huile: acier



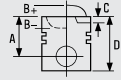



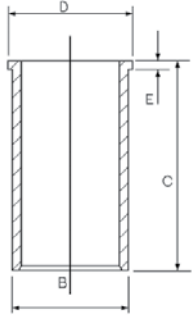

[20] Materiale coppa olio: Acciaio

[20] Material cárter: Acero

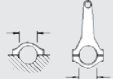
**1025**  **83.00** **Diesel** 

**D9B (XUD9A)** 4 Cyl. 23:1 1905cc **47-52kW (64-71)PS** **TD21265** **334**

			
	<p><b>08-152000-00</b> STD</p> <p><b>08-152003-00</b> 0.125mm</p> <p><b>08-152007-00</b> 0.50mm</p> <p><b>08-152010-00</b> 0.80mm</p> <p><b>08-152011-00</b> 1.00mm</p> <p>2.00  CR P</p> <p>2.00  P</p> <p>3.00  CR P</p>	<p><b>14-020530-00 D</b></p> <p><b>B 85.60 C 153.50 D 88.50 E 3.90</b></p> 	

									
BE/PL	4	49.984/50.000	53.695/53.708	20.050	1.830	0.040/0.090	AL-LF	66725RA	<b>01-4200/4</b> STD 0.30 0.50
MB/HL 1-5	5	59.981/60.000	63.731/63.750	20.290	1.845	0.040/0.100	AL-LF	66726RA	<b>H1057/5</b> STD 0.30 0.50
TW/A	4	67.050/67.300	83.050/83.300		1.880		AL-LF	4141AF	<b>A188/4</b> STD
SE/PB	1	25.007/25.020	27.200/27.221	24.050			BS	66729YA	<b>55-4201</b> SEMI

...Continued

**1025**  **83.00** **Diesel**

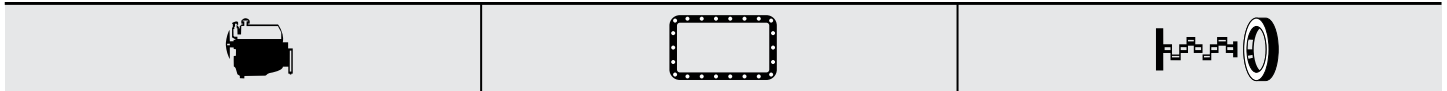

**EL890** **JJ283** [20] **NA5191**  42.00x62.00x7.00mm, PTFE  
**PA349** 22.00x16.00x2.00mm **NA5192**  90.00x110.00x7.00mm, PTFE



**JJ283**

[20] Oil Pan Material: Steel









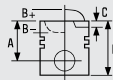

[20] Matériel pour carter d'huile: acier





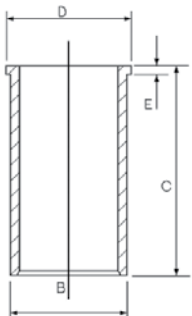
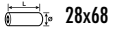



[20] Materiale coppa olio: Acciaio

[20] Material cárter: Acero

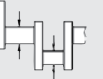
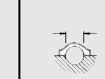
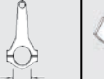
**1026**  **83.00** **Diesel** 

**DHX (XUD9TF/L)** 4 Cyl. 21.8:1 1905cc **66-68kW (90-92)PS** **Turbo Intercooled** **TD4352** **336**

			
<b>87-105500-00</b> STD <b>87-105507-00</b> 0.50mm	<b>08-105500-00</b> STD <b>08-105507-00</b> 0.50mm <b>08-105510-00</b> 0.80mm 01/97 →  3.00  CK 2.00  NT 3.00  CR P	<b>14-020530-00 D</b> <b>B 85.60 C 153.50 D 88.50 E 3.90</b> 	
<b>A</b> 46.75 <b>B-</b> 3.50 <b>D</b> 75.00  28x68  <b>AK HA RT TP</b>	<b>08-325500-00</b> STD <b>08-325507-00</b> 0.50mm →12/96  3.50  MOL P 2.00  P 3.00  CR P		

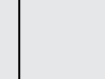
										
BE/PL 4 49.984/50.000 53.695/53.708 20.000 1.838 0.039/0.073 EC 71-3730 <b>71-3730/4</b> STD 0.30	BE/PL 4 49.984/50.000 53.695/53.708 20.000 1.838 0.020/0.073 EC 71-3899 <b>71-3899/4</b> STD 0.30									

**71-3730**

**71-3899**

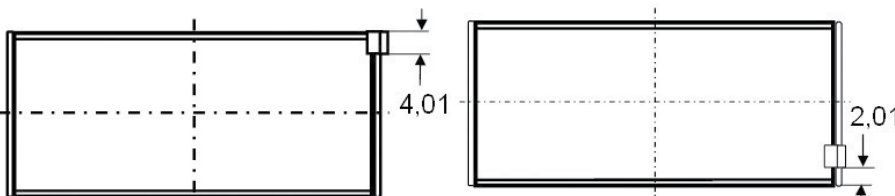

MB/HL 1-5 5 59.981/60.000 63.731/63.750 20.290 1.845 0.040/0.100 AL-LF 66726RA <b>H1057/5</b> STD 0.30 0.50	TW/A 4 67.050/67.300 83.050/83.300 1.880 AL-LF 4141AF <b>A188/4</b> STD	SE/PB 1 28.007/28.020 30.200/30.221 23.100 BS 41450.500 <b>55-4499</b> SEMI
---	---	---

# FIAT GROUP

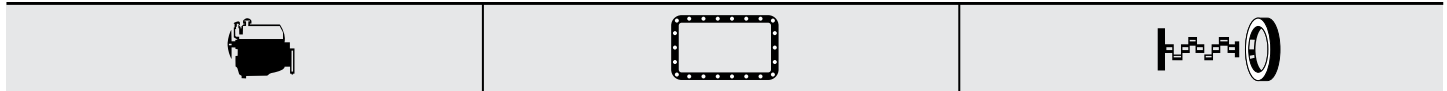

...Continued

## 1026 83.00 Diesel

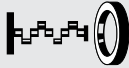

EL890

JJ283 [20]  
=PB907  
14.00x21.00x2.000mm

NA5191  42.00x62.00x7.00mm, PTFE  
NA5192  90.00x110.00x7.00mm, PTFE



JJ283

[20] Oil Pan Material: Steel

[20] Matériel pour carter d'huile: acier

[20] Materiale coppa olio: Acciaio

[20] Material cárter: Acero

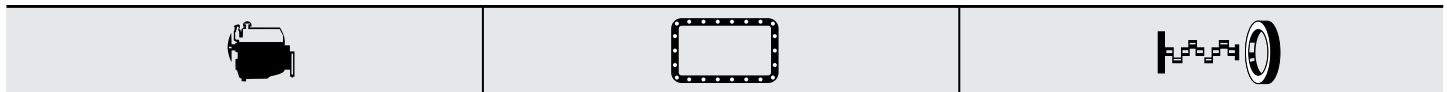

## 1027 83.00 Diesel

DHX 4 Cyl. 21.8:1 1905cc 59kW (80)PS Turbo Intercooled TD24799 337



EL890

JJ283 [20]  
=PB907  
14.00x21.00x2.000mm

NA5191  42.00x62.00x7.00mm, PTFE  
NA5192  90.00x110.00x7.00mm, PTFE



JJ283

[20] Oil Pan Material: Steel

[20] Matériel pour carter d'huile: acier

[20] Materiale coppa olio: Acciaio

[20] Material cárter: Acero

## 1028 83.00 Diesel

DJY (XUD9) 4 Cyl. 23.5:1 1905cc 50-52kW (68-71)PS TD21267 338

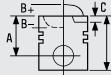
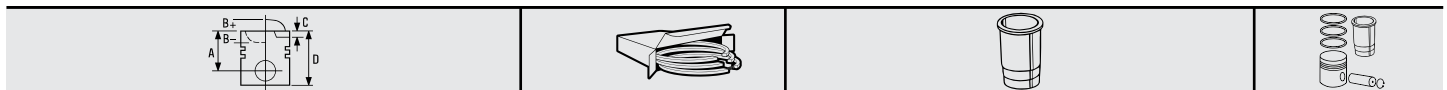

08-152000-00 STD  
08-152003-00 0.125mm  
08-152007-00 0.50mm  
08-152010-00 0.80mm  
08-152011-00 1.00mm

2.00  CR P  
2.00  P  
3.00  CR P



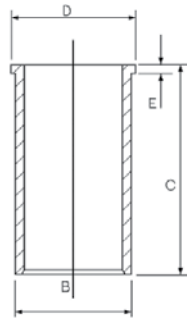



14-020530-00 D  
B 85.60 C 153.50 D 88.50 E 3.90













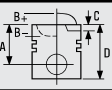
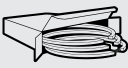



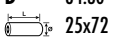
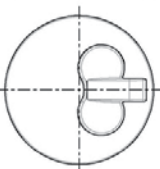

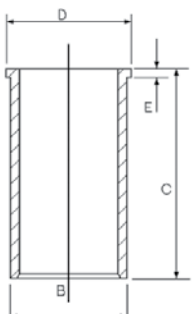

BE/PL	4	49.984/50.000	53.695/53.708	20.050	1.830	0.040/0.090	AL-LF	66725RA	01-4200/4 STD 0.30 0.50
MB/HL 1-5	5	59.981/60.000	63.731/63.750	20.290	1.845	0.040/0.100	AL-LF	66726RA	H1057/5 STD 0.30 0.50
TW/A	4	67.050/67.300	83.050/83.300		1.880		AL-LF	4141AF	A188/4 STD
SE/PB	1	25.007/25.020	27.200/27.221	24.050			BS	66729YA	55-4201 SEMI



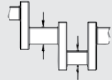
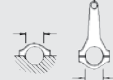



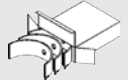

...Continued



<b>1028</b>  <b>83.00</b> <b>Diesel</b>			
			
<b>EL890</b>	<b>JJ283</b> [20]	<b>NA5191</b>  42.00x62.00x7.00mm, PTFE <b>NA5192</b>  90.00x110.00x7.00mm, PTFE	
			
	<b>JJ283</b>		
[20] Oil Pan Material: Steel	[20] Matériel pour carter d'huile: acier	[20] Materiale coppa olio: Acciaio	[20] Material cárter: Acero









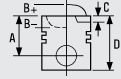

<b>1029</b>  <b>83.00</b> <b>Diesel</b>					
<b>DJY</b>	4 Cyl.	23.5:1	1905cc	<b>50kW (68)PS</b>	<b>TD12748</b> <b>339</b>
					
<b>87-152000-10</b> <b>87-152007-10</b> <b>87-152010-10</b>	STD 0.50mm 0.80mm		<b>08-152000-00</b> STD <b>08-152003-00</b> 0.125mm <b>08-152007-00</b> 0.50mm <b>08-152010-00</b> 0.80mm <b>08-152011-00</b> 1.00mm	<b>14-020530-00 D</b> B 85.60 C 153.50 D 88.50 E 3.90	<b>88-152000-30</b> 87-152000-10 + 14-020530-00
A 46.80 B- 2.20 D 84.30  25x72			2.00  CR P 2.00  P 3.00  CR P		



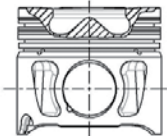
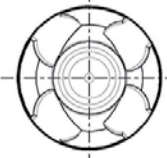





									
BE/PL	4	49.984/50.000	53.695/53.708	20.050	1.830	0.040/0.090	AL-LF	66725RA	<b>01-4200/4</b> STD 0.30 0.50
MB/HL 1-5	5	59.981/60.000	63.731/63.750	20.290	1.845	0.040/0.100	AL-LF	66726RA	<b>H1057/5</b> STD 0.30 0.50
TW/A	4	67.050/67.300	83.050/83.300		1.880		AL-LF	4141AF	<b>A188/4</b> STD
SE/PB	1	25.007/25.020	27.200/27.221	24.050			BS	66729YA	<b>55-4201</b> SEMI



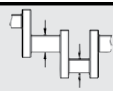

															
<b>EL890</b>				<b>JJ283</b> [20]				<b>NA5191</b>  42.00x62.00x7.00mm, PTFE <b>NA5192</b>  90.00x110.00x7.00mm, PTFE							
															
				<b>JJ283</b>											
[20] Oil Pan Material: Steel				[20] Matériel pour carter d'huile: acier				[20] Materiale coppa olio: Acciaio				[20] Material cárter: Acero			

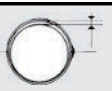

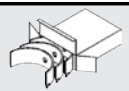
# FIAT GROUP



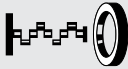



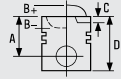
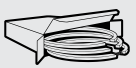

<b>1030</b>	 <b>83.00</b>	<b>Diesel</b>					
198 A5.000	4 Cyl.	16.1:1	1956cc	121kW (165)PS	Turbo Intercooled	TD21043	341
198 A5.000	4 Cyl.	16.5:1	1956cc	121kW (165)PS	Turbocharged	TD24569	341
940 A4.000	4 Cyl.	16.5:1	1956cc	125kW (170)PS	Turbo Intercooled	TD23924	341

							
87-436500-00	STD	  <b>08344A406</b>	08-436500-00	STD	  	 	
87-436506-00	0.40mm		08-436506-00	0.40mm			
A	43.63		1.50				
B-	15.80		1.50				
BØ	43.50		2.00				
D	72.63						
							

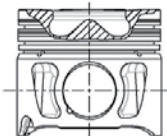
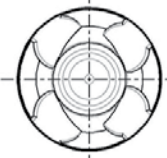







									
BE/PL	1	50.787/50.805	53.901/53.913	19.500	1.534	0.030/0.080	EC-LF	71-4780	71-4780 [23] STD
MB/HL	1	59.986/60.000	63.705/63.718	20.750	1.844	0.031/0.080	EC	72-3995	72-3995 STD 0.25 0.50
TW/A	2	67.785/68.040	82.425/82.677		2.485		AL-LF	4356AF	A191/2 STD
SE/PB	1		28.939/28.972	21.700			BS	4369Y	55-4159 SEMI

		
HR397	NA5070  31.00x41.00x7.00mm, FPM	NF888  93.00x172.00x12.00mm, FPM

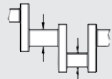
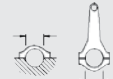





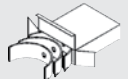

<b>1031</b>	 <b>83.00</b>	<b>Diesel</b>					
198 A5.000	4 Cyl.	16.5:1	1956cc	121kW (165)PS	Turbo Intercooled	TD24647	340

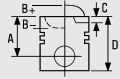
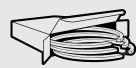



							
87-436500-00	STD	  <b>08344A406</b>	08-436500-00	STD	  	 	
87-436506-00	0.40mm		08-436506-00	0.40mm			
A	43.63		1.50				
B-	15.80		1.50				
BØ	43.50		2.00				
D	72.63						
							





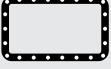

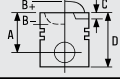
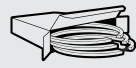

...Continued

<b>1031</b>		 <b>83.00</b>	<b>Diesel</b>								
											
BE/PL	1	50.787/50.805	53.901/53.913	19.500	1.534	0.030/0.080	EC-LF	71-4780	<b>71-4780</b> STD	[23]	
MB/HL	1	59.986/60.000	63.705/63.718	20.750	1.844	0.031/0.080	EC	72-3995	<b>72-3995</b> STD 0.25 0.50		
TW/A	2	67.785/68.040	82.425/82.677		2.485		AL-LF	4356AF	<b>A191/2</b> STD		
SE/PB	1		28.939/28.972	21.700			BS	4369Y	<b>55-4159</b> SEMI		

<b>1032</b>		 <b>83.00</b>	<b>Diesel</b>								
<b>198 A8.000</b>	4 Cyl.	16.5:1	1956cc	<b>121kW</b> (165)PS	<b>Turbo Intercooled</b>	<b>TD25650</b>	<b>341</b>				
<b>250 A1.000 Euro 5</b>	4 Cyl.	16.5:1	1956cc	<b>85kW</b> (116)PS	<b>Turbo Intercooled</b>	<b>TD25173</b>	<b>340</b>				
<b>263 A1.000 Euro 5</b>	4 Cyl.	16.5:1	1956cc	<b>99kW</b> (135)PS	<b>Turbo Intercooled</b>	<b>TD24764</b>	<b>341</b>				
<b>939 B3.000</b>	4 Cyl.		1956cc	<b>125kW</b> (170)PS	<b>Turbo Intercooled</b>	<b>TD23107</b>	<b>341</b>				
<b>D20AA Euro 5</b>	4 Cyl.	16.5:1	1956cc	<b>99kW</b> (135)PS	<b>Turbocharged</b>	<b>TD24670</b>	<b>340</b>				

			
	<b>08-436500-00</b> STD <b>08-436506-00</b> 0.40mm  1.50  GDC P 1.50  P 2.00  CK P		
	 		

		
	HR397	<b>NA5070</b>  31.00x41.00x7.00mm, FPM <b>NF888</b>  93.00x172.00x12.00mm, FPM

<b>1033</b>		 <b>83.00</b>	<b>Diesel</b>								
<b>198 A9.000</b>	4 Cyl.	16.5:1	1956cc	<b>120kW</b> (163)PS	<b>Turbo Intercooled</b>	<b>TD25651</b>					
											
	<b>08-436500-00</b> STD <b>08-436506-00</b> 0.40mm  1.50  GDC P 1.50  P 2.00  CK P										
	 										

## 1034

**83.00**
**Diesel**

<b>844 A2.000</b>	4 Cyl.	16.5:1	1956cc	<b>120kW (163)PS</b>	<b>Turbocharged</b>	<b>TD24593</b>	<b>342</b>
<b>844 A2.000</b>	4 Cyl.	16.5:1	1956cc	<b>120kW (163)PS</b>	<b>Turbocharged</b>	<b>TD24594</b>	
<b>844 A2.000</b>	4 Cyl.	16.5:1	1956cc	<b>120kW (163)PS</b>	<b>Turbocharged</b>	<b>TD24652</b>	



<b>87-436500-00</b> <b>87-436506-00</b>  <b>A</b> 43.63 <b>B-</b> 15.80 <b>BØ</b> 43.50 <b>D</b> 72.63 30x66	STD 0.40mm  	<b>08-436500-00</b> STD <b>08-436506-00</b> 0.40mm  1.50  GDC P 1.50  P 2.00  CK P  	
<b>08344A406</b>			

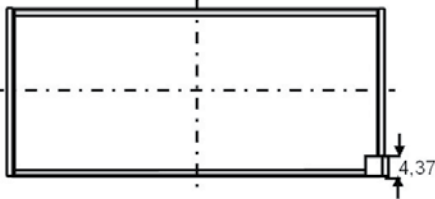







										[22]
BE/PL	1	50.787/50.805	53.901/53.913	19.500	1.534	0.030/0.080	EC	71-3994	<b>71-3994</b> STD 0.25	[22]
BE/PL	1	50.787/50.805	53.901/53.913	19.500	1.534	0.030/0.080	EC-LF	71-4780	<b>71-4780</b> STD	[23]

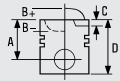
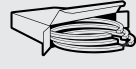

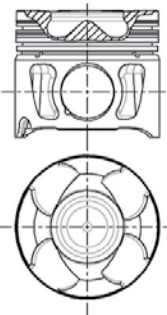

**71-3994**



MB/HL	1	59.986/60.000	63.705/63.718	20.750	1.844	0.031/0.080	EC	72-3995	<b>72-3995</b> STD 0.25 0.50
TW/A	2	67.785/68.040	82.425/82.677		2.485		AL-LF	4356AF	<b>A191/2</b> STD
SE/PB	1		28.939/28.972	21.700			BS	4369Y	<b>55-4159</b> SEMI

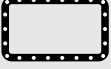







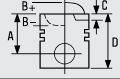

<b>HR397</b>		<b>NA5070</b> 31.00x41.00x7.00mm, FPM <b>NF888</b> 93.00x172.00x12.00mm, FPM



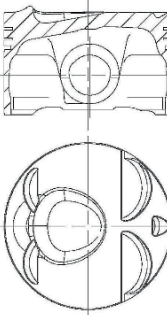



<b>1035</b>		 <b>83.00</b>	<b>Diesel</b>		
939 B4.000	4 Cyl.		1956cc	100kW (136)PS	Turbo Intercooled TD24644 <b>340</b>
939 B5.000	4 Cyl.		1956cc	100-125kW (140-170)PS	Turbo Intercooled TD26620 <b>340</b>
939 B5.000	4 Cyl.	16.5:1	1956cc	125kW (170)PS	Turbo Intercooled TD24645 <b>340</b>
940 A5.000 Euro 5	4 Cyl.	16.5:1	1956cc	103kW (140)PS	Turbo Intercooled TD24578 <b>340</b>
940 A5.000 Euro 5	4 Cyl.	16.5:1	1956cc	103kW (140)PS	Turbo Intercooled TD26672 <b>340</b>
940 A7.000 Euro 5	4 Cyl.	16.5:1	1956cc	120kW (163)PS	Turbo Intercooled TD24793
940 A8.000 Euro 5	4 Cyl.	16.5:1	1956cc	100kW (136)PS	Turbo Intercooled TD25424



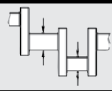
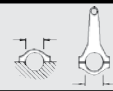

							
<b>87-436500-00</b> <b>87-436506-00</b> STD 0.40mm				<b>08-436500-00</b> <b>08-436506-00</b> STD 0.40mm			
A 43.63 B- 15.80 BØ 43.50 D 72.63  30x66		 		1.50  GDC P 1.50  P 2.00  CK P			
		<b>08344A406</b>					

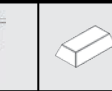
					
		<b>HR397</b>		<b>NA5070</b>  31.00x41.00x7.00mm, FPM <b>NF888</b>  93.00x172.00x12.00mm, FPM	

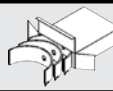
<b>1036</b>		 <b>83.00</b>	<b>Petrol</b>		
932 A2.000	4 Cyl.		1970cc	119-121kW (162-165)PS	TD18076 <b>343</b>

							
<b>87-145200-00</b> <b>87-145206-00</b> STD 0.40mm				<b>08-145200-00</b> <b>08-145206-00</b> STD 0.40mm			
A 31.00 B- 5.15 B+ 3.05 C 1.76 D 51.30  20x52		 [15] Steel		 [15] Acier		 [15] Acciaio	
		 [15] Acero					

								
BE/PL	1	50.787/50.805	53.901/53.913	19.500	1.534	0.030/0.080	EC	71-3994
MB/HL	1	59.986/60.000	63.705/63.718	20.750	1.844	0.031/0.080	EC	72-3995
TW/A	2	67.785/68.040	82.425/82.677		2.485		AL-LF	4356AF
								<b>71-3994</b> STD 0.25 [22] <b>72-3995</b> STD 0.25 0.50 <b>A191/2</b> STD

					
		<b>HR397</b>		<b>NA5070</b>  31.00x41.00x7.00mm, FPM <b>NF888</b>  93.00x172.00x12.00mm, FPM	

<b>1037</b>	<b>83.00</b>	<b>Petrol</b>	
<b>937 A1.000</b>	4 Cyl.	11.3:1	1970cc
			<b>119-122kW (162-166)PS</b>
			<b>TD16381 344</b>

<b>87-145200-00</b> <b>87-145206-00</b>	STD 0.40mm	<b>08-145200-00</b> <b>08-145206-00</b>	STD 0.40mm
<b>A</b> 31.00 <b>B-</b> 5.15 <b>B+</b> 3.05 <b>C</b> 1.76 <b>D</b> 51.30 20x52		1.20  NT [15] 1.20  P 2.00  NT	

[15] Steel                      [15] Acier                      [15] Acciaio                      [15] Acero

BE/PL	1	50.787/50.805	53.901/53.913	19.500	1.534	0.030/0.080	EC	71-3994	<b>71-3994</b> STD 0.25                      [22]
MB/HL	1	59.986/60.000	63.705/63.718	20.750	1.844	0.031/0.080	EC	72-3995	<b>72-3995</b> STD 0.25 0.50
TW/A	2	58.808/59.062	73.486/73.740		2.485		AL-LF	4351AF	<b>A190/2</b> STD

	<b>HR397</b>	<b>NA5070</b> 31.00x41.00x7.00mm, FPM <b>NF888</b> 93.00x172.00x12.00mm, FPM











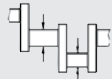
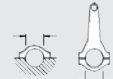

<b>1038</b>	<b>83.00</b>	<b>Petrol</b>	
-------------	--------------	---------------	--





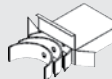

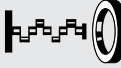







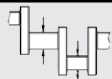

<b>AR 16201</b>	4 Cyl.	10:1	1970cc	<b>110kW (150)PS</b>	<b>TD4188 345</b>
<b>AR 32301</b>	4 Cyl.	10.1:1	1970cc	<b>114kW (155)PS</b>	<b>TD9463 346</b>
<b>AR 34103</b>	4 Cyl.	10:1	1970cc	<b>114kW (155)PS</b>	<b>TD11599 349</b>
<b>AR 67204</b>	4 Cyl.		1970cc	<b>110kW (150)PS</b>	<b>TD4190 351</b>

<b>87-110900-00</b> <b>87-110906-00</b>	STD 0.40mm	<b>08-110900-00</b> <b>08-110906-00</b>	STD 0.40mm
<b>A</b> 32.00 <b>B-</b> 3.10 <b>D</b> 56.00 20x52		1.20  CR [15] 1.50  P 3.00  CR P	

[15] Steel                      [15] Acier                      [15] Acciaio                      [15] Acero

...Continued

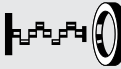
1038  83.00 Petrol										
										
BE/PL	4	50.787/50.807	53.901/53.913	19.500	1.534	0.028/0.083	BS	4350CP	71-4157/4 STD 0.25 0.50	
MB/HL 1,2,4,5	4	52.982/53.000	56.705/56.718	20.750	1.843	0.019/0.075	AL-LF	4351RA	H1096/5 STD 0.25 0.50	
MB/HL 3	1	52.982/53.000	56.705/56.718	20.750	1.838	0.029/0.085	AL-LF	4352RA		
TW/A	2	58.808/59.062	73.486/73.740		2.485		AL-LF	4351AF	A190/2 STD	
SE/PB	1	19.993/20.000	22.939/22.972	21.700			BS	4359Y	55-4540 SEMI	
										
			HR397				NA5070  31.00x41.00x7.00mm, FPM NF888  93.00x172.00x12.00mm, FPM			

1039  83.00 Petrol 										
AR 32303		4 Cyl.	10.1:1	1970cc	110-118kW (150-160)PS					TD19055 347
										
BE/PL	4	50.787/50.807	53.901/53.913	19.500	1.534	0.028/0.083	BS	4350CP	71-4157/4 STD 0.25 0.50	
MB/HL 1,2,4,5	4	52.982/53.000	56.705/56.718	20.750	1.843	0.019/0.075	AL-LF	4351RA	H1096/5 STD 0.25 0.50	
MB/HL 3	1	52.982/53.000	56.705/56.718	20.750	1.838	0.029/0.085	AL-LF	4352RA		
TW/A	2	58.808/59.062	73.486/73.740		2.485		AL-LF	4351AF	A190/2 STD	
SE/PB	1	19.993/20.000	22.939/22.972	21.700			BS	4359Y	55-4540 SEMI	
										
			HR397				NA5070  31.00x41.00x7.00mm, FPM NF888  93.00x172.00x12.00mm, FPM			

# FIAT GROUP











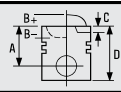
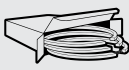

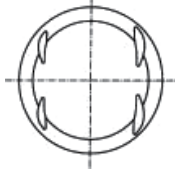
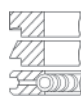
## 1040

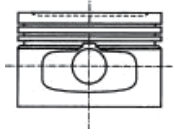
 **83.00**

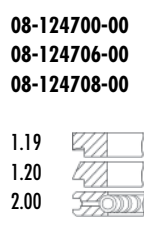
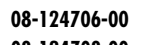
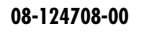

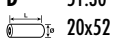



**Petrol**



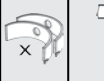
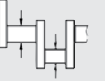
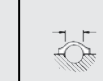
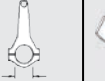

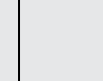
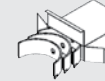

<b>AR 32310 D4</b>	4 Cyl.	10:1	1970cc	<b>110kW (150)PS</b>	<b>TD15391</b>	<b>348</b>
<b>AR 36301 D4</b>	4 Cyl.		1970cc	<b>110kW (150)PS</b>	<b>TD15392</b>	<b>350</b>

							
<b>87-145300-00</b>	STD		<b>08-145300-00</b>	STD			
<b>87-145306-00</b>	0.40mm		<b>08-145306-00</b>	0.40mm			
<b>A</b>	31.30		<b>1.20</b>	 NT [15]			
<b>B-</b>	3.80		<b>1.20</b>	 P			
<b>BØ</b>	69.00		<b>2.00</b>	 P			
<b>D</b>	51.30						
	20x52		<b>08-124700-00</b>	STD			
			<b>08-124706-00</b>	0.40mm			
			<b>08-124708-00</b>	0.60mm			
			<b>1.19</b>	 NT P			
			<b>1.20</b>	 P			
			<b>2.00</b>	 P			

[15] Steel      [15] Acier      [15] Acciaio      [15] Acero

											
BE/PL	4	50.787/50.807	53.901/53.913	19.500	1.534	0.028/0.083	BS	4350CP	<b>71-4157/4</b> STD 0.25 0.50		
MB/HL 1,2,4,5	4	52.982/53.000	56.705/56.718	20.750	1.843	0.019/0.075	AL-LF	4351RA	<b>H1096/5</b> STD 0.25 0.50		
MB/HL 3	1	52.982/53.000	56.705/56.718	20.750	1.838	0.029/0.085	AL-LF	4352RA			
TW/A	2	58.808/59.062	73.486/73.740		2.485		AL-LF	4351AF	<b>A190/2</b> STD		
SE/PB	1	19.993/20.000	22.939/22.972	21.700			BS	4359Y	<b>55-4540</b> SEMI		

		
<b>EA5420</b>	<b>HR397</b>	<b>NA5070</b>  31.00x41.00x7.00mm, FPM <b>NF888</b>  93.00x172.00x12.00mm, FPM











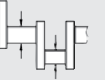

## 1041

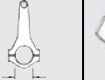
 **83.00**



**Petrol**

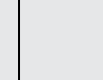









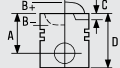
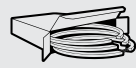

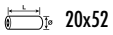
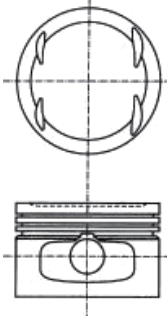
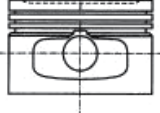



<b>AR 67299</b>	4 Cyl.	10:1	1970cc	<b>110-114kW (150-155)PS</b>	<b>TD23351</b>	<b>352</b>
-----------------	--------	------	--------	------------------------------	----------------	------------



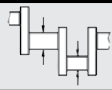
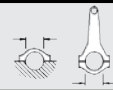

											
BE/PL	4	50.787/50.807	53.901/53.913	19.500	1.534	0.028/0.083	BS	4350CP	<b>71-4157/4</b> STD 0.25 0.50		
MB/HL 1,2,4,5	4	52.982/53.000	56.705/56.718	20.750	1.843	0.019/0.075	AL-LF	4351RA	<b>H1096/5</b> STD 0.25 0.50		
MB/HL 3	1	52.982/53.000	56.705/56.718	20.750	1.838	0.029/0.085	AL-LF	4352RA			
TW/A	2	58.808/59.062	73.486/73.740		2.485		AL-LF	4351AF	<b>A190/2</b> STD		
SE/PB	1	19.993/20.000	22.939/22.972	21.700			BS	4359Y	<b>55-4540</b> SEMI		



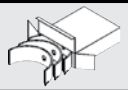



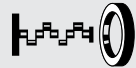

**1042**  **83.00** **Petrol**   
**AR 67202** 4 Cyl. 10:1 1995cc **104kW (141)PS** **TD137** **353**



			
<b>87-110900-00</b> STD <b>87-110906-00</b> 0.40mm  <b>A</b> 32.00 <b>B-</b> 3.10 <b>D</b> 56.00  20x52	  	<b>08-110900-00</b> STD <b>08-110906-00</b> 0.40mm  <b>1.20</b>  <b>CR [15]</b> <b>1.50</b>  <b>P</b> <b>3.00</b>  <b>CR P</b>	
[15] Steel	[15] Acier	[15] Acciaio	[15] Acero



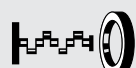



									
BE/PL	4	49.988/49.998	53.695/53.708	23.440	1.838	0.021/0.069	BS	60010CP	<b>71-4168/4</b> STD 0.25 0.50
MB/HL 1,3,5	3	59.960/59.973	63.657/63.676	25.530	1.837	0.020/0.067	BS	60011CP	<b>H1030/5</b> STD 0.25 0.50
MB/HL 2,4	2	59.960/59.973	63.657/63.676	18.360	1.837	0.020/0.067	BS	60012CP	
TW/A	4	65.786/66.040	82.423/82.677		2.362		AL-LF	2777AF	<b>A178/4</b> STD
SE/PB	1	21.994/22.000	25.120/25.146	23.720			BS	60014X	<b>55-4280</b> SEMI

		
	<b>HR397</b>	<b>NA5066</b>  35.00x50.00x10.00mm, ACM <b>NA5065</b>  62.00x80.00x12.00mm, ACM



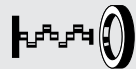









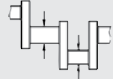

**1043**  **83.00** **Petrol**   
**185 A7.011** 5 Cyl. 9.75:1 2446cc **117-118kW (159-160)PS** **TD24638**  
**192 A7.011** 5 Cyl. 9.75:1 2446cc **123kW (167)PS** **TD25020**  
**838 B2.000** 5 Cyl. 10:1 2446cc **129kW (175)PS** **TD18864** **356**  
**841 D.000** 5 Cyl. 10.3:1 2446cc **125kW (170)PS** **TD16732** **357**





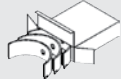
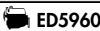

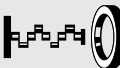





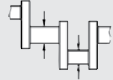

		
	<b>HR397</b>	<b>NA5070</b>  31.00x41.00x7.00mm, FPM <b>NF888</b>  93.00x172.00x12.00mm, FPM





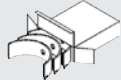







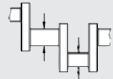

**1044**  **83.00** **Petrol**   
**192 A2.000** 5 Cyl. 10.5:1 2446cc **117-125kW (159-170)PS** **TD16396** **354**

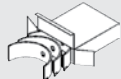

		
 <b>ED5960</b>	<b>HR397</b>	<b>NA5070</b>  31.00x41.00x7.00mm, FPM <b>NF888</b>  93.00x172.00x12.00mm, FPM

# FIAT GROUP

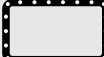





<b>1045</b>		 <b>83.00</b>	<b>Petrol</b>							
<b>838 A2.000</b>	5 Cyl.	10:1	2446cc	<b>129kW (175)PS</b>			<b>TD4617</b>	<b>355</b>		
<b>838 A2.027</b>	5 Cyl.	10:1	2446cc	<b>129kW (175)PS</b>			<b>TD14528</b>	<b>355</b>		
										
BE/PL	5	50.787/50.807	53.901/53.913	19.500	1.534	0.028/0.083	BS	4350CP	<b>71-4157/5</b> STD 0.25	
MB/HL 1-6	6	59.986/60.000	63.705/63.718	20.750	1.844	0.031/0.075	BS	4356CP	<b>H1095/6</b> STD 0.25 0.50	
TW/A	2	67.785/68.040	82.425/82.677		2.485		AL-LF	4356AF	<b>A191/2</b> STD	
SE/PB	1	19.993/20.000	22.939/22.972	21.700			BS	4359Y	<b>55-4540</b> SEMI	
										
<b>ED5960</b>		<b>HR397</b>		<b>NA5070</b>  31.00x41.00x7.00mm, FPM						
				<b>NF888</b>  93.00x172.00x12.00mm, FPM						

<b>1046</b>		 <b>83.40</b>	<b>Petrol</b>							
<b>AR 67103</b>	4 Cyl.	10.3:1	1748cc	<b>83kW (113)PS</b>			<b>TD134</b>	<b>358</b>		
										
BE/PL	4	49.988/49.998	53.695/53.708	23.440	1.838	0.021/0.069	BS	60010CP	<b>71-4168/4</b> STD 0.25 0.50	
MB/HL 1,3,5	3	59.960/59.973	63.657/63.676	25.530	1.837	0.020/0.067	BS	60011CP	<b>H1030/5</b> STD 0.25 0.50	
MB/HL 2,4	2	59.960/59.973	63.657/63.676	18.360	1.837	0.020/0.067	BS	60012CP		
TW/A	4	65.786/66.040	82.423/82.677		2.362		AL-LF	2777AF	<b>A178/4</b> STD	
SE/PB	1	21.994/22.000	25.120/25.146	23.720			BS	60014X	<b>55-4280</b> SEMI	
										
<b>NF722</b>  35.00x50.00x10.00mm, MVQ										

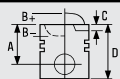
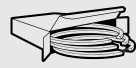





<b>1047</b>		 <b>83.50</b>	<b>Petrol</b>							
<b>AR 67105</b>	4 Cyl.	10.3:1	1748cc	<b>83-85kW (113-115)PS</b>			<b>TD135</b>	<b>359</b>		
										
BE/PL	4	49.988/49.998	53.695/53.708	23.440	1.838	0.021/0.069	BS	60010CP	<b>71-4168/4</b> STD 0.25 0.50	
MB/HL 1,3,5	3	59.960/59.973	63.657/63.676	25.530	1.837	0.020/0.067	BS	60011CP	<b>H1030/5</b> STD 0.25 0.50	
MB/HL 2,4	2	59.960/59.973	63.657/63.676	18.360	1.837	0.020/0.067	BS	60012CP		
TW/A	4	65.786/66.040	82.423/82.677		2.362		AL-LF	2777AF	<b>A178/4</b> STD	
SE/PB	1	21.994/22.000	25.120/25.146	23.720			BS	60014X	<b>55-4280</b> SEMI	
										
<b>NF722</b>  35.00x50.00x10.00mm, MVQ										





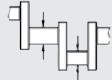
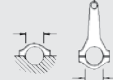

**1048**  **84.00** **Petrol** 

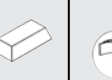
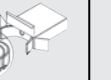
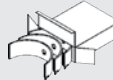

**AR 30184** 4 Cyl. 9:1 1286cc **55kW (75)PS** **TD85** **360**

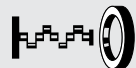
			
	<b>08-109000-10</b> STD <b>08-109008-10</b> 0.60mm  1.50  CR P 1.75  P 4.00  CR [15]		







[15] Steel [15] Acier [15] Acciaio [15] Acero

									
BE/PL	4	49.984/50.000	53.696/53.708	17.800	1.836	0.024/0.077	AL-LF	66325RA	<b>01-4178/4</b> STD 0.25 0.50
MB/HL 1-3	3	59.944/59.957	63.663/63.673	23.400	1.841	0.024/0.072	AL-LF	66326RA	<b>H1044/3</b> STD 0.25 0.50
TW/A	2	65.790/66.040	82.420/82.680		2.362		BS	66326AF	<b>A205/2</b> STD
SE/PB	1	20.996/21.000	23.005/23.020	23.500			BS	66329Y	<b>55-4505</b> SEMI

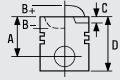
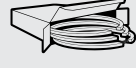
		
	<b>JH565</b>   <b>JH565</b>	<b>NA5063</b>  40.00x56.00x10.00mm, ACM <b>NA5065</b>  62.00x80.00x12.00mm, ACM

**1049**  **84.00** **Petrol** 

<b>AR 30124</b>	4 Cyl.	9:1	1490cc	<b>61-64kW (83-87)PS</b>	<b>TD78</b>	<b>361</b>
<b>AR 30128</b>	4 Cyl.	9:1	1490cc	<b>70kW (95)PS</b>	<b>TD79</b>	<b>361</b>
<b>AR 30146</b>	4 Cyl.	9.5:1	1490cc	<b>75-77kW (102-105)PS</b>	<b>TD80</b>	<b>363</b>
<b>AR 30182</b>	4 Cyl.		1490cc	<b>70kW (95)PS</b>	<b>TD10128</b>	<b>364</b>
<b>AR 30504</b>	4 Cyl.	9:1	1490cc	<b>62kW (84)PS</b>	<b>TD89</b>	<b>365</b>
<b>AR 30508</b>	4 Cyl.		1490cc	<b>77kW (105)PS</b>	<b>TD90</b>	<b>363</b>
<b>AR 30520</b>	4 Cyl.	9:1	1490cc	<b>66kW (90)PS</b>	<b>TD91</b>	<b>361</b>









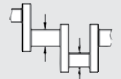

			
	<b>08-109000-10</b> STD <b>08-109008-10</b> 0.60mm  1.50  CR P 1.75  P 4.00  CR [15]		

[15] Steel [15] Acier [15] Acciaio [15] Acero

# FIAT GROUP

...Continued

## 1049 84.00 Petrol

									
BE/PL	4	49.984/50.000	53.696/53.708	17.800	1.836	0.024/0.077	AL-LF	66325RA	<b>01-4178/4</b> STD 0.25 0.50
BE/PL	4	49.992/50.000	53.696/53.708	17.800	1.836	0.024/0.069	AL-LF	66625RA	<b>01-4188/4</b> STD 0.25 0.50



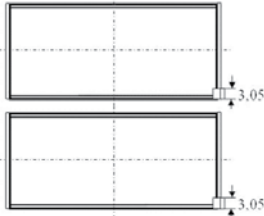

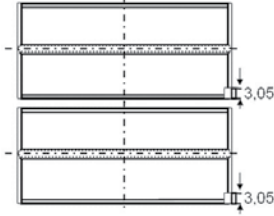

66325RA



66625RA











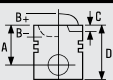
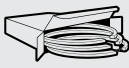





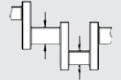

MB/HL 1-3	3	59.944/59.957	63.663/63.673	23.400	1.841	0.024/0.072	AL-LF	66326RA	<b>H1044/3</b> STD 0.25 0.50
TW/A	2	65.790/66.040	82.420/82.680		2.362		BS	66326AF	<b>A205/2</b> STD
SE/PB	1	20.996/21.000	23.005/23.020	23.500			BS	66329Y	<b>55-4505</b> SEMI

		
	JH565	NA5063  40.00x56.00x10.00mm, ACM NA5065  62.00x80.00x12.00mm, ACM
		
	JH565	

## 1050 84.00 Petrol

AR 30143 4 Cyl. 1490cc 62kW (84)PS TD10131 362

			
	<b>08-109000-10</b> STD <b>08-109008-10</b> 0.60mm  1.50  CR P 1.75  P 4.00  CR [15]		
[15] Steel	[15] Acier	[15] Acciaio	[15] Acero

									
MB/HL 1-3	3	59.944/59.957	63.663/63.673	23.400	1.841	0.024/0.072	AL-LF	66326RA	<b>H1044/3</b> STD 0.25 0.50
TW/A	2	65.790/66.040	82.420/82.680		2.362		BS	66326AF	<b>A205/2</b> STD
SE/PB	1	20.996/21.000	23.005/23.020	23.500			BS	66329Y	<b>55-4505</b> SEMI

<b>1051</b>	<b>84.00</b>	<b>Petrol</b>			
<b>AR 30198</b>	4 Cyl.	9:1	1490cc	<b>70kW (95)PS</b>	<b>TD86</b>
<b>AR 30734</b>	4 Cyl.		1490cc	<b>77kW (105)PS</b>	<b>TD108 368</b>
<b>AR 30738</b>	4 Cyl.	9.5:1	1490cc	<b>70-77kW (95-105)PS</b>	<b>TD23346</b>
<b>AR 31016</b>	4 Cyl.	9:1	1490cc	<b>70kW (95)PS</b>	<b>TD101</b>

BE/PL	4	49.984/50.000	53.696/53.708	17.800	1.836	0.024/0.077	AL-LF	66325RA	<b>01-4178/4</b> STD 0.25 0.50
BE/PL	4	49.992/50.000	53.696/53.708	17.800	1.836	0.024/0.069	AL-LF	66625RA	<b>01-4188/4</b> STD 0.25 0.50

**66325RA**

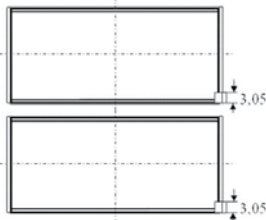

**66625RA**

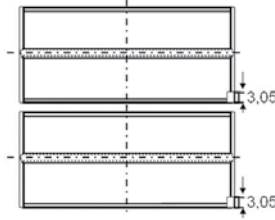

MB/HL 1-3	3	59.944/59.957	63.663/63.673	23.400	1.841	0.024/0.072	AL-LF	66326RA	<b>H1044/3</b> STD 0.25 0.50
TW/A	2	65.790/66.040	82.420/82.680		2.362		BS	66326AF	<b>A205/2</b> STD
SE/PB	1	20.996/21.000	23.005/23.020	23.500			BS	66329Y	<b>55-4505</b> SEMI

<b>1052</b>	<b>84.00</b>	<b>Petrol</b>			
<b>AR 30514</b>	4 Cyl.		1490cc	<b>70kW (95)PS</b>	<b>TD6373 366</b>

	<b>08-109000-10</b> STD		
	<b>08-109008-10</b> 0.60mm		
	1.50  CR P		
	1.75  P		
	4.00  CR [15]		

[15] Steel      [15] Acier      [15] Acciaio      [15] Acero

BE/PL	4	49.984/50.000	53.696/53.708	17.800	1.836	0.024/0.077	AL-LF	66325RA	<b>01-4178/4</b> STD 0.25 0.50
BE/PL	4	49.992/50.000	53.696/53.708	17.800	1.836	0.024/0.069	AL-LF	66625RA	<b>01-4188/4</b> STD 0.25 0.50

**66325RA**

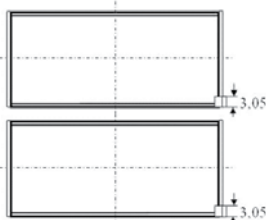

**66625RA**

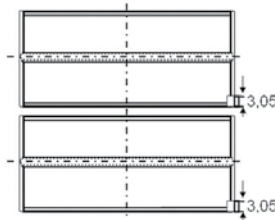

MB/HL 1-3	3	59.944/59.957	63.663/63.673	23.400	1.841	0.024/0.072	AL-LF	66326RA	<b>H1044/3</b> STD 0.25 0.50
TW/A	2	65.790/66.040	82.420/82.680		2.362		BS	66326AF	<b>A205/2</b> STD
SE/PB	1	20.996/21.000	23.005/23.020	23.500			BS	66329Y	<b>55-4505</b> SEMI

# FIAT GROUP

## 1053



84.00

Petrol



AR 30588 4 Cyl. 1490cc 75-77kW (102-105)PS TD98 367

BE/PL	4	49.984/50.000	53.696/53.708	17.800	1.836	0.024/0.077	AL-LF	66325RA	<b>01-4178/4</b> STD 0.25 0.50
BE/PL	4	49.992/50.000	53.696/53.708	17.800	1.836	0.024/0.069	AL-LF	66625RA	<b>01-4188/4</b> STD 0.25 0.50

66325RA

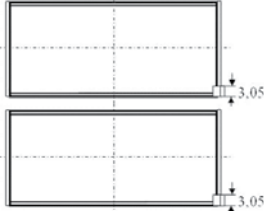

66625RA



MB/HL 1-3	3	59.944/59.957	63.663/63.673	23.400	1.841	0.024/0.072	AL-LF	66326RA	<b>H1044/3</b> STD 0.25 0.50
TW/A	2	65.790/66.040	82.420/82.680		2.362		BS	66326AF	<b>A205/2</b> STD
SE/PB	1	20.996/21.000	23.005/23.020	23.500			BS	66329Y	<b>55-4505</b> SEMI



JH565



JH565

NA5063 40.00x56.00x10.00mm, ACM  
NA5065 62.00x80.00x12.00mm, ACM

## 1054



84.00

Petrol



AR 30750 4 Cyl. 1490cc 74kW (101)PS TD116 369

AR 30751 4 Cyl. 1490cc 71-72kW (97-98)PS TD117 370

BE/PL	4	49.984/50.000	53.696/53.708	17.800	1.836	0.024/0.077	AL-LF	66325RA	<b>01-4178/4</b> STD 0.25 0.50
BE/PL	4	49.992/50.000	53.696/53.708	17.800	1.836	0.024/0.069	AL-LF	66625RA	<b>01-4188/4</b> STD 0.25 0.50

66325RA

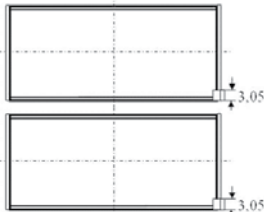



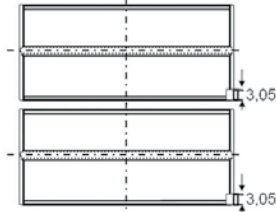











66625RA



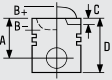









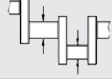



MB/HL 1-3	3	59.944/59.957	63.663/63.673	23.400	1.841	0.024/0.072	AL-LF	66326RA	<b>H1044/3</b> STD 0.25 0.50
TW/A	2	65.790/66.040	82.420/82.680		2.362		BS	66326AF	<b>A205/2</b> STD
SE/PB	1	20.996/21.000	23.005/23.020	23.500			BS	66329Y	<b>55-4505</b> SEMI

...Continued

<b>1054</b>	 <b>84.00</b>	<b>Petrol</b>
		
	<b>JJ450</b>  <b>JJ450</b>	<b>NA5063</b>  40.00x56.00x10.00mm, ACM <b>NA5065</b>  62.00x80.00x12.00mm, ACM

<b>1055</b>	 <b>84.00</b>	<b>Petrol</b>				
<b>124 B3.000</b>	4 Cyl.	8.9:1	1585cc	<b>46kW (63)PS</b>	<b>TD6898</b>	<b>371</b>
						
	<b>08-207600-00</b> STD <b>08-207604-00</b> 0.20mm <b>08-207606-00</b> 0.40mm <b>08-207608-00</b> 0.60mm  1.50  CR P 2.00  P 3.95  CR [15]					
[15] Steel	[15] Acier	[15] Acciaio	[15] Acero			

									
BE/PL	4	50.782/50.802	53.897/53.913	19.500	1.537	0.021/0.082	AL-LF	66240RA	<b>01-4175/4</b> STD 0.25 0.50 0.75 1.00
<b>Mot.402353</b> →									
MB/HL 1,2,4,5	4	52.985/53.005	56.717/56.730	20.750	1.841	0.030/0.088	AL-LF	66316RA	<b>H1043/5</b> STD 0.25 0.50 0.75
MB/HL 3	1	52.985/53.005	56.717/56.730	24.250	1.841	0.030/0.088	AL-LF	66317RA	
TW/A	2	59.000/59.250	73.600/73.850		2.362		BS	62037AF	<b>A201/2</b> STD .005
SE/PB	1	21.539/21.641	23.939/23.972	25.100			BS	62039Y	<b>55-4288</b> SEMI

		
	<b>JH111</b>  <b>JH111</b>	

# FIAT GROUP

<b>1056</b>	<b>84.00</b>	<b>Petrol</b>					
<b>131 A1.000</b>	4 Cyl.	9.2:1	1585cc	<b>55kW (75)PS</b>		<b>TD896</b>	<b>372</b>

				<b>08-207600-00</b> STD <b>08-207604-00</b> 0.20mm <b>08-207606-00</b> 0.40mm <b>08-207608-00</b> 0.60mm  1.50  CR P 2.00  P 3.95  CR [15]				

[15] Steel      [15] Acier      [15] Acciaio      [15] Acero

BE/PL	4	48.224/48.244	51.330/51.346	19.500	1.540	0.020/0.067	AL-LF	66315RA	<b>01-4176/4</b> STD 0.25 0.50
MB/HL 1,2,4,5	4	52.985/53.005	56.717/56.730	20.750	1.841	0.030/0.088	AL-LF	66316RA	<b>H1043/5</b> STD 0.25 0.50 0.75
MB/HL 3	1	52.985/53.005	56.717/56.730	24.250	1.841	0.030/0.088	AL-LF	66317RA	
TW/A	2	59.000/59.250	73.600/73.850		2.362		BS	62037AF	<b>A201/2</b> STD .005
SE/PB	1	21.539/21.641	25.000/25.021	25.100			BS	66649Y	<b>55-4193</b> SEMI

				JH111					
				JH111					

<b>1057</b>	<b>84.00</b>	<b>Petrol</b>					
<b>131 AB.1A.0</b>	4 Cyl.	9.2:1	1585cc	<b>55kW (75)PS</b>		<b>TD21454</b>	









BE/PL	4	48.224/48.244	51.330/51.346	19.500	1.540	0.020/0.067	AL-LF	66315RA	<b>01-4176/4</b> STD 0.25 0.50
MB/HL 1,2,4,5	4	52.985/53.005	56.717/56.730	20.750	1.841	0.030/0.088	AL-LF	66316RA	<b>H1043/5</b> STD 0.25 0.50 0.75
MB/HL 3	1	52.985/53.005	56.717/56.730	24.250	1.841	0.030/0.088	AL-LF	66317RA	
TW/A	2	59.000/59.250	73.600/73.850		2.362		BS	62037AF	<b>A201/2</b> STD .005
SE/PB	1	21.539/21.641	25.000/25.021	25.100			BS	66649Y	<b>55-4193</b> SEMI

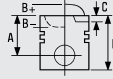
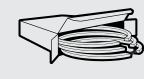

## 1058

 **84.00**
**Petrol**

<b>131 B1.000</b>	4 Cyl.	9:1	1585cc	<b>72kW (98)PS</b>	<b>TD901</b>	<b>373</b>
<b>132 C.000</b>	4 Cyl.	9:1	1585cc	<b>65-72kW (89-98)PS</b>	<b>TD909</b>	<b>376</b>
<b>132 D.000</b>	4 Cyl.	9:1	1585cc	<b>72kW (98)PS</b>	<b>TD911</b>	<b>378</b>
<b>138 AR.000</b>	4 Cyl.	9.3:1	1585cc	<b>66-77kW (90-105)PS</b>	<b>TD919</b>	<b>379</b>









				<b>08-207600-00</b> STD <b>08-207604-00</b> 0.20mm <b>08-207606-00</b> 0.40mm <b>08-207608-00</b> 0.60mm
				1.50  CR P 2.00  P 3.95  CR [15]
				<b>08-215300-10</b> STD <b>08-215306-10</b> 0.40mm <b>08-215308-10</b> 0.60mm <b>02/88</b> →
				1.50  CR P 2.00  P 3.95  P

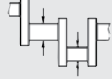
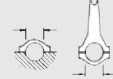

[15] Steel

[15] Acier

[15] Acciaio

[15] Acero

									
BE/PL	4	48.224/48.244	51.330/51.346	19.500	1.540	0.020/0.067	AL-LF	66315RA	<b>01-4176/4</b> STD 0.25 0.50
MB/HL 1,2,4,5	4	52.985/53.005	56.717/56.730	20.750	1.841	0.030/0.088	AL-LF	66316RA	<b>H1043/5</b> STD 0.25 0.50 0.75
MB/HL 3	1	52.985/53.005	56.717/56.730	24.250	1.841	0.030/0.088	AL-LF	66317RA	
TW/A	2	59.000/59.250	73.600/73.850		2.362		BS	62037AF	<b>A201/2</b> STD .005
SE/PB	1	21.539/21.641	23.939/23.972	25.100			BS	62039Y	<b>55-4288</b> SEMI

		
---	---	---

**JH111**
**NB818**  40.00x56.00x7.00mm, ACM

**NA5050**  70.00x90.00x10.00mm, ACM

**JH111**

# FIAT GROUP

## 1059



84.00

Petrol



131 C2.000

4 Cyl.

9.1:1

1585cc

63kW (85)PS

TD4351

374

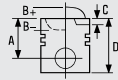

08-207600-00 STD  
 08-207604-00 0.20mm  
 08-207606-00 0.40mm  
 08-207608-00 0.60mm

1.50 CR P  
 2.00 P  
 3.95 CR [15]

[15] Steel

[15] Acier

[15] Acciaio

[15] Acero

BE/PL	4	48.224/48.244	51.330/51.346	19.500	1.540	0.020/0.067	AL-LF	66315RA	01-4176/4 STD 0.25 0.50		
MB/HL 1,2,4,5	4	52.985/53.005	56.717/56.730	20.750	1.841	0.030/0.088	AL-LF	66316RA	H1043/5 STD 0.25 0.50 0.75		
MB/HL 3	1	52.985/53.005	56.717/56.730	24.250	1.841	0.030/0.088	AL-LF	66317RA			
TW/A	2	59.000/59.250	73.600/73.850		2.362		BS	62037AF	A201/2 STD .005		
SE/PB	1	21.539/21.641	23.939/23.972	25.100			BS	62039Y	55-4288 SEMI		



JH111

NB818 40.00x56.00x7.00mm, ACM

NA5050 70.00x90.00x10.00mm, ACM



JH111

## 1060



84.00

Petrol



131 C3.000

4 Cyl.

1585cc

71-72kW (96-98)PS

TD904

375

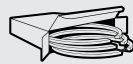
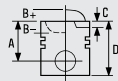

08-207600-00 STD  
 08-207604-00 0.20mm  
 08-207606-00 0.40mm  
 08-207608-00 0.60mm

1.50 CR P  
 2.00 P  
 3.95 CR [15]

[15] Steel









[15] Acier

[15] Acciaio

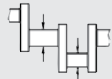
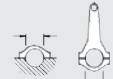
[15] Acero

...Continued

**1060**  **84.00** **Petrol**

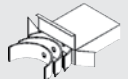

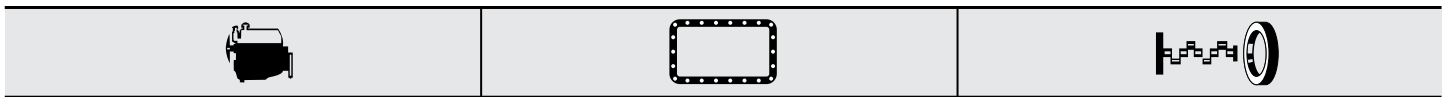
									
BE/PL	4	48.224/48.244	51.330/51.346	19.500	1.540	0.020/0.067	AL-LF	66315RA	<b>01-4176/4</b> STD 0.25 0.50
MB/HL 1,2,4,5	4	52.985/53.005	56.717/56.730	20.750	1.841	0.030/0.088	AL-LF	66316RA	<b>H1043/5</b> STD 0.25 0.50 0.75
MB/HL 3	1	52.985/53.005	56.717/56.730	24.250	1.841	0.030/0.088	AL-LF	66317RA	
TW/A	2	59.000/59.250	73.600/73.850		2.362		BS	62037AF	<b>A201/2</b> STD .005
SE/PB	1	21.539/21.641	23.939/23.972	25.100			BS	62039Y	<b>55-4288</b> SEMI











JH111

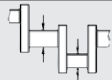
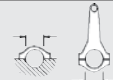

JH111

**1061**  **84.00** **Petrol** 

<b>132 AZ2.000</b>	4 Cyl.	1995cc	<b>51kW (69)PS</b>	<b>TD13028</b>	<b>429</b>
<b>132 C6.000</b>	4 Cyl.	1585cc	<b>66kW (90)PS</b>	<b>TD912</b>	<b>377</b>
<b>132 CB.0A.0</b>	4 Cyl.	9:1 1585cc	<b>72kW (98)PS</b>	<b>TD21458</b>	

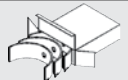
									
BE/PL	4	48.224/48.244	51.330/51.346	19.500	1.540	0.020/0.067	AL-LF	66315RA	<b>01-4176/4</b> STD 0.25 0.50
MB/HL 1,2,4,5	4	52.985/53.005	56.717/56.730	20.750	1.841	0.030/0.088	AL-LF	66316RA	<b>H1043/5</b> STD 0.25 0.50 0.75
MB/HL 3	1	52.985/53.005	56.717/56.730	24.250	1.841	0.030/0.088	AL-LF	66317RA	
TW/A	2	59.000/59.250	73.600/73.850		2.362		BS	62037AF	<b>A201/2</b> STD .005
SE/PB	1	21.539/21.641	23.939/23.972	25.100			BS	62039Y	<b>55-4288</b> SEMI

## 1062

84.00

**Petrol**



138 AR.048

4 Cyl.

9.3:1

1585cc

74kW (100)PS

TD920

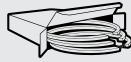
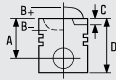

**08-207600-00** STD  
**08-207604-00** 0.20mm  
**08-207606-00** 0.40mm  
**08-207608-00** 0.60mm

1.50 CR P  
 2.00 P  
 3.95 CR [15]

**08-215300-10** STD  
**08-215306-10** 0.40mm  
**08-215308-10** 0.60mm  
 02/88 →

1.50 CR P  
 2.00 P  
 3.95 P

[15] Steel

[15] Acier

[15] Acciaio

[15] Acero

BE/PL	4	48.224/48.244	51.330/51.346	19.500	1.540	0.020/0.067	AL-LF	66315RA	<b>01-4176/4</b> STD 0.25 0.50
MB/HL 1,2,4,5	4	52.985/53.005	56.717/56.730	20.750	1.841	0.030/0.088	AL-LF	66316RA	<b>H1043/5</b> STD 0.25 0.50 0.75
MB/HL 3	1	52.985/53.005	56.717/56.730	24.250	1.841	0.030/0.088	AL-LF	66317RA	
TW/A	2	59.000/59.250	73.600/73.850		2.362		BS	62037AF	<b>A201/2</b> STD .005
SE/PB	1	21.539/21.641	23.939/23.972	25.100			BS	62039Y	<b>55-4288</b> SEMI

## 1063

84.00

**Petrol**



149 A.000

4 Cyl.

9.3:1

1585cc

60kW (82)PS

TD962

149 C2.000

4 Cyl.

9.5:1

1595cc

66kW (90)PS

TD4384

149 C2.046

4 Cyl.

9.5:1

1595cc

66kW (90)PS

TD978

392

149 C3.000

4 Cyl.

9.5:1

1585cc

61-76kW (83-103)PS

TD18856

383

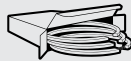
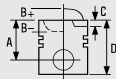

**08-207600-00** STD  
**08-207604-00** 0.20mm  
**08-207606-00** 0.40mm  
**08-207608-00** 0.60mm

1.50 CR P  
 2.00 P  
 3.95 CR [15]









[15] Steel



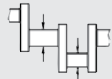
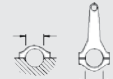



[15] Acier

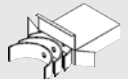



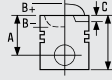

[15] Acciaio

[15] Acero









...Continued

<b>1063</b>		 <b>84.00</b>	<b>Petrol</b>							
										
BE/PL	4	48.224/48.244	51.330/51.346	19.500	1.540	0.020/0.067	AL-LF	66315RA	<b>01-4176/4</b> STD 0.25 0.50	
MB/HL 1,2,4,5	4	52.985/53.005	56.717/56.730	20.750	1.841	0.030/0.088	AL-LF	66316RA	<b>H1043/5</b> STD 0.25 0.50 0.75	
MB/HL 3	1	52.985/53.005	56.717/56.730	24.250	1.841	0.030/0.088	AL-LF	66317RA		
TW/A	2	59.000/59.250	73.600/73.850		2.362		BS	62037AF	<b>A201/2</b> STD .005	
SE/PB	1	21.539/21.641	23.939/23.972	25.100			BS	62039Y	<b>55-4288</b> SEMI	

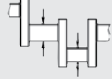
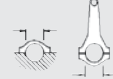
<b>1064</b>		 <b>84.00</b>	<b>Petrol</b>							
<b>149 A2.000</b>	4 Cyl.	9.3:1	1585cc	<b>74kW (101)PS</b>						 <b>380</b>
										



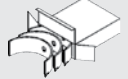

<p><b>08-207600-00</b> STD  <b>08-207604-00</b> 0.20mm  <b>08-207606-00</b> 0.40mm  <b>08-207608-00</b> 0.60mm</p> <p>1.50  CR P            2.00  P            3.95  CR [15]</p>		<p><b>08-215300-10</b> STD  <b>08-215306-10</b> 0.40mm  <b>08-215308-10</b> 0.60mm            02/88 →</p> <p>1.50  CR P            2.00  P            3.95  P</p>	
--	--	--	--







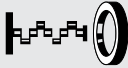

[15] Steel      [15] Acier      [15] Acciaio      [15] Acero



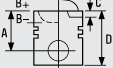
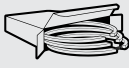





<b>1063</b>		 <b>84.00</b>	<b>Petrol</b>							
										
BE/PL	4	48.224/48.244	51.330/51.346	19.500	1.540	0.020/0.067	AL-LF	66315RA	<b>01-4176/4</b> STD 0.25 0.50	
MB/HL 1,2,4,5	4	52.985/53.005	56.717/56.730	20.750	1.841	0.030/0.088	AL-LF	66316RA	<b>H1043/5</b> STD 0.25 0.50 0.75	
MB/HL 3	1	52.985/53.005	56.717/56.730	24.250	1.841	0.030/0.088	AL-LF	66317RA		
TW/A	2	59.000/59.250	73.600/73.850		2.362		BS	62037AF	<b>A201/2</b> STD .005	
SE/PB	1	21.539/21.641	23.939/23.972	25.100			BS	62039Y	<b>55-4288</b> SEMI	



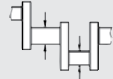

# FIAT GROUP

...Continued

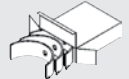
<b>1064</b>	 <b>84.00</b>	<b>Petrol</b>
		
	JH111	
		
	JH111	

<b>1065</b>	 <b>84.00</b>	<b>Petrol</b>				
149 A4.000	4 Cyl.	9.3:1	1585cc	74kW (101)PS	TD4380	381
						
	<b>08-207600-00</b> STD <b>08-207604-00</b> 0.20mm <b>08-207606-00</b> 0.40mm <b>08-207608-00</b> 0.60mm  1.50  CR P 2.00  P 3.95  CR [15]					
[15] Steel	[15] Acier	[15] Acciaio	[15] Acero			

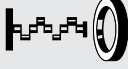
									
BE/PL	4	48.224/48.244	51.330/51.346	19.500	1.540	0.020/0.067	AL-LF	66315RA	<b>01-4176/4</b> STD 0.25 0.50
MB/HL 1,2,4,5	4	52.985/53.005	56.717/56.730	20.750	1.841	0.030/0.088	AL-LF	66316RA	<b>H1043/5</b> STD 0.25 0.50 0.75
MB/HL 3	1	52.985/53.005	56.717/56.730	24.250	1.841	0.030/0.088	AL-LF	66317RA	
TW/A	2	59.000/59.250	73.600/73.850		2.362		BS	62037AF	<b>A201/2</b> STD .005
SE/PB	1	21.539/21.641	23.939/23.972	25.100			BS	62039Y	<b>55-4288</b> SEMI

		
	JH111 JJ413	
		
	JH111	JJ413

## 1066

### 84.00

### Petrol



<b>149 C2.000</b>	4 Cyl.	9.5:1	1585cc	<b>66kW (90)PS</b>	<b>TD5432</b>	<b>382</b>
<b>831 B7.000</b>	4 Cyl.	9.5:1	1585cc	<b>80kW (109)PS</b>	<b>TD1817</b>	<b>390</b>

<p><b>08-207600-00</b> STD</p> <p><b>08-207604-00</b> 0.20mm</p> <p><b>08-207606-00</b> 0.40mm</p> <p><b>08-207608-00</b> 0.60mm</p> <p>1.50  CR P</p> <p>2.00  P</p> <p>3.95  CR [15]</p>		<p><b>14-011041-00 D</b></p> <p><b>B 88.06 C 152.00</b></p>	
<p><b>08-215300-10</b> STD</p> <p><b>08-215306-10</b> 0.40mm</p> <p><b>08-215308-10</b> 0.60mm</p> <p>02/88 →</p> <p>1.50  CR P</p> <p>2.00  P</p> <p>3.95  P</p>			

[15] Steel      [15] Acier      [15] Acciaio      [15] Acero

BE/PL	4	48.224/48.244	51.330/51.346	19.500	1.540	0.020/0.067	AL-LF	66315RA	<b>01-4176/4</b> STD 0.25 0.50
MB/HL 1,2,4,5	4	52.985/53.005	56.717/56.730	20.750	1.841	0.030/0.088	AL-LF	66316RA	<b>H1043/5</b> STD 0.25 0.50 0.75
MB/HL 3	1	52.985/53.005	56.717/56.730	24.250	1.841	0.030/0.088	AL-LF	66317RA	
TW/A	2	59.000/59.250	73.600/73.850		2.362		BS	62037AF	<b>A201/2</b> STD .005
SE/PB	1	21.539/21.641	23.939/23.972	25.100			BS	62039Y	<b>55-4288</b> SEMI

## 1067

 **84.00**



**Petrol**

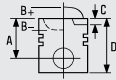

154 A.048      4 Cyl.      9.75:1      1585cc      **61kW (83)PS**      TD11754      **384**











**08-207600-00** STD  
**08-207604-00** 0.20mm  
**08-207606-00** 0.40mm  
**08-207608-00** 0.60mm

1.50  CR P  
 2.00  P  
 3.95  CR [15]

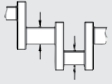
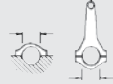
**08-215300-10** STD  
**08-215306-10** 0.40mm  
**08-215308-10** 0.60mm  
 02/88 →

1.50  CR P  
 2.00  P  
 3.95  P

[15] Steel      [15] Acier      [15] Acciaio      [15] Acero

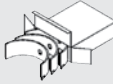

									
BE/PL	4	48.224/48.244	51.330/51.346	19.500	1.540	0.020/0.067	AL-LF	66315RA	<b>01-4176/4</b> STD 0.25 0.50
MB/HL 1,2,4,5	4	52.985/53.005	56.717/56.730	20.750	1.841	0.030/0.088	AL-LF	66316RA	<b>H1043/5</b> STD 0.25 0.50 0.75
MB/HL 3	1	52.985/53.005	56.717/56.730	24.250	1.841	0.030/0.088	AL-LF	66317RA	
TW/A	2	59.000/59.250	73.600/73.850		2.362		BS	62037AF	<b>A201/2</b> STD .005
SE/PB	1	21.539/21.641	23.939/23.972	25.100			BS	62039Y	<b>55-4288</b> SEMI



**JJ298**  
(Cork)



**JJ298**

**NB742**  30.00x43.00x8.00mm, ACM  
**NA5050**  70.00x90.00x10.00mm, ACM



## 1068

### 84.00

### Petrol



<b>828 B.000</b>	4 Cyl.	9.3:1	1585cc	<b>74kW (100)PS</b>	<b>TD1796</b>	<b>385</b>
<b>828 B1.000</b>	4 Cyl.	8.9:1	1995cc	<b>85-88kW (116-119)PS</b>	<b>TD1797</b>	<b>385</b>

<p><b>08-207600-00</b> STD  <b>08-207604-00</b> 0.20mm  <b>08-207606-00</b> 0.40mm  <b>08-207608-00</b> 0.60mm</p> <p>1.50  CR P                  2.00  P                  3.95  CR [15]</p>			
<p><b>08-215300-10</b> STD  <b>08-215306-10</b> 0.40mm  <b>08-215308-10</b> 0.60mm                  02/88 →</p> <p>1.50  CR P                  2.00  P                  3.95  P</p>			

[15] Steel      [15] Acier      [15] Acciaio      [15] Acero

BE/PL	4	48.224/48.244	51.330/51.346	19.500	1.540	0.020/0.067	AL-LF	66315RA	<b>01-4176/4</b> STD 0.25 0.50
MB/HL 1,2,4,5	4	52.985/53.005	56.717/56.730	20.750	1.841	0.030/0.088	AL-LF	66316RA	<b>H1043/5</b> STD 0.25 0.50 0.75
MB/HL 3	1	52.985/53.005	56.717/56.730	24.250	1.841	0.030/0.088	AL-LF	66317RA	
TW/A	2	59.000/59.250	73.600/73.850		2.362		BS	62037AF	<b>A201/2</b> STD .005
SE/PB	1	21.539/21.641	23.939/23.972	25.100			BS	62039Y	<b>55-4288</b> SEMI

--	--	--

JH111



JH111

# FIAT GROUP

## 1069

 84.00

Petrol



831 A4.000

4 Cyl.







9.5:1

1585cc

77kW (105)PS

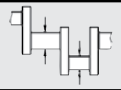
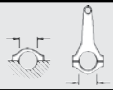
TD4604

386

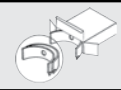
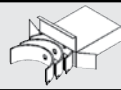
									
BE/PL	4	48.224/48.244	51.330/51.346	19.500	1.540	0.020/0.067	AL-LF	66315RA	<b>01-4176/4</b> STD 0.25 0.50
MB/HL 1,2,4,5	4	52.985/53.005	56.717/56.730	20.750	1.841	0.030/0.088	AL-LF	66316RA	<b>H1043/5</b> STD 0.25 0.50 0.75
MB/HL 3	1	52.985/53.005	56.717/56.730	24.250	1.841	0.030/0.088	AL-LF	66317RA	
TW/A	2	59.000/59.250	73.600/73.850		2.362		BS	62037AF	<b>A201/2</b> STD .005
SE/PB	1	21.539/21.641	23.939/23.972	25.100			BS	62039Y	<b>55-4288</b> SEMI



JH111

NB732  74.00x90.00x10.00mm, FPM



JH111

## 1070

 84.00

Petrol



831 A7.000

4 Cyl.

8:1







1585cc

96kW (130)PS

Turbo Intercooled

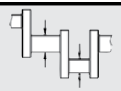
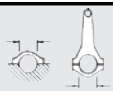
TD1808

387

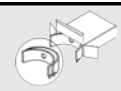
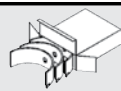
									
BE/PL	4	48.224/48.244	51.330/51.346	19.500	1.540	0.020/0.067	AL-LF	66315RA	<b>01-4176/4</b> STD 0.25 0.50
MB/HL 1,2,4,5	4	52.990/53.010	56.717/56.735	20.750	1.843	0.020/0.080	BS	4128CP	<b>H1084/5</b> STD 0.25 0.50
MB/HL 3	1	52.990/53.010	56.717/56.735	24.250	1.843	0.020/0.080	BS	4129CP	
TW/A	2	59.000/59.250	73.600/73.850		2.362		BS	62037AF	<b>A201/2</b> STD .005
SE/PB	1	21.539/21.641	23.939/23.972	25.100			BS	62039Y	<b>55-4288</b> SEMI















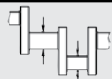







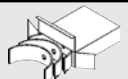

JJ298



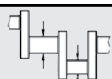
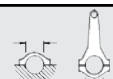

(Cork)



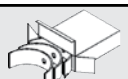







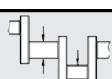
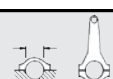

JJ298

<b>1071</b>  <b>84.00</b> <b>Petrol</b> 										
831 B3.000		4 Cyl.	8:1	1585cc	103kW (140)PS		Turbo Intercooled		TD1807 <b>388</b>	
										
BE/PL	4	48.224/48.244	51.330/51.346	19.500	1.540	0.020/0.067	AL-LF	66315RA	<b>01-4176/4</b> STD 0.25 0.50	
MB/HL 1,2,4,5	4	52.990/53.010	56.717/56.735	20.750	1.843	0.020/0.080	BS	4128CP	<b>H1084/5</b> STD 0.25 0.50	
MB/HL 3	1	52.990/53.010	56.717/56.735	24.250	1.843	0.020/0.080	BS	4129CP		
TW/A	2	59.000/59.250	73.600/73.850		2.362		BS	62037AF	<b>A201/2</b> STD .005	
SE/PB	1	21.539/21.641	23.939/23.972	25.100			BS	62039Y	<b>55-4288</b> SEMI	

<b>1072</b>  <b>84.00</b> <b>Petrol</b> 										
831 B6.000		4 Cyl.	1585cc	73kW (99)PS				TD1815 <b>389</b>		
										
BE/PL	4	48.224/48.244	51.330/51.346	19.500	1.540	0.020/0.067	AL-LF	66315RA	<b>01-4176/4</b> STD 0.25 0.50	
MB/HL 1,2,4,5	4	52.985/53.005	56.717/56.730	20.750	1.841	0.030/0.088	AL-LF	66316RA	<b>H1043/5</b> STD 0.25 0.50 0.75	
MB/HL 3	1	52.985/53.005	56.717/56.730	24.250	1.841	0.030/0.088	AL-LF	66317RA		
TW/A	2	59.000/59.250	73.600/73.850		2.362		BS	62037AF	<b>A201/2</b> STD .005	
SE/PB	1	21.539/21.641	23.939/23.972	25.100			BS	62039Y	<b>55-4288</b> SEMI	

		
<p>JJ298 (Cork)</p>  <p>JJ298</p>		

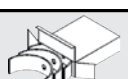
<b>1073</b>  <b>84.00</b> <b>Petrol</b> 										
831 B7.046		4 Cyl.	9.5:1	1585cc	97kW (132)PS		Turbo Intercooled		TD4606 <b>391</b>	
										
BE/PL	4	48.224/48.244	51.330/51.346	19.500	1.540	0.020/0.067	AL-LF	66315RA	<b>01-4176/4</b> STD 0.25 0.50	
MB/HL 1,2,4,5	4	52.990/53.010	56.717/56.735	20.750	1.843	0.020/0.080	BS	4128CP	<b>H1084/5</b> STD 0.25 0.50	
MB/HL 3	1	52.990/53.010	56.717/56.735	24.250	1.843	0.020/0.080	BS	4129CP		
TW/A	2	59.000/59.250	73.600/73.850		2.362		BS	62037AF	<b>A201/2</b> STD .005	
SE/PB	1	21.539/21.641	23.939/23.972	25.100			BS	62039Y	<b>55-4288</b> SEMI	

# FIAT GROUP

...Continued

**1073**  **84.00** **Petrol**

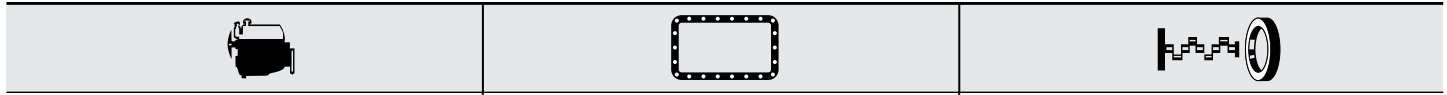

JH111



JH111









**1074**  **84.00** **Petrol** 

AR 33201 4 Cyl. 9.5:1 1596cc 76kW (103)PS TD121 393

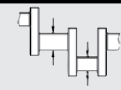

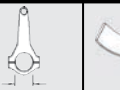
08-110200-00 STD

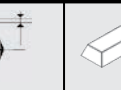
- 1.50  CR P
- 1.50  P
- 3.50  P

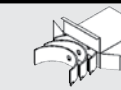

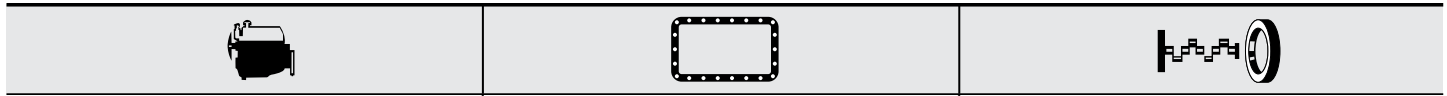
										
BE/PL	4	48.226/48.244	51.354/51.366	19.100	1.543	0.020/0.080	BS	4355CP	<b>71-4158/4</b> STD 0.25	
MB/HL 1,2,4,5	4	52.982/53.000	56.705/56.718	20.750	1.843	0.019/0.075	AL-LF	4351RA	<b>H1096/5</b> STD 0.25 0.50	
MB/HL 3	1	52.982/53.000	56.705/56.718	20.750	1.838	0.029/0.085	AL-LF	4352RA		
TW/A	2	58.808/59.062	73.486/73.740		2.485		AL-LF	4351AF	<b>A190/2</b> STD	
SE/PB	1	20.996/21.000	23.005/23.020	23.500			BS	66329Y	<b>55-4505</b> SEMI	













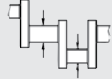

JJ450











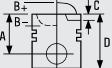
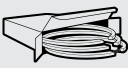

JJ450

<b>1075</b>		 <b>84.00</b>		<b>Petrol</b>					
<b>132 A1.000</b>	4 Cyl.	8.9:1	1756cc	<b>77-82kW (105-112)PS</b>				<b>TD21453</b>	
<b>132 AB.000</b>	4 Cyl.	8.9:1	1756cc	<b>77-82kW (105-112)PS</b>				<b>TD23120</b>	
<b>132 AB.1A.0</b>	4 Cyl.	9:1	1756cc	<b>77-82kW (105-112)PS</b>				<b>TD21456</b>	
<b>132 BB.1A 0</b>	4 Cyl.	9:1	1756cc	<b>77-82kW (105-112)PS</b>				<b>TD21457</b>	
<b>132 C1.000</b>	4 Cyl.	8.9:1	1756cc	<b>77-82kW (105-112)PS</b>				<b>TD19054</b>	<b>397</b>
<b>132 CB.1A</b>	4 Cyl.	9:1	1756cc	<b>77-82kW (105-112)PS</b>				<b>TD21459</b>	

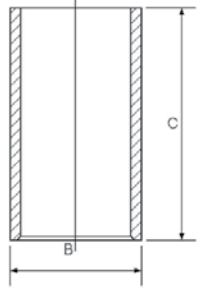
									
BE/PL	4	50.782/50.802	53.897/53.913	19.500	1.537	0.021/0.082	AL-LF	66240RA	<b>01-4175/4</b> STD 0.25 0.50 0.75 1.00
MB/HL 1,2,4,5	4	52.985/53.005	56.717/56.730	20.750	1.841	0.030/0.088	AL-LF	66316RA	<b>H1043/5</b> STD 0.25 0.50 0.75
MB/HL 3	1	52.985/53.005	56.717/56.730	24.250	1.841	0.030/0.088	AL-LF	66317RA	
TW/A	2	59.000/59.250	73.600/73.850		2.362		BS	62037AF	<b>A201/2</b> STD .005
SE/PB	1	21.539/21.641	25.000/25.021	25.100			BS	66649Y	<b>55-4193</b> SEMI
<b>→06/84</b>									
SE/PB	1	21.539/21.641	23.939/23.972	25.100			BS	62039Y	<b>55-4288</b> SEMI
<b>07/84→</b>									

<b>1076</b>		 <b>84.00</b>		<b>Petrol</b>					
<b>132 AC1.000</b>	4 Cyl.	9.8:1	1756cc	<b>87kW (118)PS</b>				<b>TD23121</b>	<b>394</b>

			
	<p><b>08-207600-00</b> STD</p> <p><b>08-207604-00</b> 0.20mm</p> <p><b>08-207606-00</b> 0.40mm</p> <p><b>08-207608-00</b> 0.60mm</p> <p>1.50  CR P</p> <p>2.00  P</p> <p>3.95  CR [15]</p>	<p><b>14-011041-00 D</b></p> <p><b>B 88.06 C 152.00</b></p> 	
	<p><b>08-215300-10</b> STD</p> <p><b>08-215306-10</b> 0.40mm</p> <p><b>08-215308-10</b> 0.60mm</p> <p>02/88→</p> <p>1.50  CR P</p> <p>2.00  P</p> <p>3.95  P</p>		

[15] Steel

[15] Acier









[15] Acciaio

[15] Acero

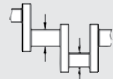
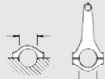
# FIAT GROUP

...Continued





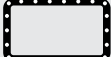
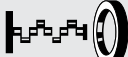
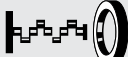
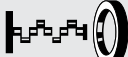



## 1076 84.00 Petrol

									
BE/PL	4	50.782/50.802	53.897/53.913	19.500	1.537	0.021/0.082	AL-LF	66240RA	<b>01-4175/4</b> STD 0.25 0.50 0.75 1.00
MB/HL 1,2,4,5	4	52.985/53.005	56.717/56.730	20.750	1.841	0.030/0.088	AL-LF	66316RA	<b>H1043/5</b> STD 0.25 0.50 0.75
MB/HL 3	1	52.985/53.005	56.717/56.730	24.250	1.841	0.030/0.088	AL-LF	66317RA	
TW/A	2	59.000/59.250	73.600/73.850		2.362		BS	62037AF	<b>A201/2</b> STD .005
SE/PB	1	21.539/21.641	25.000/25.021	25.100			BS	66649Y	<b>55-4193</b> SEMI
→06/84									
SE/PB	1	21.539/21.641	23.939/23.972	25.100			BS	62039Y	<b>55-4288</b> SEMI
07/84 →									

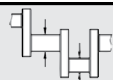
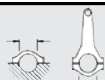
		
		<b>NB818</b>  40.00x56.00x7.00mm, ACM <b>NA5050</b>  70.00x90.00x10.00mm, ACM

## 1077 84.00 Petrol

132 B.000      4 Cyl.      8.9:1      1756cc      79kW (107)PS      TD18854      395

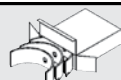
									
BE/PL	4	50.782/50.802	53.897/53.913	19.500	1.537	0.021/0.082	AL-LF	66240RA	<b>01-4175/4</b> STD 0.25 0.50 0.75 1.00
01/75 →									
MB/HL 1,2,4,5	4	52.985/53.005	56.717/56.730	20.750	1.841	0.030/0.088	AL-LF	66316RA	<b>H1043/5</b> STD 0.25 0.50 0.75
MB/HL 3	1	52.985/53.005	56.717/56.730	24.250	1.841	0.030/0.088	AL-LF	66317RA	
TW/A	2	59.000/59.250	73.600/73.850		2.362		BS	62037AF	<b>A201/2</b> STD .005
SE/PB	1	21.539/21.641	25.000/25.021	25.100			BS	66649Y	<b>55-4193</b> SEMI
→06/84									
SE/PB	1	21.539/21.641	23.939/23.972	25.100			BS	62039Y	<b>55-4288</b> SEMI
07/84 →									

<b>1078</b>	<b>84.00</b>	<b>Petrol</b>			
<b>132 B1.000</b>	4 Cyl.	8.9:1	1756cc	<b>77-82kW (105-112)PS</b>	<b>TD21378</b>
<b>132 BB.1A 0</b>	4 Cyl.	9:1	1756cc	<b>77-82kW (105-112)PS</b>	<b>TD22281</b>
<b>134 AS.000</b>	4 Cyl.	8.9:1	1995cc	<b>88kW (120)PS</b>	<b>TD1781 377</b>
<b>828 B7.000</b>	4 Cyl.	9:1	1995cc	<b>99kW (135)PS</b>	<b>TD1800 446</b>

BE/PL	4	50.782/50.802	53.897/53.913	19.500	1.537	0.021/0.082	AL-LF	66240RA	<b>01-4175/4</b> STD 0.25 0.50 0.75 1.00
MB/HL 1,2,4,5	4	52.985/53.005	56.717/56.730	20.750	1.841	0.030/0.088	AL-LF	66316RA	<b>H1043/5</b> STD 0.25 0.50 0.75
MB/HL 3	1	52.985/53.005	56.717/56.730	24.250	1.841	0.030/0.088	AL-LF	66317RA	
TW/A	2	59.000/59.250	73.600/73.850		2.362		BS	62037AF	<b>A201/2</b> STD .005
SE/PB	1	21.539/21.641	25.000/25.021	25.100			BS	66649Y	<b>55-4193</b> SEMI
SE/PB	1	21.539/21.641	23.939/23.972	25.100			BS	62039Y	<b>55-4288</b> SEMI

<b>1079</b>	<b>84.00</b>	<b>Petrol</b>			
<b>132 B1.000</b>	4 Cyl.	8.9:1	1756cc	<b>77-82kW (105-112)PS</b>	<b>TD906 396</b>

	<p><b>08-207600-00</b> STD</p> <p><b>08-207604-00</b> 0.20mm</p> <p><b>08-207606-00</b> 0.40mm</p> <p><b>08-207608-00</b> 0.60mm</p> <p>1.50  CR P</p> <p>2.00  P</p> <p>3.95  CR [15]</p>		
	<p><b>08-215300-10</b> STD</p> <p><b>08-215306-10</b> 0.40mm</p> <p><b>08-215308-10</b> 0.60mm</p> <p>02/88 →</p> <p>1.50  CR P</p> <p>2.00  P</p> <p>3.95  P</p>		

[15] Steel      [15] Acier      [15] Acciaio      [15] Acero

BE/PL	4	50.782/50.802	53.897/53.913	19.500	1.537	0.021/0.082	AL-LF	66240RA	<b>01-4175/4</b> STD 0.25 0.50 0.75 1.00
MB/HL 1,2,4,5	4	52.985/53.005	56.717/56.730	20.750	1.841	0.030/0.088	AL-LF	66316RA	<b>H1043/5</b> STD 0.25 0.50 0.75
MB/HL 3	1	52.985/53.005	56.717/56.730	24.250	1.841	0.030/0.088	AL-LF	66317RA	
TW/A	2	59.000/59.250	73.600/73.850		2.362		BS	62037AF	<b>A201/2</b> STD .005
SE/PB	1	21.539/21.641	25.000/25.021	25.100			BS	66649Y	<b>55-4193</b> SEMI

# FIAT GROUP







## 1080



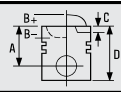
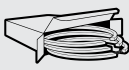



 84.00

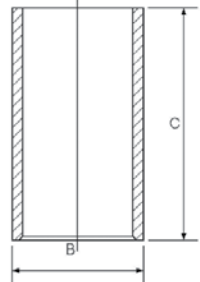

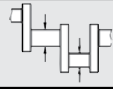
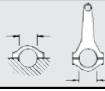

Petrol

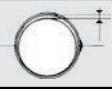

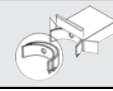
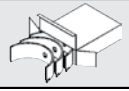
159 A4.000	4 Cyl.	9.5:1	1756cc	74-81kW (101-110)PS	TD1008	398
159 A4.046	4 Cyl.	9.5:1	1756cc	77kW (105)PS	TD1009	399

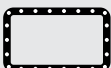
			
	<b>08-142400-00</b> STD <b>08-142406-00</b> 0.40mm  1.50  CK 1.50  P 3.00  P	<b>14-011041-00 D</b> B 88.06 C 152.00  	

									
BE/PL	4	50.792/50.805	53.892/53.910	19.500	1.537	0.010/0.070	BS	1150CP	<b>71-4120/4</b> STD 0.25 0.50
MB/HL 1,2,4,5	4	52.985/53.005	56.717/56.730	20.750	1.841	0.030/0.088	AL-LF	66316RA	<b>H1043/5</b> STD 0.25 0.50 0.75
MB/HL 3	1	52.985/53.005	56.717/56.730	24.250	1.841	0.030/0.088	AL-LF	66317RA	
TW/A	2	59.000/59.250	73.600/73.850		2.362		BS	62037AF	<b>A201/2</b> STD .005
SE/PB	1	28.002/28.010	30.000/30.021	25.250			BS	66649RY	<b>55-4294</b> SEMI

		
	<b>JJ298</b> (Cork)   JJ298	<b>NB742</b>  30.00x43.00x8.00mm, ACM









## 1081

 84.00

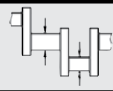
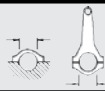
Petrol





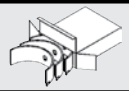













160 A5.000	4 Cyl.	9.9:1	1756cc	100kW (136)PS	TD13669	400
------------	--------	-------	--------	---------------	---------	-----

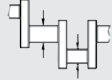
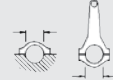

									
BE/PL	4	50.787/50.807	53.901/53.913	19.500	1.534	0.028/0.083	BS	4350CP	<b>71-4157/4</b> STD 0.25 0.50
MB/HL 1,2,4,5	4	52.990/53.010	56.717/56.735	20.750	1.843	0.020/0.080	BS	4128CP	<b>H1084/5</b> STD 0.25 0.50
MB/HL 3	1	52.990/53.010	56.717/56.735	24.250	1.843	0.020/0.080	BS	4129CP	
TW/A	2	59.000/59.250	73.600/73.850		2.362		BS	62037AF	<b>A201/2</b> STD .005
SE/PB	1	21.539/21.641	25.000/25.021	25.100			BS	66649Y	<b>55-4193</b> SEMI





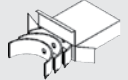





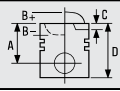
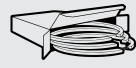



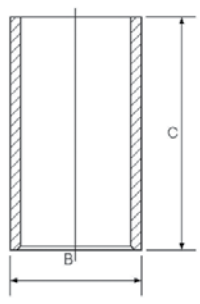

...Continued

<b>1081</b>	 <b>84.00</b>	<b>Petrol</b>
		
	JJ413	<b>NB742</b>  30.00x43.00x8.00mm, ACM <b>NB732</b>  74.00x90.00x10.00mm, FPM
		
	JJ413	

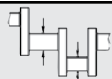
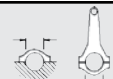

<b>1082</b>	 <b>84.00</b>	<b>Petrol</b>							
<b>828 A1.000</b>	4 Cyl.	1756cc	<b>81kW (110)PS</b>	<b>TD1792</b>					
									
BE/PL	4	50.782/50.802	53.897/53.913	19.500	1.537	0.021/0.082	AL-LF	66240RA	<b>01-4175/4</b> STD 0.25 0.50 0.75 1.00
MB/HL 1,2,4,5	4	52.985/53.005	56.717/56.730	20.750	1.841	0.030/0.088	AL-LF	66316RA	<b>H1043/5</b> STD 0.25 0.50 0.75
MB/HL 3	1	52.985/53.005	56.717/56.730	24.250	1.841	0.030/0.088	AL-LF	66317RA	
TW/A	2	59.000/59.250	73.600/73.850		2.362		BS	62037AF	<b>A201/2</b> STD .005
SE/PB	1	21.539/21.641	23.939/23.972	25.100			BS	62039Y	<b>55-4288</b> SEMI



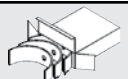

<b>1083</b>	 <b>84.00</b>	<b>Petrol</b>				
<b>835 A2.000</b>	4 Cyl.	9.5:1	1756cc	<b>80kW (108)PS</b>	<b>TD1845</b>	<b>401</b>
<b>835 C2.000</b>	4 Cyl.	9.5:1	1756cc	<b>76kW (103)PS</b>	<b>TD4612</b>	<b>404</b>





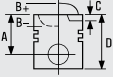

			
	<b>08-142400-00</b> STD <b>08-142406-00</b> 0.40mm  1.50  CK 1.50  P 3.00  P	<b>14-011041-00 D</b> <b>B 88.06 C 152.00</b>  	

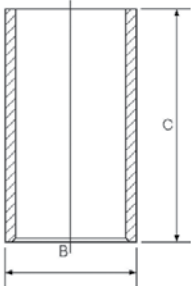

									
BE/PL	4	50.792/50.805	53.892/53.910	19.500	1.537	0.010/0.070	BS	1150CP	<b>71-4120/4</b> STD 0.25 0.50
MB/HL 1,2,4,5	4	52.985/53.005	56.717/56.730	20.750	1.841	0.030/0.088	AL-LF	66316RA	<b>H1043/5</b> STD 0.25 0.50 0.75
MB/HL 3	1	52.985/53.005	56.717/56.730	24.250	1.841	0.030/0.088	AL-LF	66317RA	
TW/A	2	59.000/59.250	73.600/73.850		2.362		BS	62037AF	<b>A201/2</b> STD .005
SE/PB	1	21.539/21.641	25.000/25.021	25.100			BS	66649Y	<b>55-4193</b> SEMI

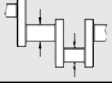
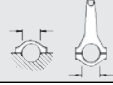

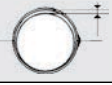

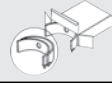
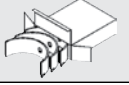

# FIAT GROUP

<b>1084</b>	 <b>84.00</b>	<b>Petrol</b>				
<b>835 A2.046</b>	4 Cyl.	9.5:1	1756cc	<b>74-77kW (101-105)PS</b>	<b>TD1844</b>	<b>402</b>
<b>835 C4.000</b>	4 Cyl.	9.5:1	1756cc	<b>66kW (90)PS</b>	<b>TD5433</b>	<b>405</b>
<b>836 A5.000</b>	4 Cyl.	10:1	1756cc	<b>74kW (101)PS</b>	<b>TD4615</b>	<b>408</b>
<b>836 C4.000</b>	4 Cyl.		1756cc	<b>66kW (90)PS</b>	<b>TD5434</b>	<b>405</b>

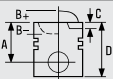
			
		<b>14-011041-00 D</b> <b>B 88.06 C 152.00</b>	
			





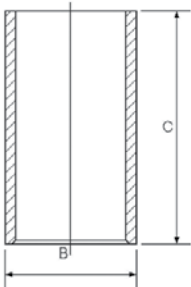



									
BE/PL	4	50.792/50.805	53.892/53.910	19.500	1.537	0.010/0.070	BS	1150CP	<b>71-4120/4</b> STD 0.25 0.50
MB/HL 1,2,4,5	4	52.985/53.005	56.717/56.730	20.750	1.841	0.030/0.088	AL-LF	66316RA	<b>H1043/5</b> STD 0.25 0.50 0.75
MB/HL 3	1	52.985/53.005	56.717/56.730	24.250	1.841	0.030/0.088	AL-LF	66317RA	
TW/A	2	59.000/59.250	73.600/73.850		2.362		BS	62037AF	<b>A201/2</b> STD .005
SE/PB	1	21.539/21.641	25.000/25.021	25.100			BS	66649Y	<b>55-4193</b> SEMI



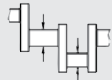
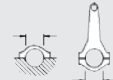



<b>1085</b>	 <b>84.00</b>	<b>Petrol</b>				
<b>835 C2.000</b>	4 Cyl.	9.5:1	1756cc	<b>76kW (103)PS</b>	<b>TD1068</b>	<b>403</b>



			
	<b>08-142400-00</b> STD <b>08-142406-00</b> 0.40mm  1.50  CK 1.50  P 3.00  P	<b>14-011041-00 D</b> <b>B 88.06 C 152.00</b>	
			

...Continued





**1085**  **84.00** **Petrol**





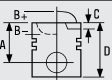

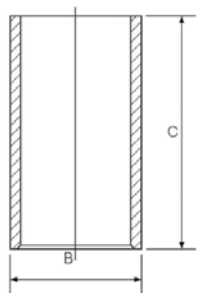

									
BE/PL	4	50.792/50.805	53.892/53.910	19.500	1.537	0.010/0.070	BS	1150CP	<b>71-4120/4</b> STD 0.25 0.50
MB/HL 1,2,4,5	4	52.985/53.005	56.717/56.730	20.750	1.841	0.030/0.088	AL-LF	66316RA	<b>H1043/5</b> STD 0.25 0.50 0.75
MB/HL 3	1	52.985/53.005	56.717/56.730	24.250	1.841	0.030/0.088	AL-LF	66317RA	
TW/A	2	59.000/59.250	73.600/73.850		2.362		BS	62037AF	<b>A201/2</b> STD .005
SE/PB	1	28.002/28.010	30.000/30.021	25.250			BS	66649RY	<b>55-4294</b> SEMI

		
	JJ413	<b>NB742</b>  30.00x43.00x8.00mm, ACM <b>NB825</b>  30.00x43.00x8.00mm, FPM <b>NB732</b>  74.00x90.00x10.00mm, FPM
		
	JJ413	

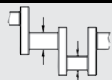
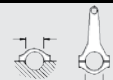
**1086**  **84.00** **Petrol** 

835 C4.000      4 Cyl.      1756cc      66kW (90)PS      TD1069      406

			
		<b>14-011041-00 D</b> <b>B 88.06    C 152.00</b>	
			

									
BE/PL	4	50.792/50.805	53.892/53.910	19.500	1.537	0.010/0.070	BS	1150CP	<b>71-4120/4</b> STD 0.25 0.50
MB/HL 1,2,4,5	4	52.985/53.005	56.717/56.730	20.750	1.841	0.030/0.088	AL-LF	66316RA	<b>H1043/5</b> STD 0.25 0.50 0.75
MB/HL 3	1	52.985/53.005	56.717/56.730	24.250	1.841	0.030/0.088	AL-LF	66317RA	
TW/A	2	59.000/59.250	73.600/73.850		2.362		BS	62037AF	<b>A201/2</b> STD .005
SE/PB	1	28.002/28.010	30.000/30.021	25.250			BS	66649RY	<b>55-4294</b> SEMI

# FIAT GROUP

<b>1087</b>	<b>84.00</b>	<b>Petrol</b>	
<b>835 C5.000</b>	4 Cyl.	9.5:1	1756cc
			<b>66kW (90)PS</b>
			<b>TD1847 407</b>

BE/PL	4	50.792/50.805	53.892/53.910	19.500	1.537	0.010/0.070	BS	1150CP	<b>71-4120/4</b> STD 0.25 0.50	
MB/HL 1,2,4,5	4	52.985/53.005	56.717/56.730	20.750	1.841	0.030/0.088	AL-LF	66316RA	<b>H1043/5</b> STD 0.25 0.50 0.75	
MB/HL 3	1	52.985/53.005	56.717/56.730	24.250	1.841	0.030/0.088	AL-LF	66317RA		
TW/A	2	59.000/59.250	73.600/73.850		2.362		BS	62037AF	<b>A201/2</b> STD .005	
SE/PB	1	21.539/21.641	25.000/25.021	25.100			BS	66649Y	<b>55-4193</b> SEMI	

--	--	--

JH111

**NB825** 30.00x43.00x8.00mm, FPM  
**NB732** 74.00x90.00x10.00mm, FPM



JH111

<b>1088</b>	<b>84.00</b>	<b>Petrol</b>	
<b>836 A2.046</b>	4 Cyl.	1756cc	
			<b>74kW (101)PS</b>
			<b>TD4613</b>









BE/PL	4	50.792/50.805	53.892/53.910	19.500	1.537	0.010/0.070	BS	1150CP	<b>71-4120/4</b> STD 0.25 0.50	
MB/HL 1,2,4,5	4	52.985/53.005	56.717/56.730	20.750	1.841	0.030/0.088	AL-LF	66316RA	<b>H1043/5</b> STD 0.25 0.50 0.75	
MB/HL 3	1	52.985/53.005	56.717/56.730	24.250	1.841	0.030/0.088	AL-LF	66317RA		
TW/A	2	59.000/59.250	73.600/73.850		2.362		BS	62037AF	<b>A201/2</b> STD .005	
SE/PB	1	21.539/21.641	25.000/25.021	25.100			BS	66649Y	<b>55-4193</b> SEMI	



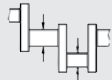
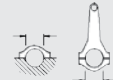



<b>1089</b>	<b>84.00</b>	<b>Petrol</b>	
<b>836 A5.000</b>	4 Cyl.	1756cc	
			<b>71-74kW (97-101)PS</b>
			<b>TD892 409</b>

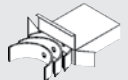

		<b>14-011041-00 D</b> B 88.06 C 152.00	

...Continued





**1089**  **84.00** **Petrol**





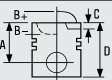

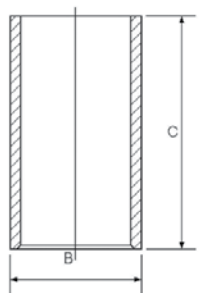

									
BE/PL	4	50.792/50.805	53.892/53.910	19.500	1.537	0.010/0.070	BS	1150CP	<b>71-4120/4</b> STD 0.25 0.50
MB/HL 1,2,4,5	4	52.985/53.005	56.717/56.730	20.750	1.841	0.030/0.088	AL-LF	66316RA	<b>H1043/5</b> STD 0.25 0.50 0.75
MB/HL 3	1	52.985/53.005	56.717/56.730	24.250	1.841	0.030/0.088	AL-LF	66317RA	
TW/A	2	59.000/59.250	73.600/73.850		2.362		BS	62037AF	<b>A201/2</b> STD .005
SE/PB	1	28.002/28.010	30.000/30.021	25.250			BS	66649RY	<b>55-4294</b> SEMI

		
	JJ413	<b>NB742</b>  30.00x43.00x8.00mm, ACM <b>NB825</b>  30.00x43.00x8.00mm, FPM <b>NB732</b>  74.00x90.00x10.00mm, FPM
		
	JJ413	

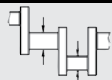
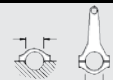
**1090**  **84.00** **Petrol** 





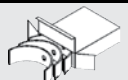

836 A6.000      4 Cyl.      9.6:1      1756cc      66kW (90)PS      TD11918      410





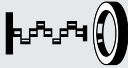







			
		<b>14-011041-00 D</b> <b>B 88.06    C 152.00</b>	
			

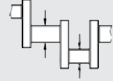













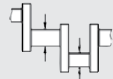

									
BE/PL	4	50.792/50.805	53.892/53.910	19.500	1.537	0.010/0.070	BS	1150CP	<b>71-4120/4</b> STD 0.25 0.50
MB/HL 1,2,4,5	4	52.985/53.005	56.717/56.730	20.750	1.841	0.030/0.088	AL-LF	66316RA	<b>H1043/5</b> STD 0.25 0.50 0.75
MB/HL 3	1	52.985/53.005	56.717/56.730	24.250	1.841	0.030/0.088	AL-LF	66317RA	
TW/A	2	59.000/59.250	73.600/73.850		2.362		BS	62037AF	<b>A201/2</b> STD .005
SE/PB	1	21.539/21.641	25.000/25.021	25.100			BS	66649Y	<b>55-4193</b> SEMI



# FIAT GROUP



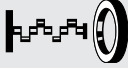



...Continued



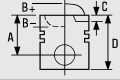





<b>1090</b>	 <b>84.00</b>	<b>Petrol</b>
		
	<b>JJ413</b>	<b>NB742</b>  30.00x43.00x8.00mm, ACM <b>NB732</b>  74.00x90.00x10.00mm, FPM
		
	<b>JJ413</b>	



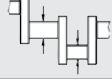
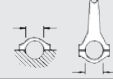

<b>1091</b>	 <b>84.00</b>	<b>Petrol</b>							
<b>836 A6.000</b>	4 Cyl.	9.6:1	1756cc	<b>66kW (90)PS</b>	<b>TD18890</b>	<b>411</b>			
									
BE/PL	4	50.792/50.805	53.892/53.910	19.500	1.537	0.010/0.070	BS	1150CP	<b>71-4120/4</b> STD 0.25 0.50
MB/HL 1,2,4,5	4	52.985/53.005	56.717/56.730	20.750	1.841	0.030/0.088	AL-LF	66316RA	<b>H1043/5</b> STD 0.25 0.50 0.75
MB/HL 3	1	52.985/53.005	56.717/56.730	24.250	1.841	0.030/0.088	AL-LF	66317RA	
TW/A	2	59.000/59.250	73.600/73.850		2.362		BS	62037AF	<b>A201/2</b> STD .005
SE/PB	1	28.002/28.010	30.000/30.021	25.250			BS	66649RY	<b>55-4294</b> SEMI

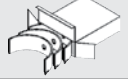

<b>1092</b>	 <b>84.00</b>	<b>Petrol</b>							
<b>AR 67402</b>	4 Cyl.		1756cc	<b>77kW (105)PS</b>	<b>TD5071</b>	<b>412</b>			
									
BE/PL	4	49.988/49.998	53.695/53.708	23.440	1.838	0.021/0.069	BS	60010CP	<b>71-4168/4</b> STD 0.25 0.50
MB/HL 1,3,5	3	59.960/59.973	63.657/63.676	25.530	1.837	0.020/0.067	BS	60011CP	<b>H1030/5</b> STD 0.25 0.50
MB/HL 2,4	2	59.960/59.973	63.657/63.676	18.360	1.837	0.020/0.067	BS	60012CP	
TW/A	4	65.786/66.040	82.423/82.677		2.362		AL-LF	2777AF	<b>A178/4</b> STD
SE/PB	1	21.994/22.000	25.120/25.146	23.720			BS	60014X	<b>55-4280</b> SEMI
									
									<b>NF722</b>  35.00x50.00x10.00mm, MVQ





<b>1093</b>	 <b>84.00</b>	<b>Petrol</b>				
<b>AR 67101</b>	4 Cyl.	1773cc	<b>93-95kW (126-129)PS</b>	<b>TD133</b>	<b>412</b>	
<b>AR 67102</b>	4 Cyl.	10:1	1773cc	<b>93kW (127)PS</b>	<b>TD5311</b>	<b>412</b>

			
	<b>08-110200-00</b> STD  1.50  CR P 1.50  P 3.50  P		

									
BE/PL	4	49.988/49.998	53.695/53.708	23.440	1.838	0.021/0.069	BS	60010CP	<b>71-4168/4</b> STD 0.25 0.50
MB/HL 1,3,5	3	59.960/59.973	63.657/63.676	25.530	1.837	0.020/0.067	BS	60011CP	<b>H1030/5</b> STD 0.25 0.50
MB/HL 2,4	2	59.960/59.973	63.657/63.676	18.360	1.837	0.020/0.067	BS	60012CP	
TW/A	4	65.786/66.040	82.423/82.677		2.362		AL-LF	2777AF	<b>A178/4</b> STD
SE/PB	1	21.994/22.000	25.120/25.146	23.720			BS	60014X	<b>55-4280</b> SEMI

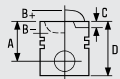
		
		<b>NF722</b>  35.00x50.00x10.00mm, MVQ

<b>1094</b>	 <b>84.00</b>	<b>Petrol</b>				
<b>169 B</b>	4 Cyl.	7.5:1	1796cc	<b>49kW (67)PS</b>	<b>TD12750</b>	<b>413</b>

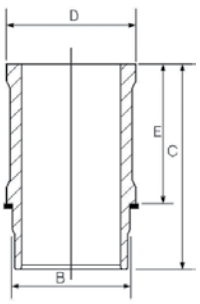
			
		<b>14-606670-00 WH [16]</b> <b>B 93.00 C 136.20 D 99.20 E 90.01</b>  	

[16] Use also: 1 NB O-Ring HR566

[16] A utiliser aussi: 1 joint toriques HR566









[16] Usare anche: 1 NB O-Ring HR566



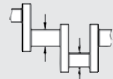
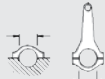

[16] Utilizar también: 1 NB junta toricas HR566

# FIAT GROUP

...Continued









## 1094 84.00 Petrol

									
BE/PL	4	49.975/49.991	53.655/53.674	23.400	1.818	0.030/0.080	AL-LF	2865RA	<b>01-4558/4</b> STD 0.30 0.50 0.80 1.00  <b>H1240/5</b> STD 0.30 0.50 0.80             <b>H1241/5</b> STD 0.30 0.50 0.80             <b>A199/4</b> STD 0.10 0.15 0.20  <b>55-4134</b> SEMI
MB/HL 1	1	59.401/59.416	63.227/63.246	29.500	1.888	0.040/0.080	AL-LF	2866RA	
MB/HL 2	1	58.548/58.573	62.384/62.403	21.500	1.888	0.040/0.080	AL-LF	61902RA	
MB/HL 3	1	57.174/57.189	61.000/61.019	29.500	1.888	0.040/0.080	AL-LF	61903RA	
MB/HL 4	1	56.140/56.165	59.976/59.995	21.500	1.888	0.040/0.080	AL-LF	61903RAA	
MB/HL 5	1	54.905/54.920	58.731/58.750	29.350	1.888	0.040/0.080	AL-LF	61904RA	
MB/HL 5	1	54.905/54.920	58.731/58.750	29.350	1.900	0.040/0.080	AL-LF	66696RA	
MB/HL 4	1	56.140/56.165	59.976/59.995	21.500	1.900	0.040/0.080	AL-LF	66697RA	
MB/HL 3	1	57.174/57.189	61.000/61.019	29.500	1.900	0.040/0.080	AL-LF	66698RA	
MB/HL 2	1	58.548/58.573	62.384/62.403	21.500	1.900	0.040/0.080	AL-LF	66699RA	
MB/HL 1	1	59.401/59.416	63.227/63.246	29.500	1.900	0.040/0.080	AL-LF	66699RAA	
TW/A	4	61.400/61.650	72.550/72.800		2.330		AL-LF	61904BF	
SE/PB	1	22.700/22.850	24.350/24.383	27.000			BS	2514X	

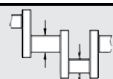
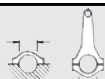

		
		NA5191  42.00x62.00x7.00mm, PTFE



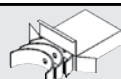





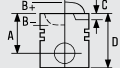
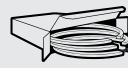

## 1095 84.00 Petrol

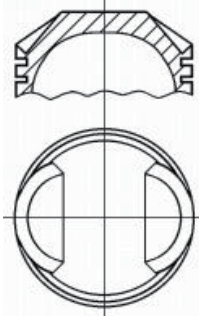
**XM7T** 4 Cyl. 7.5:1 1796cc 50-51kW (68-69)PS **TD28853**



									
BE/PL	4	49.975/49.991	53.655/53.674	23.400	1.818	0.030/0.080	AL-LF	2865RA	<b>01-4558/4</b> STD 0.30 0.50 0.80 1.00  <b>H1241/5</b> STD 0.30 0.50 0.80
MB/HL 5	1	54.905/54.920	58.731/58.750	29.350	1.900	0.040/0.080	AL-LF	66696RA	
MB/HL 4	1	56.140/56.165	59.976/59.995	21.500	1.900	0.040/0.080	AL-LF	66697RA	
MB/HL 3	1	57.174/57.189	61.000/61.019	29.500	1.900	0.040/0.080	AL-LF	66698RA	
MB/HL 2	1	58.548/58.573	62.384/62.403	21.500	1.900	0.040/0.080	AL-LF	66699RA	
MB/HL 1	1	59.401/59.416	63.227/63.246	29.500	1.900	0.040/0.080	AL-LF	66699RAA	



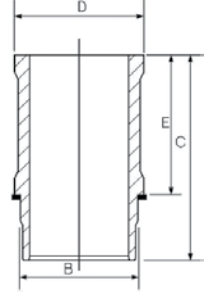

**1096**  **84.00** **Petrol**   
**116 (33)** 4 Cyl. 9:1 1962cc **94kW (128)PS** **FM3549**





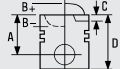
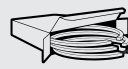

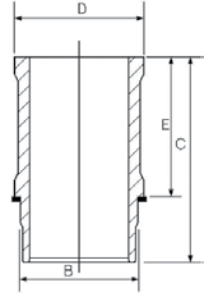





			
<p><b>87-107100-30</b> STD</p>  <p><b>A</b> 32.75  <b>B-</b> 14.75  <b>D</b> 81.00   22x71</p>	<p><b>08-107100-00</b> STD</p> <p>1.50  CR P          1.75  P          4.50  P</p> <p><b>08-107100-10</b> STD</p> <p>1.50  CR P          1.75  P          4.00  P</p>	<p><b>15-632000-00 WH</b> [9]  <b>B</b> 89.00 <b>C</b> 152.00 <b>D</b> 98.00 <b>E</b> 107.50</p> 	<p><b>89-107100-30</b>          87-107100-30 +          15-632000-00</p>





[9] Includes seals [9] Inclut des joints [9] Comprende le guarnizioni [9] Incluye los sellos

**1097**  **84.00** **Petrol**   
**AR 00512** 4 Cyl. 9:1 1962cc **96kW (131)PS** **TD75 414**



			
		<p><b>15-632000-00 WH</b> [9]  <b>B</b> 89.00 <b>C</b> 152.00 <b>D</b> 98.00 <b>E</b> 107.50</p> 	

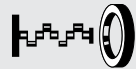







[9] Includes seals [9] Inclut des joints [9] Comprende le guarnizioni [9] Incluye los sellos



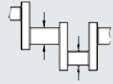
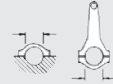

												
BE/PL	4	49.988/49.998	53.695/53.708	23.440	1.838	0.021/0.069	BS	60010CP	<b>71-4168/4</b> STD 0.25 0.50			
MB/HL 1,3,5	3	59.960/59.973	63.657/63.676	25.530	1.837	0.020/0.067	BS	60011CP	<b>H1030/5</b> STD 0.25 0.50			
MB/HL 2,4	2	59.960/59.973	63.657/63.676	18.360	1.837	0.020/0.067	BS	60012CP				
TW/A	4	65.786/66.040	82.423/82.677		2.362		AL-LF	2777AF	<b>A178/4</b> STD			
SE/PB	1	21.994/22.000	25.120/25.146	23.720			BS	60014X	<b>55-4280</b> SEMI			



		 <p><b>NA5066</b>  35.00x50.00x10.00mm, ACM</p>
---	---	---









# FIAT GROUP

<b>1098</b>		 <b>84.00</b>	<b>Petrol</b>				
AR 00515	4 Cyl.	1962cc	<b>92-93kW</b> (125-126)PS	<b>TD21</b>	<b>415</b>		
AR 01590	4 Cyl.	1962cc	<b>93kW</b> (126)PS	<b>TD31</b>	<b>418</b>		
AR 01615	4 Cyl.	1962cc	<b>81kW</b> (110)PS	<b>TD21716</b>			
AR 01713	4 Cyl.	1962cc	<b>94-97kW</b> (128-132)PS	<b>TD41</b>	<b>421</b>		
AR 10527	4 Cyl.	1962cc	<b>96kW</b> (131)PS	<b>TD10127</b>	<b>425</b>		

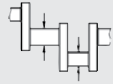
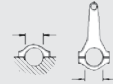
									
BE/PL	4	49.988/49.998	53.695/53.708	23.440	1.838	0.021/0.069	BS	60010CP	<b>71-4168/4</b> STD 0.25 0.50
MB/HL 1,3,5	3	59.960/59.973	63.657/63.676	25.530	1.837	0.020/0.067	BS	60011CP	<b>H1030/5</b> STD 0.25 0.50
MB/HL 2,4	2	59.960/59.973	63.657/63.676	18.360	1.837	0.020/0.067	BS	60012CP	
TW/A	4	65.786/66.040	82.423/82.677		2.362		AL-LF	2777AF	<b>A178/4</b> STD
SE/PB	1	21.994/22.000	25.120/25.146	23.720			BS	60014X	<b>55-4280</b> SEMI

		
		<b>NA5066</b>  35.00x50.00x10.00mm, ACM

<b>1099</b>		 <b>84.00</b>	<b>Petrol</b>				
AR 01212	4 Cyl.	1962cc	<b>94kW</b> (128)PS	<b>TD27</b>			
AR 11634	4 Cyl.	10:1	1962cc	<b>82kW</b> (112)PS	<b>TD68</b>		
AR 11655	4 Cyl.	10:1	1962cc	<b>94-109kW</b> (128-148)PS	<b>TD23342</b>		

									
BE/PL	4	49.988/49.998	53.695/53.708	23.440	1.838	0.021/0.069	BS	60010CP	<b>71-4168/4</b> STD 0.25 0.50
MB/HL 1,3,5	3	59.960/59.973	63.657/63.676	25.530	1.837	0.020/0.067	BS	60011CP	<b>H1030/5</b> STD 0.25 0.50
MB/HL 2,4	2	59.960/59.973	63.657/63.676	18.360	1.837	0.020/0.067	BS	60012CP	
TW/A	4	65.786/66.040	82.423/82.677		2.362		AL-LF	2777AF	<b>A178/4</b> STD
SE/PB	1	21.994/22.000	25.120/25.146	23.720			BS	60014X	<b>55-4280</b> SEMI

## 1100

### 84.00

### Petrol



AR 01544

4 Cyl.

1962cc

85kW (116)PS

TD28

416

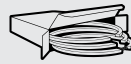
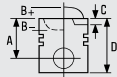

**15-632000-00 WH [9]**  
**B 89.00 C 152.00 D 98.00 E 107.50**

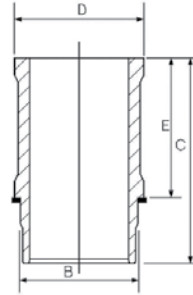

[9] Includes seals

[9] Inclut des joints

[9] Comprende le guarnizioni

[9] Incluye los sellos

BE/PL	4	49.988/49.998	53.695/53.708	23.440	1.838	0.021/0.069	BS	60010CP	<b>71-4168/4</b> STD 0.25 0.50
MB/HL 1,3,5	3	59.960/59.973	63.657/63.676	25.530	1.837	0.020/0.067	BS	60011CP	<b>H1030/5</b> STD 0.25 0.50
MB/HL 2,4	2	59.960/59.973	63.657/63.676	18.360	1.837	0.020/0.067	BS	60012CP	
TW/A	4	65.786/66.040	82.423/82.677		2.362		AL-LF	2777AF	<b>A178/4</b> STD
SE/PB	1	21.994/22.000	25.120/25.146	23.720			BS	60014X	<b>55-4280</b> SEMI



JJ452  
(MVQ)  
KV086

NA5066 ■ 35.00x50.00x10.00mm, ACM



JJ452

KV086





## 1101

 84.00



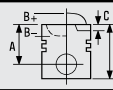
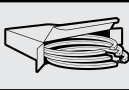

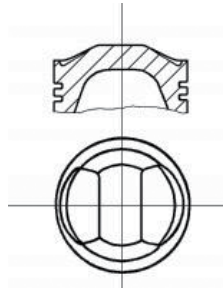
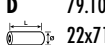

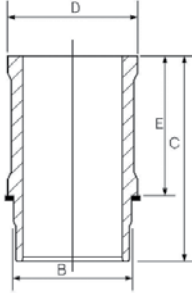

Petrol



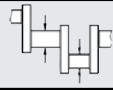



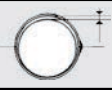

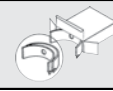
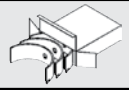
AR 01588      4 Cyl.      1962cc      88kW (120)PS      TD30      417

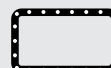







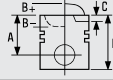

			
<p><b>87-110200-40</b>      STD</p>  <p><b>A</b> 32.75 <b>B-</b> 12.85 <b>D</b> 79.10  22x71</p>	<p><b>08-110200-00</b>      STD</p>  <p>1.50 CR P 1.50 P 3.50 P</p>	<p><b>15-632000-00 WH</b> [9] <b>B</b> 89.00    <b>C</b> 152.00    <b>D</b> 98.00    <b>E</b> 107.50</p> 	<p><b>89-110200-40</b> 87-110200-40 + 15-632000-00</p>

[9] Includes seals      [9] Inclut des joints      [9] Comprende le guarnizioni      [9] Incluye los sellos



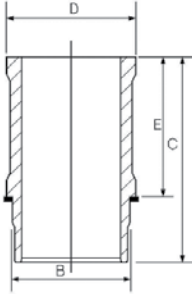





									
BE/PL	4	49.988/49.998	53.695/53.708	23.440	1.838	0.021/0.069	BS	60010CP	<b>71-4168/4</b> STD 0.25 0.50
MB/HL 1,3,5	3	59.960/59.973	63.657/63.676	25.530	1.837	0.020/0.067	BS	60011CP	<b>H1030/5</b> STD 0.25 0.50
MB/HL 2,4	2	59.960/59.973	63.657/63.676	18.360	1.837	0.020/0.067	BS	60012CP	
TW/A	4	65.786/66.040	82.423/82.677		2.362		AL-LF	2777AF	<b>A178/4</b> STD
SE/PB	1	21.994/22.000	25.120/25.146	23.720			BS	60014X	<b>55-4280</b> SEMI



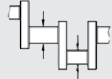
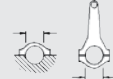

		
	<p><b>JJ452</b> (MVQ) <b>KV086</b></p>  <p><b>JJ452</b>      <b>KV086</b></p>	<p><b>NA5066</b>  35.00x50.00x10.00mm, ACM</p>



<b>1102</b>	 <b>84.00</b>	<b>Petrol</b>	
AR 01623	4 Cyl.	1962cc	89-90kW (121-122)PS
AR 11671	4 Cyl.	10:1 1962cc	96kW (131)PS
			TD34 <b>419</b>
			TD70 <b>425</b>











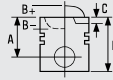

			
	<b>08-107100-00</b> STD 1.50  CR P 1.75  P 4.50  P	<b>15-632000-00 WH [9]</b> <b>B 89.00 C 152.00 D 98.00 E 107.50</b> 	
	<b>08-107100-10</b> STD 1.50  CR P 1.75  P 4.00  P		

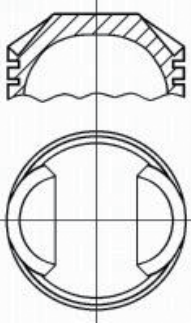
[9] Includes seals [9] Inclut des joints [9] Comprende le guarnizioni [9] Incluye los sellos

									
BE/PL	4	49.988/49.998	53.695/53.708	23.440	1.838	0.021/0.069	BS	60010CP	<b>71-4168/4</b> STD 0.25 0.50
MB/HL 1,3,5	3	59.960/59.973	63.657/63.676	25.530	1.837	0.020/0.067	BS	60011CP	<b>H1030/5</b> STD 0.25 0.50
MB/HL 2,4	2	59.960/59.973	63.657/63.676	18.360	1.837	0.020/0.067	BS	60012CP	
TW/A	4	65.786/66.040	82.423/82.677		2.362		AL-LF	2777AF	<b>A178/4</b> STD
SE/PB	1	21.994/22.000	25.120/25.146	23.720			BS	60014X	<b>55-4280</b> SEMI

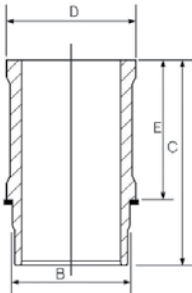
		
		<b>NA5066</b>  35.00x50.00x10.00mm, ACM













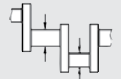

<b>1103</b>	 <b>84.00</b>	<b>Petrol</b>	
AR 01655	4 Cyl.	1962cc	96kW (131)PS
AR 06212	4 Cyl.	9.1:1 1962cc	94-96kW (128-131)PS
			TD37 <b>420</b>
			TD57 <b>421</b>





			
<b>87-107100-40</b> STD  <b>A 33.20</b> <b>B- 18.80</b> <b>D 85.50</b>  22x71	<b>08-107100-10</b> STD 1.50  CR P 1.75  P 4.00  P	<b>15-632000-00 WH [9]</b> <b>B 89.00 C 152.00 D 98.00 E 107.50</b> 	<b>89-107100-40</b> 87-107100-40 + 15-632000-00
	<b>08-107100-00</b> STD 1.50  CR P 1.75  P 4.50  P		

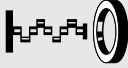





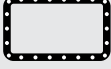



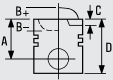

[9] Includes seals [9] Inclut des joints [9] Comprende le guarnizioni [9] Incluye los sellos

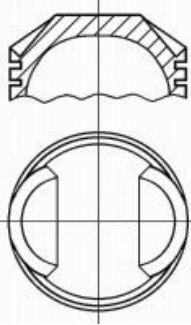
# FIAT GROUP

...Continued

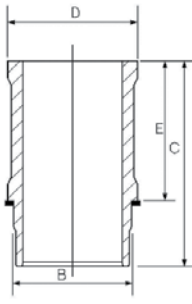







<b>1103</b>		 <b>84.00</b>	<b>Petrol</b>							
										
BE/PL	4	49.988/49.998	53.695/53.708	23.440	1.838	0.021/0.069	BS	60010CP	<b>71-4168/4</b> STD 0.25 0.50	
MB/HL 1,3,5	3	59.960/59.973	63.657/63.676	25.530	1.837	0.020/0.067	BS	60011CP	<b>H1030/5</b> STD 0.25 0.50	
MB/HL 2,4	2	59.960/59.973	63.657/63.676	18.360	1.837	0.020/0.067	BS	60012CP		
TW/A	4	65.786/66.040	82.423/82.677		2.362		AL-LF	2777AF	<b>A178/4</b> STD	
SE/PB	1	21.994/22.000	25.120/25.146	23.720			BS	60014X	<b>55-4280</b> SEMI	
										
<b>NA5066</b>  35.00x50.00x10.00mm, ACM										

<b>1104</b>		 <b>84.00</b>	<b>Petrol</b>							
<b>AR 01699</b>	4 Cyl.	1962cc	<b>125kW (170)PS</b>	<b>Turbocharged</b>				<b>TD40</b>		
<b>AR 11642</b>	4 Cyl.	1962cc	<b>111kW (151)PS</b>					<b>TD69</b>	<b>426</b>	
										
<b>NA5066</b>  35.00x50.00x10.00mm, ACM										

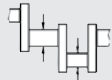
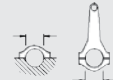
<b>1105</b>		 <b>84.00</b>	<b>Petrol</b>								
<b>AR 06166</b>	4 Cyl.	10:1	1962cc	<b>107kW (146)PS</b>					<b>TD53</b>	<b>422</b>	
											
<b>87-110200-30</b>	STD		<b>08-110200-00</b>	STD		<b>15-632000-00 WH [9]</b>	B 89.00	C 152.00	D 98.00	E 107.50	
A 33.75			1.50		CR P						<b>89-110200-30</b>
B+ 1.25			1.50		P						87-110200-30 +
D 67.50			3.50		P						15-632000-00
 22x71											
[9] Includes seals	[9] Inclut des joints	[9] Comprende le guarnizioni	[9] Incluye los sellos								

...Continued

**1105**  **84.00** **Petrol**

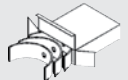

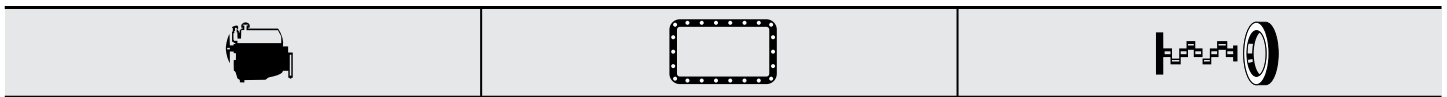
									
BE/PL	4	49.988/49.998	53.695/53.708	23.440	1.838	0.021/0.069	BS	60010CP	<b>71-4168/4</b> STD 0.25 0.50
MB/HL 1,3,5	3	59.960/59.973	63.657/63.676	25.530	1.837	0.020/0.067	BS	60011CP	<b>H1030/5</b> STD 0.25 0.50
MB/HL 2,4	2	59.960/59.973	63.657/63.676	18.360	1.837	0.020/0.067	BS	60012CP	
TW/A	4	65.786/66.040	82.423/82.677		2.362		AL-LF	2777AF	<b>A178/4</b> STD
SE/PB	1	21.994/22.000	25.120/25.146	23.720			BS	60014X	<b>55-4280</b> SEMI





**JJ452** (MVQ) **NA5066** 35.00x50.00x10.00mm, ACM







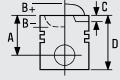
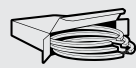

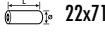
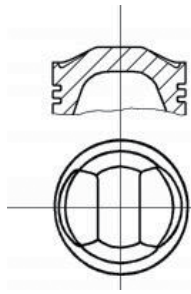
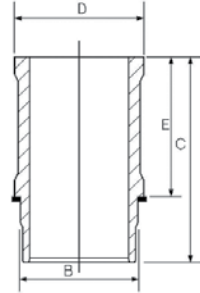

JJ452

**1106**  **84.00** **Petrol** 

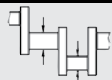
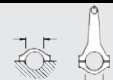
AR 06224 4 Cyl. 1962cc 107-109kW (146-148)PS TD58 422

			
<b>87-110200-40</b> STD	<b>08-110200-00</b> STD	<b>15-632000-00 WH [9]</b> B 89.00 C 152.00 D 98.00 E 107.50	<b>89-110200-40</b> 87-110200-40 + 15-632000-00
A 32.75 B- 12.85 D 79.10  22x71	 1.50 CR P 1.50 P 3.50 P		

[9] Includes seals [9] Inclut des joints [9] Comprende le guarnizioni [9] Incluye los sellos

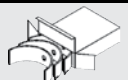
									
BE/PL	4	49.988/49.998	53.695/53.708	23.440	1.838	0.021/0.069	BS	60010CP	<b>71-4168/4</b> STD 0.25 0.50
MB/HL 1,3,5	3	59.960/59.973	63.657/63.676	25.530	1.837	0.020/0.067	BS	60011CP	<b>H1030/5</b> STD 0.25 0.50
MB/HL 2,4	2	59.960/59.973	63.657/63.676	18.360	1.837	0.020/0.067	BS	60012CP	
TW/A	4	65.786/66.040	82.423/82.677		2.362		AL-LF	2777AF	<b>A178/4</b> STD
SE/PB	1	21.994/22.000	25.120/25.146	23.720			BS	60014X	<b>55-4280</b> SEMI

### 1106

**84.00**
**Petrol**

**JJ452**  
(MVQ)

**NA5066** 35.00x50.00x10.00mm, ACM

**JJ452**

### 1107

**84.00**
**Petrol**

<b>AR 10512</b>	4 Cyl.	10:1	1962cc	<b>96kW</b> (131)PS	<b>TD5351</b>	<b>423</b>
<b>AR 11633</b>	4 Cyl.	9:1	1962cc	<b>82-96kW</b> (112-131)PS	<b>TD22398</b>	
<b>AR 19510</b>	4 Cyl.	10:1	1962cc	<b>104-109kW</b> (142-148)PS	<b>TD23344</b>	

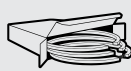
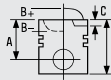
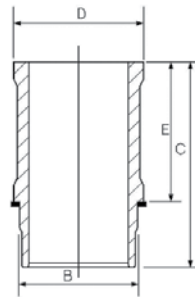
**15-632000-00 WH** [9]  
**B 89.00 C 152.00 D 98.00 E 107.50**

[9] Includes seals



[9] Inclut des joints









[9] Comprende le guarnizioni

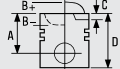
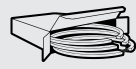





[9] Incluye los sellos



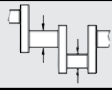
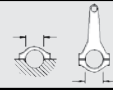

BE/PL	4	49.988/49.998	53.695/53.708	23.440	1.838	0.021/0.069	BS	60010CP	<b>71-4168/4</b> STD 0.25 0.50
MB/HL 1,3,5	3	59.960/59.973	63.657/63.676	25.530	1.837	0.020/0.067	BS	60011CP	<b>H1030/5</b> STD 0.25 0.50
MB/HL 2,4	2	59.960/59.973	63.657/63.676	18.360	1.837	0.020/0.067	BS	60012CP	
TW/A	4	65.786/66.040	82.423/82.677		2.362		AL-LF	2777AF	<b>A178/4</b> STD
SE/PB	1	21.994/22.000	25.120/25.146	23.720			BS	60014X	<b>55-4280</b> SEMI

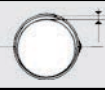

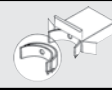
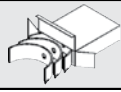







**1108**  **84.00** **Petrol**   
**AR 10520** 4 Cyl. 1962cc **97kW (132)PS** **TD10270** **424**

			
	<p><b>08-107100-00</b> STD</p> <p>1.50  CR P                  1.75  P                  4.50  P</p>		
	<p><b>08-107100-10</b> STD</p> <p>1.50  CR P                  1.75  P                  4.00  P</p>		

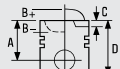
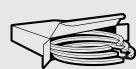
									
BE/PL	4	49.988/49.998	53.695/53.708	23.440	1.838	0.021/0.069	BS	60010CP	<b>71-4168/4</b> STD 0.25 0.50
MB/HL 1,3,5	3	59.960/59.973	63.657/63.676	25.530	1.837	0.020/0.067	BS	60011CP	<b>H1030/5</b> STD 0.25 0.50
MB/HL 2,4	2	59.960/59.973	63.657/63.676	18.360	1.837	0.020/0.067	BS	60012CP	
TW/A	4	65.786/66.040	82.423/82.677		2.362		AL-LF	2777AF	<b>A178/4</b> STD
SE/PB	1	21.994/22.000	25.120/25.146	23.720			BS	60014X	<b>55-4280</b> SEMI

		
		<b>NA5066</b>  35.00x50.00x10.00mm, ACM

**1109**  **84.00** **Petrol**   
**131 B2.000** 4 Cyl. 8.9:1 1995cc **85-103kW (115-140)PS** **TD900** **427**











			
	<p><b>08-207600-00</b> STD  <b>08-207604-00</b> 0.20mm  <b>08-207606-00</b> 0.40mm  <b>08-207608-00</b> 0.60mm</p> <p>1.50  CR P                  2.00  P                  3.95  CR [15]</p>		

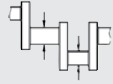





[15] Steel                      [15] Acier                      [15] Acciaio                      [15] Acero

# FIAT GROUP







...Continued



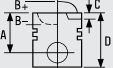
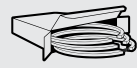





## 1109 84.00 Petrol

									
BE/PL	4	50.782/50.802	53.897/53.913	19.500	1.537	0.021/0.082	AL-LF	66240RA	<b>01-4175/4</b> STD 0.25 0.50 0.75 1.00
<b>Mot.402353 →</b>									
MB/HL 1,2,4,5	4	52.985/53.005	56.717/56.730	20.750	1.841	0.030/0.088	AL-LF	66316RA	<b>H1043/5</b> STD 0.25 0.50 0.75
MB/HL 3	1	52.985/53.005	56.717/56.730	24.250	1.841	0.030/0.088	AL-LF	66317RA	
TW/A	2	59.000/59.250	73.600/73.850		2.362		BS	62037AF	<b>A201/2</b> STD .005
SE/PB	1	21.539/21.641	23.939/23.972	25.100			BS	62039Y	<b>55-4288</b> SEMI

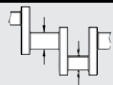



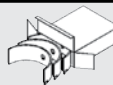

		
	<b>JJ298</b> (Cork)	<b>NB818</b>  40.00x56.00x7.00mm, ACM <b>NB732</b>  74.00x90.00x10.00mm, FPM
		
	<b>JJ298</b>	



## 1110 84.00 Petrol











<b>131 C4.000</b>	4 Cyl.	9:1	1995cc	<b>83-85kW (113-116)PS</b>	<b>TD4350</b>	<b>428</b>
						
				<b>08-207600-00</b> STD <b>08-207604-00</b> 0.20mm <b>08-207606-00</b> 0.40mm <b>08-207608-00</b> 0.60mm		
				1.50  CR P 2.00  P 3.95  CR [15]		
[15] Steel	[15] Acier	[15] Acciaio	[15] Acero			



									
BE/PL	4	50.782/50.802	53.897/53.913	19.500	1.537	0.021/0.082	AL-LF	66240RA	<b>01-4175/4</b> STD 0.25 0.50 0.75 1.00
<b>Mot.402353 →</b>									
MB/HL 1,2,4,5	4	52.985/53.005	56.717/56.730	20.750	1.841	0.030/0.088	AL-LF	66316RA	<b>H1043/5</b> STD 0.25 0.50 0.75
MB/HL 3	1	52.985/53.005	56.717/56.730	24.250	1.841	0.030/0.088	AL-LF	66317RA	
TW/A	2	59.000/59.250	73.600/73.850		2.362		BS	62037AF	<b>A201/2</b> STD .005
SE/PB	1	21.539/21.641	23.939/23.972	25.100			BS	62039Y	<b>55-4288</b> SEMI
CB/NWB	4	27.982/28.000	31.200/31.218	18.150	1.594		AL-LF	03-3981	<b>N151/6</b> STD
CB/NWB	8	27.982/28.000	31.200/31.218	18.150	1.594		AL-LF	03-3982	







...Continued

<b>1110</b>	 <b>84.00</b>	<b>Petrol</b>
		
	JH111	NA5050  70.00x90.00x10.00mm, ACM
		
	JH111	

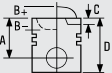
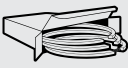
<b>1111</b>	 <b>84.00</b>	<b>Petrol</b>				
<b>132 B2.000</b>	4 Cyl.	9:1	1995cc	<b>83kW (113)PS</b>	<b>TD23356</b>	
<b>132 C2.031</b>	4 Cyl.	8.1:1	1995cc	<b>59kW (80)PS</b>	<b>TD20757</b>	
<b>132 C2.040</b>	4 Cyl.	8.1:1	1995cc	<b>63kW (86)PS</b>	<b>TD20756</b>	
<b>132 C3.040</b>	4 Cyl.	8.1:1	1995cc	<b>59kW (80)PS</b>	<b>TD20758</b>	
<b>132 DB.2A.O</b>	4 Cyl.	9:1	1995cc	<b>82kW (112)PS</b>	<b>TD23460</b>	
<b>138 AR1.000</b>	4 Cyl.		1995cc	<b>92kW (125)PS</b>	<b>TD4360</b>	<b>433</b>
<b>138 AR2.000</b>	4 Cyl.		1995cc	<b>96kW (130)PS</b>	<b>TD4361</b>	<b>433</b>

										
BE/PL	4	50.782/50.802	53.897/53.913	19.500	1.537	0.021/0.082	AL-LF	66240RA	<b>01-4175/4</b> STD 0.25 0.50 0.75 1.00	
<b>Mot.402353 →</b>										
MB/HL 1,2,4,5	4	52.985/53.005	56.717/56.730	20.750	1.841	0.030/0.088	AL-LF	66316RA	<b>H1043/5</b> STD 0.25 0.50 0.75	
MB/HL 3	1	52.985/53.005	56.717/56.730	24.250	1.841	0.030/0.088	AL-LF	66317RA		
TW/A	2	59.000/59.250	73.600/73.850		2.362		BS	62037AF	<b>A201/2</b> STD .005	
SE/PB	1	21.539/21.641	25.000/25.021	25.100			BS	66649Y	<b>55-4193</b> SEMI	
<b>01/85 →</b>										
SE/PB	1	21.539/21.641	23.939/23.972	25.100			BS	62039Y	<b>55-4288</b> SEMI	
<b>→12/84</b>										

<b>1112</b>	 <b>84.00</b>	<b>Petrol</b>				
<b>132 C2.000</b>	4 Cyl.	8.9:1	1995cc	<b>82-84kW (112-115)PS</b>	<b>TD910</b>	<b>430</b>
<b>132 C3.000</b>	4 Cyl.	9:1	1995cc	<b>88-90kW (120-122)PS</b>	<b>TD4353</b>	<b>431</b>
<b>132 D1.000</b>	4 Cyl.	9:1	1995cc	<b>83kW (113)PS</b>	<b>TD4354</b>	<b>430</b>

			
	<b>08-207600-00</b> STD <b>08-207604-00</b> 0.20mm <b>08-207606-00</b> 0.40mm <b>08-207608-00</b> 0.60mm  1.50  CR P 2.00  P 3.95  CR [15]		

[15] Steel













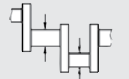
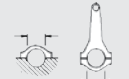





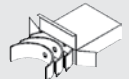

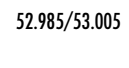
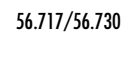

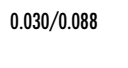

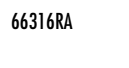



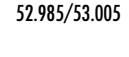
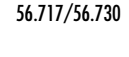

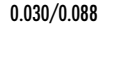

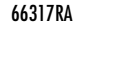

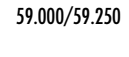
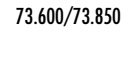



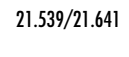
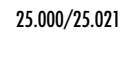

[15] Acier





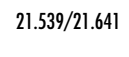
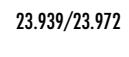



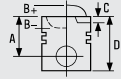
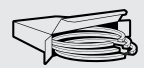

[15] Acciaio

[15] Acero



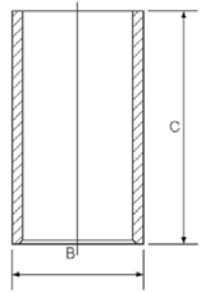





# FIAT GROUP



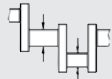
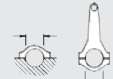





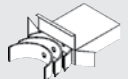

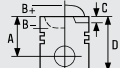
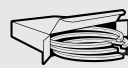
...Continued

<b>1112</b>		 <b>84.00</b>	<b>Petrol</b>								
											
BE/PL	4	50.782/50.802	53.897/53.913	19.500	1.537	0.021/0.082	AL-LF	66240RA	<b>01-4175/4</b> STD 0.25 0.50 0.75 1.00		
<b>Mot.402353</b> →											
											
MB/HL 1,2,4,5	4	52.985/53.005	56.717/56.730	20.750	1.841	0.030/0.088	AL-LF	66316RA	<b>H1043/5</b> STD 0.25 0.50 0.75		
											
MB/HL 3	1	52.985/53.005	56.717/56.730	24.250	1.841	0.030/0.088	AL-LF	66317RA			
											
TW/A	2	59.000/59.250	73.600/73.850	2.362			BS	62037AF	<b>A201/2</b> STD .005		
											
SE/PB	1	21.539/21.641	25.000/25.021	25.100			BS	66649Y	<b>55-4193</b> SEMI		
<b>01/85</b> →											
											
SE/PB	1	21.539/21.641	23.939/23.972	25.100			BS	62039Y	<b>55-4288</b> SEMI		
<b>→12/84</b>											



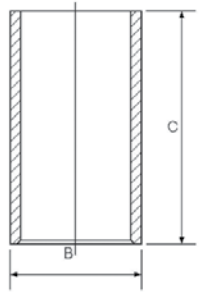





<b>1113</b>		 <b>84.00</b>	<b>Petrol</b>								
<b>132 C3.031</b>		4 Cyl.	9:1	1995cc	<b>76-77kW (103-105)PS</b>			<b>TD908</b>	<b>432</b>		
											
		<b>08-207600-00</b> STD <b>08-207604-00</b> 0.20mm <b>08-207606-00</b> 0.40mm <b>08-207608-00</b> 0.60mm		<b>14-011041-00 D</b> <b>B 88.06 C 152.00</b>							
		1.50  CR P 2.00  P 3.95  CR [15]									
		<b>08-215300-10</b> STD <b>08-215306-10</b> 0.40mm <b>08-215308-10</b> 0.60mm 02/88 →									
		1.50  CR P 2.00  P 3.95  P									
[15] Steel	[15] Acier	[15] Acciaio	[15] Acero								

...Continued

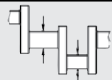
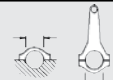
<b>1113</b>		 <b>84.00</b>		<b>Petrol</b>						
										
BE/PL	4	50.782/50.802	53.897/53.913	19.500	1.537	0.021/0.082	AL-LF	66240RA	<b>01-4175/4</b> STD 0.25 0.50 0.75 1.00	
<b>Mot.402353</b> →										
MB/HL 1,2,4,5	4	52.985/53.005	56.717/56.730	20.750	1.841	0.030/0.088	AL-LF	66316RA	<b>H1043/5</b> STD 0.25 0.50 0.75	
MB/HL 3	1	52.985/53.005	56.717/56.730	24.250	1.841	0.030/0.088	AL-LF	66317RA		
TW/A	2	59.000/59.250	73.600/73.850		2.362		BS	62037AF	<b>A201/2</b> STD .005	
SE/PB	1	21.539/21.641	25.000/25.021	25.100			BS	66649Y	<b>55-4193</b> SEMI	
<b>01/85</b> →										
SE/PB	1	21.539/21.641	23.939/23.972	25.100			BS	62039Y	<b>55-4288</b> SEMI	
→ <b>12/84</b>										



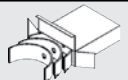

<b>1114</b>		 <b>84.00</b>		<b>Petrol</b>						
<b>154 A1.000</b>		4 Cyl.	8:1	1995cc	66kW (90)PS	Turbocharged	<b>TD1077 434</b>			
										
<p><b>08-207600-00</b> STD  <b>08-207604-00</b> 0.20mm  <b>08-207606-00</b> 0.40mm  <b>08-207608-00</b> 0.60mm</p> <p>1.50  CR P                  2.00  P                  3.95  CR [15]</p>		<p><b>14-011041-00 D</b>  <b>B 88.06 C 152.00</b></p> 								
<p><b>08-215300-10</b> STD  <b>08-215306-10</b> 0.40mm  <b>08-215308-10</b> 0.60mm                  02/88 →</p> <p>1.50  CR P                  2.00  P                  3.95  P</p>										







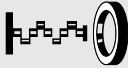

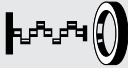
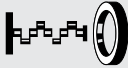

[15] Steel      [15] Acier      [15] Acciaio      [15] Acero

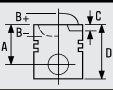
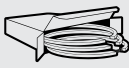

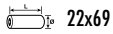
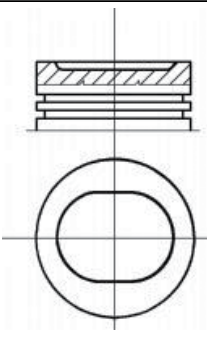



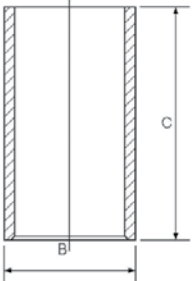

									
BE/PL	4	50.792/50.805	53.892/53.910	19.500	1.537	0.010/0.070	BS	1150CP	<b>71-4120/4</b> STD 0.25 0.50
MB/HL 1,2,4,5	4	52.990/53.010	56.717/56.735	20.750	1.843	0.020/0.080	BS	4128CP	<b>H1084/5</b> STD 0.25 0.50
MB/HL 3	1	52.990/53.010	56.717/56.735	24.250	1.843	0.020/0.080	BS	4129CP	
TW/A	2	59.000/59.250	73.600/73.850		2.362		BS	62037AF	<b>A201/2</b> STD .005
SE/PB	1	21.539/21.641	25.000/25.021	25.100			BS	66649Y	<b>55-4193</b> SEMI

# FIAT GROUP

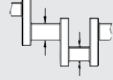
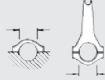
...Continued





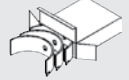

<b>1114</b>	 <b>84.00</b>	<b>Petrol</b>
		
	<b>JJ298</b> (Cork) <b>JJ413</b>  <b>JJ298</b> <b>JJ413</b>	<b>NB742</b>  30.00x43.00x8.00mm, ACM <b>NB732</b>  74.00x90.00x10.00mm, FPM



<b>1115</b>	 <b>84.00</b>	<b>Petrol</b>					
<b>154 A2.000</b>	4 Cyl.	8:1	1995cc	114kW (155)PS	<b>Turbo Intercooled</b>	<b>TD1083</b>	<b>435</b>
							
<b>87-215300-10</b> STD <b>87-215308-10</b> 0.60mm  <b>A</b> 39.50 <b>B-</b> 4.50 <b>D</b> 79.00  22x69		<b>08-215300-10</b> STD <b>08-215306-10</b> 0.40mm <b>08-215308-10</b> 0.60mm 02/88 →  1.50  CR P 2.00  P 3.95  P  <b>08-207600-00</b> STD <b>08-207604-00</b> 0.20mm <b>08-207606-00</b> 0.40mm <b>08-207608-00</b> 0.60mm  1.50  CR P 2.00  P 3.95  CR [15]	<b>14-011041-00 D</b> <b>B 88.06</b> <b>C 152.00</b>  				
[15] Steel	[15] Acier	[15] Acciaio	[15] Acero				

									
BE/PL	4	50.787/50.807	53.892/53.910	19.500	1.537	0.020/0.070	BS	1040CP	<b>71-4118/4</b> STD 0.25 0.50
MB/HL 1,2,4,5	4	52.990/53.010	56.717/56.735	20.750	1.843	0.020/0.080	BS	4128CP	<b>H1084/5</b> STD 0.25 0.50
MB/HL 3	1	52.990/53.010	56.717/56.735	24.250	1.843	0.020/0.080	BS	4129CP	
TW/A	2	59.000/59.250	73.600/73.850		2.362		BS	62037AF	<b>A201/2</b> STD .005
SE/PB	1	21.539/21.641	25.000/25.021	25.100			BS	66649Y	<b>55-4193</b> SEMI







...Continued



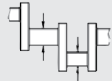
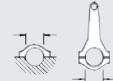

**1115**  **84.00** **Petrol**

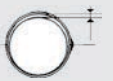
		
	<p><b>JJ298</b> (Cork) →Eng.1239615 <b>JJ413</b></p> <div style="display: flex; justify-content: space-around;">   </div> <p><b>JJ298</b>                      <b>JJ413</b></p>	<p><b>NB742</b>  30.00x43.00x8.00mm, ACM <b>NB732</b>  74.00x90.00x10.00mm, FPM</p>

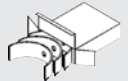
**1116**  **84.00** **Petrol** 

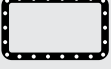
**154 C3.000**                      4 Cyl.                      9.75:1                      1995cc                      **88kW (120)PS**                      **TD18822**                      **436**

									
BE/PL	4	50.787/50.807	53.901/53.913	19.500	1.534	0.028/0.083	BS	4350CP	<b>71-4157/4</b> STD 0.25 0.50
MB/HL 1,2,4,5	4	52.985/53.005	56.717/56.730	20.750	1.841	0.030/0.088	AL-LF	66316RA	<b>H1043/5</b> STD 0.25 0.50 0.75
MB/HL 3	1	52.985/53.005	56.717/56.730	24.250	1.841	0.030/0.088	AL-LF	66317RA	
TW/A	2	59.000/59.250	73.600/73.850		2.362		BS	62037AF	<b>A201/2</b> STD .005
SE/PB	1	21.539/21.641	25.000/25.021	25.100			BS	66649Y	<b>55-4193</b> SEMI

		
	<p><b>JJ413</b></p> <div style="text-align: center;">  </div> <p><b>JJ413</b></p>	<p><b>NB742</b>  30.00x43.00x8.00mm, ACM <b>NB732</b>  74.00x90.00x10.00mm, FPM</p>

## 1117



84.00

Petrol



154 C3.046

4 Cyl.

9.75:1

1995cc

85kW (116)PS

TD984

437

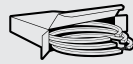
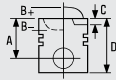

87-215300-00  
87-215306-00  
87-215308-00

STD  
0.40mm  
0.60mm

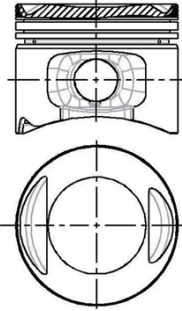

A 39.80  
B- 1.60  
D 67.80  
22x63

08-215300-10 STD  
08-215306-10 0.40mm  
08-215308-10 0.60mm

02/88 →

1.50 CR P  
2.00 P  
3.95 P



14-011041-00 D  
B 88.06 C 152.00

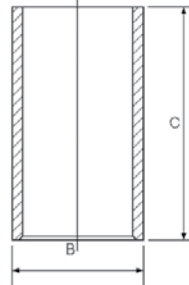

08-207600-00 STD  
08-207604-00 0.20mm  
08-207606-00 0.40mm  
08-207608-00 0.60mm

1.50 CR P  
2.00 P  
3.95 CR [15]



[15] Steel      [15] Acier      [15] Acciaio      [15] Acero

BE/PL	4	50.787/50.807	53.901/53.913	19.500	1.534	0.028/0.083	BS	4350CP	71-4157/4 STD 0.25 0.50
MB/HL 1,2,4,5	4	52.985/53.005	56.717/56.730	20.750	1.841	0.030/0.088	AL-LF	66316RA	H1043/5 STD 0.25 0.50 0.75
MB/HL 3	1	52.985/53.005	56.717/56.730	24.250	1.841	0.030/0.088	AL-LF	66317RA	
TW/A	2	59.000/59.250	73.600/73.850		2.362		BS	62037AF	A201/2 STD .005
SE/PB	1	21.539/21.641	25.000/25.021	25.100			BS	66649Y	55-4193 SEMI





JJ413

NB742 30.00x43.00x8.00mm, ACM  
NB732 74.00x90.00x10.00mm, FPM













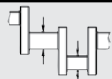

JJ413













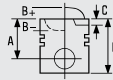

**1118**  **84.00** **Petrol** 

**154 C4.000** 4 Cyl. 8:1 1995cc **114kW (155)PS** **Turbo Intercooled** **TD18823**



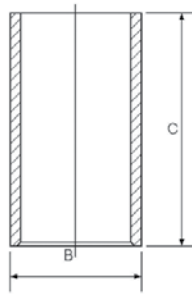





									
BE/PL	4	50.787/50.807	53.892/53.910	19.500	1.537	0.020/0.070	BS	1040CP	<b>71-4118/4</b> STD 0.25 0.50
MB/HL 1,2,4,5	4	52.990/53.010	56.717/56.735	20.750	1.843	0.020/0.080	BS	4128CP	<b>H1084/5</b> STD 0.25 0.50
MB/HL 3	1	52.990/53.010	56.717/56.735	24.250	1.843	0.020/0.080	BS	4129CP	
TW/A	2	59.000/59.250	73.600/73.850		2.362		BS	62037AF	<b>A201/2</b> STD .005
SE/PB	1	21.539/21.641	25.000/25.021	25.100			BS	66649Y	<b>55-4193</b> SEMI

**1119**  **84.00** **Petrol** 

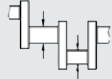
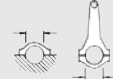
**154 C4.046** 4 Cyl. 8:1 1995cc **110kW (150)PS** **Turbo Intercooled** **TD986 438**

			
<p><b>87-215300-10</b> STD</p> <p><b>87-215308-10</b> 0.60mm</p> <p><b>A</b> 39.50</p> <p><b>B-</b> 4.50</p> <p><b>D</b> 79.00</p> <p> 22x69</p>	<p><b>08-215300-10</b> STD</p> <p><b>08-215306-10</b> 0.40mm</p> <p><b>08-215308-10</b> 0.60mm</p> <p>02/88 →</p> <p>1.50  CR P</p> <p>2.00  P</p> <p>3.95  P</p>	<p><b>14-011041-00 D</b></p> <p><b>B</b> 88.06 <b>C</b> 152.00</p> <p></p>	
	<p><b>08-207600-00</b> STD</p> <p><b>08-207604-00</b> 0.20mm</p> <p><b>08-207606-00</b> 0.40mm</p> <p><b>08-207608-00</b> 0.60mm</p> <p>1.50  CR P</p> <p>2.00  P</p> <p>3.95  CR [15]</p>		

[15] Steel      [15] Acier      [15] Acciaio      [15] Acero

									
BE/PL	4	50.787/50.807	53.892/53.910	19.500	1.537	0.020/0.070	BS	1040CP	<b>71-4118/4</b> STD 0.25 0.50
MB/HL 1,2,4,5	4	52.990/53.010	56.717/56.735	20.750	1.843	0.020/0.080	BS	4128CP	<b>H1084/5</b> STD 0.25 0.50
MB/HL 3	1	52.990/53.010	56.717/56.735	24.250	1.843	0.020/0.080	BS	4129CP	
TW/A	2	59.000/59.250	73.600/73.850		2.362		BS	62037AF	<b>A201/2</b> STD .005
SE/PB	1	21.539/21.641	25.000/25.021	25.100			BS	66649Y	<b>55-4193</b> SEMI

# FIAT GROUP

...Continued

## 1119 84.00 Petrol

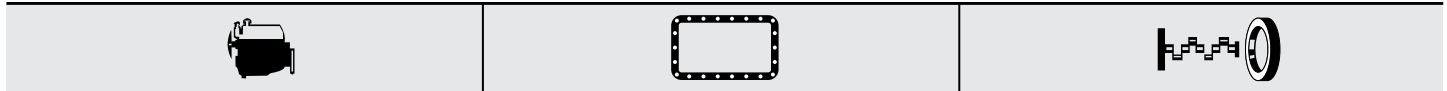

JJ413











NB742  30.00x43.00x8.00mm, ACM

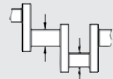
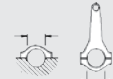

JJ413



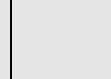



## 1120 84.00 Petrol

154 C5.000      4 Cyl.      9.5:1      1995cc      66kW (90)PS      TD23358

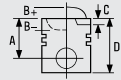
										
BE/PL	4	50.792/50.805	53.892/53.910	19.500	1.537	0.010/0.070	BS	1150CP	71-4120/4 STD 0.25 0.50	
MB/HL 1,2,4,5	4	52.990/53.010	56.717/56.735	20.750	1.843	0.020/0.080	BS	4128CP	H1084/5 STD 0.25 0.50	
MB/HL 3	1	52.990/53.010	56.717/56.735	24.250	1.843	0.020/0.080	BS	4129CP		
TW/A	2	59.000/59.250	73.600/73.850		2.362		BS	62037AF	A201/2 STD .005	
SE/PB	1	21.539/21.641	25.000/25.021	25.100			BS	66649Y	55-4193 SEMI	





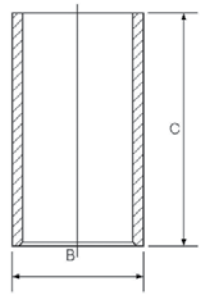



## 1121 84.00 Petrol

154 E1.000	4 Cyl.	1995cc	101kW (137)PS	TD989	439
834 F1.000	4 Cyl.	1995cc	110-112kW (150-152)PS	TD1831	467
836 A3.000	4 Cyl.	10.5:1	102kW (139)PS	TD1071	476
836 A3.000	4 Cyl.	10:1	102-108kW (139-147)PS	TD4614	475

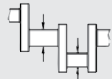
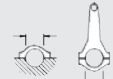
			
	<p>08-142400-00 STD</p> <p>08-142406-00 0.40mm</p> <p>1.50  CK</p> <p>1.50  P</p> <p>3.00  P</p>	<p>14-011041-00 D</p> <p>B 88.06 C 152.00</p> 	

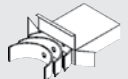

...Continued

**1121**  **84.00** **Petrol**

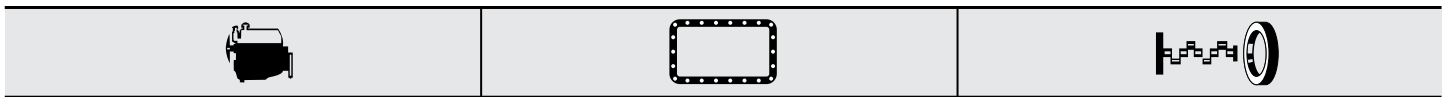
									
BE/PL	4	50.787/50.807	53.901/53.913	19.500	1.534	0.028/0.083	BS	4350CP	<b>71-4157/4</b> STD 0.25 0.50
MB/HL 1,2,4,5	4	52.990/53.010	56.717/56.735	20.750	1.843	0.020/0.080	BS	4128CP	<b>H1084/5</b> STD 0.25 0.50
MB/HL 3	1	52.990/53.010	56.717/56.735	24.250	1.843	0.020/0.080	BS	4129CP	
TW/A	2	59.000/59.250	73.600/73.850		2.362		BS	62037AF	<b>A201/2</b> STD .005
SE/PB	1	21.539/21.641	25.000/25.021	25.100			BS	66649Y	<b>55-4193</b> SEMI



JJ413













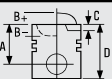



**NB742**  30.00x43.00x8.00mm, ACM  
**NB732**  74.00x90.00x10.00mm, FPM

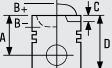
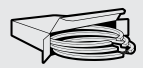

JJ413

**1122**  **84.00** **Petrol**

159 A5.046      4 Cyl.      9.5:1      1995cc      80-85kW (109-116)PS      TD1011      440









											
											
			<p><b>08-207600-00</b> STD <b>08-207604-00</b> 0.20mm <b>08-207606-00</b> 0.40mm <b>08-207608-00</b> 0.60mm</p>								
			<p>1.50  CR P 2.00  P 3.95  CR [15]</p>								

[15] Steel

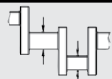
[15] Acier

[15] Acciaio

[15] Acero

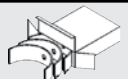
									
BE/PL	4	50.787/50.807	53.892/53.910	19.500	1.537	0.020/0.070	BS	1040CP	<b>71-4118/4</b> STD 0.25 0.50
MB/HL 1,2,4,5	4	52.985/53.005	56.717/56.730	20.750	1.841	0.030/0.088	AL-LF	66316RA	<b>H1043/5</b> STD 0.25 0.50 0.75
MB/HL 3	1	52.985/53.005	56.717/56.730	24.250	1.841	0.030/0.088	AL-LF	66317RA	
TW/A	2	59.000/59.250	73.600/73.850		2.362		BS	62037AF	<b>A201/2</b> STD .005
SE/PB	1	21.539/21.641	25.000/25.021	25.100			BS	66649Y	<b>55-4193</b> SEMI

## 1123



84.00

Petrol



159 A6.046

4 Cyl.

9.5:1

1995cc

83-85kW (113-116)PS

TD1012

441

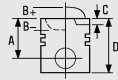

08-207600-00 STD  
 08-207604-00 0.20mm  
 08-207606-00 0.40mm  
 08-207608-00 0.60mm

1.50 CR P  
 2.00 P  
 3.95 CR [15]

[15] Steel

[15] Acier

[15] Acciaio

[15] Acero

BE/PL	4	50.787/50.807	53.892/53.910	19.500	1.537	0.020/0.070	BS	1040CP	71-4118/4 STD 0.25 0.50
MB/HL 1,2,4,5	4	52.985/53.005	56.717/56.730	20.750	1.841	0.030/0.088	AL-LF	66316RA	H1043/5 STD 0.25 0.50 0.75
MB/HL 3	1	52.985/53.005	56.717/56.730	24.250	1.841	0.030/0.088	AL-LF	66317RA	
TW/A	2	59.000/59.250	73.600/73.850		2.362		BS	62037AF	A201/2 STD .005
SE/PB	1	21.539/21.641	25.000/25.021	25.100			BS	66649Y	55-4193 SEMI



JJ298  
(Cork)



JJ298

NB742 30.00x43.00x8.00mm, ACM  
 NB825 30.00x43.00x8.00mm, FPM

## 1124



84.00

Petrol



160 A8.046

4 Cyl.

1995cc

107kW (146)PS

TD1024

442

834 C1.246

4 Cyl.

8:1

1995cc

130kW (177)PS

Turbo Intercooled







TD1836

466

BE/PL	4	50.787/50.807	53.901/53.913	19.500	1.534	0.028/0.083	BS	4350CP	71-4157/4 STD 0.25 0.50
MB/HL 1,2,4,5	4	52.990/53.010	56.717/56.735	20.750	1.843	0.020/0.080	BS	4128CP	H1084/5 STD 0.25 0.50
MB/HL 3	1	52.990/53.010	56.717/56.735	24.250	1.843	0.020/0.080	BS	4129CP	
TW/A	2	59.000/59.250	73.600/73.850		2.362		BS	62037AF	A201/2 STD .005
SE/PB	1	21.539/21.641	25.000/25.021	25.100			BS	66649Y	55-4193 SEMI



...Continued







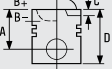
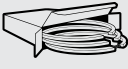

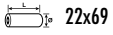
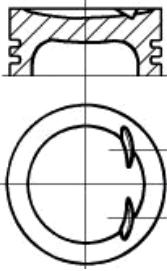
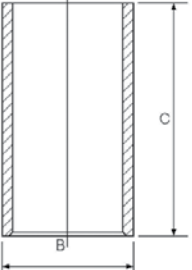
**1124**  **84.00** **Petrol**



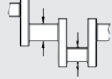
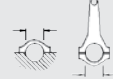

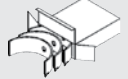

		
	JJ413	NB742  30.00x43.00x8.00mm, ACM NB732  74.00x90.00x10.00mm, FPM
		
	JJ413	

**1125**  **84.00** **Petrol**

175 A1.000	4 Cyl.	8:1	1995cc	140kW (190)PS	Turbo Intercooled	TD4395	443
831 E5.000	4 Cyl.	8:1	1995cc	155kW (211)PS	Turbocharged	TD1827	452
831 E5.046	4 Cyl.	8:1	1995cc	155kW (211)PS	Turbocharged	TD1826	452
836 A2.000	4 Cyl.	10:1	1995cc	137kW (186)PS	Turbo Intercooled	TD5435	474

			
87-142400-00 87-142406-00	STD 0.40mm	08-142400-00 STD 08-142406-00 0.40mm	14-011041-00 D B 88.06 C 152.00
A 39.00 B- 6.00 BØ 72.00 C 2.00 D 69.00  22x69		1.50 CK 1.50 P 3.00 P	
AK			

									
BE/PL	4	50.787/50.807	53.901/53.913	19.500	1.534	0.028/0.083	BS	4350CP	71-4157/4 STD 0.25 0.50
MB/HL 1,2,4,5	4	52.990/53.010	56.717/56.735	20.750	1.843	0.020/0.080	BS	4128CP	H1084/5 STD 0.25 0.50
MB/HL 3	1	52.990/53.010	56.717/56.735	24.250	1.843	0.020/0.080	BS	4129CP	
TW/A	2	59.000/59.250	73.600/73.850		2.362		BS	62037AF	A201/2 STD .005
SE/PB	1	21.539/21.641	25.000/25.021	25.100			BS	66649Y	55-4193 SEMI

		
	JJ413	NB825  30.00x43.00x8.00mm, FPM NB732  74.00x90.00x10.00mm, FPM
		
	JJ413	

# FIAT GROUP

## 1126



84.00

Petrol



175 A4.000	4 Cyl.	8:1	1995cc	142kW (193)PS	Turbocharged	TD11827	444
834 C1.000	4 Cyl.	8:1	1995cc	133kW (181)PS	Turbo Intercooled	TD1835	465
834 F2.000	4 Cyl.		1995cc	148kW (202)PS	Turbo Intercooled	TD1840	468

<b>87-142400-00</b> STD <b>87-142406-00</b> 0.40mm  <b>A</b> 39.00 <b>B-</b> 6.00 <b>BØ</b> 72.00 <b>C</b> 2.00 <b>D</b> 69.00 22x69  <b>AK</b>	<b>08-142400-00</b> STD <b>08-142406-00</b> 0.40mm  1.50  CK 1.50  P 3.00  P	<b>14-011041-00 D</b> <b>B</b> 88.06 <b>C</b> 152.00  	

BE/PL	4	50.787/50.807	53.901/53.913	19.500	1.534	0.028/0.083	BS	4350CP	<b>71-4157/4</b> STD 0.25 0.50	
MB/HL 1,2,4,5	4	52.990/53.010	56.717/56.735	20.750	1.843	0.020/0.080	BS	4128CP	<b>H1084/5</b> STD 0.25 0.50	
MB/HL 3	1	52.990/53.010	56.717/56.735	24.250	1.843	0.020/0.080	BS	4129CP		
TW/A	2	59.000/59.250	73.600/73.850		2.362		BS	62037AF	<b>A201/2</b> STD .005	
SE/PB	1	21.539/21.641	25.000/25.021	25.100			BS	66649Y	<b>55-4193</b> SEMI	

## 1127



84.00

Petrol











828 B4.000	4 Cyl.	8.9:1	1995cc	90kW (122)PS		TD4602	445
------------	--------	-------	--------	--------------	--	--------	-----

	<b>08-207600-00</b> STD <b>08-207604-00</b> 0.20mm <b>08-207606-00</b> 0.40mm <b>08-207608-00</b> 0.60mm  1.50  CR P 2.00  P 3.95  CR [15]	<b>14-011041-00 D</b> <b>B</b> 88.06 <b>C</b> 152.00  	
	<b>08-215300-10</b> STD <b>08-215306-10</b> 0.40mm <b>08-215308-10</b> 0.60mm 02/88 →  1.50  CR P 2.00  P 3.95  P		

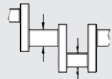
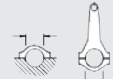
[15] Steel      [15] Acier      [15] Acciaio      [15] Acero

...Continued

**1127**  **84.00** **Petrol**

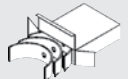
									
BE/PL	4	50.782/50.802	53.897/53.913	19.500	1.537	0.021/0.082	AL-LF	66240RA	<b>01-4175/4</b> STD 0.25 0.50 0.75 1.00
MB/HL 1,2,4,5	4	52.985/53.005	56.717/56.730	20.750	1.841	0.030/0.088	AL-LF	66316RA	<b>H1043/5</b> STD 0.25 0.50 0.75
MB/HL 3	1	52.985/53.005	56.717/56.730	24.250	1.841	0.030/0.088	AL-LF	66317RA	
TW/A	2	59.000/59.250	73.600/73.850		2.362		BS	62037AF	<b>A201/2</b> STD .005
SE/PB	1	21.539/21.641	25.000/25.021	25.100			BS	66649Y	<b>55-4193</b> SEMI
SE/PB	1	21.539/21.641	23.939/23.972	25.100			BS	62039Y	<b>55-4288</b> SEMI

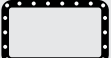
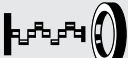
		
---	---	---

JH111









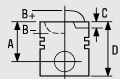

NB732  74.00x90.00x10.00mm, FPM

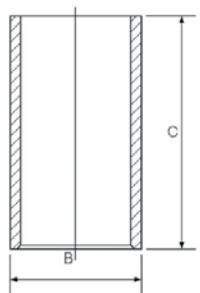

JH111

**1128**  **84.00** **Petrol** 

831 B4.000      4 Cyl.      9.7:1      1995cc      85kW (115)PS      TD1812      447

			
	<p><b>08-207600-00</b> STD</p> <p><b>08-207604-00</b> 0.20mm</p> <p><b>08-207606-00</b> 0.40mm</p> <p><b>08-207608-00</b> 0.60mm</p> <p>1.50  CR P</p> <p>2.00  P</p> <p>3.95  CR [15]</p>	<p><b>14-011041-00 D</b></p> <p>B 88.06 C 152.00</p> 	
	<p><b>08-215300-10</b> STD</p> <p><b>08-215306-10</b> 0.40mm</p> <p><b>08-215308-10</b> 0.60mm</p> <p>02/88 →</p> <p>1.50  CR P</p> <p>2.00  P</p> <p>3.95  P</p>		









[15] Steel

[15] Acier

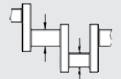
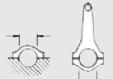
[15] Acciaio



[15] Acero

**1128**  **84.00** **Petrol**

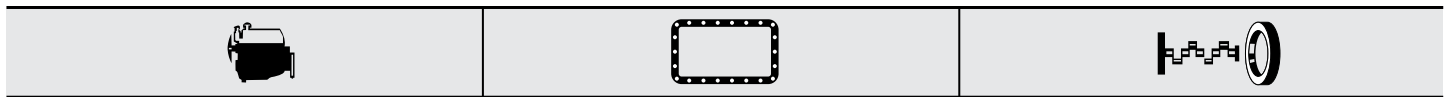
									
BE/PL	4	50.792/50.805	53.892/53.910	19.500	1.537	0.010/0.070	BS	1150CP	<b>71-4120/4</b> STD 0.25 0.50
MB/HL 1,2,4,5	4	52.985/53.005	56.717/56.730	20.750	1.841	0.030/0.088	AL-LF	66316RA	<b>H1043/5</b> STD 0.25 0.50 0.75
MB/HL 3	1	52.985/53.005	56.717/56.730	24.250	1.841	0.030/0.088	AL-LF	66317RA	
TW/A	2	59.000/59.250	73.600/73.850		2.362		BS	62037AF	<b>A201/2</b> STD .005
SE/PB	1	21.539/21.641	25.000/25.021	25.100			BS	66649Y	<b>55-4193</b> SEMI



JH111







**NB742**  30.00x43.00x8.00mm, ACM  
**NB732**  74.00x90.00x10.00mm, FPM

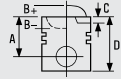

JH111

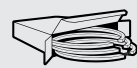
**1129**  **84.00** **Petrol** 

<b>831 B5.000</b>	4 Cyl.	8:1	1995cc	<b>122kW (166)PS</b>	<b>Turbo Intercooled</b>	<b>TD1823</b>	<b>448</b>
<b>835 A7.000</b>	4 Cyl.	8:1	1995cc	<b>121kW (165)PS</b>	<b>Turbo Intercooled</b>	<b>TD1849</b>	<b>471</b>
<b>835 A7.046</b>	4 Cyl.	8:1	1995cc	<b>124kW (169)PS</b>	<b>Turbocharged</b>	<b>TD1850</b>	<b>448</b>

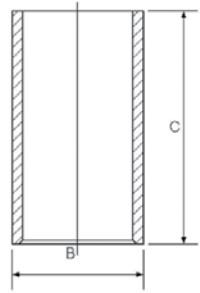
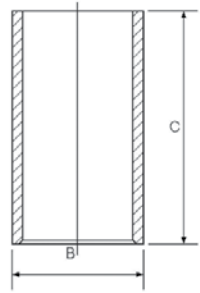







 <p><b>87-215300-10</b> STD <b>87-215308-10</b> 0.60mm</p> <p>A 39.50 B- 4.50 D 79.00  22x69</p>	 <p><b>08-215300-10</b> STD <b>08-215306-10</b> 0.40mm <b>08-215308-10</b> 0.60mm 02/88 →</p> <p>1.50  CR P 2.00  P 3.95  P</p>	 <p><b>14-011041-00 D</b> B 88.06 C 152.00</p>	

[15] Steel                      [15] Acier                      [15] Acciaio                      [15] Acero

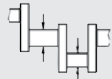
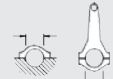

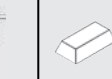
...Continued

**1129**  **84.00** **Petrol**

									
BE/PL	4	50.787/50.807	53.892/53.910	19.500	1.537	0.020/0.070	BS	1040CP	<b>71-4118/4</b> STD 0.25 0.50
MB/HL 1,2,4,5	4	52.990/53.010	56.717/56.735	20.750	1.843	0.020/0.080	BS	4128CP	<b>H1084/5</b> STD 0.25 0.50
MB/HL 3	1	52.990/53.010	56.717/56.735	24.250	1.843	0.020/0.080	BS	4129CP	
TW/A	2	59.000/59.250	73.600/73.850		2.362		BS	62037AF	<b>A201/2</b> STD .005
SE/PB	1	21.539/21.641	25.000/25.021	25.100			BS	66649Y	<b>55-4193</b> SEMI

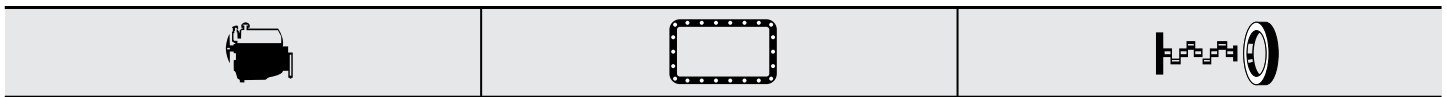

JH111

NB742  30.00x43.00x8.00mm, ACM  
NB732  74.00x90.00x10.00mm, FPM





JH111

**1130**  **84.00** **Petrol** 

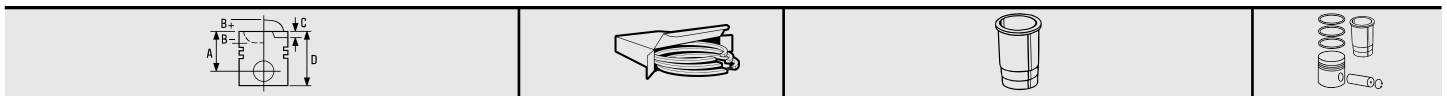

831 C5.000      4 Cyl.      8:1      1995cc      133kW (181)PS      Turbocharged      TD1821      449



**08-207600-00** STD  
**08-207604-00** 0.20mm  
**08-207606-00** 0.40mm  
**08-207608-00** 0.60mm

1.50  CR P  
2.00  P  
3.95  CR [15]

**08-215300-10** STD  
**08-215306-10** 0.40mm  
**08-215308-10** 0.60mm  
02/88 →

1.50  CR P  
2.00  P  
3.95  P

**14-011041-00 D**  
B 88.06    C 152.00

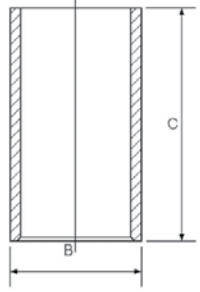







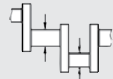
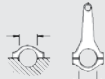

[15] Steel      [15] Acier      [15] Acciaio      [15] Acero

# FIAT GROUP

...Continued

## 1130 84.00 Petrol

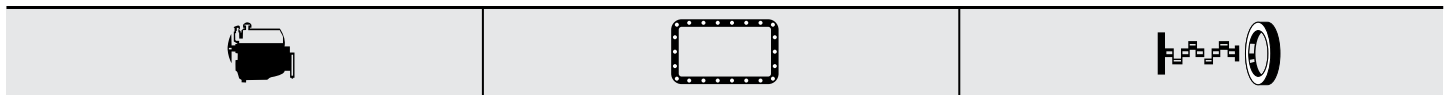

									
BE/PL	4	50.787/50.807	53.892/53.910	19.500	1.537	0.020/0.070	BS	1040CP	<b>71-4118/4</b> STD 0.25 0.50
MB/HL 1,2,4,5	4	52.990/53.010	56.717/56.735	20.750	1.843	0.020/0.080	BS	4128CP	<b>H1084/5</b> STD 0.25 0.50
MB/HL 3	1	52.990/53.010	56.717/56.735	24.250	1.843	0.020/0.080	BS	4129CP	
TW/A	2	59.000/59.250	73.600/73.850		2.362		BS	62037AF	<b>A201/2</b> STD .005
SE/PB	1	21.539/21.641	25.000/25.021	25.100			BS	66649Y	<b>55-4193</b> SEMI



**JJ298**  
(Cork)



JJ298

**NB742**  30.00x43.00x8.00mm, ACM  
**NB732**  74.00x90.00x10.00mm, FPM





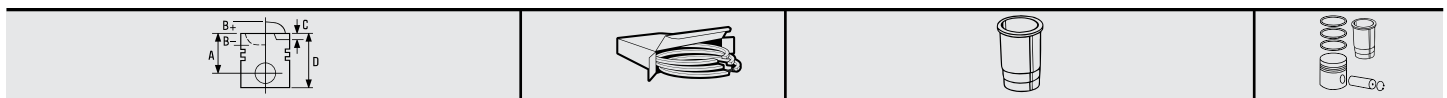

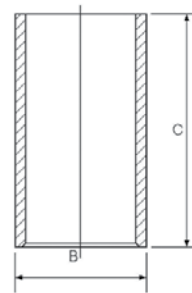

## 1131 84.00 Petrol

831 C5.046 4 Cyl. 8:1 1995cc 130kW (177)PS Turbocharged TD1822 450

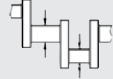
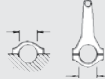

















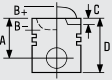

**14-011041-00 D**  
B 88.06 C 152.00





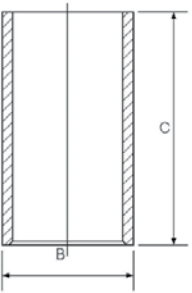







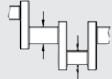



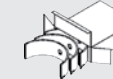

									
BE/PL	4	50.787/50.807	53.892/53.910	19.500	1.537	0.020/0.070	BS	1040CP	<b>71-4118/4</b> STD 0.25 0.50
MB/HL 1,2,4,5	4	52.990/53.010	56.717/56.735	20.750	1.843	0.020/0.080	BS	4128CP	<b>H1084/5</b> STD 0.25 0.50
MB/HL 3	1	52.990/53.010	56.717/56.735	24.250	1.843	0.020/0.080	BS	4129CP	
TW/A	2	59.000/59.250	73.600/73.850		2.362		BS	62037AF	<b>A201/2</b> STD .005
SE/PB	1	21.539/21.641	25.000/25.021	25.100			BS	66649Y	<b>55-4193</b> SEMI

...Continued

<b>1131</b>	 <b>84.00</b>	<b>Petrol</b>
		
 <b>JH111</b>		<b>NB825</b>  30.00x43.00x8.00mm, FPM <b>NB732</b>  74.00x90.00x10.00mm, FPM

<b>1132</b>	 <b>84.00</b>	<b>Petrol</b>					
<b>831 D5.000</b>	4 Cyl.	8:1	1995cc	144kW (196)PS	<b>Turbocharged</b>	<b>TD1825</b>	<b>451</b>
							
		<b>08-207600-00</b> STD <b>08-207604-00</b> 0.20mm <b>08-207606-00</b> 0.40mm <b>08-207608-00</b> 0.60mm  1.50  CR P 2.00  P 3.95  CR [15]	<b>14-011041-00 D</b> <b>B 88.06 C 152.00</b>  				
		<b>08-215300-10</b> STD <b>08-215306-10</b> 0.40mm <b>08-215308-10</b> 0.60mm 02/88 →  1.50  CR P 2.00  P 3.95  P					
[15] Steel	[15] Acier	[15] Acciaio	[15] Acero				

										
BE/PL	4	50.787/50.807	53.901/53.913	19.500	1.534	0.028/0.083	BS	4350CP	<b>71-4157/4</b> STD 0.25 0.50	
MB/HL 1,2,4,5	4	52.990/53.010	56.717/56.735	20.750	1.843	0.020/0.080	BS	4128CP	<b>H1084/5</b> STD 0.25 0.50	
MB/HL 3	1	52.990/53.010	56.717/56.735	24.250	1.843	0.020/0.080	BS	4129CP		
TW/A	2	59.000/59.250	73.600/73.850		2.362		BS	62037AF	<b>A201/2</b> STD .005	
SE/PB	1	21.539/21.641	25.000/25.021	25.100			BS	66649Y	<b>55-4193</b> SEMI	

		
 <b>JJ298</b> (Cork)		<b>NB825</b>  30.00x43.00x8.00mm, FPM <b>NB732</b>  74.00x90.00x10.00mm, FPM

## 1133

 84.00



Petrol

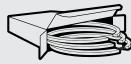
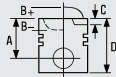

834 B.000      4 Cyl.      9.7:1      1995cc      88kW (120)PS      TD1084      453



**08-207600-00** STD  
**08-207604-00** 0.20mm  
**08-207606-00** 0.40mm  
**08-207608-00** 0.60mm

1.50  CR P  
 2.00  P  
 3.95  CR [15]







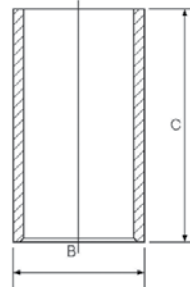

**08-215300-10** STD  
**08-215306-10** 0.40mm  
**08-215308-10** 0.60mm  
 02/88 →

1.50  CR P  
 2.00  P  
 3.95  P

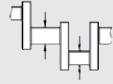
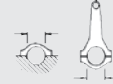
**14-011041-00 D**  
 B 88.06 C 152.00

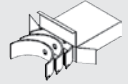

[15] Steel      [15] Acier      [15] Acciaio      [15] Acero

									
BE/PL	4	50.792/50.805	53.892/53.910	19.500	1.537	0.010/0.070	BS	1150CP	<b>71-4120/4</b> STD 0.25 0.50
MB/HL 1,2,4,5	4	52.985/53.005	56.717/56.730	20.750	1.841	0.030/0.088	AL-LF	66316RA	<b>H1043/5</b> STD 0.25 0.50 0.75
MB/HL 3	1	52.985/53.005	56.717/56.730	24.250	1.841	0.030/0.088	AL-LF	66317RA	
TW/A	2	59.000/59.250	73.600/73.850		2.362		BS	62037AF	<b>A201/2</b> STD .005
SE/PB	1	21.539/21.641	25.000/25.021	25.100			BS	66649Y	<b>55-4193</b> SEMI

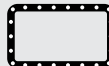



**JJ298**  
(Cork)  
**JJ413**













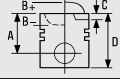
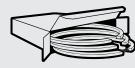

JJ298





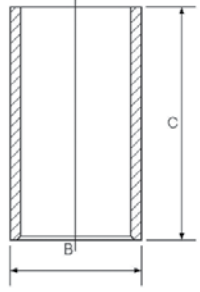





JJ413



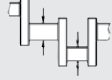
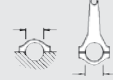



**NB742**  30.00x43.00x8.00mm, ACM  
**NB732**  74.00x90.00x10.00mm, FPM

<b>1134</b>	 <b>84.00</b>	<b>Petrol</b>	
<b>834 B.000</b>	4 Cyl.	9.8:1	1995cc
			<b>88kW (120)PS</b>
			<b>TD1833 454</b>

			
	<p><b>08-207600-00</b> STD</p> <p><b>08-207604-00</b> 0.20mm</p> <p><b>08-207606-00</b> 0.40mm</p> <p><b>08-207608-00</b> 0.60mm</p> <p>1.50  CR P</p> <p>2.00  P</p> <p>3.95  CR [15]</p>	<p><b>14-011041-00 D</b></p> <p><b>B 88.06 C 152.00</b></p> 	
	<p><b>08-215300-10</b> STD</p> <p><b>08-215306-10</b> 0.40mm</p> <p><b>08-215308-10</b> 0.60mm</p> <p>02/88 →</p> <p>1.50  CR P</p> <p>2.00  P</p> <p>3.95  P</p>		

[15] Steel                      [15] Acier                      [15] Acciaio                      [15] Acero

									
BE/PL	4	50.792/50.805	53.892/53.910	19.500	1.537	0.010/0.070	BS	1150CP	<b>71-4120/4</b> STD 0.25 0.50
MB/HL 1,2,4,5	4	52.985/53.005	56.717/56.730	20.750	1.841	0.030/0.088	AL-LF	66316RA	<b>H1043/5</b> STD 0.25 0.50 0.75
MB/HL 3	1	52.985/53.005	56.717/56.730	24.250	1.841	0.030/0.088	AL-LF	66317RA	
TW/A	2	59.000/59.250	73.600/73.850		2.362		BS	62037AF	<b>A201/2</b> STD .005
SE/PB	1	21.539/21.641	25.000/25.021	25.100			BS	66649Y	<b>55-4193</b> SEMI

		
<b>JJ298</b> (Cork)		<b>NB825</b>  30.00x43.00x8.00mm, FPM
		<b>NB732</b>  74.00x90.00x10.00mm, FPM
<b>JJ298</b>		

## 1135



84.00

Petrol













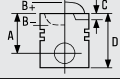
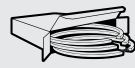

834 B.048	4 Cyl.	9.8:1	1995cc	83-85kW (112-113)PS	TD1829	456
834 B.146	4 Cyl.	9.8:1	1995cc	85kW (116)PS	TD1818	458
834 B1.000	4 Cyl.	9.5:1	1995cc	86kW (117)PS	TD1830	459

				<b>08-207600-00</b> STD <b>08-207604-00</b> 0.20mm <b>08-207606-00</b> 0.40mm <b>08-207608-00</b> 0.60mm  1.50  CR P 2.00  P 3.95  CR [15]	<b>14-011041-00 D</b> B 88.06 C 152.00  
				<b>08-215300-10</b> STD <b>08-215306-10</b> 0.40mm <b>08-215308-10</b> 0.60mm 02/88 →  1.50  CR P 2.00  P 3.95  P	



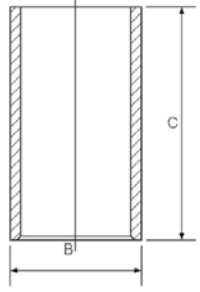





[15] Steel      [15] Acier      [15] Acciaio      [15] Acero



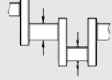
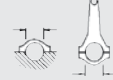

BE/PL	4	50.792/50.805	53.892/53.910	19.500	1.537	0.010/0.070	BS	1150CP	<b>71-4120/4</b> STD 0.25 0.50
MB/HL 1,2,4,5	4	52.985/53.005	56.717/56.730	20.750	1.841	0.030/0.088	AL-LF	66316RA	<b>H1043/5</b> STD 0.25 0.50 0.75
MB/HL 3	1	52.985/53.005	56.717/56.730	24.250	1.841	0.030/0.088	AL-LF	66317RA	
TW/A	2	59.000/59.250	73.600/73.850		2.362		BS	62037AF	<b>A201/2</b> STD .005
SE/PB	1	21.539/21.641	25.000/25.021	25.100			BS	66649Y	<b>55-4193</b> SEMI

<b>1136</b>	 <b>84.00</b>	<b>Petrol</b>	
<b>834 B.048</b>	4 Cyl.	9.7:1	1995cc
			<b>83kW (113)PS</b>
			<b>TD1085 455</b>

			
	<p><b>08-207600-00</b> STD</p> <p><b>08-207604-00</b> 0.20mm</p> <p><b>08-207606-00</b> 0.40mm</p> <p><b>08-207608-00</b> 0.60mm</p> <p>1.50  CR P</p> <p>2.00  P</p> <p>3.95  CR [15]</p>	<p><b>14-011041-00 D</b></p> <p><b>B 88.06 C 152.00</b></p> 	
	<p><b>08-215300-10</b> STD</p> <p><b>08-215306-10</b> 0.40mm</p> <p><b>08-215308-10</b> 0.60mm</p> <p>02/88 →</p> <p>1.50  CR P</p> <p>2.00  P</p> <p>3.95  P</p>		

[15] Steel                      [15] Acier                      [15] Acciaio                      [15] Acero

									
BE/PL	4	50.792/50.805	53.892/53.910	19.500	1.537	0.010/0.070	BS	1150CP	<b>71-4120/4</b> STD 0.25 0.50
MB/HL 1,2,4,5	4	52.985/53.005	56.717/56.730	20.750	1.841	0.030/0.088	AL-LF	66316RA	<b>H1043/5</b> STD 0.25 0.50 0.75
MB/HL 3	1	52.985/53.005	56.717/56.730	24.250	1.841	0.030/0.088	AL-LF	66317RA	
TW/A	2	59.000/59.250	73.600/73.850		2.362		BS	62037AF	<b>A201/2</b> STD .005
SE/PB	1	21.539/21.641	25.000/25.021	25.100			BS	66649Y	<b>55-4193</b> SEMI

		
		<p><b>NB742</b>  30.00x43.00x8.00mm, ACM</p> <p><b>NB732</b>  74.00x90.00x10.00mm, FPM</p>

## 1137

 84.00

Petrol



834 B.146      4 Cyl.      9.7:1      1995cc      85kW (116)PS      TD11707      457

	<p><b>08-207600-00</b> STD  <b>08-207604-00</b> 0.20mm  <b>08-207606-00</b> 0.40mm  <b>08-207608-00</b> 0.60mm</p> <p>1.50  CR P                  2.00  P                  3.95  CR [15]</p>	<p><b>14-011041-00 D</b>                  B 88.06 C 152.00</p>	
	<p><b>08-215300-10</b> STD  <b>08-215306-10</b> 0.40mm  <b>08-215308-10</b> 0.60mm                  02/88 →</p> <p>1.50  CR P                  2.00  P                  3.95  P</p>		

[15] Steel      [15] Acier      [15] Acciaio      [15] Acero

BE/PL	4	50.792/50.805	53.892/53.910	19.500	1.537	0.010/0.070	BS	1150CP	<b>71-4120/4</b> STD 0.25 0.50
MB/HL 1,2,4,5	4	52.985/53.005	56.717/56.730	20.750	1.841	0.030/0.088	AL-LF	66316RA	<b>H1043/5</b> STD 0.25 0.50 0.75
MB/HL 3	1	52.985/53.005	56.717/56.730	24.250	1.841	0.030/0.088	AL-LF	66317RA	
TW/A	2	59.000/59.250	73.600/73.850		2.362		BS	62037AF	<b>A201/2</b> STD .005
SE/PB	1	21.539/21.641	25.000/25.021	25.100			BS	66649Y	<b>55-4193</b> SEMI

	<p>JJ413</p>	<p><b>NB742</b>  30.00x43.00x8.00mm, ACM  <b>NB732</b>  74.00x90.00x10.00mm, FPM</p>
	<p>JJ413</p>	



## 1138

### 84.00

### Petrol



834 B2.000

4 Cyl.

1995cc

108kW (147)PS

TD14549

460

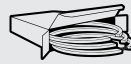
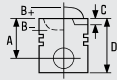

**08-207600-00** STD  
**08-207604-00** 0.20mm  
**08-207606-00** 0.40mm  
**08-207608-00** 0.60mm

1.50 CR P  
 2.00 P  
 3.95 CR [15]

**08-215300-10** STD  
**08-215306-10** 0.40mm  
**08-215308-10** 0.60mm  
 02/88 →

1.50 CR P  
 2.00 P  
 3.95 P

[15] Steel

[15] Acier

[15] Acciaio

[15] Acero

BE/PL	4	50.787/50.807	53.901/53.913	19.500	1.534	0.028/0.083	BS	4350CP	<b>71-4157/4</b> STD 0.25 0.50
MB/HL 1,2,4,5	4	52.985/53.005	56.717/56.730	20.750	1.841	0.030/0.088	AL-LF	66316RA	<b>H1043/5</b> STD 0.25 0.50 0.75
MB/HL 3	1	52.985/53.005	56.717/56.730	24.250	1.841	0.030/0.088	AL-LF	66317RA	
TW/A	2	59.000/59.250	73.600/73.850		2.362		BS	62037AF	<b>A201/2</b> STD .005
SE/PB	1	21.539/21.641	25.000/25.021	25.100			BS	66649Y	<b>55-4193</b> SEMI



JJ413

**NB825** 30.00x43.00x8.00mm, FPM

**NB732** 74.00x90.00x10.00mm, FPM



JJ413

## 1139

 84.00

Petrol



834 B2.246

4 Cyl.

8:1

1995cc

104kW (141)PS



Turbocharged

TD1832

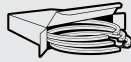
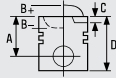
461



**08-207600-00** STD  
**08-207604-00** 0.20mm  
**08-207606-00** 0.40mm  
**08-207608-00** 0.60mm

1.50  CR P  
 2.00  P  
 3.95  CR [15]







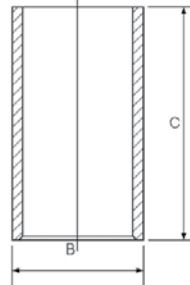

**08-215300-10** STD  
**08-215306-10** 0.40mm  
**08-215308-10** 0.60mm  
 02/88 →

1.50  CR P  
 2.00  P  
 3.95  P

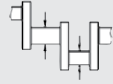
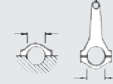
**14-011041-00 D**  
**B 88.06 C 152.00**

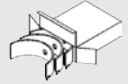

[15] Steel      [15] Acier      [15] Acciaio      [15] Acero

									
BE/PL	4	50.787/50.807	53.901/53.913	19.500	1.534	0.028/0.083	BS	4350CP	<b>71-4157/4</b> STD 0.25 0.50
MB/HL 1,2,4,5	4	52.985/53.005	56.717/56.730	20.750	1.841	0.030/0.088	AL-LF	66316RA	<b>H1043/5</b> STD 0.25 0.50 0.75
MB/HL 3	1	52.985/53.005	56.717/56.730	24.250	1.841	0.030/0.088	AL-LF	66317RA	
TW/A	2	59.000/59.250	73.600/73.850		2.362		BS	62037AF	<b>A201/2</b> STD .005
SE/PB	1	21.539/21.641	25.000/25.021	25.100			BS	66649Y	<b>55-4193</b> SEMI

## 1140

### 84.00

### Petrol



<b>834 C.000</b>	4 Cyl.	8:1	1995cc	<b>122kW (166)PS</b>	<b>Turbo Intercooled</b>	<b>TD1834</b>	<b>462</b>
<b>834 C.146</b>	4 Cyl.	8:1	1995cc	<b>110kW (150)PS</b>	<b>Turbo Intercooled</b>	<b>TD1837</b>	<b>463</b>

<p><b>87-215300-10</b> STD <b>87-215308-10</b> 0.60mm</p> <p>A 39.50 B- 4.50 D 79.00 22x69</p>	<p><b>08-215300-10</b> STD <b>08-215306-10</b> 0.40mm <b>08-215308-10</b> 0.60mm 02/88 →</p> <p>1.50 CR P 2.00 P 3.95 P</p>	<p><b>14-011041-00 D</b> B 88.06 C 152.00</p>	
<p><b>08-207600-00</b> STD <b>08-207604-00</b> 0.20mm <b>08-207606-00</b> 0.40mm <b>08-207608-00</b> 0.60mm</p> <p>1.50 CR P 2.00 P 3.95 CR [15]</p>			

[15] Steel      [15] Acier      [15] Acciaio      [15] Acero

BE/PL	4	50.787/50.807	53.892/53.910	19.500	1.537	0.020/0.070	BS	1040CP	<b>71-4118/4</b> STD 0.25 0.50
MB/HL 1,2,4,5	4	52.990/53.010	56.717/56.735	20.750	1.843	0.020/0.080	BS	4128CP	<b>H1084/5</b> STD 0.25 0.50
MB/HL 3	1	52.990/53.010	56.717/56.735	24.250	1.843	0.020/0.080	BS	4129CP	
TW/A	2	59.000/59.250	73.600/73.850		2.362		BS	62037AF	<b>A201/2</b> STD .005
SE/PB	1	21.539/21.641	25.000/25.021	25.100			BS	66649Y	<b>55-4193</b> SEMI

<b>JJ298</b> (Cork)	<b>JJ298</b>	<b>NB742</b> 30.00x43.00x8.00mm, ACM <b>NB732</b> 74.00x90.00x10.00mm, FPM







## 1141



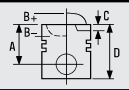
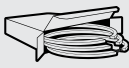



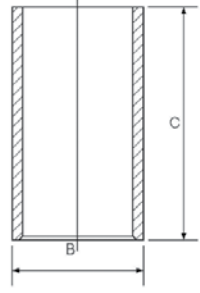

 84.00



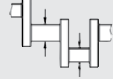
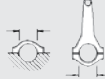



Petrol

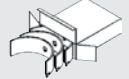



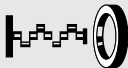







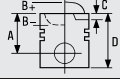
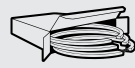

834 C.146      4 Cyl.      8:1      1995cc      110-112kW (150-152)PS      Turbo Intercooled      TD1064      464

			
	<p><b>08-142400-00</b> STD <b>08-142406-00</b> 0.40mm</p> <p>1.50  CK 1.50  P 3.00  P</p>	<p><b>14-011041-00 D</b> <b>B 88.06 C 152.00</b></p> 	

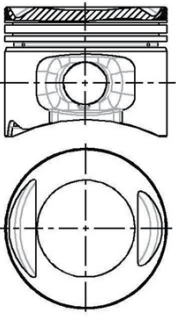







									
BE/PL	4	50.787/50.807	53.892/53.910	19.500	1.537	0.020/0.070	BS	1040CP	<b>71-4118/4</b> STD 0.25 0.50
MB/HL 1,2,4,5	4	52.990/53.010	56.717/56.735	20.750	1.843	0.020/0.080	BS	4128CP	<b>H1084/5</b> STD 0.25 0.50
MB/HL 3	1	52.990/53.010	56.717/56.735	24.250	1.843	0.020/0.080	BS	4129CP	
TW/A	2	59.000/59.250	73.600/73.850		2.362		BS	62037AF	<b>A201/2</b> STD .005
SE/PB	1	21.539/21.641	25.000/25.021	25.100			BS	66649Y	<b>55-4193</b> SEMI



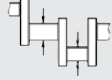
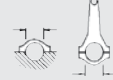



		
	<p><b>JJ413</b></p>  <p><b>JJ413</b></p>	<p><b>NB742</b>  30.00x43.00x8.00mm, ACM <b>NB732</b>  74.00x90.00x10.00mm, FPM</p>

<b>1142</b>	 <b>84.00</b>	<b>Petrol</b>	
<b>835 A5.000</b>	4 Cyl.	9.3:1	1995cc
			<b>86kW (117)PS</b>
			<b>TD14589 469</b>

			
<b>87-215300-00</b> STD <b>87-215306-00</b> 0.40mm <b>87-215308-00</b> 0.60mm  <b>A</b> 39.80 <b>B-</b> 1.60 <b>D</b> 67.80  22x63	  <b>08-215300-10</b> STD <b>08-215306-10</b> 0.40mm <b>08-215308-10</b> 0.60mm 02/88 →  1.50  CR P 2.00  P 3.95  P		
	<b>08-207600-00</b> STD <b>08-207604-00</b> 0.20mm <b>08-207606-00</b> 0.40mm <b>08-207608-00</b> 0.60mm  1.50  CR P 2.00  P 3.95  CR [15]		

[15] Steel                      [15] Acier                      [15] Acciaio                      [15] Acero

									
BE/PL	4	50.787/50.807	53.901/53.913	19.500	1.534	0.028/0.083	BS	4350CP	<b>71-4157/4</b> STD 0.25 0.50
MB/HL 1,2,4,5	4	52.985/53.005	56.717/56.730	20.750	1.841	0.030/0.088	AL-LF	66316RA	<b>H1043/5</b> STD 0.25 0.50 0.75
MB/HL 3	1	52.985/53.005	56.717/56.730	24.250	1.841	0.030/0.088	AL-LF	66317RA	
TW/A	2	59.000/59.250	73.600/73.850		2.362		BS	62037AF	<b>A201/2</b> STD .005
SE/PB	1	21.539/21.641	25.000/25.021	25.100			BS	66649Y	<b>55-4193</b> SEMI

		
	<b>JJ413</b>	<b>NB742</b>  30.00x43.00x8.00mm, ACM <b>NB732</b>  74.00x90.00x10.00mm, FPM
		
	<b>JJ413</b>	

## 1143

 **84.00**

**Petrol**



835 A5.046

4 Cyl.

9.3:1

1995cc

82-83kW (112-113)PS

TD1848

470

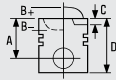

87-215300-10  
87-215308-10

STD  
0.60mm

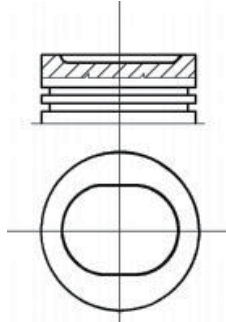

A 39.50  
B- 4.50  
D 79.00  
 22x69



08-215300-10 STD  
08-215306-10 0.40mm  
08-215308-10 0.60mm  
02/88 →

1.50  CR P  
2.00  P  
3.95  P

08-207600-00 STD  
08-207604-00 0.20mm  
08-207606-00 0.40mm  
08-207608-00 0.60mm

1.50  CR P  
2.00  P  
3.95  CR [15]

14-011041-00 D  
B 88.06 C 152.00

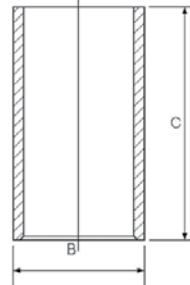







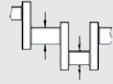

[15] Steel

[15] Acier

[15] Acciaio

[15] Acero

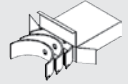
									
BE/PL	4	50.787/50.807	53.892/53.910	19.500	1.537	0.020/0.070	BS	1040CP	71-4118/4 STD 0.25 0.50
MB/HL 1,2,4,5	4	52.990/53.010	56.717/56.735	20.750	1.843	0.020/0.080	BS	4128CP	H1084/5 STD 0.25 0.50
MB/HL 3	1	52.990/53.010	56.717/56.735	24.250	1.843	0.020/0.080	BS	4129CP	
TW/A	2	59.000/59.250	73.600/73.850		2.362		BS	62037AF	A201/2 STD .005
SE/PB	1	21.539/21.641	25.000/25.021	25.100			BS	66649Y	55-4193 SEMI



JJ413

NP067  50.00x70.00x10.00mm, FPM



JJ413

1144		84.00		Petrol							
835 A8.000		4 Cyl.		1995cc		130-132kW (177-180)PS		Turbocharged		TD14588 472	
BE/PL	4	50.787/50.807	53.892/53.910	19.500	1.537	0.020/0.070	BS	1040CP	71-4118/4 STD 0.25 0.50		
MB/HL 1,2,4,5	4	52.990/53.010	56.717/56.735	20.750	1.843	0.020/0.080	BS	4128CP	H1084/5 STD 0.25 0.50		
MB/HL 3	1	52.990/53.010	56.717/56.735	24.250	1.843	0.020/0.080	BS	4129CP			
TW/A	2	59.000/59.250	73.600/73.850		2.362		BS	62037AF	A201/2 STD .005		
SE/PB	1	21.539/21.641	25.000/25.021	25.100			BS	66649Y	55-4193 SEMI		

JH111		NB742  30.00x43.00x8.00mm, ACM NB732  74.00x90.00x10.00mm, FPM
	JH111	

1145		84.00		Petrol							
835 A8.046		4 Cyl.		1995cc		119kW (162)PS		Turbocharged		TD1852 473	
BE/PL	4	50.787/50.807	53.901/53.913	19.500	1.534	0.028/0.083	BS	4350CP	71-4157/4 STD 0.25 0.50		
MB/HL 1,2,4,5	4	52.990/53.010	56.717/56.735	20.750	1.843	0.020/0.080	BS	4128CP	H1084/5 STD 0.25 0.50		
MB/HL 3	1	52.990/53.010	56.717/56.735	24.250	1.843	0.020/0.080	BS	4129CP			
TW/A	2	59.000/59.250	73.600/73.850		2.362		BS	62037AF	A201/2 STD .005		
SE/PB	1	21.539/21.641	25.000/25.021	25.100			BS	66649Y	55-4193 SEMI		

JH111		NB825  30.00x43.00x8.00mm, FPM NB732  74.00x90.00x10.00mm, FPM
	JH111	

# FIAT GROUP

## 1146

84.00

Petrol



836 A3.011

4 Cyl.

10.5:1

1995cc

102-104kW (139-141)PS

TD26168

477

BE/PL	4	50.787/50.807	53.901/53.913	19.500	1.534	0.028/0.083	BS	4350CP	71-4157/4 STD 0.25 0.50
MB/HL 1,2,4,5	4	52.990/53.010	56.717/56.735	20.750	1.843	0.020/0.080	BS	4128CP	H1084/5 STD 0.25 0.50
MB/HL 3	1	52.990/53.010	56.717/56.735	24.250	1.843	0.020/0.080	BS	4129CP	
TW/A	2	59.000/59.250	73.600/73.850		2.362		BS	62037AF	A201/2 STD .005
SE/PB	1	21.539/21.641	25.000/25.021	25.100			BS	66649Y	55-4193 SEMI

## 1147

84.00

Petrol



838 A4.000

4 Cyl.

8:1

1995cc

151kW (205)PS

Turbocharged

TD4619

478

87-142400-00 87-142406-00	STD 0.40mm		AK	08-142400-00 STD 08-142406-00 0.40mm	1.50 CK 1.50 P 3.00 P	14-011041-00 D B 88.06 C 152.00			

BE/PL	4	50.787/50.807	53.901/53.913	19.500	1.534	0.028/0.083	BS	4350CP	71-4157/4 STD 0.25 0.50
MB/HL 1,2,4,5	4	52.990/53.010	56.717/56.735	20.750	1.843	0.020/0.080	BS	4128CP	H1084/5 STD 0.25 0.50
MB/HL 3	1	52.990/53.010	56.717/56.735	24.250	1.843	0.020/0.080	BS	4129CP	
TW/A	2	59.000/59.250	73.600/73.850		2.362		BS	62037AF	A201/2 STD .005
SE/PB	1	21.539/21.641	25.000/25.021	25.100			BS	66649Y	55-4193 SEMI

JJ413	JJ413	NB742  30.00x43.00x8.00mm, ACM NB732  74.00x90.00x10.00mm, FPM
	JJ413	



## 1148

84.00

Petrol



6132 AZ 2.000

4 Cyl.

1995cc

59kW (80)PS

TD13508

479

BE/PL	4	50.782/50.802	53.897/53.913	19.500	1.537	0.021/0.082	AL-LF	66240RA	<b>01-4175/4</b> STD 0.25 0.50 0.75 1.00	
MB/HL 1,2,4,5	4	52.985/53.005	56.717/56.730	20.750	1.841	0.030/0.088	AL-LF	66316RA	<b>H1043/5</b> STD 0.25 0.50 0.75	
MB/HL 3	1	52.985/53.005	56.717/56.730	24.250	1.841	0.030/0.088	AL-LF	66317RA		
TW/A	2	59.000/59.250	73.600/73.850		2.362		BS	62037AF	<b>A201/2</b> STD .005	
SE/PB	1	21.539/21.641	25.000/25.021	25.100			BS	66649Y	<b>55-4193</b> SEMI	
SE/PB	1	21.539/21.641	23.939/23.972	25.100			BS	62039Y	<b>55-4288</b> SEMI	



JH111



JH111

## 1149

84.00

Petrol



AR 06416

4 Cyl.

1995cc

102-105kW (138-143)PS

TD62

422

AR 06420

4 Cyl.

1995cc

109kW (148)PS

TD63

422

<b>87-110200-30</b> STD  A 33.75 B+ 1.25 D 67.50 22x71			<b>08-110200-00</b> STD  1.50  CR P 1.50  P 3.50  P			<b>15-632000-00 WH [9]</b> B 89.00 C 152.00 D 98.00 E 107.50 			<b>89-110200-30</b> 87-110200-30 + 15-632000-00

[9] Includes seals

[9] Inclut des joints





[9] Comprende le guarnizioni







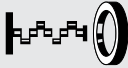



[9] Incluye los sellos

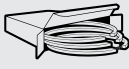



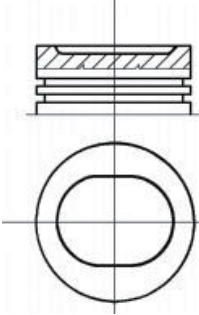



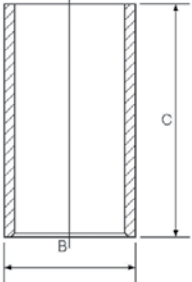

BE/PL	4	49.988/49.998	53.695/53.708	23.440	1.838	0.021/0.069	BS	60010CP	<b>71-4168/4</b> STD 0.25 0.50
MB/HL 1,3,5	3	59.960/59.973	63.657/63.676	25.530	1.837	0.020/0.067	BS	60011CP	<b>H1030/5</b> STD 0.25 0.50
MB/HL 2,4	2	59.960/59.973	63.657/63.676	18.360	1.837	0.020/0.067	BS	60012CP	
TW/A	4	65.786/66.040	82.423/82.677		2.362		AL-LF	2777AF	<b>A178/4</b> STD
SE/PB	1	21.994/22.000	25.120/25.146	23.720			BS	60014X	<b>55-4280</b> SEMI

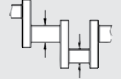



# FIAT GROUP

...Continued

<b>1149</b>	 <b>84.00</b>	<b>Petrol</b>
		
	<b>JJ451</b>	<b>NA5066</b>  35.00x50.00x10.00mm, ACM
		
	<b>JJ451</b>	

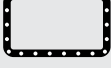
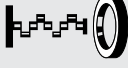
<b>1150</b>	 <b>84.00</b>	<b>Petrol</b>	
<b>AR 06476</b>	4 Cyl.	1995cc	<b>128-129kW (174-175)PS</b>
			<b>Turbocharged</b>
			<b>TD65 480</b>
			
<b>87-215300-10</b> <b>87-215308-10</b>	STD 0.60mm	<b>08-215300-10</b> STD <b>08-215306-10</b> 0.40mm <b>08-215308-10</b> 0.60mm	<b>14-011041-00 D</b> B 88.06 C 152.00
<b>A</b> 39.50 <b>B-</b> 4.50 <b>D</b> 79.00  22x69		1.50  CR P 2.00  P 3.95  P	

									
BE/PL	4	50.787/50.807	53.892/53.910	19.500	1.537	0.020/0.070	BS	1040CP	<b>71-4118/4</b> STD 0.25 0.50
MB/HL 1,2,4,5	4	52.990/53.010	56.717/56.735	20.750	1.843	0.020/0.080	BS	4128CP	<b>H1084/5</b> STD 0.25 0.50
MB/HL 3	1	52.990/53.010	56.717/56.735	24.250	1.843	0.020/0.080	BS	4129CP	
TW/A	2	59.000/59.250	73.600/73.850		2.362		BS	62037AF	<b>A201/2</b> STD .005
SE/PB	1	21.539/21.641	25.000/25.021	25.100			BS	66649Y	<b>55-4193</b> SEMI

		
	<b>JJ413</b>	<b>NB742</b>  30.00x43.00x8.00mm, ACM <b>NB732</b>  74.00x90.00x10.00mm, FPM
		
	<b>JJ413</b>	

<b>1151</b>	<b>84.00</b>	<b>Petrol</b>	
<b>AR 64103</b>	4 Cyl.	1995cc	<b>106kW (144)PS</b>
<b>AR 67201</b>	4 Cyl.	10:1	<b>106kW (144)PS</b>
			<b>TD129 412</b>
			<b>TD136 481</b>

	<b>08-110200-00</b> STD 1.50  CR P 1.50  P 3.50  P	<b>15-632000-00 WH [9]</b> <b>B 89.00 C 152.00 D 98.00 E 107.50</b> 	

[9] Includes seals      [9] Inclut des joints      [9] Comprende le guarnizioni      [9] Incluye los sellos

BE/PL	4	49.988/49.998	53.695/53.708	23.440	1.838	0.021/0.069	BS	60010CP	<b>71-4168/4</b> STD 0.25 0.50
MB/HL 1,3,5	3	59.960/59.973	63.657/63.676	25.530	1.837	0.020/0.067	BS	60011CP	<b>H1030/5</b> STD 0.25 0.50
MB/HL 2,4	2	59.960/59.973	63.657/63.676	18.360	1.837	0.020/0.067	BS	60012CP	
TW/A	4	65.786/66.040	82.423/82.677		2.362		AL-LF	2777AF	<b>A178/4</b> STD
SE/PB	1	21.994/22.000	25.120/25.146	23.720			BS	60014X	<b>55-4280</b> SEMI

	<b>HR397</b>	<b>NA5066</b> 35.00x50.00x10.00mm, ACM <b>NA5065</b> 62.00x80.00x12.00mm, ACM









<b>1152</b>	<b>84.00</b>	<b>Petrol</b>	
<b>AR 67203</b>	4 Cyl.	1995cc	<b>137-140kW (186-190)PS</b>
			<b>Turbocharged</b>
			<b>TD138 482</b>

<b>87-142400-00</b> STD <b>87-142406-00</b> 0.40mm  <b>A</b> 39.00 <b>B-</b> 6.00 <b>BØ</b> 72.00 <b>C</b> 2.00 <b>D</b> 69.00 22x69  <b>AK</b>	<b>08-142400-00</b> STD <b>08-142406-00</b> 0.40mm  1.50  CK 1.50  P 3.00  P	<b>14-011041-00 D</b> <b>B 88.06 C 152.00</b> 	

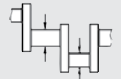
# FIAT GROUP

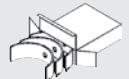

...Continued

## 1152 85.00 Petrol

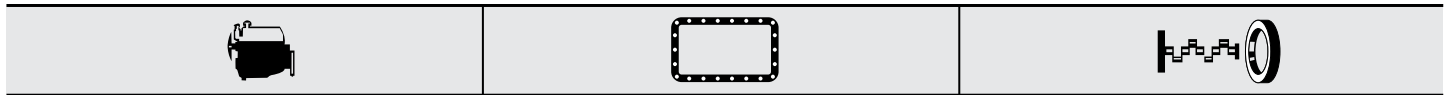
									
BE/PL	4	50.787/50.807	53.901/53.913	19.500	1.534	0.028/0.083	BS	4350CP	<b>71-4157/4</b> STD 0.25 0.50
MB/HL 1,2,4,5	4	52.990/53.010	56.717/56.735	20.750	1.843	0.020/0.080	BS	4128CP	<b>H1084/5</b> STD 0.25 0.50
MB/HL 3	1	52.990/53.010	56.717/56.735	24.250	1.843	0.020/0.080	BS	4129CP	
TW/A	2	59.000/59.250	73.600/73.850		2.362		BS	62037AF	<b>A201/2</b> STD .005
SE/PB	1	21.539/21.641	25.000/25.021	25.100			BS	66649Y	<b>55-4193</b> SEMI



JJ413

**NB825**  30.00x43.00x8.00mm, FPM  
**NB732**  74.00x90.00x10.00mm, FPM





JJ413

## 1153 85.00 Diesel

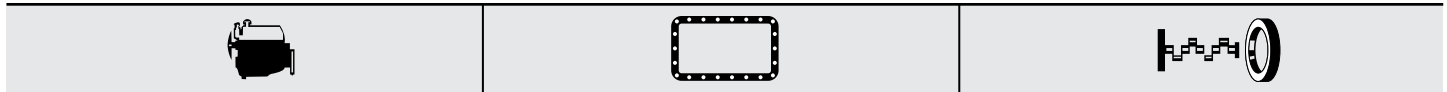
4HP	4 Cyl.	2179cc	120kW (163)PS	Turbo Intercooled	<b>TD24689</b>	<b>501</b>	
4HP	4 Cyl.	2179cc	120kW (163)PS	Turbo Intercooled	<b>TD24945</b>	<b>501</b>	
RH02	4 Cyl.	17.5:1	1997cc	94kW (128)PS	Turbo Intercooled	<b>TD26194</b>	<b>488</b>



HR397

**NA5191**  42.00x62.00x7.00mm, PTFE  
**NA5192**  90.00x110.00x7.00mm, PTFE

## 1154 85.00 Diesel

DW10BTED4	4 Cyl.	17.6:1	1997cc	100kW (136)PS	Turbo Intercooled	<b>TD25755</b>	<b>483</b>
-----------	--------	--------	--------	---------------	-------------------	----------------	------------

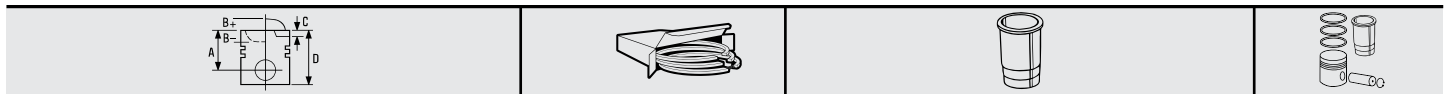







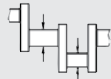
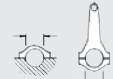

**08-114700-00** STD  
**08-114708-00** 0.60mm

3.50  CK P  
2.00  P  
3.00  CR P

...Continued

**1154**  **85.00 Diesel**

									
BE/PL	4	49.984/50.000	53.695/53.708	20.000	1.838	0.020/0.070	SP	71-3952	<b>71-3952/4</b> STD 0.30 [21]
MB/HL	1	76.187/76.200	80.587/80.607	25.000	2.172	0.043/0.101	BS	66631CPA	<b>72-4547</b> STD 0.25 0.50 0.75 1.00
MB/HL	1	76.187/76.200	80.587/80.607	25.000	2.172	0.043/0.101	BS	60076CP	<b>72-4550</b> STD 0.25
MB/HL 1-5	5	59.981/60.000	63.731/63.750	20.290	1.845	0.040/0.100	AL-LF	66726RA	<b>H1057/5</b> STD 0.30 0.50



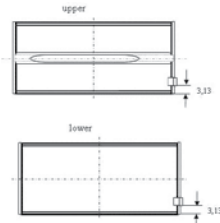

**66631CPA**

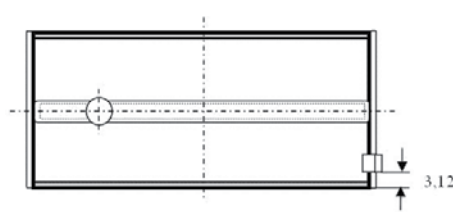

**60076CP**













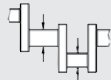
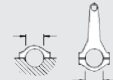



TW/A	4	67.050/67.300	83.050/83.300		2.330		BS	66721BF	<b>A214/4</b> STD 0.10
SE/PB	1	27.997/28.000	30.200/30.225	24.050			BS-LF	55-3985	<b>55-3985</b> SEMI

		
	<b>HR397</b>	<b>NA5191</b>  42.00x62.00x7.00mm, PTFE <b>NA5192</b>  90.00x110.00x7.00mm, PTFE



**1155**  **85.00 Petrol**









**RFH (EW10A) Euro 4 (D4)** 4 Cyl. 11:1 1997cc **103kW (140)PS** **TD25732 484**

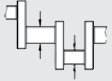
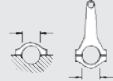

									
BE/PL	4	44.975/44.991	48.655/48.671	22.500	1.825	0.020/0.070	AL	4300RA	<b>01-4155/4</b> STD 0.30
MB/HL 1-5	5	59.981/60.000	63.708/63.727	21.000	1.844	0.020/0.083	AL-LF	02-3957	<b>H086/5</b> STD
TW/A	2	67.050/67.300	83.050/83.300		2.330		AL	04-3980	<b>A161/2</b> STD
CB/NWB	4	27.982/28.000	31.200/31.218	18.150	1.594		AL-LF	03-3981	<b>N151/6</b> STD
CB/NWB	8	27.982/28.000	31.200/31.218	18.150	1.594		AL-LF	03-3982	



		
	<b>HR397</b>	<b>NA5191</b>  42.00x62.00x7.00mm, PTFE <b>NA5192</b>  90.00x110.00x7.00mm, PTFE

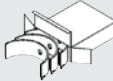



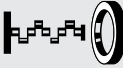
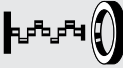



# FIAT GROUP

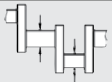
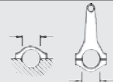

<b>1156</b>	 <b>85.00</b>	<b>Petrol</b>				
<b>RFN (EW10J4)</b>	4 Cyl.	10.8:1	1997cc	<b>100kW (136)PS</b>	<b>TD16734</b>	<b>486</b>
<b>RFN (EW10J4)</b>	4 Cyl.	10.8:1	1997cc	<b>100kW (136)PS</b>	<b>TD16788</b>	<b>485</b>



									
BE/PL	4	44.975/44.991	48.655/48.671	22.500	1.825	0.020/0.070	AL	4300RA	<b>01-4155/4</b> STD 0.30
MB/HL 1-5	5	59.981/60.000	63.708/63.727	21.000	1.844	0.020/0.083	AL-LF	02-3957	<b>H086/5</b> STD
TW/A	2	67.050/67.300	83.050/83.300		2.330		AL	04-3980	<b>A161/2</b> STD
CB/NWB	4	27.982/28.000	31.200/31.218	18.150	1.594		AL-LF	03-3981	<b>N151/6</b> STD
CB/NWB	8	27.982/28.000	31.200/31.218	18.150	1.594		AL-LF	03-3982	

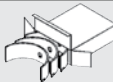



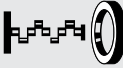
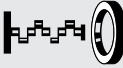



		
<b>EG9750</b>	<b>HR397</b>	<b>NA5256</b>  40.00x55.00x6.50mm, FPM

<b>1157</b>	 <b>85.00</b>	<b>Petrol</b>				
<b>RFN</b>	4 Cyl.	10.8:1	1997cc	<b>100kW (136)PS</b>	<b>TD16322</b>	<b>487</b>

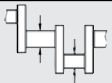
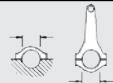





									
BE/PL	4	44.975/44.991	48.655/48.671	22.500	1.825	0.020/0.070	AL	4300RA	<b>01-4155/4</b> STD 0.30
MB/HL 1-5	5	59.981/60.000	63.708/63.727	21.000	1.844	0.020/0.083	AL-LF	02-3957	<b>H086/5</b> STD
TW/A	2	67.050/67.300	83.050/83.300		2.330		AL	04-3980	<b>A161/2</b> STD



		
<b>EG9750</b>	<b>HR397</b>	<b>NA5256</b>  40.00x55.00x6.50mm, FPM









<b>1158</b>	 <b>85.00</b>	<b>Diesel</b>					
<b>RHH Euro 5</b>	4 Cyl.	16:1	1997cc	<b>120kW (163)PS</b>	<b>Turbo Intercooled</b>	<b>TD24777</b>	<b>488</b>

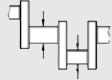
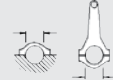

									
BE/PL	4	49.984/50.000	53.695/53.708	20.000	1.838	0.020/0.070	SP	71-3952	<b>71-3952/4</b> STD 0.30 [21]
MB/HL 1-5	5	59.981/60.000	63.731/63.750	20.290	1.845	0.040/0.100	AL-LF	66726RA	<b>H1057/5</b> STD 0.30 0.50
TW/A	4	67.050/67.300	83.050/83.300		2.330		BS	66721BF	<b>A214/4</b> STD 0.10
SE/PB	1	27.997/28.000	30.200/30.225	24.050			BS-LF	55-3985	<b>55-3985</b> SEMI













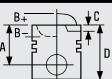



...Continued



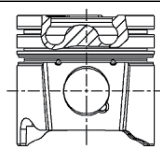
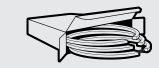

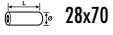
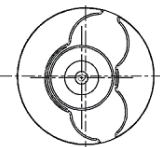



<b>1158</b>	 <b>85.00</b>	<b>Diesel</b>
		
	<b>HR397</b>	<b>NA5191</b>  42.00x62.00x7.00mm, PTFE <b>NA5192</b>  90.00x110.00x7.00mm, PTFE

<b>1159</b>	 <b>85.00</b>	<b>Diesel</b>					
<b>RHK (DW10UTED4) Euro 4 (D4)</b>	4 Cyl.	17.5:1	1997cc	<b>79-88kW (107-120)PS</b>	<b>Turbo Intercooled</b>	<b>TD26952</b>	<b>483</b>
<b>RHM (DW10ATED4)</b>	4 Cyl.	17.6:1	1997cc	<b>79kW (107)PS</b>	<b>Turbo Intercooled</b>	<b>TD26957</b>	<b>491</b>
<b>RHZ (DW10ATED)</b>	4 Cyl.	18:1	1997cc	<b>80kW (109)PS</b>	<b>Turbocharged</b>	<b>TD26954</b>	<b>498</b>

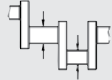
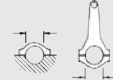
									
BE/PL	4	49.984/50.000	53.695/53.708	20.000	1.838	0.020/0.070	SP	71-3952	<b>71-3952/4</b> STD 0.30 [21]
MB/HL 1-5	5	59.981/60.000	63.731/63.750	20.290	1.845	0.040/0.100	AL-LF	66726RA	<b>H1057/5</b> STD 0.30 0.50
TW/A	4	67.050/67.300	83.050/83.300		2.330		BS	66721BF	<b>A214/4</b> STD 0.10
SE/PB	1	27.997/28.000	30.200/30.225	24.050			BS-LF	55-3985	<b>55-3985</b> SEMI
CB/NWB	4	27.982/28.000	31.200/31.218	18.150	1.594		AL-LF	03-3981	<b>N151/6</b> STD
CB/NWB	8	27.982/28.000	31.200/31.218	18.150	1.594		AL-LF	03-3982	





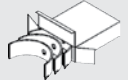

<b>1160</b>	 <b>85.00</b>	<b>Diesel</b>					
<b>RHK</b>	4 Cyl.	17.5:1	1997cc	<b>88kW (120)PS</b>	<b>Turbo Intercooled</b>	<b>TD20267</b>	<b>489</b>



									
<b>87-114700-40</b>	STD		<b>08-114700-00</b> STD <b>08-114708-00</b> 0.60mm						
<b>A</b> 46.71 <b>B-</b> 15.40 <b>BØ</b> 44.80 <b>C</b> 0.57 <b>D</b> 72.71  28x70			<b>3.50</b>  CK P <b>2.00</b>  P <b>3.00</b>  CR P						
<b>AK KK RT TP</b>									

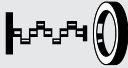







									
BE/PL	4	49.984/50.000	53.695/53.708	20.000	1.838	0.020/0.070	SP	71-3952	<b>71-3952/4</b> STD 0.30 [21]
MB/HL 1-5	5	59.981/60.000	63.731/63.750	20.290	1.845	0.040/0.100	AL-LF	66726RA	<b>H1057/5</b> STD 0.30 0.50
TW/A	4	67.050/67.300	83.050/83.300		2.330		BS	66721BF	<b>A214/4</b> STD 0.10
SE/PB	1	27.997/28.000	30.200/30.225	24.050			BS-LF	55-3985	<b>55-3985</b> SEMI
CB/NWB	4	27.982/28.000	31.200/31.218	18.150	1.594		AL-LF	03-3981	<b>N151/6</b> STD
CB/NWB	8	27.982/28.000	31.200/31.218	18.150	1.594		AL-LF	03-3982	

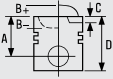







# FIAT GROUP



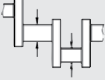
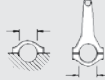



...Continued



<b>1160</b>	 <b>85.00</b>	<b>Diesel</b>
		
 ED5500	HR397	<b>NA5191</b>  42.00x62.00x7.00mm, PTFE <b>NA5192</b>  90.00x110.00x7.00mm, PTFE







<b>1161</b>	 <b>85.00</b>	<b>Diesel</b>				
<b>RHM (DW10ATED4)</b>	4 Cyl.	1997cc	<b>79kW (107)PS</b>	<b>Turbo Intercooled</b>	<b>TD18906</b>	<b>490</b>

			
<b>87-114700-10</b> STD <b>87-114708-10</b> 0.60mm  <b>A</b> 46.73 <b>B-</b> 18.80 <b>BØ</b> 39.80 <b>C</b> 1.67 <b>D</b> 72.70  28x68  <b>AK KK RT TP</b>  <b>08517-103</b>	  <b>08-114700-00</b> STD <b>08-114708-00</b> 0.60mm  <b>3.50</b>  CK P <b>2.00</b>  P <b>3.00</b>  CR P		

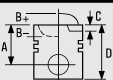
									
BE/PL	4	49.984/50.000	53.695/53.708	20.000	1.838	0.020/0.070	SP	71-3952	<b>71-3952/4</b> STD 0.30 [21]
MB/HL 1-5	5	59.981/60.000	63.731/63.750	20.290	1.845	0.040/0.100	AL-LF	66726RA	<b>H1057/5</b> STD 0.30 0.50
TW/A	4	67.050/67.300	83.050/83.300		2.330		BS	66721BF	<b>A214/4</b> STD 0.10
SE/PB	1	27.997/28.000	30.200/30.225	24.050			BS-LF	55-3985	<b>55-3985</b> SEMI
CB/NWB	4	27.982/28.000	31.200/31.218	18.150	1.594		AL-LF	03-3981	<b>N151/6</b> STD
CB/NWB	8	27.982/28.000	31.200/31.218	18.150	1.594		AL-LF	03-3982	













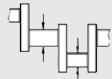
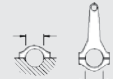

		
 ED5500	HR397	<b>NA5191</b>  42.00x62.00x7.00mm, PTFE <b>NA5192</b>  90.00x110.00x7.00mm, PTFE



<b>1162</b>	 <b>85.00</b>	<b>Diesel</b>					
<b>RHR</b>	4 Cyl.	18:1	1997cc	<b>100kW (136)PS</b>	<b>Turbo Intercooled</b>	<b>TD20268</b>	<b>493</b>
<b>RHR (DW10BTED4) Euro 4 (D4)</b>	4 Cyl.	18:1	1997cc	<b>100kW (136)PS</b>	<b>Turbo Intercooled</b>	<b>TD26955</b>	<b>492</b>
<b>RHW (DW10ATED4)</b>	4 Cyl.	18:1	1997cc	<b>80kW (109)PS</b>	<b>Turbo Intercooled</b>	<b>TD16789</b>	<b>495</b>







			
	<b>08-114700-00</b> STD <b>08-114708-00</b> 0.60mm  <b>3.50</b>  CK P <b>2.00</b>  P <b>3.00</b>  CR P		



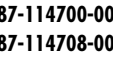
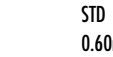





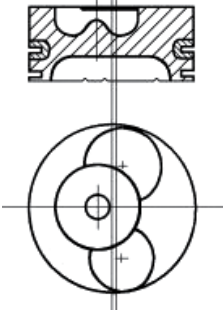



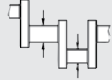
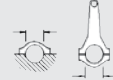



...Continued

<b>1162</b>		 <b>85.00</b>		<b>Diesel</b>						
										[21]
BE/PL	4	49.984/50.000	53.695/53.708	20.000	1.838	0.020/0.070	SP	71-3952	<b>71-3952/4</b> STD 0.30	
MB/HL 1-5	5	59.981/60.000	63.731/63.750	20.290	1.845	0.040/0.100	AL-LF	66726RA	<b>H1057/5</b> STD 0.30 0.50	
TW/A	4	67.050/67.300	83.050/83.300		2.330		BS	66721BF	<b>A214/4</b> STD 0.10	
SE/PB	1	27.997/28.000	30.200/30.225	24.050			BS-LF	55-3985	<b>55-3985</b> SEMI	
CB/NWB	4	27.982/28.000	31.200/31.218	18.150	1.594		AL-LF	03-3981	<b>N151/6</b> STD	
CB/NWB	8	27.982/28.000	31.200/31.218	18.150	1.594		AL-LF	03-3982		
										
ED5500			HR397			NA5191  42.00x62.00x7.00mm, PTFE NA5192  90.00x110.00x7.00mm, PTFE				

<b>1163</b>		 <b>85.00</b>		<b>Diesel</b>						
RHV (DW10)		4 Cyl.	18:1	1997cc	62kW (84)PS	Turbo Intercooled		TD16406	494	

					
87-114700-00	87-114708-00	08-114700-00	08-114708-00		
STD	STD	STD	STD		
0.60mm	0.60mm	0.60mm	0.60mm		
A 46.75		3.50	CK P		
B- 18.30		2.00	P		
BØ 38.00		3.00	CR P		
C 1.00					
D 80.75					
 28x70					
AK RT TP					
					
08570-109					

<b>1163</b>		 <b>85.00</b>		<b>Diesel</b>						
										[21]
BE/PL	4	49.984/50.000	53.695/53.708	20.000	1.838	0.020/0.070	SP	71-3952	<b>71-3952/4</b> STD 0.30	
MB/HL 1-5	5	59.981/60.000	63.731/63.750	20.290	1.845	0.040/0.100	AL-LF	66726RA	<b>H1057/5</b> STD 0.30 0.50	
TW/A	4	67.050/67.300	83.050/83.300		2.330		BS	66721BF	<b>A214/4</b> STD 0.10	
SE/PB	1	27.997/28.000	30.200/30.225	24.050			BS-LF	55-3985	<b>55-3985</b> SEMI	
CB/NWB	4	27.982/28.000	31.200/31.218	18.150	1.594		AL-LF	03-3981	<b>N151/6</b> STD	
CB/NWB	8	27.982/28.000	31.200/31.218	18.150	1.594		AL-LF	03-3982		
										
EA5830			HR397			NA5191  42.00x62.00x7.00mm, PTFE NA5192  90.00x110.00x7.00mm, PTFE				

# FIAT GROUP

## 1164



85.00

Diesel



RHW (DW10ATED4)

4 Cyl.

17.1:1

1997cc

80kW (109)PS

Turbo Intercooled

TD16735

496

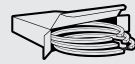
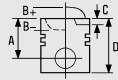

87-114700-10  
87-114708-10

STD  
0.60mm

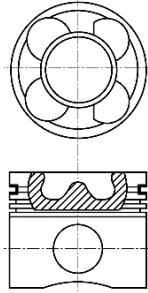

08-114700-00 STD  
08-114708-00 0.60mm

3.50 CK P  
2.00 P  
3.00 CR P

A 46.73  
B- 18.80  
BØ 39.80  
C 1.67  
D 72.70  
28x68

AK KK RT TP

08517-103

BE/PL	4	49.984/50.000	53.695/53.708	20.000	1.838	0.020/0.070	SP	71-3952	71-3952/4 [21] STD 0.30
MB/HL 1-5	5	59.981/60.000	63.731/63.750	20.290	1.845	0.040/0.100	AL-LF	66726RA	H1057/5 STD 0.30 0.50
TW/A	4	67.050/67.300	83.050/83.300		2.330		BS	66721BF	A214/4 STD 0.10
SE/PB	1	27.997/28.000	30.200/30.225	24.050			BS-LF	55-3985	55-3985 SEMI
CB/NWB	4	27.982/28.000	31.200/31.218	18.150	1.594		AL-LF	03-3981	N151/6 STD
CB/NWB	8	27.982/28.000	31.200/31.218	18.150	1.594		AL-LF	03-3982	



HR397

NA5191 42.00x62.00x7.00mm, PTFE

## 1165



85.00

Diesel



RHX

4 Cyl.

17.6:1

1997cc

69kW (94)PS

Turbo Intercooled

TD16299

497

RHZ

4 Cyl.

17.6:1

1997cc

80kW (109)PS

Turbo Intercooled

TD16324

497

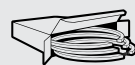
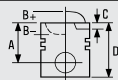

87-114700-00  
87-114708-00

STD  
0.60mm

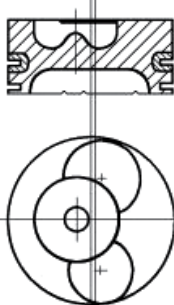

08-114700-00 STD  
08-114708-00 0.60mm













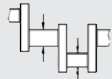
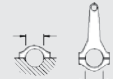

3.50 CK P  
2.00 P  
3.00 CR P



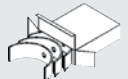





A 46.75  
B- 18.30  
BØ 38.00  
C 1.00  
D 80.75  
28x70



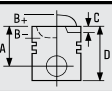
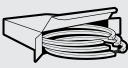

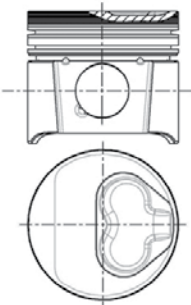







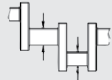
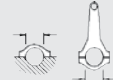

AK RT TP

08570-109

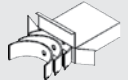
...Continued

<b>1165</b>		 <b>85.00</b>	<b>Diesel</b>								
											
BE/PL	4	49.984/50.000	53.695/53.708	20.000	1.838	0.020/0.070	SP	71-3952	<b>71-3952/4</b> STD 0.30	[21]	
MB/HL 1-5	5	59.981/60.000	63.731/63.750	20.290	1.845	0.040/0.100	AL-LF	66726RA	<b>H1057/5</b> STD 0.30 0.50		
TW/A	4	67.050/67.300	83.050/83.300		2.330		BS	66721BF	<b>A214/4</b> STD 0.10		
SE/PB	1	27.997/28.000	30.200/30.225	24.050			BS-LF	55-3985	<b>55-3985</b> SEMI		
CB/NWB	4	27.982/28.000	31.200/31.218	18.150	1.594		AL-LF	03-3981	<b>N151/6</b> STD		
CB/NWB	8	27.982/28.000	31.200/31.218	18.150	1.594		AL-LF	03-3982			
											
 <b>EA5830</b>			<b>HR397</b> → <b>KG5157</b> 10.00x20.00x2.000mm → <b>PB907</b> 14.00x21.00x2.000mm				<b>NA5191</b>  42.00x62.00x7.00mm, PTFE <b>NA5192</b>  90.00x110.00x7.00mm, PTFE				

<b>1166</b>		 <b>85.00</b>	<b>Diesel</b>								
<b>P 8 C</b>		4 Cyl.	21.5:1	2088cc	80kW (109)PS	<b>Turbocharged</b>		<b>TD1859</b>	<b>500</b>		
											
<b>87-126608-00</b>	0.60mm				<b>08-126600-00</b> STD						
<b>A</b> 44.95					<b>08-126608-00</b> 0.60mm						
<b>B-</b> 2.70					3.00  CK P						
<b>D</b> 74.80					2.00  NT						
 30x72					3.00  CR						
<b>HA KK RT TP</b>											

<b>1166</b>		 <b>85.00</b>	<b>Diesel</b>								
											
BE/PL	4	49.984/50.000	53.695/53.708	21.950	1.843	0.020/0.064	BS	4255CP	<b>71-4279/4</b> STD 0.30		
MB/HL 1-5	5	59.981/60.000	63.731/63.750	20.290	1.845	0.040/0.100	AL-LF	66726RA	<b>H1057/5</b> STD 0.30 0.50		
TW/A	4	67.050/67.300	83.050/83.300		1.880		AL-LF	4141AF	<b>A188/4</b> STD		
											
 <b>EV150</b>			<b>JJ283</b> [20] 				<b>NA5191</b>  42.00x62.00x7.00mm, PTFE				
			<b>JJ283</b>								

[20] Oil Pan Material: Steel

[20] Matériel pour carter d'huile: acier

[20] Materiale coppa olio: Acciaio

[20] Material cárter: Acero









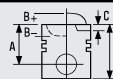
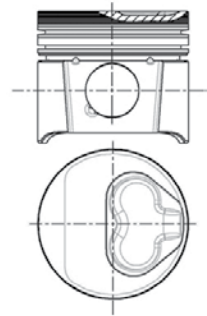
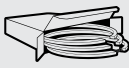

## 1167









 85.00



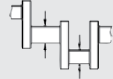



**Diesel**

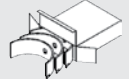

**P8C**      4 Cyl.      21.5:1      2088cc      **80kW (109)PS**      **Turbo Intercooled**      **TD960**      **499**

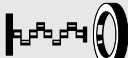
				
<p><b>87-126608-00</b>      0.60mm</p> <p><b>A</b>    44.95 <b>B-</b>    2.70 <b>D</b>    74.80</p> <p> 30x72</p> <p><b>HA KK RT TP</b></p>	<p><b>08-126600-00</b>    STD <b>08-126608-00</b>    0.60mm</p> <p>3.00  CK P 2.00  NT 3.00  CR</p> <p><b>08-154900-00</b>    STD <b>08-154908-00</b>    0.60mm</p> <p>3.00  P PS 2.00  P 3.00  CR P</p>			

									
BE/PL	4	49.984/50.000	53.695/53.708	21.950	1.843	0.020/0.064	BS	4255CP	<b>71-4279/4</b> STD 0.30
MB/HL 1-5	5	59.981/60.000	63.731/63.750	20.290	1.845	0.040/0.100	AL-LF	66726RA	<b>H1057/5</b> STD 0.30 0.50
TW/A	4	67.050/67.300	83.050/83.300		1.880		AL-LF	4141AF	<b>A188/4</b> STD



		
<p><b>EV150</b></p>	<p><b>JJ283</b> [20] (Steel) = <b>PA349</b> 22.00x16.00x2.000mm = <b>PB907</b> 14.00x21.00x2.000mm</p>  <p><b>JJ283</b></p>	<p><b>NA5191</b>  42.00x62.00x7.00mm, PTFE <b>NA5192</b>  90.00x110.00x7.00mm, PTFE</p>









[20] Oil Pan Material: Steel



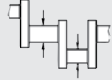
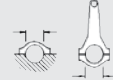

[20] Matériel pour carter d'huile: acier

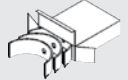

[20] Materiale coppa olio: Acciaio







[20] Material cárter: Acero



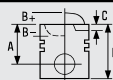
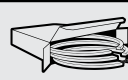

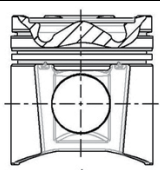
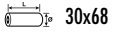



<b>1168</b>		<b>85.00</b>	<b>Diesel</b>				
<b>4HR</b>	4 Cyl.	2179cc	<b>120kW (163)PS</b>	<b>Turbo Intercooled</b>	<b>TD24690</b>	<b>501</b>	
<b>4HR</b>	4 Cyl.	2179cc	<b>120kW (163)PS</b>	<b>Turbo Intercooled</b>	<b>TD24946</b>	<b>501</b>	
<b>4HS Euro 4 (D4)</b>	4 Cyl.	16.6:1	2179cc	<b>125kW (170)PS</b>	<b>Turbo Intercooled</b>	<b>TD24688</b>	<b>501</b>
<b>4HS Euro 4 (D4)</b>	4 Cyl.	16.6:1	2179cc	<b>125kW (170)PS</b>	<b>Turbo Intercooled</b>	<b>TD24775</b>	<b>501</b>
<b>4HT (DW12BTED4) Euro 4 (D4)</b>	4 Cyl.	16.6:1	2179cc	<b>125kW (170)PS</b>	<b>Bi-Turbocharged Intercooled</b>	<b>TD25656</b>	<b>502</b>
<b>4HT Euro 4 (D4)</b>	4 Cyl.	17.5:1	2179cc	<b>125kW (170)PS</b>	<b>Bi-Turbocharged Intercooled</b>	<b>TD24686</b>	<b>503</b>

									
BE/PL	4	49.984/50.000	53.695/53.708	20.000	1.838	0.020/0.070	SP	71-3952	<b>71-3952/4</b> STD 0.30 [21]
MB/HL 1-5	5	59.981/60.000	63.731/63.750	20.290	1.845	0.040/0.100	AL-LF	66726RA	<b>H1057/5</b> STD 0.30 0.50
TW/A	4	67.050/67.300	83.050/83.300		2.330		BS	66721BF	<b>A214/4</b> STD 0.10
SE/PB	1	29.995/30.000	33.000/33.025	24.050			BS-LF	55-3984	<b>55-3984</b> SEMI
CB/NWB	4	27.982/28.000	31.200/31.218	18.150	1.594		AL-LF	03-3981	<b>N151/6</b> STD
CB/NWB	8	27.982/28.000	31.200/31.218	18.150	1.594		AL-LF	03-3982	

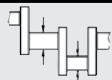
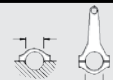
		
	<b>HR397</b>	<b>NA5191</b>  42.00x62.00x7.00mm, PTFE <b>NA5192</b>  90.00x110.00x7.00mm, PTFE





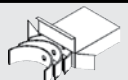

<b>1169</b>		<b>85.00</b>	<b>Diesel</b>				
<b>4HW (DW12ATED4)</b>	4 Cyl.	18:1	2179cc	<b>94kW (128)PS</b>	<b>Turbo Intercooled</b>	<b>TD16790</b>	<b>505</b>



			
<b>87-114700-30</b> <b>87-114708-30</b>	STD 0.60mm		<b>08-114700-00</b> STD <b>08-114708-00</b> 0.60mm
<b>A</b> 48.70 <b>B-</b> 18.00 <b>BØ</b> 40.80 <b>C</b> 0.40 <b>C</b> 0.40 <b>D</b> 77.70  30x68		<b>3.50</b>  CK P <b>2.00</b>  P <b>3.00</b>  CR P	
<b>AK KK RT</b>			

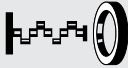

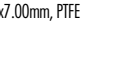





									
BE/PL	4	49.984/50.000	53.695/53.708	20.000	1.838	0.020/0.070	SP	71-3952	<b>71-3952/4</b> STD 0.30 [21]
MB/HL 1-5	5	59.981/60.000	63.731/63.750	20.290	1.845	0.040/0.100	AL-LF	66726RA	<b>H1057/5</b> STD 0.30 0.50
TW/A	4	67.050/67.300	83.050/83.300		2.330		BS	66721BF	<b>A214/4</b> STD 0.10
SE/PB	1	29.995/30.000	33.000/33.025	24.050			BS-LF	55-3984	<b>55-3984</b> SEMI
CB/NWB	4	27.982/28.000	31.200/31.218	18.150	1.594		AL-LF	03-3981	<b>N151/6</b> STD
CB/NWB	8	27.982/28.000	31.200/31.218	18.150	1.594		AL-LF	03-3982	

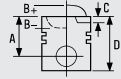

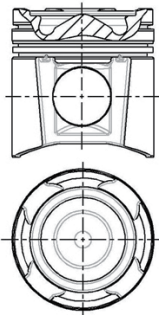





# FIAT GROUP



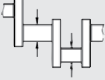
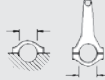

...Continued



<b>1169</b>	 <b>85.00</b>	<b>Diesel</b>
 ED5490	 HR397	 NA5191   NA5192 

<b>1170</b>	 <b>85.00</b>	<b>Diesel</b>					
<b>4HW(DW12ATED4)</b>	4 Cyl.	18:1	2179cc	<b>94kW (128)PS</b>	<b>Turbo Intercooled</b>	<b>TD16736</b>	<b>504</b>







 <b>87-114700-30</b> STD <b>87-114708-30</b> 0.60mm  <b>A</b> 48.70 <b>B-</b> 18.00 <b>BØ</b> 40.80 <b>C</b> 0.40 <b>C</b> 0.40 <b>D</b> 77.70  30x68   AK KK RT		 <b>08-114700-00</b> STD <b>08-114708-00</b> 0.60mm  <b>3.50</b>  CK P <b>2.00</b>  P <b>3.00</b>  CR P		
---	---	---	---	---



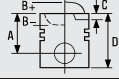
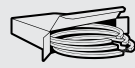





									
BE/PL	4	49.984/50.000	53.695/53.708	20.000	1.838	0.020/0.070	SP	71-3952	<b>71-3952/4</b> [21] STD 0.30
MB/HL 1-5	5	59.981/60.000	63.731/63.750	20.290	1.845	0.040/0.100	AL-LF	66726RA	<b>H1057/5</b> STD 0.30 0.50
TW/A	4	67.050/67.300	83.050/83.300		2.330		BS	66721BF	<b>A214/4</b> STD 0.10
SE/PB	1	29.995/30.000	33.000/33.025	24.050			BS-LF	55-3984	<b>55-3984</b> SEMI
CB/NWB	4	27.982/28.000	31.200/31.218	18.150	1.594		AL-LF	03-3981	<b>N151/6</b> STD
CB/NWB	8	27.982/28.000	31.200/31.218	18.150	1.594		AL-LF	03-3982	

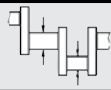

 ED5490	 HR397	 NA5191 
---	---	--

**1171**  **85.00 Diesel** 

**4HX (DW12TED4)** 4 Cyl. 18:1 2179cc **94-100kW (128-136)PS** Turbo Intercooled **TD22230**

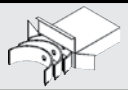







			
<b>87-114700-30</b> <b>87-114708-30</b> STD 0.60mm  <b>A</b> 48.70 <b>B-</b> 18.00 <b>B0</b> 40.80 <b>C</b> 0.40 <b>C</b> 0.40 <b>D</b> 77.70  30x68  <b>AK KK RT</b>	<b>08-114700-00</b> STD <b>08-114708-00</b> 0.60mm  3.50  CK P 2.00  P 3.00  CR P		

									
BE/PL	4	49.984/50.000	53.695/53.708	20.000	1.838	0.020/0.070	SP	71-3952	<b>71-3952/4</b> [21] STD 0.30
MB/HL 1-5	5	59.981/60.000	63.731/63.750	20.290	1.845	0.040/0.100	AL-LF	66726RA	<b>H1057/5</b> STD 0.30 0.50
TW/A	4	67.050/67.300	83.050/83.300		2.330		BS	66721BF	<b>A214/4</b> STD 0.10
SE/PB	1	29.995/30.000	33.000/33.025	24.050			BS-LF	55-3984	<b>55-3984</b> SEMI
CB/NWB	4	27.982/28.000	31.200/31.218	18.150	1.594		AL-LF	03-3981	<b>N151/6</b> STD
CB/NWB	8	27.982/28.000	31.200/31.218	18.150	1.594		AL-LF	03-3982	

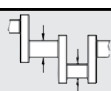
**1172**  **86.00 Petrol** 

**128 A1.000** 4 Cyl. 9:1 1290cc **44kW (60)PS** **TD889 506**

**128 AC.000** 4 Cyl. 9:1 1290cc **55kW (75)PS** **TD890 506**

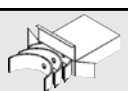

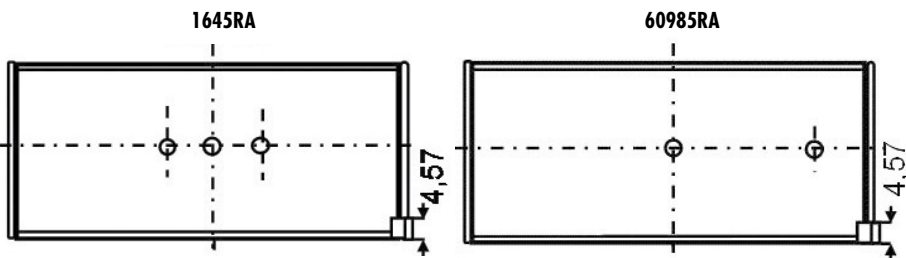

									
BE/PL	4	45.508/45.528	48.629/48.646	19.200	1.547	0.020/0.069	AL-LF	1645RA	<b>01-4127/4</b> STD 0.25 0.50
BE/PL	4	45.508/45.528	48.629/48.646	19.200	1.538	0.025/0.087	AL-LF	60985RA	<b>01-4171/4</b> STD







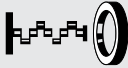
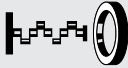



MB/HL 1,2,4,5	4	50.785/50.805	54.507/54.520	20.250	1.831	0.040/0.098	AL-LF	60986RA	<b>H1028/5</b> STD 0.25
MB/HL 3	1	50.785/50.805	54.507/54.520	22.750	1.831	0.040/0.098	AL-LF	60987RA	
TW/A	2	56.610/56.864	69.596/69.850		2.362		AL-LF	60987AFA	<b>A198/2</b> STD .005
SE/PB	1	21.539/21.641	23.939/23.972	25.100			BS	62039Y	<b>55-4288</b> SEMI

# FIAT GROUP

...Continued

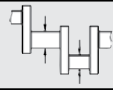
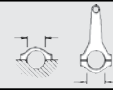

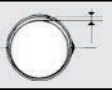
<b>1172</b>	 <b>86.00</b>	<b>Petrol</b>
		
	<b>JH494</b>	<b>NA5051</b>  40.00x56.00x7.00mm, FPM
		
	<b>JH494</b>	

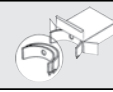
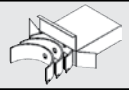

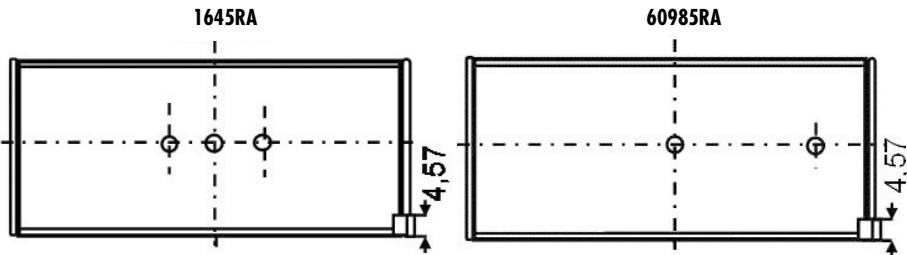

<b>1173</b>	 <b>86.00</b>	<b>Petrol</b>			
<b>128 AR.000</b>	4 Cyl.	9:1	1290cc	<b>50kW (68)PS</b>	<b>TD21448</b>
<b>128 AS.000</b>	4 Cyl.	9.2:1	1290cc	<b>54-55kW (73-75)PS</b>	<b>TD995 507</b>

									
BE/PL	4	45.508/45.528	48.629/48.646	19.200	1.547	0.020/0.069	AL-LF	1645RA	<b>01-4127/4</b> STD 0.25 0.50
BE/PL	4	45.508/45.528	48.629/48.646	19.200	1.538	0.025/0.087	AL-LF	60985RA	<b>01-4171/4</b> STD





MB/HL 1,2,4,5	4	50.785/50.805	54.507/54.520	20.250	1.831	0.040/0.098	AL-LF	60986RA	<b>H1028/5</b> STD 0.25
MB/HL 3	1	50.785/50.805	54.507/54.520	22.750	1.831	0.040/0.098	AL-LF	60987RA	
TW/A	2	56.610/56.864	69.596/69.850		2.362		AL-LF	60987AFA	<b>A198/2</b> STD .005
SE/PB	1	21.539/21.641	23.939/23.972	25.100			BS	62039Y	<b>55-4288</b> SEMI









<b>1174</b>	 <b>86.00</b>	<b>Petrol</b>			
<b>194 A1.000</b>	4 Cyl.	10:1	2198cc	<b>108kW (147)PS</b>	<b>TD18447 517</b>
<b>939 A5.000</b>	4 Cyl.		2198cc	<b>136kW (185)PS</b>	<b>TD18913 518</b>
<b>939 A6.000</b>	4 Cyl.	11.3:1	1859cc	<b>118kW (160)PS</b>	<b>TD18475 508</b>

		
	<b>HR397</b>	<b>NA5108</b>  42.00x55.00x7.00mm, FPM/ACM <b>NB806</b>  90.00x104.00x11.00mm, FPM

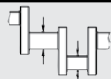

**1175**  **86.00** **Petrol** 

RFL 4 Cyl. 9.5:1 1998cc **81kW (110)PS** TD16405 **509**

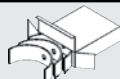

									
BE/PL	4	49.984/50.000	53.695/53.708	21.950	1.834	0.027/0.081	AL-LF	4150RA	<b>01-4149/4</b> STD 0.30
BE/PL	4	49.984/50.000	53.695/53.708	20.250	1.837	0.021/0.075	AL	4305RA	<b>01-4298/4</b> STD 0.30

4150RA

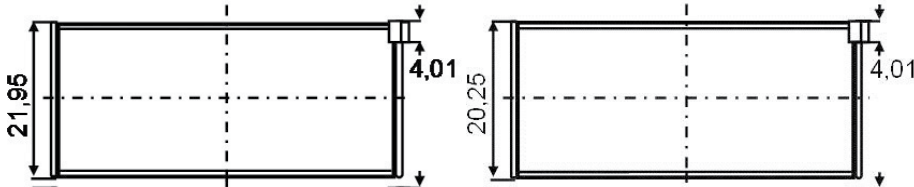
4305RA

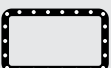

MB/HL 1-5	5	59.981/60.000	63.731/63.750	20.290	1.845	0.040/0.100	AL-LF	66726RA	<b>H1057/5</b> STD 0.30 0.50
TW/A	4	67.050/67.300	83.050/83.300		1.880		AL-LF	4141AF	<b>A188/4</b> STD
TW/A	2	56.800/57.050	73.300/73.550		2.400		AL-LF	4131AF	<b>A241/2</b> STD

		
<b>ES820</b>	<b>JJ283</b> [20]	<b>NA5191</b> 42.00x62.00x7.00mm, PTFE <b>NA5192</b> 90.00x110.00x7.00mm, PTFE
		



JJ283

[20] Oil Pan Material: Steel

[20] Matériel pour carter d'huile: acier







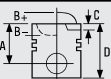
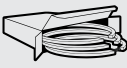

[20] Materiale coppa olio: Acciaio

[20] Material cárter: Acero

**1176**  **86.00** **Petrol** 

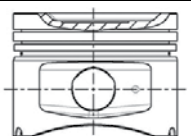
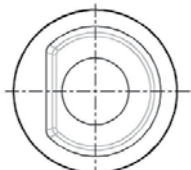
RFU (XU10J2C) 4 Cyl. 9.5:1 1998cc **89kW (121)PS** TD4349 **510**

RFW 4 Cyl. 9.5:1 1998cc **80kW (109)PS** TD6808 **513**

			
<b>87-154600-00</b> <b>87-154608-00</b>	STD 0.60mm	<b>08-154600-00</b> <b>08-154605-00</b> <b>08-154608-00</b>	STD 0.25mm 0.60mm
A 40.00 B- 5.02 D 65.00  22x62	 	1.50  MO P 1.75  P 3.00  CR [15]	

[15] Steel

[15] Acier

[15] Acciaio

[15] Acero

# FIAT GROUP

...Continued

## 1176



86.00

Petrol

BE/PL	4	49.984/50.000	53.695/53.708	21.950	1.834	0.027/0.081	AL-LF	4150RA	<b>01-4149/4</b> STD 0.30
BE/PL	4	49.984/50.000	53.695/53.708	20.250	1.837	0.021/0.075	AL	4305RA	<b>01-4298/4</b> STD 0.30

4150RA

4305RA

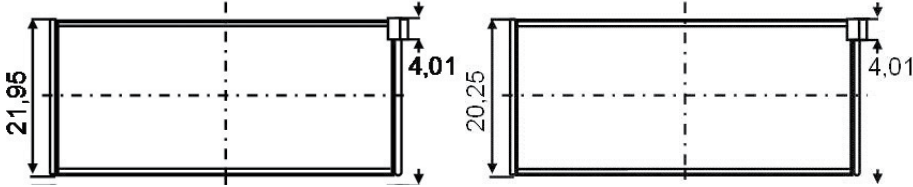

MB/HL 1-5	5	59.981/60.000	63.731/63.750	20.290	1.845	0.040/0.100	AL-LF	66726RA	<b>H1057/5</b> STD 0.30 0.50
TW/A	4	67.050/67.300	83.050/83.300		1.880		AL-LF	4141AF	<b>A188/4</b> STD
TW/A	2	56.800/57.050	73.300/73.550		2.400		AL-LF	4131AF	<b>A241/2</b> STD

<b>ES820</b>	<b>JJ283</b> [20] (Steel) = <b>PA349</b> 22.00x16.00x2.000mm = <b>PB907</b> 14.00x21.00x2.000mm  <b>JJ283</b>	<b>NA5191</b> 42.00x62.00x7.00mm, PTFE <b>NA5192</b> 90.00x110.00x7.00mm, PTFE

[20] Oil Pan Material: Steel

[20] Matériel pour carter d'huile: acier

[20] Materiale coppa olio: Acciaio

[20] Material cárter: Acero

## 1177



86.00

Petrol



RFV (XU10J4R) 4 Cyl. 10.4:1 1998cc 97kW (132)PS TD26959 511

	<b>08-154600-00</b> STD <b>08-154605-00</b> 0.25mm <b>08-154608-00</b> 0.60mm  1.50  MO P 1.75  P 3.00  CR [15]		

[15] Steel









[15] Acier

[15] Acciaio

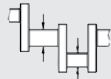
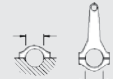
[15] Acero

...Continued



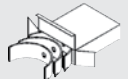





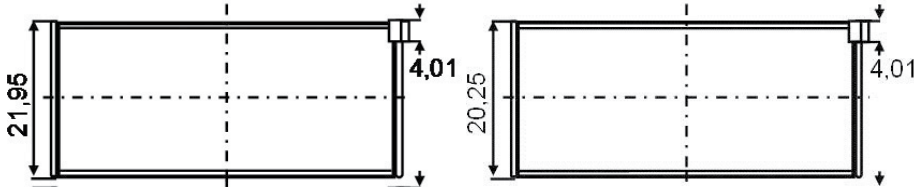



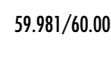
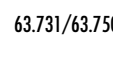

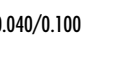





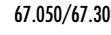
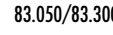



**1177**  **86.00** **Petrol**

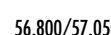

									
BE/PL	4	49.984/50.000	53.695/53.708	21.950	1.834	0.027/0.081	AL-LF	4150RA	01-4149/4 STD 0.30
BE/PL	4	49.984/50.000	53.695/53.708	20.250	1.837	0.021/0.075	AL	4305RA	01-4298/4 STD 0.30



4150RA

4305RA



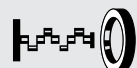



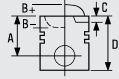
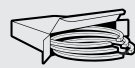

									
MB/HL 1-5	5	59.981/60.000	63.731/63.750	20.290	1.845	0.040/0.100	AL-LF	66726RA	H1057/5 STD 0.30 0.50
									
TW/A	4	67.050/67.300	83.050/83.300	1.880	1.880	AL-LF	4141AF	A188/4 STD	
									
TW/A	2	56.800/57.050	73.300/73.550	2.400	2.400	AL-LF	4131AF	A241/2 STD	

		
EV140	HR397	

**1178**  **86.00** **Petrol** 

RFV 4 Cyl. 10.4:1 1998cc 97-100kW (132-136)PS TD18824 **512**

			
	<p>08-154600-00 STD</p> <p>08-154605-00 0.25mm</p> <p>08-154608-00 0.60mm</p> <p>1.50  MO P</p> <p>1.75  P</p> <p>3.00  CR [15]</p>		

[15] Steel

[15] Acier











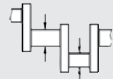
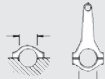

[15] Acciaio

[15] Acero

# FIAT GROUP

...Continued

**1178**  **86.00** **Petrol**



												
BE/PL	4	49.984/50.000	53.695/53.708	21.950	1.834	0.027/0.081	AL-LF	4150RA	<b>01-4149/4</b> STD 0.30			
BE/PL	4	49.984/50.000	53.695/53.708	20.250	1.837	0.021/0.075	AL	4305RA	<b>01-4298/4</b> STD 0.30			

4150RA

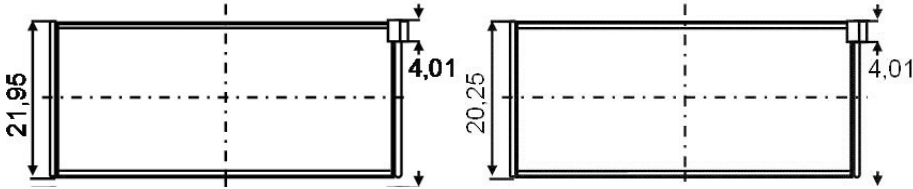
4305RA







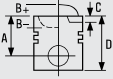
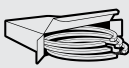

MB/HL 1-5	5	59.981/60.000	63.731/63.750	20.290	1.845	0.040/0.100	AL-LF	66726RA	<b>H1057/5</b> STD 0.30 0.50
TW/A	4	67.050/67.300	83.050/83.300		1.880		AL-LF	4141AF	<b>A188/4</b> STD
TW/A	2	56.800/57.050	73.300/73.550		2.400		AL-LF	4131AF	<b>A241/2</b> STD

		
EV140	HR397	NA5191 42.00x62.00x7.00mm, PTFE









**1179**  **86.00** **Petrol** 

RGX (XU10J2CTE) 4 Cyl. 8.5:1 1998cc 108kW (147)PS Turbo Intercooled TD4355 514

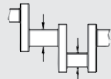
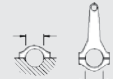
			
	<p><b>08-154600-00</b> STD</p> <p><b>08-154605-00</b> 0.25mm</p> <p><b>08-154608-00</b> 0.60mm</p> <p>1.50  MO P</p> <p>1.75  P</p> <p>3.00  CR [15]</p>		
[15] Steel	[15] Acier	[15] Acciaio	[15] Acero

...Continued

**1179**  **86.00** **Petrol**

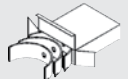

									
BE/PL	4	49.984/50.000	53.695/53.708	21.950	1.834	0.027/0.081	AL-LF	4150RA	<b>01-4149/4</b> STD 0.30
BE/PL	4	49.984/50.000	53.695/53.708	20.250	1.837	0.021/0.075	AL	4305RA	<b>01-4298/4</b> STD 0.30

4150RA

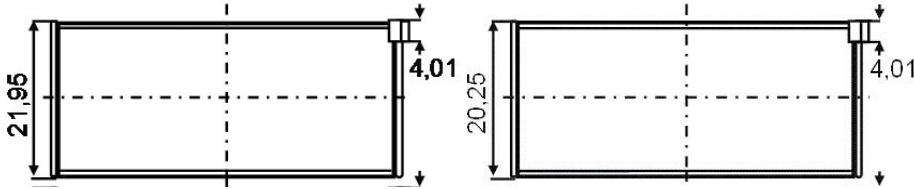
4305RA





MB/HL 1-5	5	59.981/60.000	63.731/63.750	20.290	1.845	0.040/0.100	AL-LF	66726RA	<b>H1057/5</b> STD 0.30 0.50
TW/A	4	67.050/67.300	83.050/83.300		1.880		AL-LF	4141AF	<b>A188/4</b> STD
TW/A	2	56.800/57.050	73.300/73.550		2.400		AL-LF	4131AF	<b>A241/2</b> STD

		
---	---	---

ES820

JJ283 [20]

NA5191  42.00x62.00x7.00mm, PTFE  
NA5192  90.00x110.00x7.00mm, PTFE



JJ283

[20] Oil Pan Material: Steel







[20] Matériel pour carter d'huile: acier

[20] Materiale coppa olio: Acciaio

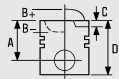
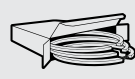
[20] Material cárter: Acero

**1180**  **86.00** **Petrol** 

<b>RGX (XU10J2TE)</b>	<b>4 Cyl.</b>	<b>8.8:1</b>	<b>1998cc</b>	<b>108kW (147)PS</b>	<b>Turbocharged</b>	<b>TD26958</b>	<b>515</b>
-----------------------	---------------	--------------	---------------	----------------------	---------------------	----------------	------------









			
	<p><b>08-154600-00</b> STD</p> <p><b>08-154605-00</b> 0.25mm</p> <p><b>08-154608-00</b> 0.60mm</p> <p>1.50  MO P</p> <p>1.75  P</p> <p>3.00  CR [15]</p>		

[15] Steel

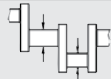
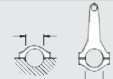
[15] Acier

[15] Acciaio

[15] Acero

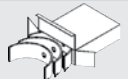
									
BE/PL	4	49.984/50.000	53.695/53.708	21.950	1.843	0.020/0.064	BS	4255CP	<b>71-4279/4</b> STD 0.30
MB/HL 1-5	5	59.981/60.000	63.731/63.750	20.290	1.845	0.040/0.100	AL-LF	66726RA	<b>H1057/5</b> STD 0.30 0.50
TW/A	4	67.050/67.300	83.050/83.300		1.880		AL-LF	4141AF	<b>A188/4</b> STD

## 1181

86.00

**Diesel**



4HU Euro 4 (D4)

4 Cyl.

17.5:1

2198cc

88kW (120)PS

Turbo Intercooled

TD25655

<p><b>87-427700-10</b> STD <b>87-427707-10</b> 0.50mm</p> <p><b>A</b> 43.42 <b>B-</b> 15.85 <b>BØ</b> 46.90 <b>D</b> 69.82  30x67</p> <p><b>KK RT TP</b></p>	<p><b>8648B105</b></p>	<p><b>08-427700-00</b> STD <b>08-427707-00</b> 0.50mm</p> <p>2.00  CK P 2.00  P 2.00  NT [15]</p>	<p><b>14-021120-00 D</b> <b>B</b> 89.00 <b>C</b> 156.00 <b>D</b> 90.90 <b>E</b> 5.00</p>

[15] Steel      [15] Acier      [15] Acciaio      [15] Acero

BE/PL	4	52.980/53.000	55.996/56.016	24.450	1.487	0.026/0.084	BS	71-4066	<b>71-4066/4</b> STD 0.25 0.50 <b>H1018/5</b> STD 0.25 0.50
MB/HL	4	64.940	69.520	23.280	2.250		AL-LF	02-4067	
MB/HL	3	64.940	69.520	24.080	2.250		AL-LF	02-4068	
MB/HL	2	69.940	74.520	19.580	2.250		AL-LF	02-4069	
MB/HL	1	64.940	69.520	30.150	2.250		AL-LF	02-4070H	

## 1182

86.00

**Diesel**



4HV Euro 4 (D4)

4 Cyl.

17.5:1

2198cc

74kW (101)PS

Turbo Intercooled













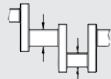
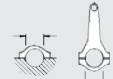

TD20266

516

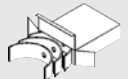







<p><b>87-427700-30</b> STD</p> <p><b>A</b> 43.42 <b>B-</b> 15.85 <b>BØ</b> 46.90 <b>D</b> 69.82  30x67</p> <p><b>RT TP</b></p>	<p><b>08650A105</b></p>	<p><b>08-427700-00</b> STD <b>08-427707-00</b> 0.50mm</p> <p>2.00  CK P 2.00  P 2.00  NT [15]</p>	<p><b>14-021120-00 D</b> <b>B</b> 89.00 <b>C</b> 156.00 <b>D</b> 90.90 <b>E</b> 5.00</p>

[15] Steel      [15] Acier      [15] Acciaio      [15] Acero

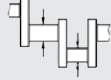
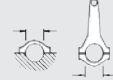
...Continued

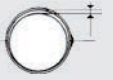
<b>1182</b>		 <b>86.00</b>	<b>Diesel</b>							
										
BE/PL	4	52.980/53.000	55.996/56.016	24.450	1.487	0.026/0.084	BS	71-4066	<b>71-4066/4</b> STD 0.25 0.50	
MB/HL	4	64.940	69.520	23.280	2.250		AL-LF	02-4067	<b>H1018/5</b> STD 0.25 0.50	
MB/HL	3	64.940	69.520	24.080	2.250		AL-LF	02-4068		
MB/HL	2	69.940	74.520	19.580	2.250		AL-LF	02-4069		
MB/HL	1	64.940	69.520	30.150	2.250		AL-LF	02-4070H		
										
			HR397				<b>NA5031</b>  50.00x86.50x13.70mm, PTFE <b>NA5030</b>  106.00x196.00x15.20mm, FPM			

<b>1183</b>		 <b>86.40</b>	<b>Petrol</b>						
<b>128 A3.000</b>	4 Cyl.	9.1:1	1301cc	<b>55kW (75)PS</b>			<b>TD21446</b>		
<b>138 A.000</b>	4 Cyl.	9.1:1	1302cc	<b>37-48kW (50-65)PS</b>			<b>TD18855</b> <b>525</b>		
<b>149 A7.003</b>	4 Cyl.	9.2:1	1301cc	<b>48-50kW (65-68)PS</b>			<b>TD23357</b>		

									
BE/PL	4	45.508/45.528	48.629/48.646	19.200	1.547	0.020/0.069	AL-LF	1645RA	<b>01-4127/4</b> STD 0.25 0.50
BE/PL	4	45.508/45.528	48.629/48.646	19.200	1.538	0.025/0.087	AL-LF	60985RA	<b>01-4171/4</b> STD

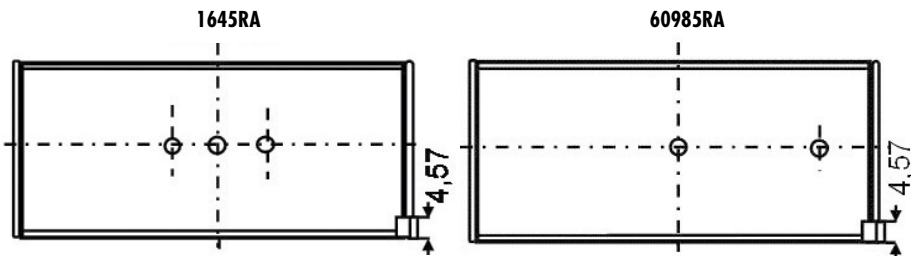

MB/HL 1,2,4,5	4	50.785/50.805	54.507/54.520	20.250	1.831	0.040/0.098	AL-LF	60986RA	<b>H1028/5</b> STD 0.25
MB/HL 3	1	50.785/50.805	54.507/54.520	22.750	1.831	0.040/0.098	AL-LF	60987RA	
TW/A	2	56.610/56.864	69.596/69.850		2.362		AL-LF	60987AFA	<b>A198/2</b> STD .005
SE/PB	1	21.539/21.641	23.939/23.972	25.100			BS	62039Y	<b>55-4288</b> SEMI







## 1184

 **86.40**

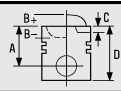
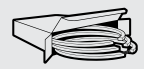





**Petrol**

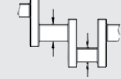
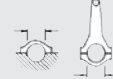

<b>138 A1.000</b>	4 Cyl.	9:1	1301cc	<b>48kW (65)PS</b>	<b>TD4368</b>	<b>519</b>
<b>138 A3.000</b>	4 Cyl.	9:1	1301cc	<b>55kW (75)PS</b>	<b>TD4362</b>	<b>520</b>

				<b>08-209700-00</b> STD <b>08-209706-00</b> 0.40mm <b>08-209708-00</b> 0.60mm
				1.50  CR P 2.00  P 3.95  CR [15]

[15] Steel      [15] Acier      [15] Acciaio      [15] Acero

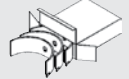

									
BE/PL	4	45.508/45.528	48.629/48.646	19.200	1.547	0.020/0.069	AL-LF	1645RA	<b>01-4127/4</b> STD 0.25 0.50
BE/PL	4	45.508/45.528	48.629/48.646	19.200	1.538	0.025/0.087	AL-LF	60985RA	<b>01-4171/4</b> STD

1645RA

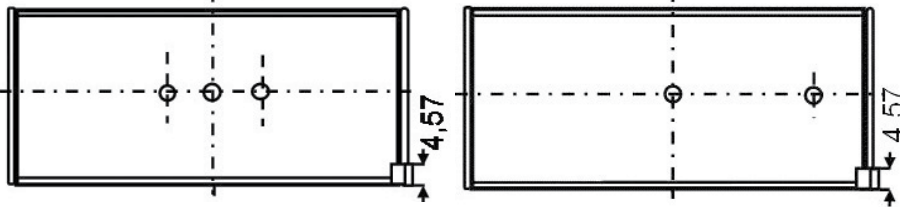

60985RA



MB/HL 1,2,4,5	4	50.785/50.805	54.507/54.520	20.250	1.831	0.040/0.098	AL-LF	60986RA	<b>H1028/5</b> STD 0.25
MB/HL 3	1	50.785/50.805	54.507/54.520	22.750	1.831	0.040/0.098	AL-LF	60987RA	
TW/A	2	56.610/56.864	69.596/69.850		2.362		AL-LF	60987AFA	<b>A198/2</b> STD .005
SE/PB	1	21.539/21.641	23.939/23.972	25.100			BS	62039Y	<b>55-4288</b> SEMI

		
---	---	---



JH494









**NB818**  40.00x56.00x7.00mm, ACM  
**NA5049**  64.00x80.00x8.00mm, ACM

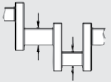
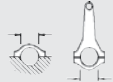

JH494



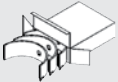

**1185**  **86.40** **Petrol**   
**146 A5.000** 4 Cyl. 9.3:1 1301cc **49kW (67)PS** **TD4376** **521**

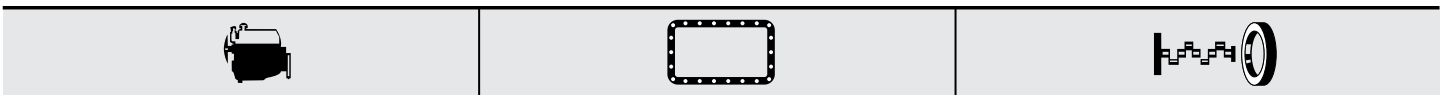











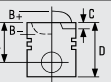
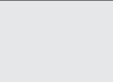

									
BE/PL	4	43.988/44.008	47.130/47.142	18.500	1.546	0.030/0.087	AL-LF	68090RA	<b>01-4207/4</b> STD 0.25 0.50
MB/HL 1,2,4,5	4	48.189/48.209	51.921/51.934	17.650	1.841	0.030/0.088	AL-LF	68091RA	<b>H1069/5</b> STD 0.25 0.50
MB/HL 3	1	48.189/48.209	51.921/51.934	25.250	1.841	0.030/0.088	AL-LF	68092RA	
TW/A	2	54.224/54.478	66.996/67.520		2.362		AL-LF	68092AF	<b>A221/2</b> STD
SE/PB	1	21.539/21.641	23.939/23.972	25.100			BS	62039Y	<b>55-4288</b> SEMI



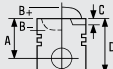





**JJ078**  
  
**JJ078**

**NB818**  40.00x56.00x7.00mm, ACM

**1186**  **86.40** **Petrol**   
**149 A3.000** 4 Cyl. 9.1:1 1301cc **48kW (65)PS** **TD958** **522**

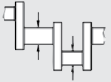
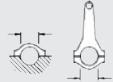

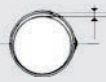

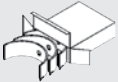

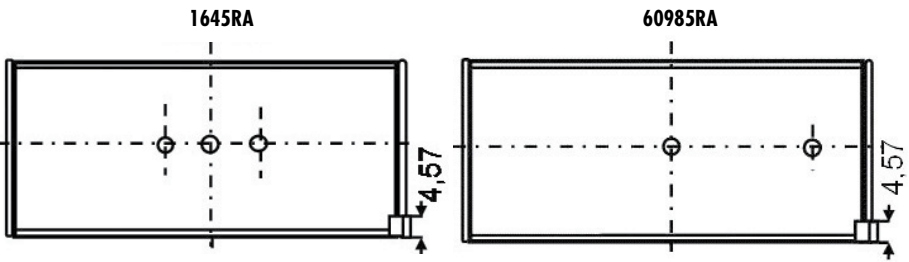
									
									
			<b>08-209700-00</b> STD <b>08-209706-00</b> 0.40mm <b>08-209708-00</b> 0.60mm						
			1.50  CR P 2.00  P 3.95  CR [15]						



[15] Steel      [15] Acier      [15] Acciaio      [15] Acero

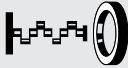





									
BE/PL	4	45.508/45.528	48.629/48.646	19.200	1.547	0.020/0.069	AL-LF	1645RA	<b>01-4127/4</b> STD 0.25 0.50
BE/PL	4	45.508/45.528	48.629/48.646	19.200	1.538	0.025/0.087	AL-LF	60985RA	<b>01-4171/4</b> STD



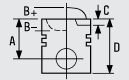
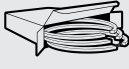





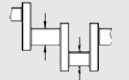

MB/HL 1,2,4,5	4	50.785/50.805	54.507/54.520	20.250	1.831	0.040/0.098	AL-LF	60986RA	<b>H1028/5</b> STD 0.25
MB/HL 3	1	50.785/50.805	54.507/54.520	22.750	1.831	0.040/0.098	AL-LF	60987RA	
TW/A	2	56.610/56.864	69.596/69.850		2.362		AL-LF	60987AFA	<b>A198/2</b> STD .005
SE/PB	1	21.539/21.641	23.939/23.972	25.100			BS	62039Y	<b>55-4288</b> SEMI

<b>1186</b>	 <b>86.40</b>	<b>Petrol</b>
		
	<b>JJ453</b> → Eng.9508753  <b>JJ453</b>	<b>NB818</b>  40.00x56.00x7.00mm, ACM <b>NA5049</b>  64.00x80.00x8.00mm, ACM

<b>1187</b>	 <b>86.40</b>	<b>Petrol</b>				
<b>831 A2.000</b>	4 Cyl.	9.5:1	130lcc	<b>55-58kW (75-79)PS</b>	<b>TD4605</b>	<b>523</b>
<b>831 B.000</b>	4 Cyl.	9.5:1	130lcc	<b>55kW (75)PS</b>	<b>TD1809</b>	<b>524</b>

			
	<b>08-209700-00</b> STD <b>08-209706-00</b> 0.40mm <b>08-209708-00</b> 0.60mm  1.50  CR P 2.00  P 3.95  CR [15]		
[15] Steel	[15] Acier	[15] Acciaio	[15] Acero

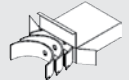
									
BE/PL	4	45.508/45.528	48.629/48.646	19.200	1.547	0.020/0.069	AL-LF	1645RA	<b>01-4127/4</b> STD 0.25 0.50
BE/PL	4	45.508/45.528	48.629/48.646	19.200	1.538	0.025/0.087	AL-LF	60985RA	<b>01-4171/4</b> STD

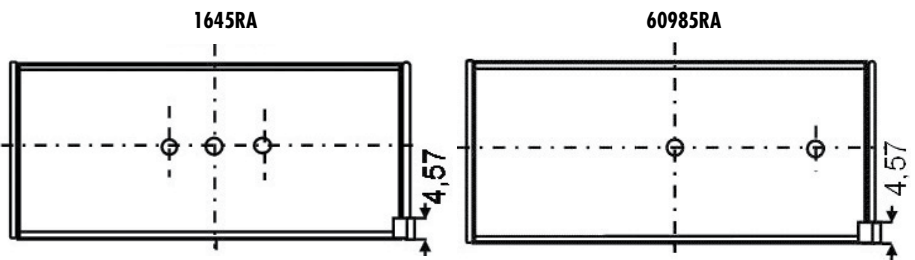

MB/HL 1,2,4,5	4	50.785/50.805	54.507/54.520	20.250	1.831	0.040/0.098	AL-LF	60986RA	<b>H1028/5</b> STD 0.25
MB/HL 3	1	50.785/50.805	54.507/54.520	22.750	1.831	0.040/0.098	AL-LF	60987RA	
TW/A	2	56.610/56.864	69.596/69.850		2.362		AL-LF	60987AFA	<b>A198/2</b> STD .005
SE/PB	1	21.539/21.641	23.939/23.972	25.100			BS	62039Y	<b>55-4288</b> SEMI

## 1188

### 86.40

### Petrol



<b>138 B2.000</b>	4 Cyl.	9.1:1	1302cc	<b>50-51kW (68-69)PS</b>	<b>TD4363</b>	<b>526</b>
<b>149 A7.000</b>	4 Cyl.	9.6:1	1302cc	<b>48kW (65)PS</b>	<b>TD4382</b>	<b>526</b>

<p>1.50  CR P</p> <p>2.00  P</p> <p>3.95  CR [15]</p>			

[15] Steel                      [15] Acier                      [15] Acciaio                      [15] Acero

BE/PL	4	45.508/45.528	48.629/48.646	19.200	1.547	0.020/0.069	AL-LF	1645RA	<b>01-4127/4</b> STD 0.25 0.50	
BE/PL	4	45.508/45.528	48.629/48.646	19.200	1.538	0.025/0.087	AL-LF	60985RA	<b>01-4171/4</b> STD	

**1645RA**

**60985RA**

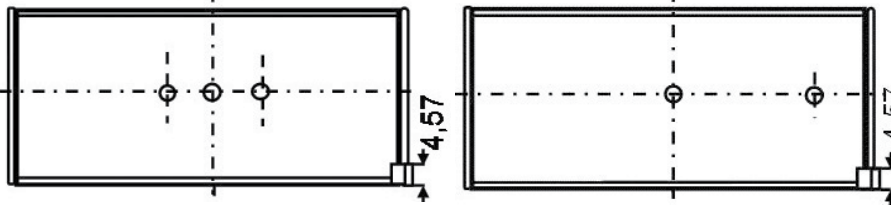

MB/HL 1,2,4,5	4	50.785/50.805	54.507/54.520	20.250	1.831	0.040/0.098	AL-LF	60986RA	<b>H1028/5</b> STD 0.25
MB/HL 3	1	50.785/50.805	54.507/54.520	22.750	1.831	0.040/0.098	AL-LF	60987RA	
TW/A	2	56.610/56.864	69.596/69.850		2.362		AL-LF	60987AFA	<b>A198/2</b> STD .005
SE/PB	1	21.539/21.641	23.939/23.972	25.100			BS	62039Y	<b>55-4288</b> SEMI

--	--	--

JJ453

**NB818** 40.00x56.00x7.00mm, ACM  
**NA5049** 64.00x80.00x8.00mm, ACM

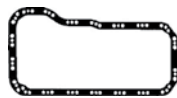

JJ453

# FIAT GROUP











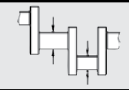

## 1189

 **86.40**

**Petrol**



149 A7.046      4 Cyl.      9.2:1      1302cc      **50kW (68)PS**      **TD23864**

											
BE/PL	4	43.988/44.008	47.130/47.142	18.500	1.546	0.030/0.087	AL-LF	68090RA	<b>01-4207/4</b> STD 0.25 0.50		
MB/HL 1,2,4,5	4	48.189/48.209	51.921/51.934	17.650	1.841	0.030/0.088	AL-LF	68091RA	<b>H1069/5</b> STD 0.25 0.50		
MB/HL 3	1	48.189/48.209	51.921/51.934	25.250	1.841	0.030/0.088	AL-LF	68092RA			
TW/A	2	54.224/54.478	66.996/67.520		2.362		AL-LF	68092AF	<b>A221/2</b> STD		
SE/PB	1	21.539/21.641	23.939/23.972	25.100			BS	62039Y	<b>55-4288</b> SEMI		

## 1190

 **86.40**

**Petrol**













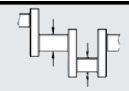

128 A5.000      4 Cyl.      9.1:1      1499cc      **55-63kW (75-86)PS**      **TD21447**

138 BS.031      4 Cyl.           1499cc      **56kW (76)PS**      **TD918**

138 C.048      4 Cyl.           1498cc      **55-57kW (75-78)PS**      **TD4367**

138 C2.048      4 Cyl.      9:1      1498cc      **55kW (75)PS**      **TD5424**      **531**

149 A5.046      4 Cyl.      9.2:1      1498cc      **58-63kW (79-86)PS**      **TD23863**

											
BE/PL	4	45.508/45.528	48.629/48.646	19.200	1.547	0.020/0.069	AL-LF	1645RA	<b>01-4127/4</b> STD 0.25 0.50		
MB/HL 1,2,4,5	4	52.982/53.000	56.705/56.718	20.750	1.843	0.019/0.075	AL-LF	4351RA	<b>H1096/5</b> STD 0.25 0.50		
MB/HL 3	1	52.982/53.000	56.705/56.718	20.750	1.838	0.029/0.085	AL-LF	4352RA			
TW/A	2	56.610/56.864	69.596/69.850		2.362		AL-LF	60987AFA	<b>A198/2</b> STD .005		
SE/PB	1	21.539/21.641	23.939/23.972	25.100			BS	62039Y	<b>55-4288</b> SEMI		

## 1191

 **86.40**







**Petrol**

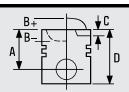
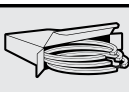

138 A2.000      4 Cyl.      9:1      1498cc      **55-57kW (75-78)PS**      **TD916**      **527**

138 A4.000      4 Cyl.      9.2:1      1498cc      **63kW (86)PS**      **TD4357**      **528**

138 B3.000      4 Cyl.      9.2:1      1498cc      **55-61kW (75-83)PS**      **TD4365**      **529**

			
	<b>08-209700-00</b> STD <b>08-209706-00</b> 0.40mm <b>08-209708-00</b> 0.60mm  1.50  CR P 2.00  P 3.95  CR [15]		









[15] Steel



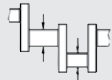
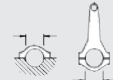



[15] Acier

[15] Acciaio





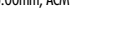

[15] Acero

...Continued

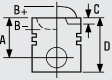







<b>1191</b>		 <b>86.40</b>		<b>Petrol</b>					
									
BE/PL	4	45.508/45.528	48.629/48.646	19.200	1.547	0.020/0.069	AL-LF	1645RA	<b>01-4127/4</b> STD 0.25 0.50
MB/HL 1,2,4,5	4	52.982/53.000	56.705/56.718	20.750	1.843	0.019/0.075	AL-LF	4351RA	<b>H1096/5</b> STD 0.25 0.50
MB/HL 3	1	52.982/53.000	56.705/56.718	20.750	1.838	0.029/0.085	AL-LF	4352RA	
TW/A	2	56.610/56.864	69.596/69.850		2.362		AL-LF	60987AFA	<b>A198/2</b> STD .005
SE/PB	1	21.539/21.641	23.939/23.972	25.100			BS	62039Y	<b>55-4288</b> SEMI

		
	<b>JH494</b>	<b>NB818</b>  40.00x56.00x7.00mm, ACM <b>NA5049</b>  64.00x80.00x8.00mm, ACM
		
	<b>JH494</b>	

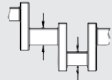
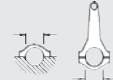
<b>1192</b>		 <b>86.40</b>		<b>Petrol</b>			
<b>138 AS.000</b>	4 Cyl.	9:1	1499cc	<b>63kW (85)PS</b>		<b>TD4359</b>	<b>537</b>
<b>831 B1.000</b>	4 Cyl.	9.2:1	1498cc	<b>59-63kW (80-86)PS</b>		<b>TD1811</b>	<b>535</b>
<b>831 B1.048</b>	4 Cyl.		1498cc	<b>55kW (75)PS</b>		<b>TD1810</b>	<b>536</b>

			
	<b>08-209700-00</b> STD <b>08-209706-00</b> 0.40mm <b>08-209708-00</b> 0.60mm  1.50  CR P 2.00  P 3.95  CR [15]		

[15] Steel      [15] Acier      [15] Acciaio      [15] Acero

									
BE/PL	4	45.508/45.528	48.629/48.646	19.200	1.547	0.020/0.069	AL-LF	1645RA	<b>01-4127/4</b> STD 0.25 0.50
MB/HL 1,2,4,5	4	52.982/53.000	56.705/56.718	20.750	1.843	0.019/0.075	AL-LF	4351RA	<b>H1096/5</b> STD 0.25 0.50
MB/HL 3	1	52.982/53.000	56.705/56.718	20.750	1.838	0.029/0.085	AL-LF	4352RA	
TW/A	2	56.610/56.864	69.596/69.850		2.362		AL-LF	60987AFA	<b>A198/2</b> STD .005
SE/PB	1	21.539/21.641	23.939/23.972	25.100			BS	62039Y	<b>55-4288</b> SEMI

# FIAT GROUP

## 1193

86.40

Petrol



138 B3.048

4 Cyl.

9:1

1498cc

55-57kW (75-78)PS

TD4364

530

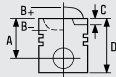

**08-209700-00** STD  
**08-209706-00** 0.40mm  
**08-209708-00** 0.60mm

1.50 CR P  
 2.00 P  
 3.95 CR [15]

[15] Steel

[15] Acier

[15] Acciaio

[15] Acero

BE/PL	4	45.508/45.528	48.629/48.646	19.200	1.547	0.020/0.069	AL-LF	1645RA	<b>01-4127/4</b> STD 0.25 0.50
MB/HL 1,2,4,5	4	52.982/53.000	56.705/56.718	20.750	1.843	0.019/0.075	AL-LF	4351RA	<b>H1096/5</b> STD 0.25 0.50
MB/HL 3	1	52.982/53.000	56.705/56.718	20.750	1.838	0.029/0.085	AL-LF	4352RA	
TW/A	2	56.610/56.864	69.596/69.850		2.362		AL-LF	60987AFA	<b>A198/2</b> STD .005
SE/PB	1	21.539/21.641	23.939/23.972	25.100			BS	62039Y	<b>55-4288</b> SEMI



JJ453

**NB818** 40.00x56.00x7.00mm, ACM  
**NA5049** 64.00x80.00x8.00mm, ACM

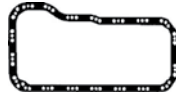

JJ453

## 1194

86.40

Petrol



138 C3.048

4 Cyl.

1498cc

55-57kW (75-78)PS

TD4366

532

149 A5.000

4 Cyl.

9.2:1

1498cc







58kW (79)PS









TD4381



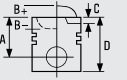
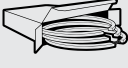





533



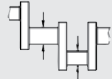
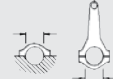







BE/PL	4	45.508/45.528	48.629/48.646	19.200	1.547	0.020/0.069	AL-LF	1645RA	<b>01-4127/4</b> STD 0.25 0.50
MB/HL 1,2,4,5	4	52.982/53.000	56.705/56.718	20.750	1.843	0.019/0.075	AL-LF	4351RA	<b>H1096/5</b> STD 0.25 0.50
MB/HL 3	1	52.982/53.000	56.705/56.718	20.750	1.838	0.029/0.085	AL-LF	4352RA	
TW/A	2	56.610/56.864	69.596/69.850		2.362		AL-LF	60987AFA	<b>A198/2</b> STD .005
SE/PB	1	21.539/21.641	23.939/23.972	25.100			BS	62039Y	<b>55-4288</b> SEMI

...Continued

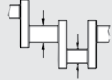
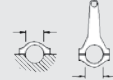
<b>1194</b>	 <b>86.40</b>	<b>Petrol</b>
		
	<b>JH494</b>	<b>NB818</b>  40.00x56.00x7.00mm, ACM <b>NA5049</b>  64.00x80.00x8.00mm, ACM
		
	<b>JH494</b>	



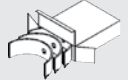

<b>1195</b>	 <b>86.40</b>	<b>Petrol</b>				
<b>831 A1.000</b>	4 Cyl.	9.2:1	1498cc	<b>63kW (86)PS</b>	<b>TD1805</b>	<b>534</b>
						
	<b>08-209700-00</b> STD <b>08-209706-00</b> 0.40mm <b>08-209708-00</b> 0.60mm					
	1.50  CR P 2.00  P 3.95  CR [15]					
[15] Steel	[15] Acier	[15] Acciaio	[15] Acero			



									
BE/PL	4	45.508/45.528	48.629/48.646	19.200	1.547	0.020/0.069	AL-LF	1645RA	<b>01-4127/4</b> STD 0.25 0.50
MB/HL 1,2,4,5	4	50.780/50.800	54.507/54.520	20.250	1.849	0.020/0.067	AL-LF	1646RA	<b>H1075/5</b> STD 0.25 0.50
MB/HL 3	1	50.780/50.800	54.507/54.520	22.750	1.849	0.020/0.067	AL-LF	1647RA	
TW/A	2	56.610/56.864	69.596/69.850		2.362		AL-LF	60987AFA	<b>A198/2</b> STD .005
SE/PB	1	21.539/21.641	23.939/23.972	25.100			BS	62039Y	<b>55-4288</b> SEMI



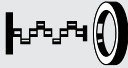

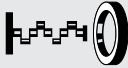
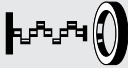





<b>1196</b>	 <b>86.40</b>	<b>Petrol</b>							
<b>138 C2.048</b>	4 Cyl.	9:1	1499cc	<b>55kW (75)PS</b>	<b>TD926</b>	<b>538</b>			
									
BE/PL	4	45.508/45.528	48.629/48.646	19.200	1.547	0.020/0.069	AL-LF	1645RA	<b>01-4127/4</b> STD 0.25 0.50
MB/HL 1,2,4,5	4	52.982/53.000	56.705/56.718	20.750	1.843	0.019/0.075	AL-LF	4351RA	<b>H1096/5</b> STD 0.25 0.50
MB/HL 3	1	52.982/53.000	56.705/56.718	20.750	1.838	0.029/0.085	AL-LF	4352RA	
TW/A	2	56.610/56.864	69.596/69.850		2.362		AL-LF	60987AFA	<b>A198/2</b> STD .005
SE/PB	1	21.539/21.641	23.939/23.972	25.100			BS	62039Y	<b>55-4288</b> SEMI

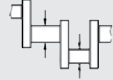



# FIAT GROUP



...Continued



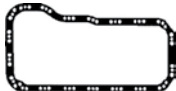





<b>1196</b>	 <b>86.40</b>	<b>Petrol</b>
		
	<b>JH494</b> <b>JJ453</b>  <b>JH494</b>  <b>JJ453</b>	<b>NB818</b>  40.00x56.00x7.00mm, ACM <b>NA5049</b>  64.00x80.00x8.00mm, ACM



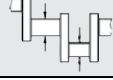

<b>1197</b>	 <b>86.40</b>	<b>Petrol</b>				
<b>149 C1.000</b>	4 Cyl.	9.2:1	1499cc	<b>49-55kW (67-75)PS</b>	<b>TD973</b>	<b>539</b>

									
BE/PL	4	45.508/45.528	48.629/48.646	19.200	1.547	0.020/0.069	AL-LF	1645RA	<b>01-4127/4</b> STD 0.25 0.50
MB/HL 1,2,4,5	4	52.982/53.000	56.705/56.718	20.750	1.843	0.019/0.075	AL-LF	4351RA	<b>H1096/5</b> STD 0.25 0.50
MB/HL 3	1	52.982/53.000	56.705/56.718	20.750	1.838	0.029/0.085	AL-LF	4352RA	
TW/A	2	56.610/56.864	69.596/69.850		2.362		AL-LF	60987AFA	<b>A198/2</b> STD .005
SE/PB	1	21.539/21.641	23.939/23.972	25.100			BS	62039Y	<b>55-4288</b> SEMI

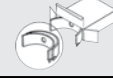
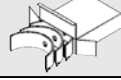
		
	<b>JJ453</b>  <b>JJ453</b>	<b>NB818</b>  40.00x56.00x7.00mm, ACM <b>NA5049</b>  64.00x80.00x8.00mm, ACM

<b>1198</b>	 <b>86.40</b>	<b>Petrol</b>				
<b>146 C6.000</b>	4 Cyl.	19.5:1	1581cc	<b>55kW (75)PS</b>	<b>TD954</b>	<b>540</b>
<b>146 D6.000</b>	4 Cyl.	9.2:1	1581cc	<b>55kW (75)PS</b>	<b>TD959</b>	<b>540</b>

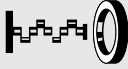
									
BE/PL	4	45.508/45.528	48.629/48.646	19.200	1.547	0.020/0.069	AL-LF	1645RA	<b>01-4127/4</b> STD 0.25 0.50
MB/HL 1,2,4,5	4	50.780/50.800	54.507/54.520	20.250	1.849	0.020/0.067	AL-LF	1646RA	<b>H1075/5</b> STD 0.25 0.50
MB/HL 3	1	50.780/50.800	54.507/54.520	22.750	1.849	0.020/0.067	AL-LF	1647RA	
TW/A	2	56.610/56.864	69.596/69.850		2.362		AL-LF	60987AFA	<b>A198/2</b> STD .005
SE/PB	1	21.539/21.641	23.939/23.972	25.100			BS	62039Y	<b>55-4288</b> SEMI

		
 <b>ET400</b>		



<b>1199</b>	<b>86.40</b>	<b>Petrol</b>	
<b>159 A3.000</b>	4 Cyl.	9.2:1	1581cc
<b>159 A3.046</b>	4 Cyl.	9.2:1	1581cc
		<b>62-66kW (84-90)PS</b>	<b>TD9787 541</b>
		<b>57-65kW (78-88)PS</b>	<b>TD1006 542</b>

 <b>87-783700-00</b> STD <b>87-783706-00</b> 0.40mm <b>87-783708-00</b> 0.60mm  <b>A</b> 33.30 <b>B-</b> 2.30 <b>D</b> 72.80 22x63	 <b>08-783700-00</b> STD <b>08-783706-00</b> 0.40mm <b>08-783708-00</b> 0.60mm <b>08-783711-00</b> 1.00mm  1.50  CR P 1.75  P 3.00  CR [15]	 	
[15] Steel	[15] Acier	[15] Acciaio	[15] Acero









BE/PL	MB/HL 1,2,4,5	TW/A	SE/PB	0.020/0.069	AL-LF	BS	1645RA	<b>01-4127/4</b> STD 0.25 0.50
4	4	2	1	0.020/0.067	AL-LF		1646RA	<b>H1075/5</b> STD 0.25 0.50
45.508/45.528	50.780/50.800	56.610/56.864	21.539/21.641	0.020/0.067	AL-LF		1647RA	
48.629/48.646	54.507/54.520	69.596/69.850	23.939/23.972				60987AFA	<b>A198/2</b> STD .005
19.200	20.250	22.750	25.100				62039Y	<b>55-4288</b> SEMI
1.547	1.849	1.849						
		2.362						

<b>ET400</b>	<b>JJ453</b>	<b>NA5051</b> 40.00x56.00x7.00mm, FPM <b>NA5049</b> 64.00x80.00x8.00mm, ACM
	<b>JJ453</b>	

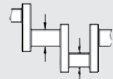
<b>1200</b>	<b>86.40</b>	<b>Petrol</b>	
<b>159 A3.048</b>	4 Cyl.	9.2:1	1581cc
		<b>51-66kW (69-90)PS</b>	<b>TD1007 543</b>

 <b>87-783700-00</b> STD <b>87-783706-00</b> 0.40mm <b>87-783708-00</b> 0.60mm  <b>A</b> 33.30 <b>B-</b> 2.30 <b>D</b> 72.80 22x63	 <b>08-783700-00</b> STD <b>08-783706-00</b> 0.40mm <b>08-783708-00</b> 0.60mm <b>08-783711-00</b> 1.00mm  1.50  CR P 1.75  P 3.00  CR [15]	 	
[15] Steel	[15] Acier	[15] Acciaio	[15] Acero

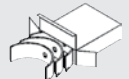

**1200**  **86.40** **Petrol**

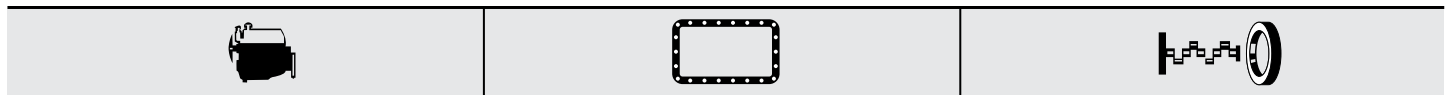
									
BE/PL	4	45.508/45.528	48.629/48.646	19.200	1.547	0.020/0.069	AL-LF	1645RA	<b>01-4127/4</b> STD 0.25 0.50
MB/HL 1,2,4,5	4	50.780/50.800	54.507/54.520	20.250	1.849	0.020/0.067	AL-LF	1646RA	<b>H1075/5</b> STD 0.25 0.50
MB/HL 3	1	50.780/50.800	54.507/54.520	22.750	1.849	0.020/0.067	AL-LF	1647RA	
TW/A	2	56.610/56.864	69.596/69.850		2.362		AL-LF	60987AFA	<b>A198/2</b> STD .005
SE/PB	1	21.539/21.641	23.939/23.972	25.100			BS	62039Y	<b>55-4288</b> SEMI



 ET400

JJ453



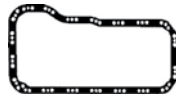





NA5051  40.00x56.00x7.00mm, FPM  
NB818  40.00x56.00x7.00mm, ACM

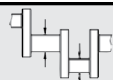

JJ453

**1201**  **86.40** **Petrol** 

159 B9.000      4 Cyl.      1581cc      66kW (90)PS      TD4598      544

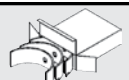
									
BE/PL	4	45.508/45.528	48.629/48.646	19.200	1.547	0.020/0.069	AL-LF	1645RA	<b>01-4127/4</b> STD 0.25 0.50
MB/HL 1,2,4,5	4	50.780/50.800	54.507/54.520	20.250	1.849	0.020/0.067	AL-LF	1646RA	<b>H1075/5</b> STD 0.25 0.50
MB/HL 3	1	50.780/50.800	54.507/54.520	22.750	1.849	0.020/0.067	AL-LF	1647RA	
TW/A	2	56.610/56.864	69.596/69.850		2.362		AL-LF	60987AFA	<b>A198/2</b> STD .005
SE/PB	1	21.539/21.641	23.939/23.972	25.100			BS	62039Y	<b>55-4288</b> SEMI

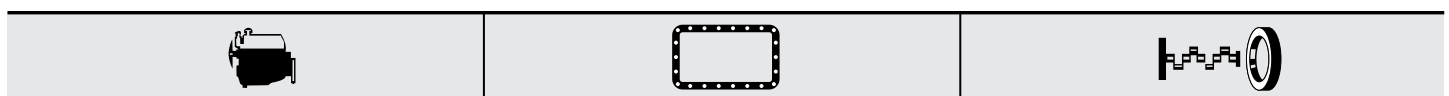

 ET400

JJ453

NF887  [19] 64.00x112.50x20.00mm, FPM





JJ453









[19] Specification: Oil Seal in housing

[19] Caractéristiques: Bague d'étanchéité dans son logement

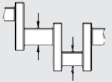
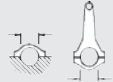
[19] Specifiche: Paraolio in sede

[19] Especificaciones: Retén de aceite de la carcasa

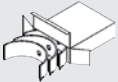

**1202**  **86.40** **Petrol**   
**159 B9.000** 4 Cyl. 1581cc **63-66kW (86-90)PS** **TD965** **545**

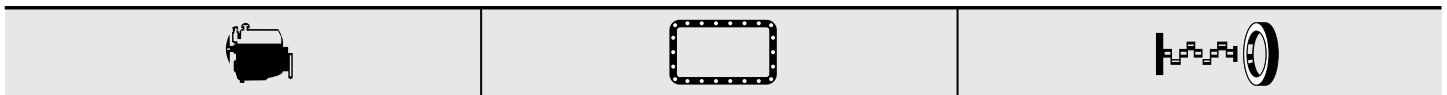
									
BE/PL	4	45.508/45.528	48.629/48.646	19.200	1.547	0.020/0.069	AL-LF	1645RA	<b>01-4127/4</b> STD 0.25 0.50
MB/HL 1,2,4,5	4	50.780/50.800	54.507/54.520	20.250	1.849	0.020/0.067	AL-LF	1646RA	<b>H1075/5</b> STD 0.25 0.50
MB/HL 3	1	50.780/50.800	54.507/54.520	22.750	1.849	0.020/0.067	AL-LF	1647RA	
TW/A	2	56.610/56.864	69.596/69.850		2.362		AL-LF	60987AFA	<b>A198/2</b> STD .005
SE/PB	1	21.539/21.641	23.939/23.972	25.100			BS	62039Y	<b>55-4288</b> SEMI





 ET400



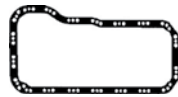







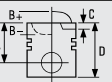

JJ453

NA5051  40.00x56.00x7.00mm, FPM  
 NA5049  64.00x80.00x8.00mm, ACM

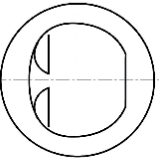
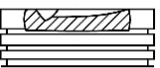

JJ453

**1203**  **86.40** **Petrol**   
**160 A2.000** 4 Cyl. 9.2:1 1581cc **58-62kW (79-84)PS** **TD1019** **546**









									
<b>87-783700-00</b> <b>87-783706-00</b> <b>87-783708-00</b>	STD 0.40mm 0.60mm			<b>08-783700-00</b> <b>08-783706-00</b> <b>08-783708-00</b> <b>08-783711-00</b>	STD 0.40mm 0.60mm 1.00mm		1.50 CR P 1.75 P 3.00 CR [15]		
A 33.30 B- 2.30 D 72.80  22x63									

[15] Steel

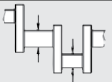
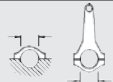



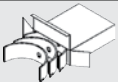

[15] Acier

[15] Acciaio

[15] Acero

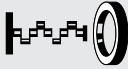





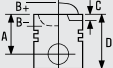
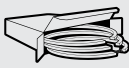

									
BE/PL	4	45.508/45.528	48.629/48.646	19.200	1.547	0.020/0.069	AL-LF	1645RA	<b>01-4127/4</b> STD 0.25 0.50
MB/HL 1,2,4,5	4	50.780/50.800	54.507/54.520	20.250	1.849	0.020/0.067	AL-LF	1646RA	<b>H1075/5</b> STD 0.25 0.50
MB/HL 3	1	50.780/50.800	54.507/54.520	22.750	1.849	0.020/0.067	AL-LF	1647RA	
TW/A	2	56.610/56.864	69.596/69.850		2.362		AL-LF	60987AFA	<b>A198/2</b> STD .005
SE/PB	1	21.539/21.641	23.939/23.972	25.100			BS	62039Y	<b>55-4288</b> SEMI

**1203**  **86.40** **Petrol**



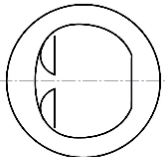





		
<b>ET400</b>	<b>JJ298</b> (Cork) <b>JJ413</b>    <b>JJ298</b> <b>JJ413</b>	<b>NA5051</b>  40.00x56.00x7.00mm, FPM <b>NA5049</b>  64.00x80.00x8.00mm, ACM

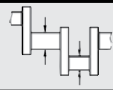

**1204**  **86.40** **Petrol** 

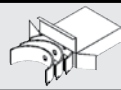

<b>176 A9.000</b>	4 Cyl.	9.5:1	1581cc	<b>65kW (88)PS</b>	<b>TD1039</b>	<b>547</b>
<b>220 A 2.000</b>	4 Cyl.		1581cc	<b>58kW (79)PS</b>	<b>TD6826</b>	<b>558</b>

			
<b>87-783700-00</b> STD <b>87-783706-00</b> 0.40mm <b>87-783708-00</b> 0.60mm  <b>A</b> 33.30 <b>B-</b> 2.30 <b>D</b> 72.80  22x63	  	<b>08-783700-00</b> STD <b>08-783706-00</b> 0.40mm <b>08-783708-00</b> 0.60mm <b>08-783711-00</b> 1.00mm  <b>1.50</b>  CR P <b>1.75</b>  P <b>3.00</b>  CR [15]	

[15] Steel                      [15] Acier                      [15] Acciaio                      [15] Acero

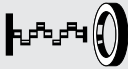
									
BE/PL	4	45.508/45.528	48.629/48.646	19.200	1.547	0.020/0.069	AL-LF	1645RA	<b>01-4127/4</b> STD 0.25 0.50
MB/HL 1,2,4,5	4	50.780/50.800	54.507/54.520	20.250	1.849	0.020/0.067	AL-LF	1646RA	<b>H1075/5</b> STD 0.25 0.50
MB/HL 3	1	50.780/50.800	54.507/54.520	22.750	1.849	0.020/0.067	AL-LF	1647RA	
TW/A	2	56.610/56.864	69.596/69.850		2.362		AL-LF	60987AFA	<b>A198/2</b> STD .005
SE/PB	1	21.539/21.641	23.939/23.972	25.100			BS	62039Y	<b>55-4288</b> SEMI

**ET400**  **JJ453**  



<b>ET400</b>	<b>JJ453</b>   <b>JJ453</b>	<b>NB818</b>  40.00x56.00x7.00mm, ACM <b>NF887</b>  [19] 64.00x112.50x20.00mm, FPM
--------------	---	---







[19] Specification: Oil Seal in housing

[19] Caractéristiques: Bague d'étanchéité dans son logement

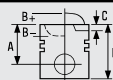
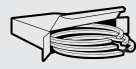

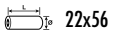
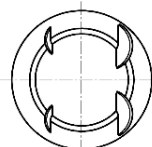
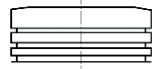





[19] Specifiche: Paraolio in sede



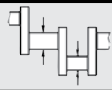
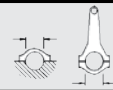

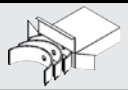

[19] Especificaciones: Retén de aceite de la carcasa

**1205**  **86.40** **Petrol**   
**178 B3.000** 4 Cyl. 10.15:1 158lcc **74-78kW (100-106)PS** **TD10187** **548**

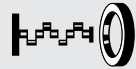

			
<b>87-786800-00</b> STD <b>87-786806-00</b> 0.40mm	<b>08-786800-00</b> STD <b>08-786806-00</b> 0.40mm		
<b>A</b> 34.17 <b>B+</b> 0.25 <b>D</b> 59.42  22x56	 	1.50  CR P 1.50  P 3.00  CR [15]	









[15] Steel [15] Acier [15] Acciaio [15] Acero



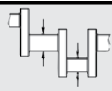
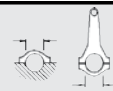

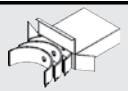

									
BE/PL 4 45.508/45.528 48.629/48.646 19.200 1.547 0.020/0.069 AL-LF 1645RA <b>01-4127/4</b> STD 0.25 0.50	MB/HL 1,2,4,5 4 50.780/50.800 54.507/54.520 20.250 1.849 0.020/0.067 AL-LF 1646RA <b>H1075/5</b> STD 0.25 0.50	MB/HL 3 1 50.780/50.800 54.507/54.520 22.750 1.849 0.020/0.067 AL-LF 1647RA	TW/A 2 56.610/56.864 69.596/69.850 2.362 AL-LF 60987AFA <b>A198/2</b> STD .005	SE/PB 1 21.539/21.641 23.939/23.972 25.100 BS 62039Y <b>55-4288</b> SEMI					

		
<b>ET400</b>	<b>HR397</b>	<b>NA5051</b>  40.00x56.00x7.00mm, FPM <b>NB818</b>  40.00x56.00x7.00mm, ACM <b>NF887</b>  [19] 64.00x112.50x20.00mm, FPM

[19] Specification: Oil Seal in housing [19] Caractéristiques: Bague d'étanchéité dans son logement [19] Specifiche: Paraolio in sede [19] Especificaciones: Retén de aceite de la carcasa

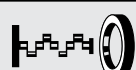
**1206**  **86.40** **Petrol**   
**178 C7.098** 4 Cyl. 10.5:1 158lcc **68-76kW (92-103)PS** **TD18896** **549**  
**182 B5.098** 4 Cyl. 10.5:1 158lcc **72kW (98)PS** **TD19060** **554**

									
BE/PL 4 45.508/45.528 48.629/48.646 19.200 1.547 0.020/0.069 AL-LF 1645RA <b>01-4127/4</b> STD 0.25 0.50	MB/HL 1,2,4,5 4 50.780/50.800 54.507/54.520 20.250 1.849 0.020/0.067 AL-LF 1646RA <b>H1075/5</b> STD 0.25 0.50	MB/HL 3 1 50.780/50.800 54.507/54.520 22.750 1.849 0.020/0.067 AL-LF 1647RA	TW/A 2 56.610/56.864 69.596/69.850 2.362 AL-LF 60987AFA <b>A198/2</b> STD .005	SE/PB 1 21.539/21.641 23.939/23.972 25.100 BS 62039Y <b>55-4288</b> SEMI					

		
<b>EB5150</b>	<b>HR397</b>	<b>NA5051</b>  40.00x56.00x7.00mm, FPM <b>NB818</b>  40.00x56.00x7.00mm, ACM <b>NF887</b>  [19] 64.00x112.50x20.00mm, FPM

[19] Specification: Oil Seal in housing [19] Caractéristiques: Bague d'étanchéité dans son logement [19] Specifiche: Paraolio in sede [19] Especificaciones: Retén de aceite de la carcasa







<b>1207</b>		<b>86.40</b>		<b>Petrol</b>						
<b>178 D2.011</b>		4 Cyl.	10.5:1	1581cc	<b>68-76kW (92-103)PS</b>				<b>TD18897</b>	<b>550</b>
BE/PL	4	45.508/45.528	48.629/48.646	19.200	1.547	0.020/0.069	AL-LF	1645RA	<b>01-4127/4</b> STD 0.25 0.50	
MB/HL 1,2,4,5	4	50.780/50.800	54.507/54.520	20.250	1.849	0.020/0.067	AL-LF	1646RA	<b>H1075/5</b> STD 0.25 0.50	
MB/HL 3	1	50.780/50.800	54.507/54.520	22.750	1.849	0.020/0.067	AL-LF	1647RA		
TW/A	2	56.610/56.864	69.596/69.850		2.362		AL-LF	60987AFA	<b>A198/2</b> STD .005	
SE/PB	1	21.539/21.641	23.939/23.972	25.100			BS	62039Y	<b>55-4288</b> SEMI	
EB5150			HR397			NA5051  40.00x56.00x7.00mm, FPM NB818  40.00x56.00x7.00mm, ACM				

<b>1208</b>		<b>86.40</b>		<b>Petrol</b>						
<b>182 A4.000</b>		4 Cyl.	10.5:1	1581cc	<b>76kW (103)PS</b>				<b>TD4400</b>	<b>551</b>
<b>185 A3.000 Euro 3 (D3)</b>		4 Cyl.	10.1:1	1581cc	<b>68-76kW (92-103)PS</b>				<b>TD15650</b>	<b>555</b>
<b>87-786800-00</b>	STD			<b>08-786800-00</b>	STD					
<b>87-786806-00</b>	0.40mm			<b>08-786806-00</b>	0.40mm					
<b>A</b> 34.17				1.50		CR P				
<b>B+</b> 0.25				1.50		P				
<b>D</b> 59.42				3.00		CR [15]				
	22x56									
[15] Steel		[15] Acier		[15] Acciaio			[15] Acero			

BE/PL	4	45.508/45.528	48.629/48.646	19.200	1.547	0.020/0.069	AL-LF	1645RA	<b>01-4127/4</b> STD 0.25 0.50	
MB/HL 1,2,4,5	4	50.780/50.800	54.507/54.520	20.250	1.849	0.020/0.067	AL-LF	1646RA	<b>H1075/5</b> STD 0.25 0.50	
MB/HL 3	1	50.780/50.800	54.507/54.520	22.750	1.849	0.020/0.067	AL-LF	1647RA		
TW/A	2	56.610/56.864	69.596/69.850		2.362		AL-LF	60987AFA	<b>A198/2</b> STD .005	
SE/PB	1	21.539/21.641	23.939/23.972	25.100			BS	62039Y	<b>55-4288</b> SEMI	









...Continued

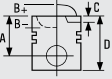



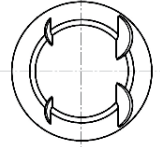

**1208**  **86.40** **Petrol**



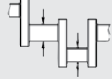
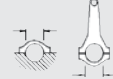

		
<b>EB5150</b>	<b>JJ453</b>	<b>NA5051</b>  40.00x56.00x7.00mm, FPM <b>NB818</b>  40.00x56.00x7.00mm, ACM <b>NF887</b>  [19] 64.00x112.50x20.00mm, FPM
		
	<b>JJ453</b>	
[19] Specification: Oil Seal in housing	[19] Caratteristiche: Bague d'étanchéité dans son logement	[19] Specifiche: Paraolio in sede
		[19] Especificaciones: Retén de aceite de la carcasa

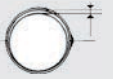
**1209**  **86.40** **Petrol** 

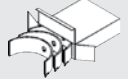
<b>182 A4.000</b>	4 Cyl.	10.2:1	1581cc	<b>76kW (103)PS</b>	<b>TD9476</b>	<b>552</b>
<b>182 A6.000</b>	4 Cyl.	10.1:1	1581cc	<b>66kW (90)PS</b>	<b>TD9475</b>	<b>552</b>

			
<b>87-786800-00</b> STD <b>87-786806-00</b> 0.40mm	<b>08-786800-00</b> STD <b>08-786806-00</b> 0.40mm		
<b>A</b> 34.17 <b>B+</b> 0.25 <b>D</b> 59.42  22x56	 	1.50  CR P 1.50  P 3.00  CR [15]	
[15] Steel	[15] Acier	[15] Acciaio	[15] Acero

									
BE/PL	4	45.508/45.528	48.629/48.646	19.200	1.547	0.020/0.069	AL-LF	1645RA	<b>01-4127/4</b> STD 0.25 0.50
MB/HL 1,2,4,5	4	50.780/50.800	54.507/54.520	20.250	1.849	0.020/0.067	AL-LF	1646RA	<b>H1075/5</b> STD 0.25 0.50
MB/HL 3	1	50.780/50.800	54.507/54.520	22.750	1.849	0.020/0.067	AL-LF	1647RA	
TW/A	2	56.610/56.864	69.596/69.850		2.362		AL-LF	60987AFA	<b>A198/2</b> STD .005
SE/PB	1	21.539/21.641	23.939/23.972	25.100			BS	62039Y	<b>55-4288</b> SEMI

		
	<b>HR397</b>	<b>NB818</b>  40.00x56.00x7.00mm, ACM <b>NF887</b>  [19] 64.00x112.50x20.00mm, FPM
[19] Specification: Oil Seal in housing	[19] Caratteristiche: Bague d'étanchéité dans son logement	[19] Specifiche: Paraolio in sede
		[19] Especificaciones: Retén de aceite de la carcasa

# FIAT GROUP

## 1210

86.40

**Petrol**



182 A6.000

4 Cyl.

10.1:1

1581cc

66kW (90)PS

TD4402

553

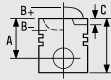

87-786800-00  
87-786806-00

STD  
0.40mm

A 34.17  
B+ 0.25  
D 59.42  
 22x56

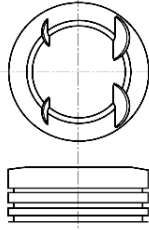

08-786800-00 STD  
08-786806-00 0.40mm

1.50 CR P  
1.50 P  
3.00 CR [15]

[15] Steel

[15] Acier

[15] Acciaio

[15] Acero

BE/PL	4	45.508/45.528	48.629/48.646	19.200	1.547	0.020/0.069	AL-LF	1645RA	<b>01-4127/4</b> STD 0.25 0.50	
MB/HL 1,2,4,5	4	50.780/50.800	54.507/54.520	20.250	1.849	0.020/0.067	AL-LF	1646RA	<b>H1075/5</b> STD 0.25 0.50	
MB/HL 3	1	50.780/50.800	54.507/54.520	22.750	1.849	0.020/0.067	AL-LF	1647RA		
TW/A	2	56.610/56.864	69.596/69.850	2.362			AL-LF	60987AFA	<b>A198/2</b> STD .005	
SE/PB	1	21.539/21.641	23.939/23.972	25.100			BS	62039Y	<b>55-4288</b> SEMI	

<b>EB5150</b>	<b>JJ453</b>	<b>NB818</b> 40.00x56.00x7.00mm, ACM	<b>NF887</b> [19] 64.00x112.50x20.00mm, FPM
	<b>JJ453</b>		
[19] Specification: Oil Seal in housing	[19] Caractéristiques: Bague d'étanchéité dans son logement	[19] Specifiche: Paraolio in sede	[19] Especificaciones: Retén de aceite de la carcasa

## 1211

86.40

**LPG**



186 A3.000

4 Cyl.

12.5:1

1581cc

70kW (95)PS

TD11787

556

BE/PL	4	45.508/45.528	48.629/48.646	19.200	1.547	0.020/0.069	AL-LF	1645RA	<b>01-4127/4</b> STD 0.25 0.50	
MB/HL 1,2,4,5	4	50.780/50.800	54.507/54.520	20.250	1.849	0.020/0.067	AL-LF	1646RA	<b>H1075/5</b> STD 0.25 0.50	
MB/HL 3	1	50.780/50.800	54.507/54.520	22.750	1.849	0.020/0.067	AL-LF	1647RA		
TW/A	2	56.610/56.864	69.596/69.850	2.362			AL-LF	60987AFA	<b>A198/2</b> STD .005	
SE/PB	1	21.539/21.641	23.939/23.972	25.100			BS	62039Y	<b>55-4288</b> SEMI	



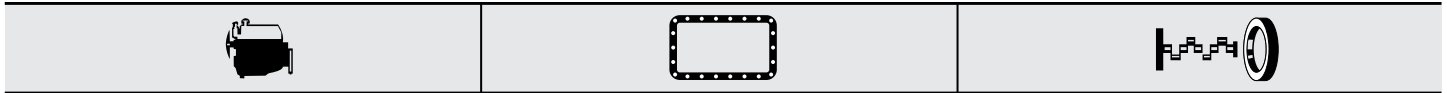

...Continued

**1211**  **86.40** **LPG**



JJ453

**NA5051**  40.00x56.00x7.00mm, FPM  
**NB818**  40.00x56.00x7.00mm, ACM  
**NF887**  [19] 64.00x112.50x20.00mm, FPM





JJ453

[19] Specification: Oil Seal in housing









[19] Caractéristiques: Bague d'étanchéité dans son logement

[19] Specifiche: Paraolio in sede

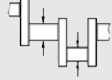
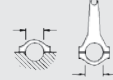
[19] Especificaciones: Retén de aceite de la carcasa

**1212**  **86.40** **Petrol** 

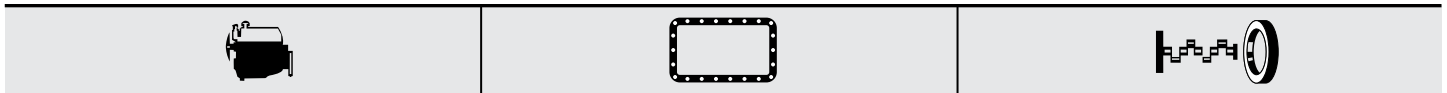

**186 A4.000** 4 Cyl. 10.5:1 1581cc **68-76kW (92-103)PS** **TD11788** **557**

									
BE/PL	4	45.508/45.528	48.629/48.646	19.200	1.547	0.020/0.069	AL-LF	1645RA	<b>01-4127/4</b> STD 0.25 0.50
MB/HL 1,2,4,5	4	50.780/50.800	54.507/54.520	20.250	1.849	0.020/0.067	AL-LF	1646RA	<b>H1075/5</b> STD 0.25 0.50
MB/HL 3	1	50.780/50.800	54.507/54.520	22.750	1.849	0.020/0.067	AL-LF	1647RA	
TW/A	2	56.610/56.864	69.596/69.850		2.362		AL-LF	60987AFA	<b>A198/2</b> STD .005
SE/PB	1	21.539/21.641	23.939/23.972	25.100			BS	62039Y	<b>55-4288</b> SEMI



 EB5150

JJ453

**NA5051**  40.00x56.00x7.00mm, FPM  
**NB818**  40.00x56.00x7.00mm, ACM  
**NF887**  [19] 64.00x112.50x20.00mm, FPM





JJ453

[19] Specification: Oil Seal in housing







[19] Caractéristiques: Bague d'étanchéité dans son logement

[19] Specifiche: Paraolio in sede

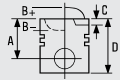
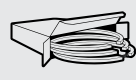
[19] Especificaciones: Retén de aceite de la carcasa

**1213**  **86.40** **Petrol** 

**835 A1.000** 4 Cyl. 9.2:1 1581cc **65-66kW (88-90)PS** **TD1842** **559**

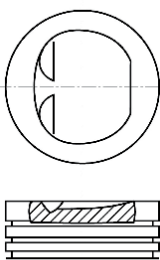
			
<b>87-783700-00</b> STD	<b>08-783700-00</b> STD		
<b>87-783706-00</b> 0.40mm	<b>08-783706-00</b> 0.40mm		
<b>87-783708-00</b> 0.60mm	<b>08-783708-00</b> 0.60mm		
	<b>08-783711-00</b> 1.00mm		
<b>A</b> 33.30	1.50  CR P		
<b>B-</b> 2.30	1.75  P		
<b>D</b> 72.80	3.00  CR [15]		
 22x63			









[15] Steel

[15] Acier

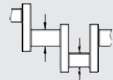
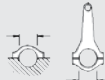
[15] Acciaio

[15] Acero

**1213**  **86.40** **Petrol**

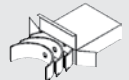
									
BE/PL	4	45.508/45.528	48.629/48.646	19.200	1.547	0.020/0.069	AL-LF	1645RA	<b>01-4127/4</b> STD 0.25 0.50
MB/HL 1,2,4,5	4	50.780/50.800	54.507/54.520	20.250	1.849	0.020/0.067	AL-LF	1646RA	<b>H1075/5</b> STD 0.25 0.50
MB/HL 3	1	50.780/50.800	54.507/54.520	22.750	1.849	0.020/0.067	AL-LF	1647RA	
TW/A	2	56.610/56.864	69.596/69.850		2.362		AL-LF	60987AFA	<b>A198/2</b> STD .005
SE/PB	1	21.539/21.641	23.939/23.972	25.100			BS	62039Y	<b>55-4288</b> SEMI

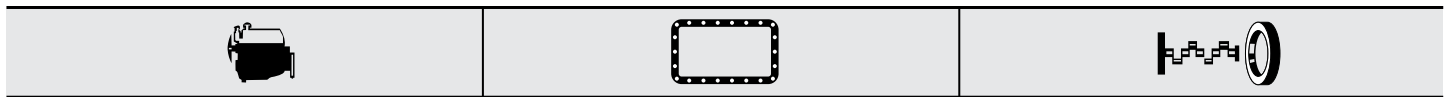

 **ET400**

**JJ453**

**NF887**  [19] 64.00x112.50x20.00mm, FPM



**JJ453**

[19] Specification: Oil Seal in housing







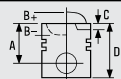
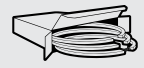

[19] Caractéristiques: Bague d'étanchéité dans son logement

[19] Specifiche: Paraolio in sede

[19] Especificaciones: Retén de aceite de la carcasa

**1214**  **86.40** **Petrol**

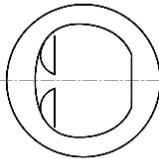
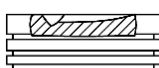
<b>835 A1.046</b>	4 Cyl.	9.2:1	1581cc	<b>57kW (77)PS</b>	<b>TD1843</b>	<b>560</b>
<b>835 C1.000</b>	4 Cyl.	9.2:1	1581cc	<b>55kW (75)PS</b>	<b>TD4611</b>	<b>561</b>









			
<p><b>87-783700-00</b> STD</p> <p><b>87-783706-00</b> 0.40mm</p> <p><b>87-783708-00</b> 0.60mm</p> <p><b>A</b> 33.30</p> <p><b>B-</b> 2.30</p> <p><b>D</b> 72.80</p> <p> 22x63</p>	<p><b>08-783700-00</b> STD</p> <p><b>08-783706-00</b> 0.40mm</p> <p><b>08-783708-00</b> 0.60mm</p> <p><b>08-783711-00</b> 1.00mm</p> <p>1.50  CR P</p> <p>1.75  P</p> <p>3.00  CR [15]</p>		
			

[15] Steel

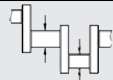
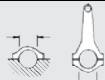
[15] Acier



[15] Acciaio

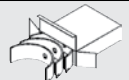

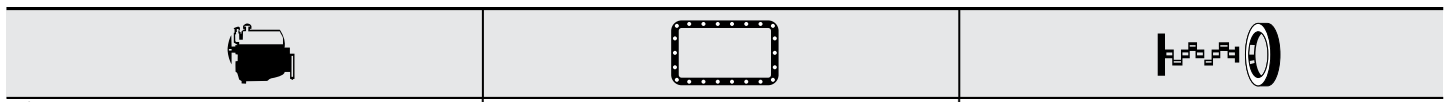



[15] Acero

									
BE/PL	4	45.508/45.528	48.629/48.646	19.200	1.547	0.020/0.069	AL-LF	1645RA	<b>01-4127/4</b> STD 0.25 0.50
MB/HL 1,2,4,5	4	50.780/50.800	54.507/54.520	20.250	1.849	0.020/0.067	AL-LF	1646RA	<b>H1075/5</b> STD 0.25 0.50
MB/HL 3	1	50.780/50.800	54.507/54.520	22.750	1.849	0.020/0.067	AL-LF	1647RA	
TW/A	2	56.610/56.864	69.596/69.850		2.362		AL-LF	60987AFA	<b>A198/2</b> STD .005
SE/PB	1	21.539/21.641	23.939/23.972	25.100			BS	62039Y	<b>55-4288</b> SEMI

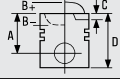
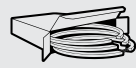

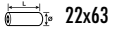
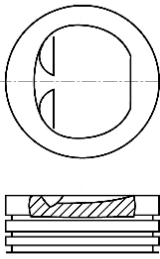









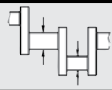
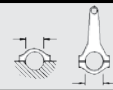



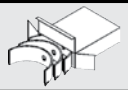

 **ET400**



**1215**  **86.40** **Petrol**   
**835 C1.000** 4 Cyl. 9.2:1 1581cc **55-57kW (75-78)PS** **TD1067** **562**







			
<b>87-783700-00</b> STD <b>87-783706-00</b> 0.40mm <b>87-783708-00</b> 0.60mm  <b>A</b> 33.30 <b>B-</b> 2.30 <b>D</b> 72.80  22x63	  <b>08-783700-00</b> STD <b>08-783706-00</b> 0.40mm <b>08-783708-00</b> 0.60mm <b>08-783711-00</b> 1.00mm  <b>1.50</b>  CR P <b>1.75</b>  P <b>3.00</b>  CR [15]		

[15] Steel [15] Acier [15] Acciaio [15] Acero

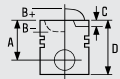
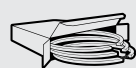
									
BE/PL	4	45.508/45.528	48.629/48.646	19.200	1.547	0.020/0.069	AL-LF	1645RA	<b>01-4127/4</b> STD 0.25 0.50
MB/HL 1,2,4,5	4	50.780/50.800	54.507/54.520	20.250	1.849	0.020/0.067	AL-LF	1646RA	<b>H1075/5</b> STD 0.25 0.50
MB/HL 3	1	50.780/50.800	54.507/54.520	22.750	1.849	0.020/0.067	AL-LF	1647RA	
TW/A	2	56.610/56.864	69.596/69.850		2.362		AL-LF	60987AFA	<b>A198/2</b> STD .005
SE/PB	1	21.539/21.641	23.939/23.972	25.100			BS	62039Y	<b>55-4288</b> SEMI

			
ET400	JJ453	JJ453	<b>NA5051</b>  40.00x56.00x7.00mm, FPM <b>NB818</b>  40.00x56.00x7.00mm, ACM <b>NA5049</b>  64.00x80.00x8.00mm, ACM <b>NB808</b>  64.00x80.00x8.00mm, FPM

**1216**  **87.00** **Petrol**   
**AR 30550** 4 Cyl. 9.5:1 1712cc **84-95kW (114-129)PS** **TD4186** **563**









			
	<b>08-110300-00</b> STD  <b>1.50</b>  CR P <b>1.75</b>  P <b>3.00</b>  CR [15]		

[15] Steel [15] Acier [15] Acciaio [15] Acero

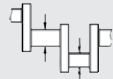
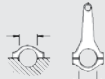
# FIAT GROUP

...Continued

## 1216 87.00 Petrol

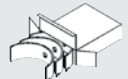
									
BE/PL	4	49.984/50.000	53.696/53.708	17.800	1.836	0.024/0.077	AL-LF	66325RA	<b>01-4178/4</b> STD 0.25 0.50
BE/PL	4	49.992/50.000	53.696/53.708	17.800	1.836	0.024/0.069	AL-LF	66625RA	<b>01-4188/4</b> STD 0.25 0.50

66325RA

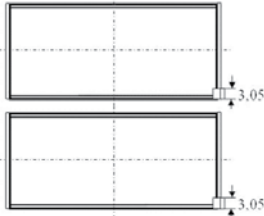

66625RA

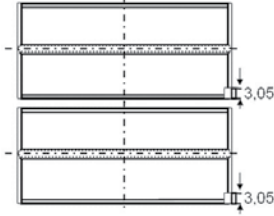

MB/HL 1-3	3	59.944/59.957	63.663/63.673	23.400	1.841	0.024/0.072	AL-LF	66326RA	<b>H1044/3</b> STD 0.25 0.50
TW/A	2	65.790/66.040	82.420/82.680		2.362		BS	66326AF	<b>A205/2</b> STD
SE/PB	1	20.996/21.000	23.005/23.020	23.500			BS	66329Y	<b>55-4505</b> SEMI

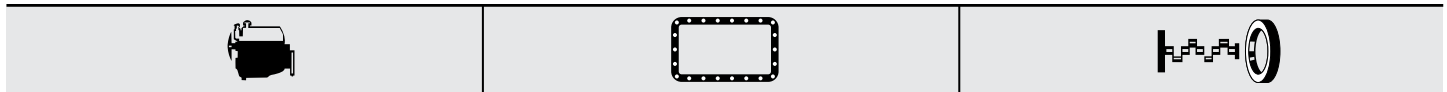

JH565



JH565



NA5063  40.00x56.00x10.00mm, ACM

## 1217 87.00 Petrol

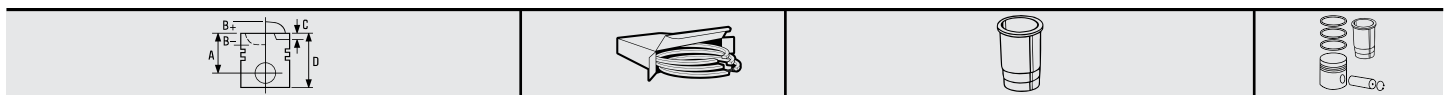
AR 30558	4 Cyl.	1712cc	<b>77kW (105)PS</b>	<b>TD93</b>	<b>564</b>
AR 30736	4 Cyl.	1712cc	<b>79kW (107)PS</b>	<b>TD109</b>	<b>565</b>
AR 30737	4 Cyl.	1712cc	<b>77-79kW (105-107)PS</b>	<b>TD110</b>	<b>565</b>



**08-110300-00** STD

1.50		CR P
1.75		P
3.00		CR [15]

[15] Steel









[15] Acier

[15] Acciaio

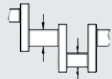
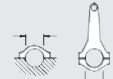
[15] Acero

...Continued

**1217**  **87.00** **Petrol**

									
BE/PL	4	49.984/50.000	53.696/53.708	17.800	1.836	0.024/0.077	AL-LF	66325RA	<b>01-4178/4</b> STD 0.25 0.50
BE/PL	4	49.992/50.000	53.696/53.708	17.800	1.836	0.024/0.069	AL-LF	66625RA	<b>01-4188/4</b> STD 0.25 0.50

66325RA

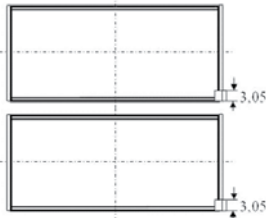

66625RA

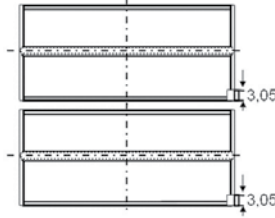

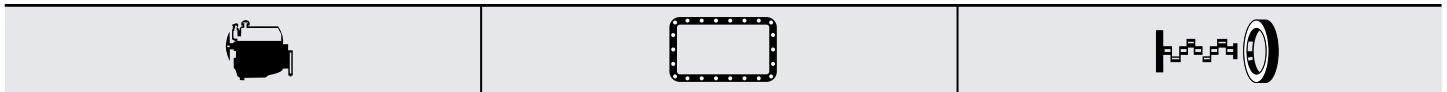

MB/HL 1-3	3	59.944/59.957	63.663/63.673	23.400	1.841	0.024/0.072	AL-LF	66326RA	<b>H1044/3</b> STD 0.25 0.50
TW/A	2	65.790/66.040	82.420/82.680		2.362		BS	66326AF	<b>A205/2</b> STD
SE/PB	1	20.996/21.000	23.005/23.020	23.500			BS	66329Y	<b>55-4505</b> SEMI



JH565









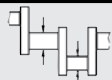
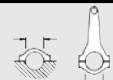

JH565

**NA5063**  40.00x56.00x10.00mm, ACM  
**NA5065**  62.00x80.00x12.00mm, ACM

**1218**  **87.00** **Petrol** 

**AR 30578**      4 Cyl.      9.5:1      1712cc      **79kW (107)PS**      **TD95**

									
BE/PL	4	49.984/50.000	53.696/53.708	17.800	1.836	0.024/0.077	AL-LF	66325RA	<b>01-4178/4</b> STD 0.25 0.50
BE/PL	4	49.992/50.000	53.696/53.708	17.800	1.836	0.024/0.069	AL-LF	66625RA	<b>01-4188/4</b> STD 0.25 0.50

66325RA

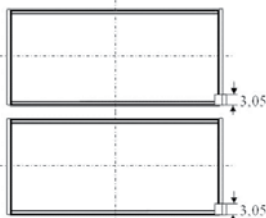

66625RA

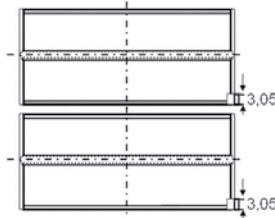

MB/HL 1-3	3	59.944/59.957	63.663/63.673	23.400	1.841	0.024/0.072	AL-LF	66326RA	<b>H1044/3</b> STD 0.25 0.50
TW/A	2	65.790/66.040	82.420/82.680		2.362		BS	66326AF	<b>A205/2</b> STD
SE/PB	1	20.996/21.000	23.005/23.020	23.500			BS	66329Y	<b>55-4505</b> SEMI

# FIAT GROUP

## 1219

87.00

**Petrol**



AR 30737 A

4 Cyl.

1712cc

77-79kW (105-107)PS

TD111

566

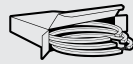
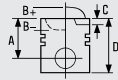

08-110300-00

STD

1.50



CR P

1.75



P

3.00



CR [15]

[15] Steel

[15] Acier

[15] Acciaio

[15] Acero

BE/PL	4	49.984/50.000	53.696/53.708	17.800	1.836	0.024/0.077	AL-LF	66325RA	01-4178/4 STD 0.25 0.50
BE/PL	4	49.992/50.000	53.696/53.708	17.800	1.836	0.024/0.069	AL-LF	66625RA	01-4188/4 STD 0.25 0.50

66325RA

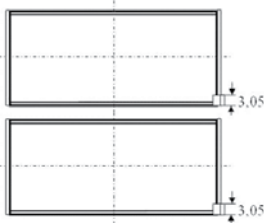

66625RA

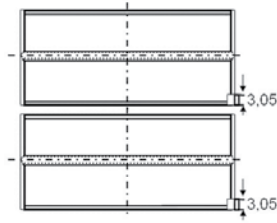

MB/HL 1-3	3	59.944/59.957	63.663/63.673	23.400	1.841	0.024/0.072	AL-LF	66326RA	H1044/3 STD 0.25 0.50
TW/A	2	65.790/66.040	82.420/82.680		2.362		BS	66326AF	A205/2 STD
SE/PB	1	20.996/21.000	23.005/23.020	23.500			BS	66329Y	55-4505 SEMI

## 1220

87.00

**Petrol**



AR 30740

4 Cyl.

1712cc

77kW (105)PS

TD112

567

BE/PL	4	49.984/50.000	53.696/53.708	17.800	1.836	0.024/0.077	AL-LF	66325RA	01-4178/4 STD 0.25 0.50
BE/PL	4	49.992/50.000	53.696/53.708	17.800	1.836	0.024/0.069	AL-LF	66625RA	01-4188/4 STD 0.25 0.50

66325RA

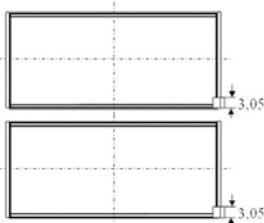



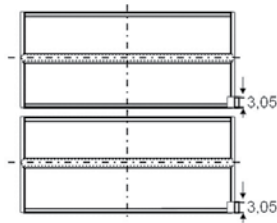





66625RA











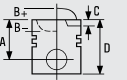





MB/HL 1-3	3	59.944/59.957	63.663/63.673	23.400	1.841	0.024/0.072	AL-LF	66326RA	H1044/3 STD 0.25 0.50
TW/A	2	65.790/66.040	82.420/82.680		2.362		BS	66326AF	A205/2 STD
SE/PB	1	20.996/21.000	23.005/23.020	23.500			BS	66329Y	55-4505 SEMI



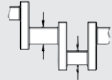



...Continued

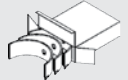

<b>1220</b>	 <b>87.00</b>	<b>Petrol</b>
		
	<b>JH565</b>	<b>NA5063</b>  40.00x56.00x10.00mm, ACM <b>NA5065</b>  62.00x80.00x12.00mm, ACM
	 <b>JH565</b>	





<b>1221</b>	 <b>87.00</b>	<b>Petrol</b>		
<b>AR 30746</b>	4 Cyl.	1712cc	<b>101kW (137)PS</b>	<b>TD114</b> <b>568</b>
<b>AR 30747</b>	4 Cyl.	1712cc	<b>95-97kW (129-132)PS</b>	<b>TD115</b> <b>568</b>
<b>AR 33401</b>	4 Cyl.	1712cc	<b>95kW (129)PS</b>	<b>TD122</b> <b>569</b>

			
	<b>08-110300-00</b> STD		
	1.50  CR P		
	1.75  P		
	3.00  CR [15]		
[15] Steel	[15] Acier	[15] Acciaio	[15] Acero







									
BE/PL	4	49.984/50.000	53.696/53.708	17.800	1.836	0.024/0.077	BS	4075CP	<b>71-4250/4</b> STD 0.25 0.50
MB/HL 1-3	3	59.944/59.964	63.663/63.673	23.400	1.842	0.020/0.070	BS	4076CP	<b>H1081/3</b> STD 0.25
TW/A	2	65.790/66.040	82.420/82.680		2.362		BS	66326AF	<b>A205/2</b> STD
SE/PB	1	20.996/21.000	23.005/23.020	23.500			BS	66329Y	<b>55-4505</b> SEMI







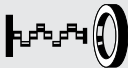

		
	<b>JH565</b>	<b>NA5063</b>  40.00x56.00x10.00mm, ACM <b>NA5065</b>  62.00x80.00x12.00mm, ACM
	 <b>JH565</b>	



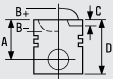



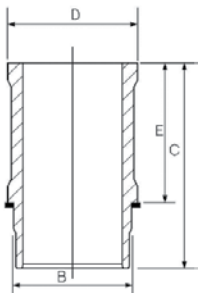

<b>1222</b>	 <b>87.00</b>	<b>Petrol</b>			
<b>ES9 J4S</b>	6 Cyl.	10.9:1	2946cc	<b>150kW (204)PS</b>	<b>TD17397</b> <b>570</b>

		
	<b>HR397</b>	<b>NA5260</b>  38.00x50.00x6.00mm, FPM <b>NF867</b>  98.00x120.00x7.00mm, FPM/ACM

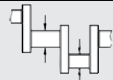
# FIAT GROUP

<b>1223</b>	 <b>87.00</b>	<b>Petrol</b>	
<b>XFW</b>	6 Cyl.	10.9:1	2946cc
			<b>150-152kW (204-207)PS</b>
			<b>TD18310 572</b>
			
	<b>HR397</b>	<b>NA5177</b>  42.00x56.00x7.00mm, FPM	<b>NF867</b>  98.00x120.00x7.00mm, FPM/ACM

<b>1224</b>	 <b>88.00</b>	<b>Petrol</b>	
<b>170 B</b>	4 Cyl.	1971cc	<b>55kW (75)PS</b>
<b>170 D</b>	4 Cyl.	1971cc	<b>62kW (84)PS</b>
			
	<b>08-316900-00</b> STD <b>08-316907-00</b> 0.50mm  1.50  CR P 2.00  P 4.00  CR [15]	<b>14-636500-00 WH</b> <b>B 93.00 C 135.70 D 101.90 E 89.99</b>  	
[15] Steel	[15] Acier	[15] Acciaio	[15] Acero

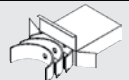
									
BE/PL	4	49.975/49.991	53.655/53.674	23.400	1.818	0.030/0.080	AL-LF	2865RA	<b>01-4558/4</b> STD 0.30 0.50 0.80 1.00
MB/HL 1	1	59.401/59.416	63.227/63.246	29.500	1.888	0.040/0.080	AL-LF	2866RA	<b>H1240/5</b> STD 0.30 0.50 0.80
MB/HL 2	1	58.548/58.573	62.384/62.403	21.500	1.888	0.040/0.080	AL-LF	61902RA	
MB/HL 3	1	57.174/57.189	61.000/61.019	29.500	1.888	0.040/0.080	AL-LF	61903RA	
MB/HL 4	1	56.140/56.165	59.976/59.995	21.500	1.888	0.040/0.080	AL-LF	61903RAA	
MB/HL 5	1	54.905/54.920	58.731/58.750	29.350	1.888	0.040/0.080	AL-LF	61904RA	
<b>→12/80</b>									
MB/HL 5	1	54.905/54.920	58.731/58.750	29.350	1.900	0.040/0.080	AL-LF	66696RA	<b>H1241/5</b> STD 0.30 0.50 0.80
MB/HL 4	1	56.140/56.165	59.976/59.995	21.500	1.900	0.040/0.080	AL-LF	66697RA	
MB/HL 3	1	57.174/57.189	61.000/61.019	29.500	1.900	0.040/0.080	AL-LF	66698RA	
MB/HL 2	1	58.548/58.573	62.384/62.403	21.500	1.900	0.040/0.080	AL-LF	66699RA	
MB/HL 1	1	59.401/59.416	63.227/63.246	29.500	1.900	0.040/0.080	AL-LF	66699RAA	
<b>01/81→</b>									
TW/A	4	61.400/61.650	72.550/72.800		2.330		AL-LF	61904BF	<b>A199/4</b> STD 0.10 0.15 0.20
SE/PB	1	22.700/22.850	24.350/24.383	27.000			BS	2514X	<b>55-4134</b> SEMI



...Continued

<b>1224</b>	<b>88.00</b>	<b>Petrol</b>
<b>NA5191</b> 42.00x62.00x7.00mm, PTFE		

<b>1225</b>	<b>88.00</b>	<b>Petrol</b>	
<b>XN 1T</b>	4 Cyl.	8:1	1971cc
<b>58-60kW (79-82)PS</b>			
			<b>TD4418 576</b>

<p>[12]</p> <p><b>A</b> 38.25</p> <p><b>B+</b> 0.65</p> <p><b>D</b> 71.85</p> <p> 23x74</p>	  	<p><b>08-316900-00</b> STD</p> <p><b>08-316907-00</b> 0.50mm</p> <p>1.50  CR P</p> <p>2.00  P</p> <p>4.00  CR [15]</p>	<p><b>14-636500-00 WH</b></p> <p><b>B</b> 93.00 <b>C</b> 135.70 <b>D</b> 101.90 <b>E</b> 89.99</p> <p style="text-align: center;"></p>	<p><b>89-316900-00</b></p>
<p>[12]</p> <p><b>A</b> 37.90</p> <p><b>B+</b> 1.35</p> <p><b>D</b> 72.20</p> <p> 23x74</p>	  	<p><b>08-316900-00</b> STD</p> <p><b>08-316907-00</b> 0.50mm</p> <p>1.50  CR P</p> <p>2.00  P</p> <p>4.00  CR [15]</p>	<p><b>14-636500-00 WH</b></p> <p><b>B</b> 93.00 <b>C</b> 135.70 <b>D</b> 101.90 <b>E</b> 89.99</p> <p style="text-align: center;"></p>	<p><b>89-316900-10</b></p>

[12] Piston available in Kit Set only

[12] Chemise disponible en kit seulement

[12] I pistoni sono disponibili solo in kit motore

[12] Pistón disponible en conjuntos solamente.

[15] Steel

[15] Acier











[15] Acciaio

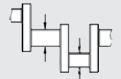



[15] Acero



BE/PL	4	49.975/49.991	53.655/53.674	23.400	1.818	0.030/0.080	AL-LF	2865RA	<p><b>01-4558/4</b></p> <p>STD 0.30 0.50 0.80 1.00</p> <p><b>H1240/5</b></p> <p>STD 0.30 0.50 0.80</p>	
MB/HL 1	1	59.401/59.416	63.227/63.246	29.500	1.888	0.040/0.080	AL-LF	2866RA		
MB/HL 2	1	58.548/58.573	62.384/62.403	21.500	1.888	0.040/0.080	AL-LF	61902RA		
MB/HL 3	1	57.174/57.189	61.000/61.019	29.500	1.888	0.040/0.080	AL-LF	61903RA		
MB/HL 4	1	56.140/56.165	59.976/59.995	21.500	1.888	0.040/0.080	AL-LF	61903RAA		
MB/HL 5	1	54.905/54.920	58.731/58.750	29.350	1.888	0.040/0.080	AL-LF	61904RA		

→12/80









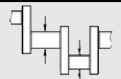

**1225**  **88.00** **Petrol**

									
MB/HL 5	1	54.905/54.920	58.731/58.750	29.350	1.900	0.040/0.080	AL-LF	66696RA	<b>H1241/5</b> STD 0.30 0.50 0.80
MB/HL 4	1	56.140/56.165	59.976/59.995	21.500	1.900	0.040/0.080	AL-LF	66697RA	
MB/HL 3	1	57.174/57.189	61.000/61.019	29.500	1.900	0.040/0.080	AL-LF	66698RA	
MB/HL 2	1	58.548/58.573	62.384/62.403	21.500	1.900	0.040/0.080	AL-LF	66699RA	
MB/HL 1	1	59.401/59.416	63.227/63.246	29.500	1.900	0.040/0.080	AL-LF	66699RAA	
<b>01/81</b> →									
TW/A	4	61.400/61.650	72.550/72.800		2.330		AL-LF	61904BF	<b>A199/4</b> STD 0.10 0.15 0.20
SE/PB	1	22.700/22.850	24.350/24.383	27.000			BS	2514X	<b>55-4134</b> SEMI

		
<b>EM531</b>	<b>PA349</b> 22.00x16.00x2.000mm	<b>NA5191</b>  42.00x62.00x7.00mm, PTFE <b>NA5192</b>  90.00x110.00x7.00mm, PTFE



**1226**  **88.00** **Diesel** 





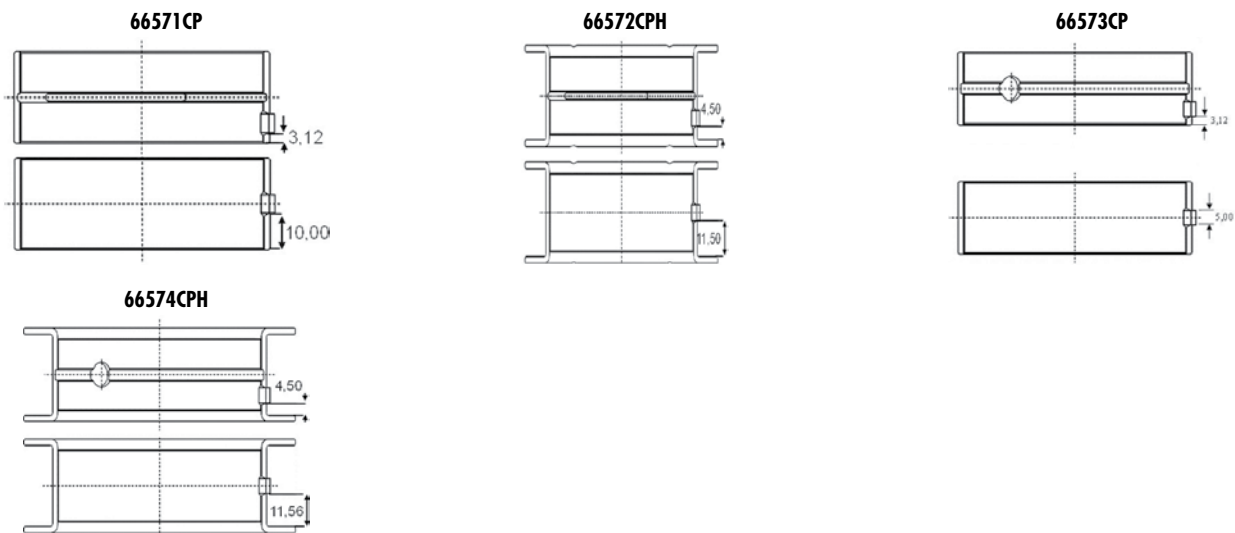



**8144.65** 4 Cyl. 22.1:1 1995cc 44kW (60)PS **TD1055** **577**

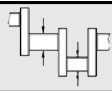
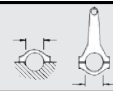

									
MB/HL 1-4	4	76.187/76.200	80.586/80.607	24.990	2.172	0.042/0.100	BS	66571CP	<b>H1049/5</b> STD 0.25 0.50 0.75
MB/HL 5	1	76.187/76.200	80.586/80.607	31.950	2.172	0.042/0.100	BS	66572CPH	
<b>Mot. → 1846776</b>									
MB/HL 1-4	4	76.187/76.200	80.586/80.607	24.990	2.172	0.038/0.097	BS	66573CP	<b>H1094/5</b> STD 0.25
MB/HL 5	1	76.187/76.200	80.586/80.607	31.950	2.172	0.038/0.097	BS	66574CPH	





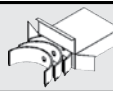

**Mot. 1846777** →



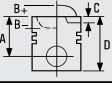
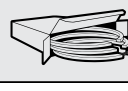







<b>1227</b>	 <b>88.00</b>	<b>Diesel</b>					
<b>VM 4 HT</b>	4 Cyl.	22:1	1995cc	<b>61kW (83)PS</b>	<b>Turbocharged</b>	<b>TD150</b>	<b>578</b>
<b>VM 5 HT</b>	5 Cyl.	22:1	2494cc	<b>77kW (105)PS</b>	<b>Turbocharged</b>	<b>TD10148</b>	

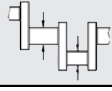
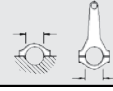

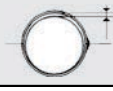

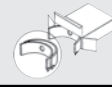
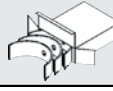

									
BE/PL	1	53.940/53.955	57.563/57.582	23.250	1.798	0.020/0.071	BS	66655CP	<b>71-4234</b> STD 0.25 0.50 0.75
TW/A	2	74.250/74.500	88.000/88.100		2.362		AL-LF	61588AF	<b>A227/2</b> STD
SE/PB	1	29.990/29.996	34.000/34.025	30.120			BS	66659XA	<b>55-4235</b> SEMI

<b>1228</b>	 <b>88.00</b>	<b>Diesel</b>					
<b>VM 80 A</b>	4 Cyl.	22:1	1995cc	<b>70kW (95)PS</b>	<b>Turbocharged</b>	<b>TD151</b>	<b>579</b>
<b>VM4HT/2</b>	4 Cyl.		1995cc	<b>60kW (82)PS</b>	<b>Turbocharged</b>	<b>TD160</b>	<b>579</b>
<b>VM-HR 588 HT</b>	5 Cyl.	22:1	2493cc	<b>76-77kW (103-105)PS</b>	<b>Turbocharged</b>	<b>TD158</b>	<b>604</b>

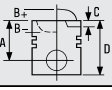
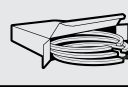



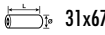

			
	<b>08-110000-00</b> STD		
	2.50  CR P		
	2.00  P		
	4.00  CR P		

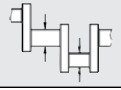
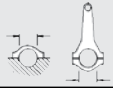

									
BE/PL	1	53.940/53.955	57.563/57.582	23.250	1.798	0.020/0.071	BS	66655CP	<b>71-4234</b> STD 0.25 0.50 0.75
TW/A	2	74.250/74.500	88.000/88.100		2.362		AL-LF	61588AF	<b>A227/2</b> STD
SE/PB	1	29.990/29.996	34.000/34.025	30.120			BS	66659XA	<b>55-4235</b> SEMI

<b>1229</b>	 <b>88.00</b>	<b>Diesel</b>						
<b>F1AE0481A Euro 3 (D3)</b>	4 Cyl.		2287cc	<b>70kW (95)PS</b>			<b>TD17144</b>	<b>582</b>
<b>F1AE0481B Euro 3 (D3)</b>	4 Cyl.		2287cc	<b>85kW (116)PS</b>			<b>TD17145</b>	<b>583</b>
<b>F1AE0481C</b>	4 Cyl.	18.5:1	2286cc	<b>81kW (110)PS</b>	<b>Turbo Intercooled</b>		<b>TD16407</b>	<b>580</b>

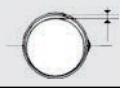
			
<b>87-138000-00</b> STD	<b>08-138000-00</b> STD		
<b>87-138006-00</b> 0.40mm	<b>08-138006-00</b> 0.40mm		
<b>87-138008-00</b> 0.60mm	<b>08-138008-00</b> 0.60mm		
A 57.00	2.50  CK P		
B- 18.18	2.00  P		
BØ 38.00	2.50  CR P		
D 84.00			
 31x67			
<b>AK RT TP</b>			

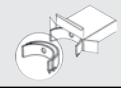
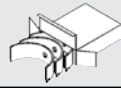
**1229**  **88.00** **Diesel**

									
BE/PL	4	59.015/59.038	62.833/62.848	23.750	1.884	0.027/0.065	BS	71-4080	<b>71-4080/4</b> STD 0.25 0.50 <b>H1020/5</b> STD 0.25 0.50
MB/HL 1-4	4	71.182/71.208	75.588/75.614	27.000	2.174	0.032/0.084	AL-LF	02-4083	
MB/HL 1,2,4	3	71.182/71.208	75.588/75.614	27.000	2.174	0.032/0.084	AL-LF	02-4084	
MB/HL 3	1	71.182/71.208	75.588/75.614	27.000	2.174	0.032/0.084	AL-LF	02-4085H	
MB/HL 5	1	76.182/76.208	80.588/80.614	27.000	2.174	0.032/0.084	AL-LF	02-4086L	
MB/HL 5	1	76.182/76.208	80.588/80.614	27.000	2.174	0.032/0.084	AL-LF	02-4086U	

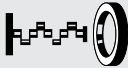
		
---	---	---

**JH5077**  
(Elastomer)



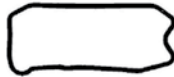



**NA5202**  50.0x80.0x14.0mm, FPM



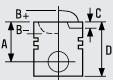
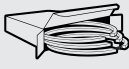





JH5077

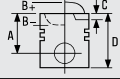
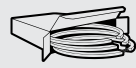

**1230**  **88.00** **Diesel** 

<b>F1AE0481F Euro 4 (D4)</b>	4 Cyl.		2287cc	<b>70kW (95)PS</b>	<b>Turbo Intercooled</b>	<b>TD28231</b>	<b>587</b>
<b>F1AE0481G Euro 4 (D4)</b>	4 Cyl.		2287cc	<b>85kW (116)PS</b>	<b>Turbo Intercooled</b>	<b>TD28232</b>	<b>587</b>
<b>F1AE0481H Euro 4 (D4)</b>	4 Cyl.		2287cc	<b>85kW (116)PS</b>	<b>Turbo Intercooled</b>	<b>TD28233</b>	<b>587</b>
<b>F1AE0481R Euro 4 (D4)</b>	4 Cyl.		2287cc	<b>85kW (116)PS</b>	<b>Turbo Intercooled</b>	<b>TD28234</b>	<b>590</b>
<b>F1AE0481T</b>	4 Cyl.	19:1	2286cc	<b>93kW (126)PS</b>	<b>Turbo Intercooled</b>	<b>TD24632</b>	<b>581</b>

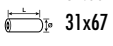



			
	<b>08-138000-00</b> STD <b>08-138006-00</b> 0.40mm <b>08-138008-00</b> 0.60mm  2.50  CK P 2.00  P 2.50  CR P		





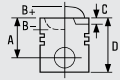
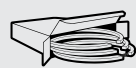

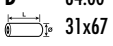
<b>1231</b>	 <b>88.00</b>	<b>Diesel</b>	
<b>FI AE 0481 C</b>	4 Cyl.	2287cc	<b>81kW (110)PS</b>
			<b>Turbo Intercooled</b>
			<b>FM9055 584</b>

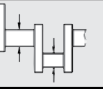
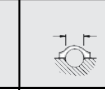
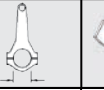

			
<b>87-138000-00</b> STD <b>87-138006-00</b> 0.40mm <b>87-138008-00</b> 0.60mm	<b>08-138000-00</b> STD <b>08-138006-00</b> 0.40mm <b>08-138008-00</b> 0.60mm		
<b>A</b> 57.00 <b>B-</b> 18.18 <b>BØ</b> 38.00 <b>D</b> 84.00  31x67	 2.50 CK P 2.00 P 2.50 CR P		
<b>AK RT TP</b>			

<b>1232</b>	 <b>88.00</b>	<b>Diesel</b>	
-------------	--	---------------	---

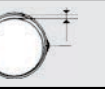
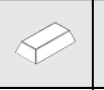
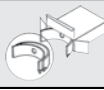
<b>FI AE0481D Euro 4 (D4)</b>	4 Cyl.	19:1	2287cc	<b>88kW (120)PS</b>	<b>Turbo Intercooled</b>	<b>TD20264</b>	<b>585</b>
<b>FI AE0481FA Euro 4 (D4)</b>	4 Cyl.		2287cc	<b>70-78kW (95-106)PS</b>	<b>Turbo Intercooled</b>	<b>TD19231</b>	<b>586</b>
<b>FI AE0481GA Euro 4 (D4)</b>	4 Cyl.		2287cc	<b>85-93kW (116-126)PS</b>	<b>Turbo Intercooled</b>	<b>TD19232</b>	<b>586</b>
<b>FI AE0481HA Euro 4 (D4)</b>	4 Cyl.		2287cc	<b>100kW (136)PS</b>	<b>Turbo Intercooled</b>	<b>TD19233</b>	<b>586</b>
<b>FI AE0481M</b>	4 Cyl.		2287cc	<b>100kW (136)PS</b>	<b>Turbo Intercooled</b>	<b>TD19156</b>	<b>588</b>

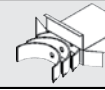
			
<b>87-138000-10</b> STD <b>87-138006-10</b> 0.40mm <b>87-138008-10</b> 0.60mm	<b>08-138000-00</b> STD <b>08-138006-00</b> 0.40mm <b>08-138008-00</b> 0.60mm		
<b>A</b> 57.00 <b>B-</b> 13.75 <b>BØ</b> 50.10 <b>D</b> 84.00  31x67	 2.50 CK P 2.00 P 2.50 CR P		
<b>AK KK RT TP</b>			

											
BE/PL	4	59.015/59.038	62.833/62.848	23.750	1.884	0.027/0.065	BS	71-4080			
MB/HL 1-4	4	71.182/71.208	75.588/75.614	27.000	2.174	0.032/0.084	AL-LF	02-4083			<b>71-4080/4</b> STD 0.25 0.50
MB/HL 1,2,4	3	71.182/71.208	75.588/75.614	27.000	2.174	0.032/0.084	AL-LF	02-4084			<b>H1020/5</b> STD 0.25 0.50
MB/HL 3	1	71.182/71.208	75.588/75.614	27.000	2.174	0.032/0.084	AL-LF	02-4085H			
MB/HL 5	1	76.182/76.208	80.588/80.614	27.000	2.174	0.032/0.084	AL-LF	02-4086L			
MB/HL 5	1	76.182/76.208	80.588/80.614	27.000	2.174	0.032/0.084	AL-LF	02-4086U			

		
---	---	---

**JH5077**  
(Elastomer)

**NA5202**  50.0x80.0x14.0mm, FPM



**JH5077**

# FIAT GROUP

## 1233

 88.00

**Diesel**



**F1AE0481N** 4 Cyl. 19:1 2287cc **96kW (131)PS** Turbo Intercooled **TD24778** **589**

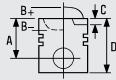

**08-138000-00** STD  
**08-138006-00** 0.40mm  
**08-138008-00** 0.60mm

2.50  CK P  
 2.00  P  
 2.50  CR P



**JH5077**  
 (Elastomer)

**NA5202**  50.0x80.0x14.0mm, FPM



**JH5077**

## 1234

 88.00

**Diesel**









**F1AE0481U Euro 4 (D4)** 4 Cyl. 2287cc **78kW (106)PS** Turbo Intercooled **TD26638** **587**

**F1AE0481V Euro 4 (D4)** 4 Cyl. 2287cc **93kW (126)PS** Turbo Intercooled **TD26637** **587**

**F1AE3481A Euro 5** 4 Cyl. 2287cc **78kW (106)PS** Turbo Intercooled **TD26934** **587**

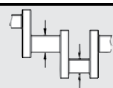
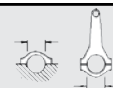
**F1AE3481B Euro 5** 4 Cyl. 2287cc **93kW (126)PS** Turbo Intercooled **TD26935** **587**

**F1AE3481C Euro 5** 4 Cyl. 2287cc **107kW (146)PS** Turbo Intercooled **TD26943** **587**

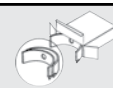
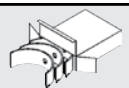
									
BE/PL	4	59.015/59.038	62.833/62.848	23.750	1.884	0.027/0.065	BS	71-4080	<b>71-4080/4</b> STD 0.25 0.50
MB/HL 1-4	4	71.182/71.208	75.588/75.614	27.000	2.174	0.032/0.084	AL-LF	02-4083	<b>H1020/5</b> STD 0.25 0.50
MB/HL 1,2,4	3	71.182/71.208	75.588/75.614	27.000	2.174	0.032/0.084	AL-LF	02-4084	
MB/HL 3	1	71.182/71.208	75.588/75.614	27.000	2.174	0.032/0.084	AL-LF	02-4085H	
MB/HL 5	1	76.182/76.208	80.588/80.614	27.000	2.174	0.032/0.084	AL-LF	02-4086L	
MB/HL 5	1	76.182/76.208	80.588/80.614	27.000	2.174	0.032/0.084	AL-LF	02-4086U	

## 1235

 88.00

**Diesel**



**F1AE3481D** 4 Cyl. 16.2:1 2287cc **96kW (131)PS** Turbo Intercooled **TD25174** **591**

**F1AE3481E** 4 Cyl. 16.2:1 2287cc **109kW (148)PS** Turbo Intercooled **TD25175** **589**





**JH5077**  
 (Elastomer)









**NA5202**  50.0x80.0x14.0mm, FPM

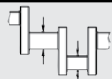

**JH5077**

**1236**  **88.00** **Diesel** 

**FlAE3481G** 4 Cyl. 16.2:1 2287cc **83kW (113)PS** **Turbo Intercooled** **TD26313** **589**

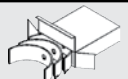
									
BE/PL	4	59.015/59.038	62.833/62.848	23.750	1.884	0.027/0.065	BS	71-4080	<b>71-4080/4</b> STD 0.25 0.50
MB/HL 1-4	4	71.182/71.208	75.588/75.614	27.000	2.174	0.032/0.084	AL-LF	02-4083	<b>H1020/5</b> STD 0.25 0.50
MB/HL 1,2,4	3	71.182/71.208	75.588/75.614	27.000	2.174	0.032/0.084	AL-LF	02-4084	
MB/HL 3	1	71.182/71.208	75.588/75.614	27.000	2.174	0.032/0.084	AL-LF	02-4085H	
MB/HL 5	1	76.182/76.208	80.588/80.614	27.000	2.174	0.032/0.084	AL-LF	02-4086L	
MB/HL 5	1	76.182/76.208	80.588/80.614	27.000	2.174	0.032/0.084	AL-LF	02-4086U	

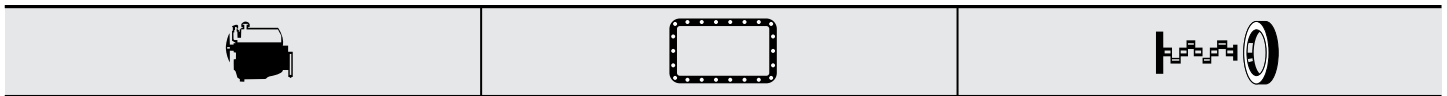



**JH5077**  
(Elastomer)

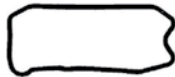







**NA5202**  50.0x80.0x14.0mm, FPM

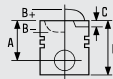

**JH5077**

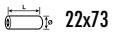
**1237**  **88.00** **Petrol** 

**834 G.000** 6 Cyl. 2492cc **119kW (162)PS** **TD1066** **592**

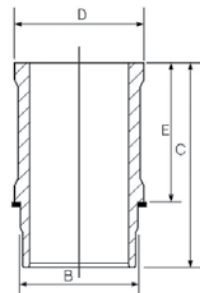







			
<b>87-110500-30</b> STD	<b>08-110500-00</b> STD	<b>15-632300-00</b> [9] B 94.00 C 120.50 D 104.00 E 78.00	<b>89-110500-30</b> 87-110500-30 + 15-632300-00
A 34.35 B+ 4.65 D 68.00  22x73	1.50  CR P 1.75  P 4.00  CR [15]		

[9] Includes seals  
[15] Steel

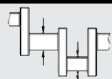
[9] Inclut des joints  
[15] Acier

[9] Comprende le guarnizioni  
[15] Acciaio

[9] Incluye los sellos  
[15] Acero

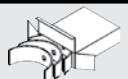
									
BE/PL	6	51.980/52.000	55.511/55.524	19.100	1.749	0.020/0.071	BS	4080CP	<b>71-4218/6</b> STD 0.25
MB/HL 1-4	4	59.951/59.971	63.657/63.676	22.350	1.841	0.020/0.068	BS	4081CP	<b>H1082/4</b> STD 0.25
SE/PB	1	21.994/22.000	25.120/25.146	23.720			BS	60014X	<b>55-4280</b> SEMI

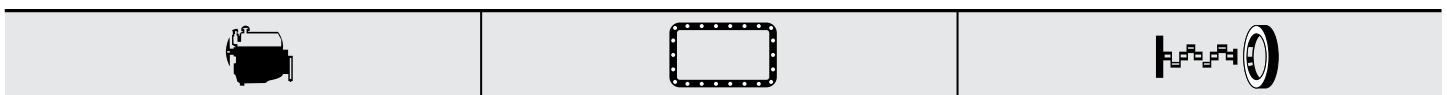

**NA5163**  32.00x47.00x10.00mm, FPM

## 1238



88.00

Petrol



AR 01646	6 Cyl.	9:1	2492cc	110-116kW (150-158)PS	TD36	593
AR 01911	6 Cyl.	9:1	2492cc	110-115kW (150-156)PS	TD42	595
AR 01928	6 Cyl.		2492cc	110-117kW (150-159)PS	TD44	596

<b>87-110500-30</b> STD <b>A</b> 34.35 <b>B+</b> 4.65 <b>D</b> 68.00 22x73	<b>08-110500-00</b> STD 1.50  CR P 1.75  P 4.00  CR [15]	<b>15-632300-00</b> [9] <b>B</b> 94.00 <b>C</b> 120.50 <b>D</b> 104.00 <b>E</b> 78.00 	<b>89-110500-30</b> 87-110500-30 + 15-632300-00

[9] Includes seals [9] Inclut des joints [9] Comprende le guarnizioni [9] Incluye los sellos  
 [15] Steel [15] Acier [15] Acciaio [15] Acero

BE/PL	6	51.980/52.000	55.511/55.524	19.100	1.749	0.020/0.071	BS	4080CP	<b>71-4218/6</b> STD 0.25
MB/HL 1-4	4	59.951/59.971	63.657/63.676	22.350	1.841	0.020/0.068	BS	4081CP	<b>H1082/4</b> STD 0.25
SE/PB	1	21.994/22.000	25.120/25.146	23.720			BS	60014X	<b>55-4280</b> SEMI

## 1239



88.00

Petrol



AR 01648	6 Cyl.		2492cc	113kW (154)PS	TD10150	594
----------	--------	--	--------	---------------	---------	-----







<b>87-110500-30</b> STD <b>A</b> 34.35 <b>B+</b> 4.65 <b>D</b> 68.00 22x73	<b>08-110500-00</b> STD 1.50  CR P 1.75  P 4.00  CR [15]	<b>15-632300-00</b> [9] <b>B</b> 94.00 <b>C</b> 120.50 <b>D</b> 104.00 <b>E</b> 78.00 	<b>89-110500-30</b> 87-110500-30 + 15-632300-00









[9] Includes seals [9] Inclut des joints [9] Comprende le guarnizioni [9] Incluye los sellos  
 [15] Steel [15] Acier [15] Acciaio [15] Acero



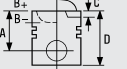
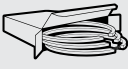



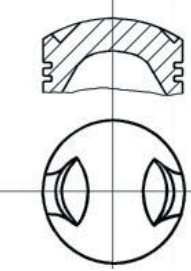

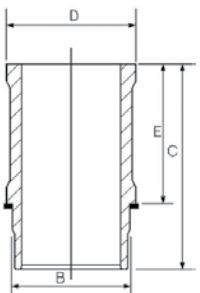

BE/PL	6	51.980/52.000	55.511/55.524	19.100	1.749	0.020/0.071	BS	4080CP	<b>71-4218/6</b> STD 0.25
MB/HL 1-4	4	59.951/59.971	63.657/63.676	22.350	1.841	0.020/0.068	BS	4081CP	<b>H1082/4</b> STD 0.25
SE/PB	1	21.994/22.000	25.120/25.146	23.720			BS	60014X	<b>55-4280</b> SEMI

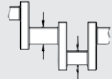







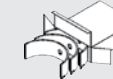

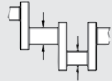
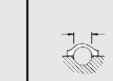
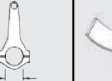

...Continued

<b>1239</b>	 <b>88.00</b>	<b>Petrol</b>
		
	<b>KV086</b>	<b>NA5163</b>  32.00x47.00x10.00mm, FPM
		
<b>KV086</b>		

<b>1240</b>	 <b>88.00</b>	<b>Petrol</b>			
<b>AR 01913</b>	6 Cyl.	9:1	2492cc	<b>116-118kW (158-160)PS</b>	<b>TD43</b>
					
<b>87-110500-30</b>	<b>STD</b>	<b>08-110500-00</b>	<b>STD</b>	<b>15-632300-00</b> [9] B 94.00 C 120.50 D 104.00 E 78.00	<b>89-110500-30</b> 87-110500-30 + 15-632300-00
A 34.35 B+ 4.65 D 68.00  22x73		1.50 1.75 4.00  CR P P CR [15]			
[9] Includes seals [15] Steel	[9] Inclut des joints [15] Acier	[9] Comprende le guarnizioni [15] Acciaio	[9] Incluye los sellos [15] Acero		

										
BE/PL	6	51.980/52.000	55.511/55.524	19.100	1.749	0.020/0.071	BS	4080CP		<b>71-4218/6</b> STD 0.25
MB/HL 1-4	4	59.951/59.971	63.657/63.676	22.350	1.841	0.020/0.068	BS	4081CP		<b>H1082/4</b> STD 0.25

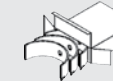
<b>1241</b>	 <b>88.00</b>	<b>Petrol</b>								
<b>AR 11900</b>	6 Cyl.	9:1	2492cc	<b>115kW (156)PS</b>	<b>TD23343</b>					
<b>AR 32402</b>	6 Cyl.		2492cc	<b>140-141kW (191-192)PS</b>	<b>TD19056</b>					
<b>AR 66201</b>	6 Cyl.		2492cc	<b>120kW (163)PS</b>	<b>TD132 600</b>					
										
BE/PL	6	51.980/52.000	55.511/55.524	19.100	1.749	0.020/0.071	BS	4080CP		<b>71-4218/6</b> STD 0.25
MB/HL 1-4	4	59.951/59.971	63.657/63.676	22.350	1.841	0.020/0.068	BS	4081CP		<b>H1082/4</b> STD 0.25
SE/PB	1	21.994/22.000	25.120/25.146	23.720			BS	60014X		<b>55-4280</b> SEMI

# FIAT GROUP

## 1242

88.00

Petrol



AR 32401	6 Cyl.	7.3:1	2492cc	140kW (190)PS	TD9464	597
AR 32405	6 Cyl.		2492cc	141kW (192)PS	TD15634	598
AR 34201	6 Cyl.	10.3:1	2492cc	140kW (190)PS	TD11601	597
AR 36201	6 Cyl.		2492cc	138kW (188)PS	TD15635	599

	<b>08-124600-00</b> STD		
	1.20  CR P		
	1.50  P		
	3.50  P		

BE/PL	6	51.980/52.000	55.511/55.524	19.100	1.749	0.020/0.071	BS	4080CP	<b>71-4218/6</b> STD 0.25
MB/HL 1-4	4	59.951/59.971	63.657/63.676	22.350	1.841	0.020/0.068	BS	4081CP	<b>H1082/4</b> STD 0.25
SE/PB	1	21.994/22.000	25.120/25.146	23.720			BS	60014X	<b>55-4280</b> SEMI

## 1243

88.00

Petrol



AR 67301	6 Cyl.		2492cc	121kW (165)PS	TD139	601
AR 67302	6 Cyl.		2492cc	120kW (163)PS	TD9468	602
AR 67303	6 Cyl.		2492cc	120kW (163)PS	TD9767	603

<b>87-110500-30</b> STD	<b>08-110500-00</b> STD	<b>15-632300-00</b> [9] B 94.00 C 120.50 D 104.00 E 78.00	<b>89-110500-30</b> 87-110500-30 + 15-632300-00
A 34.35 B+ 4.65 D 68.00 22x73	1.50  CR P 1.75  P 4.00  CR [15]		

[9] Includes seals

[9] Inclut des joints

[9] Comprende le guarnizioni

[9] Incluye los sellos

[15] Steel



[15] Acier









[15] Acciaio

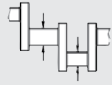
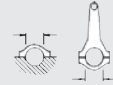

[15] Acero





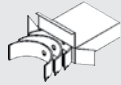

BE/PL	6	51.980/52.000	55.511/55.524	19.100	1.749	0.020/0.071	BS	4080CP	<b>71-4218/6</b> STD 0.25
MB/HL 1-4	4	59.951/59.971	63.657/63.676	22.350	1.841	0.020/0.068	BS	4081CP	<b>H1082/4</b> STD 0.25
SE/PB	1	21.994/22.000	25.120/25.146	23.720			BS	60014X	<b>55-4280</b> SEMI



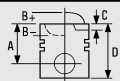
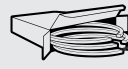



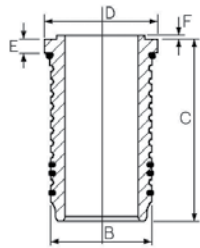

	HR397	NJ951  32.00x50.00x8.00mm, FPM

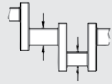
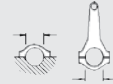

<b>1244</b>	 <b>91.00</b>	<b>Petrol</b>			
<b>834 A.000</b>	6 Cyl.	9.5:1	2849cc	<b>110kW (150)PS</b>	<b>TD18863</b>
<b>834 E.000</b>	6 Cyl.		2849cc	<b>110kW (150)PS</b>	<b>TD4623</b>
<b>834 E.146</b>	6 Cyl.		2849cc	<b>108kW (147)PS</b>	<b>TD4609</b>





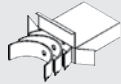

									
MB/HL 1-4	4	70.043/70.062	74.000/74.019	23.470	1.967	0.020/0.067	AL-LF	66311RA	<b>H1041/4</b> STD

<b>1245</b>	 <b>92.00</b>	<b>Diesel</b>					
<b>VM 81 A</b>	4 Cyl.	22:1	2393cc	<b>81kW (110)PS</b>	<b>Turbocharged</b>	<b>TD152</b>	<b>607</b>
<b>VM 82 A</b>	3 Cyl.	22:1	1779cc	<b>54kW (73)PS</b>	<b>Turbocharged</b>	<b>TD153</b>	<b>605</b>
<b>VM 96 A</b>	3 Cyl.	22:1	1779cc	<b>62kW (84)PS</b>	<b>Turbocharged</b>	<b>TD155</b>	<b>605</b>

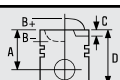
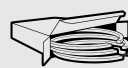
			
	<b>08-110100-00</b> STD	<b>14-676420-00 WH</b> B 101.50 C 166.80 D 110.00 E 8.90 F 1.20	
	2.50  CR P		
	2.00  P		
	4.00  CR P		

									
BE/PL	1	53.940/53.955	57.563/57.582	23.250	1.798	0.020/0.071	BS	66655CP	<b>71-4234</b> STD 0.25 0.50 0.75
TW/A	2	74.250/74.500	88.000/88.100		2.362		AL-LF	61588AF	<b>A227/2</b> STD
SE/PB	1	29.990/29.996	34.000/34.025	30.120			BS	66659XA	<b>55-4235</b> SEMI

<b>1246</b>	 <b>92.00</b>	<b>Diesel</b>					
<b>VM4HT 2.4</b>	4 Cyl.		2393cc	<b>69-70kW (94-95)PS</b>	<b>Turbocharged</b>	<b>TD159</b>	<b>606</b>

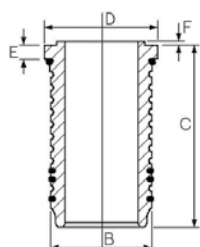
			
	<b>08-110100-00</b> STD	<b>14-676420-00 WH</b> B 101.50 C 166.80 D 110.00 E 8.90 F 1.20	
	2.50  CR P		
	2.00  P		
	4.00  CR P		

# FIAT GROUP

...Continued

1246		92.00	Diesel						
BE/PL	1	53.940/53.955	57.563/57.582	23.250	1.798	0.020/0.071	BS	66655CP	71-4234 STD 0.25 0.50 0.75
TW/A	2	74.250/74.500	88.000/88.100		2.362		AL-LF	61588AF	A227/2 STD
SE/PB	1	29.990/29.996	34.000/34.025	30.120			BS	66659XA	55-4235 SEMI

	JJ452 (MVQ) KV086	
	JJ452	KV086

1247		92.00	Diesel						
THY (DK5ATE)		4 Cyl.	22:1	2446cc	96kW (131)PS	Turbo Intercooled	TD22239		
BE/PL	4	53.981/54.000	57.675/57.695	22.700	1.823	0.030/0.090	SP	71-3951	71-3951/4 STD [21]

1248		92.00	Diesel						
VM 07 B	4 Cyl.	22:1	2499cc	92kW (125)PS	Turbocharged	TD149	608		
VM 08 B	4 Cyl.	22:1	2499cc	92kW (125)PS	Turbocharged	TD9771	609		
VM 31 B	4 Cyl.	22:1	2499cc	92-125kW (125-170)PS	Turbocharged	TD9768	609		
VM 32 B	4 Cyl.	22:1	2499cc	92kW (125)PS	Turbocharged	TD127	610		
VM 84 A	4 Cyl.	22:1	2499cc	84kW (114)PS	Turbocharged	TD154	611		

87-110100-00 STD		08-110100-00 STD	14-676420-00 WH B 101.50 C 166.80 D 110.00 E 8.90 F 1.20
A 51.00 B- 2.10 D 86.00 30x76		2.50 CR P 2.00 P 4.00 CR P	

...Continued

1248		92.00	Diesel							
BE/PL	1	53.940/53.955	57.563/57.582	23.250	1.798	0.020/0.071	BS	66655CP	71-4234 STD 0.25 0.50 0.75	
TW/A	2	74.250/74.500	88.000/88.100		2.362		AL-LF	61588AF	A227/2 STD	
SE/PB	1	29.990/29.996	34.000/34.025	30.120			BS	66659XA	55-4235 SEMI	

1249		92.00	Diesel							
VM-425 CHIEA 08 B	4 Cyl.	21.5:1	2499cc	90kW (122)PS	Turbo Intercooled			TD156		
VM-425 SLIRA	4 Cyl.	21.5:1	2500cc	86kW (118)PS	Turbo Intercooled			TD157		

BE/PL	1	53.940/53.955	57.563/57.582	23.250	1.798	0.020/0.071	BS	66655CP	71-4234 STD 0.25 0.50 0.75
TW/A	2	74.250/74.500	88.000/88.100		2.362		AL-LF	61588AF	A227/2 STD
SE/PB	1	29.990/29.996	34.000/34.025	30.120			BS	66659XA	55-4235 SEMI

1250		93.00	Diesel							
8144.61	4 Cyl.	21:1	2428cc	53-55kW (72-75)PS				TD4408	612	

87-214500-00 87-214508-00	STD 0.60mm		08-214500-10 08-214508-10	STD 0.60mm	14-021280-00 DH [11] B 97.03 C 167.00 D 100.00 E 5.00 14-022560-00 D B 96.00 C 167.30 D 98.90 E 5.00		
A 54.80 B- 2.20 D 89.80 32x75			06/81 → 3.00  CR P 2.00  P 4.00  CR P				
HA RT			08-214400-10 01/78 → 05/81	STD			
			2.00  CR P 2.00  P 4.00  CR P				

[11] Nitrided

[11] Nitridé









[11] Nitruato

[11] Nitruado

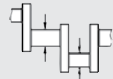
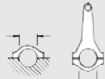
**1250**

 **93.00**

**Diesel**

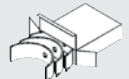
									
BE/PL	4	56.520/56.535	60.333/60.345	24.700	1.870	0.020/0.072	BS	1870CP	<b>71-4130/4</b> STD 0.25 0.50 0.75
BE/PL	4	56.520/56.535	60.333/60.345	24.700	1.870	0.020/0.070	BS	66575CP	<b>71-4185/4</b> STD 0.25 0.50 0.75

**1870CP**

**66575CP**

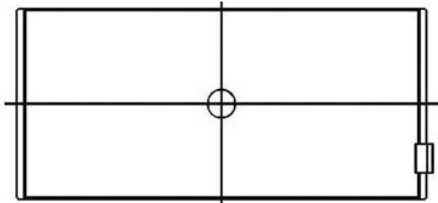
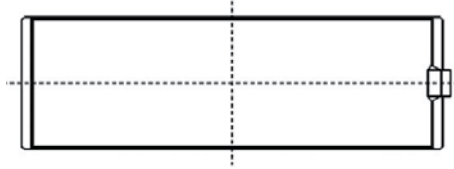

MB/HL 1-4	4	76.187/76.200	80.586/80.607	24.990	2.172	0.042/0.100	BS	66571CP	<b>H1049/5</b> STD 0.25 0.50 0.75
MB/HL 5	1	76.187/76.200	80.586/80.607	31.950	2.172	0.042/0.100	BS	66572CPH	
MB/HL 1-4	4	76.187/76.200	80.586/80.607	24.990	2.172	0.038/0.097	BS	66573CP	<b>H1094/5</b> STD 0.25
MB/HL 5	1	76.187/76.200	80.586/80.607	31.950	2.172	0.038/0.097	BS	66574CPH	

**66571CP**

**66572CPH**

**66573CP**

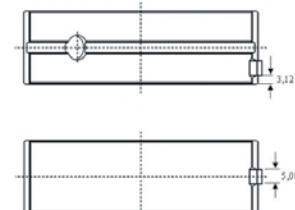
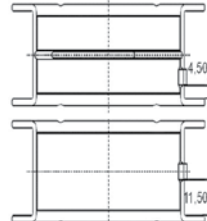
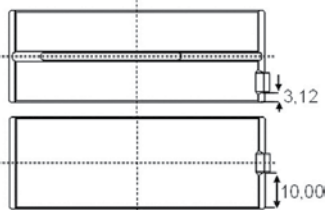



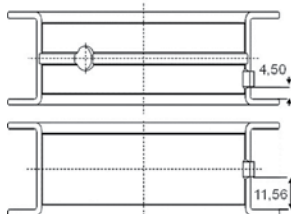

**66574CPH**

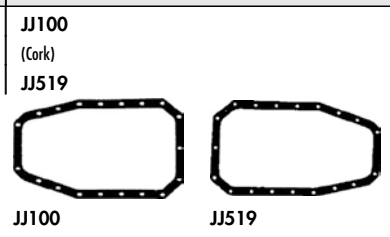







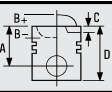
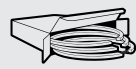

SE/PB	1	31.990/31.996	34.895/34.920	30.700			BS	66579YA	<b>55-4186</b> SEMI
-------	---	---------------	---------------	--------	--	--	----	---------	------------------------

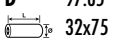
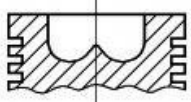
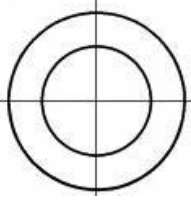



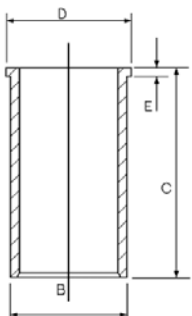

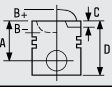
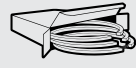

**NB946**  70.00x90.00x10.00mm, FPM  
**NF833**  90.00x115.00x13.00mm, FPM

<b>1251</b>	 <b>93.00</b>	<b>Diesel</b>	
<b>8140.21</b>	4 Cyl.	18:1	2445cc
<b>8140.21.201-203</b>	4 Cyl.		2445cc
			<b>68kW (92)PS</b>
			<b>Turbocharged</b>
			<b>FM9103 613</b>
			<b>FM9240</b>

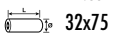
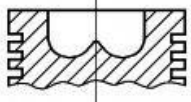
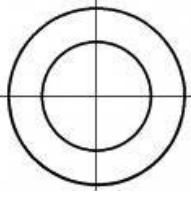
			
<p><b>87-245200-30</b> <b>87-245208-30</b></p> <p>STD 0.60mm</p> <p><b>A</b> 59.65 <b>B-</b> 14.80 <b>BØ</b> 51.90 <b>D</b> 97.65  32x75</p> <p><b>RT</b></p>	 	<p><b>08-245200-00</b> STD <b>08-245208-00</b> 0.60mm</p> <p>3.00  CR P 2.00  P 3.00  CR P</p>	<p><b>14-021371-00 D</b> <b>B</b> 96.01 <b>C</b> 171.00 <b>D</b> 98.92 <b>E</b> 5.00 <b>14-021372-00 D</b> <b>B</b> 96.05 <b>C</b> 171.00 <b>D</b> 98.92 <b>E</b> 5.00 <b>14-021373-00 D</b> <b>B</b> 96.17 <b>C</b> 171.00 <b>D</b> 98.92 <b>E</b> 5.00 <b>14-021480-00 DH [11]</b> <b>B</b> 97.04 <b>C</b> 171.00 <b>D</b> 100.00 <b>E</b> 5.00</p> 
[11] Nitrided	[11] Nitridé	[11] Nitrurato	[11] Nitrurado



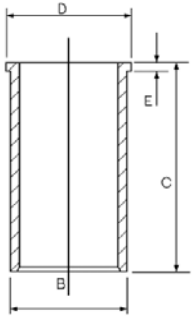





<b>1252</b>	 <b>93.00</b>	<b>Diesel</b>	
<b>8140.21.200</b>	4 Cyl.	18:1	2445cc
			<b>68kW (92)PS</b>
			<b>Turbocharged</b>
			<b>TD1703 614</b>

			
<p><b>87-245200-30</b> <b>87-245208-30</b></p> <p>STD 0.60mm</p> <p><b>A</b> 59.65 <b>B-</b> 14.80 <b>BØ</b> 51.90 <b>D</b> 97.65  32x75</p> <p><b>RT</b></p>	 	<p><b>08-245200-00</b> STD <b>08-245208-00</b> 0.60mm</p> <p>3.00  CR P 2.00  P 3.00  CR P</p>	<p><b>14-021371-00 D</b> <b>B</b> 96.01 <b>C</b> 171.00 <b>D</b> 98.92 <b>E</b> 5.00 <b>14-021372-00 D</b> <b>B</b> 96.05 <b>C</b> 171.00 <b>D</b> 98.92 <b>E</b> 5.00 <b>14-021373-00 D</b> <b>B</b> 96.17 <b>C</b> 171.00 <b>D</b> 98.92 <b>E</b> 5.00 <b>14-021480-00 DH [11]</b> <b>B</b> 97.04 <b>C</b> 171.00 <b>D</b> 100.00 <b>E</b> 5.00</p> 
[11] Nitrided	[11] Nitridé	[11] Nitrurato	[11] Nitrurado

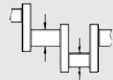
**1252**

 **93.00**

**Diesel**

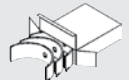
									
BE/PL	4	56.520/56.535	60.333/60.345	24.700	1.870	0.020/0.070	BS	66575CP	<b>71-4185/4</b> STD 0.25 0.50 0.75
MB/HL 1-4	4	76.187/76.200	80.586/80.607	24.990	2.172	0.042/0.100	BS	66571CP	<b>H1049/5</b> STD 0.25 0.50 0.75
MB/HL 5	1	76.187/76.200	80.586/80.607	31.950	2.172	0.042/0.100	BS	66572CPH	

**Mot. → 1846776**

MB/HL 1-4	4	76.187/76.200	80.586/80.607	24.990	2.172	0.038/0.097	BS	66573CP	<b>H1094/5</b> STD 0.25
MB/HL 5	1	76.187/76.200	80.586/80.607	31.950	2.172	0.038/0.097	BS	66574CPH	

**Mot. 1846777 →**

**66571CP**

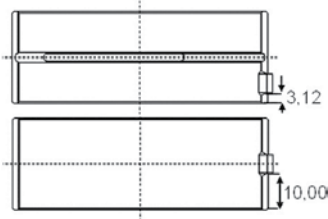

**66572CPH**

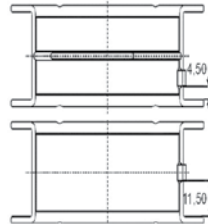

**66573CP**

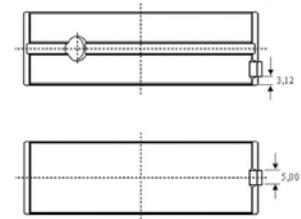

**66574CPH**

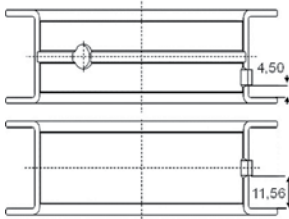





SE/PB	1	31.990/31.996	34.895/34.920	30.700			BS	66579YA	<b>55-4186</b> SEMI
-------	---	---------------	---------------	--------	--	--	----	---------	------------------------



 **ES381**

**JH5178**  
Soft Material Gasket  
**JJ519**

**NF853**  100.00x118.00x10.00mm, FPM  
**NP067**  50.00x70.00x10.00mm, FPM  
**NF883**  114.00x177.00x13.00mm, FPM  
**NF885**  70.00x179.00x16.00mm, FPM  
**NF886**  100.00x179.00x15.80mm, FPM



**JH5178**

**JJ519**



## 1253

### 93.00

### Diesel



8140.21.200 D.I.	4 Cyl.	18:1	2445cc	68kW (92)PS	Turbocharged	TD143	615
8144.21.220	4 Cyl.	18:1	2445cc	68kW (92)PS	Turbocharged	TD145	625

<b>87-245200-30</b> <b>87-245208-30</b>  STD 0.60mm  A 59.65 B- 14.80 BØ 51.90 D 97.65 32x75  RT	<b>08-245200-00</b> <b>08-245208-00</b>  STD 0.60mm  3.00  CR P 2.00  P 3.00  CR P	<b>14-021371-00 D</b> B 96.01 C 171.00 D 98.92 E 5.00 <b>14-021372-00 D</b> B 96.05 C 171.00 D 98.92 E 5.00 <b>14-021373-00 D</b> B 96.17 C 171.00 D 98.92 E 5.00 <b>14-021480-00 DH [11]</b> B 97.04 C 171.00 D 100.00 E 5.00  	

[11] Nitrided

[11] Nitridé

[11] Nitratato

[11] Niturado

BE/PL	4	56.520/56.535	60.333/60.345	24.700	1.870	0.020/0.072	BS	1870CP	<b>71-4130/4</b> STD 0.25 0.50 0.75	
BE/PL	4	56.520/56.535	60.333/60.345	24.700	1.870	0.020/0.070	BS	66575CP	<b>71-4185/4</b> STD 0.25 0.50 0.75	

1870CP



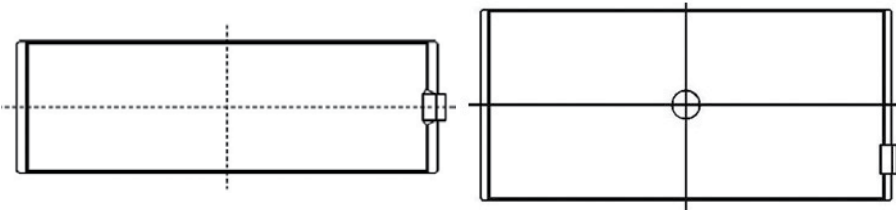





66575CP

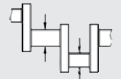
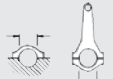

**1253**

 **93.00**

**Diesel**

									
MB/HL 1-4	4	76.187/76.200	80.586/80.607	24.990	2.172	0.042/0.100	BS	66571CP	<b>H1049/5</b> STD 0.25 0.50 0.75
MB/HL 5	1	76.187/76.200	80.586/80.607	31.950	2.172	0.042/0.100	BS	66572CPH	
MB/HL 1-4	4	76.187/76.200	80.586/80.607	24.990	2.172	0.038/0.097	BS	66573CP	<b>H1094/5</b> STD 0.25
MB/HL 5	1	76.187/76.200	80.586/80.607	31.950	2.172	0.038/0.097	BS	66574CPH	

**66571CP**

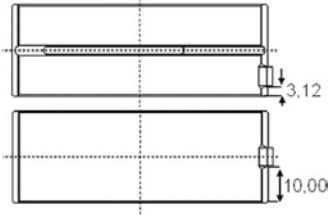

**66572CPH**

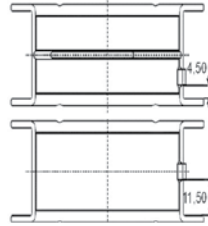

**66573CP**

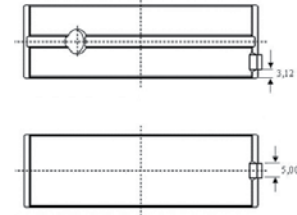

**66574CPH**

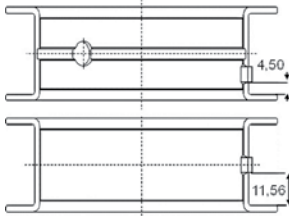

SE/PB	1	31.990/31.996	34.895/34.920	30.700			BS	66579YA	<b>55-4186</b> SEMI
-------	---	---------------	---------------	--------	--	--	----	---------	------------------------



JJ100

(Cork)

JJ519



JJ100

JJ519

NB946  70.00x90.00x10.00mm, FPM









**1254**

 **93.00**

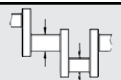
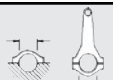
**Diesel**





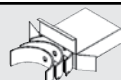





<b>8140.21.201</b>	4 Cyl.	18:1	2445cc	<b>68kW (92)PS</b>	<b>Turbocharged</b>	<b>TD27368</b>	<b>613</b>
<b>8140.21.202</b>	4 Cyl.	18:1	2445cc	<b>68kW (92)PS</b>	<b>Turbocharged</b>	<b>TD27369</b>	<b>613</b>
<b>8140.21.203</b>	4 Cyl.	18:1	2445cc	<b>68kW (92)PS</b>	<b>Turbocharged</b>	<b>TD27370</b>	<b>613</b>
<b>8140.21.212</b>	4 Cyl.	18:1	2445cc	<b>68kW (92)PS</b>	<b>Turbocharged</b>	<b>TD27371</b>	<b>613</b>
<b>8140.21.290</b>	4 Cyl.	18:1	2445cc	<b>68kW (92)PS</b>	<b>Turbocharged</b>	<b>TD27372</b>	<b>613</b>

									
BE/PL	4	56.520/56.535	60.333/60.345	24.700	1.870	0.020/0.072	BS	1870CP	<b>71-4130/4</b> STD 0.25 0.50 0.75

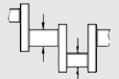
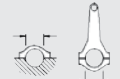
10/02 →

...Continued

**1254**  **93.00 Diesel**

									
BE/PL	4	56.520/56.535	60.333/60.345	24.700	1.870	0.020/0.070	BS	66575CP	71-4185/4 STD 0.25 0.50 0.75

→09/02

1870CP

66575CP

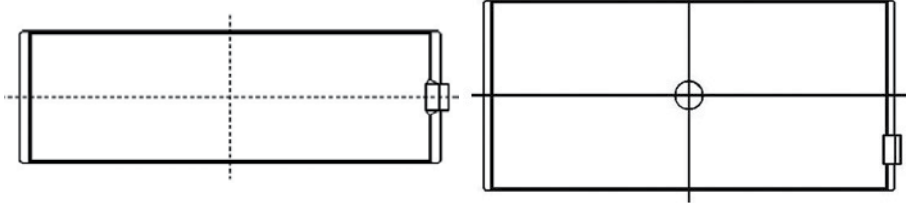

MB/HL 1-4	4	76.187/76.200	80.586/80.607	24.990	2.172	0.042/0.100	BS	66571CP	H1049/5 STD 0.25 0.50 0.75
MB/HL 5	1	76.187/76.200	80.586/80.607	31.950	2.172	0.042/0.100	BS	66572CPH	

Mot. →1846776

MB/HL 1-4	4	76.187/76.200	80.586/80.607	24.990	2.172	0.038/0.097	BS	66573CP	H1094/5 STD 0.25
MB/HL 5	1	76.187/76.200	80.586/80.607	31.950	2.172	0.038/0.097	BS	66574CPH	

Mot.1846777 →

66571CP

66572CPH

66573CP

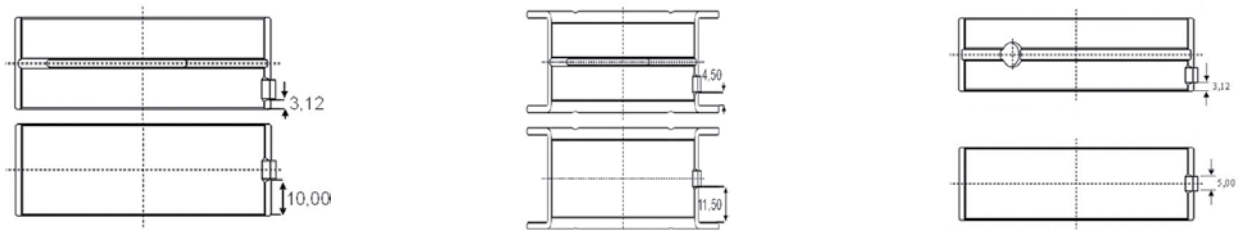

66574CPH

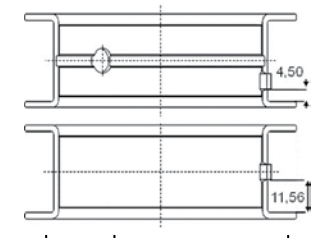

SE/PB	1	31.990/31.996	34.895/34.920	30.700			BS	66579YA	55-4186 SEMI
-------	---	---------------	---------------	--------	--	--	----	---------	-----------------

## 1255

93.00

**Diesel**



8140.21.214

4 Cyl.

18:1

2445cc

77kW (105)PS

Turbocharged

TD1704

616

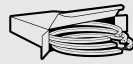
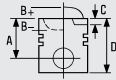

87-245200-30  
87-245208-30

STD  
0.60mm

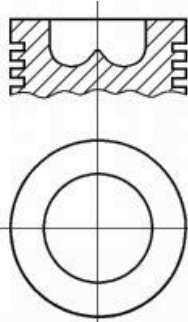

08-245200-00 STD  
08-245208-00 0.60mm

3.00 CR P  
2.00 P  
3.00 CR P



14-021371-00 D  
B 96.01 C 171.00 D 98.92 E 5.00  
14-021372-00 D  
B 96.05 C 171.00 D 98.92 E 5.00  
14-021373-00 D  
B 96.17 C 171.00 D 98.92 E 5.00  
14-021480-00 DH [11]  
B 97.04 C 171.00 D 100.00 E 5.00

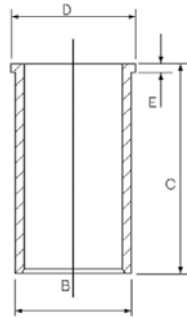

A 59.65  
B- 14.80  
BØ 51.90  
D 97.65  
32x75

RT

[11] Nitrided [11] Nitridé [11] Nitrurato [11] Nitrurado

BE/PL	4	56.520/56.535	60.333/60.345	24.700	1.870	0.020/0.072	BS	1870CP	71-4130/4 STD 0.25 0.50 0.75

10/02→

BE/PL	4	56.520/56.535	60.333/60.345	24.700	1.870	0.020/0.070	BS	66575CP	71-4185/4 STD 0.25 0.50 0.75
-------	---	---------------	---------------	--------	-------	-------------	----	---------	---------------------------------

→09/82

1870CP

66575CP

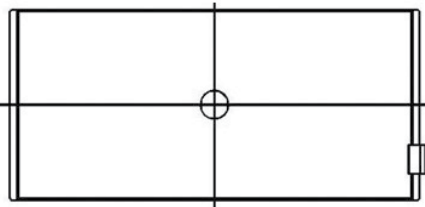
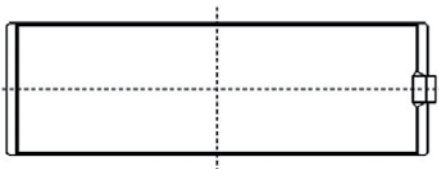







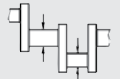
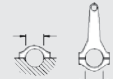

MB/HL 1-4	4	76.187/76.200	80.586/80.607	24.990	2.172	0.042/0.100	BS	66571CP	H1049/5 STD 0.25 0.50 0.75
MB/HL 5	1	76.187/76.200	80.586/80.607	31.950	2.172	0.042/0.100	BS	66572CPH	

Mot.→1846776

...Continued

**1255**  **93.00 Diesel**

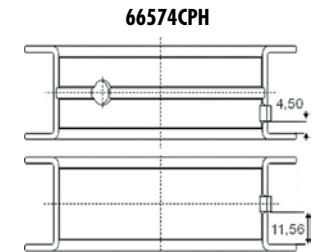
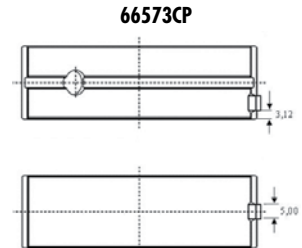
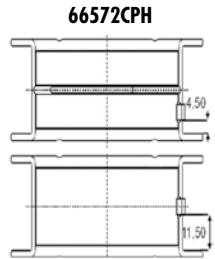
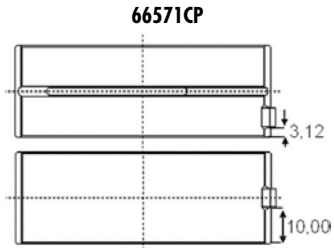

									
MB/HL 1-4	4	76.187/76.200	80.586/80.607	24.990	2.172	0.038/0.097	BS	66573CP	<b>H1094/5</b> STD 0.25
MB/HL 5	1	76.187/76.200	80.586/80.607	31.950	2.172	0.038/0.097	BS	66574CPH	

Mot.1846777 →





SE/PB	1	31.990/31.996	34.895/34.920	30.700		BS	66579YA	<b>55-4186</b> SEMI
-------	---	---------------	---------------	--------	--	----	---------	------------------------

09/82 →, Mot.344183 →

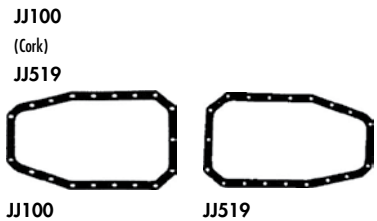
		
---	---	---



**NF853**  100.00x118.00x10.00mm, FPM  
**NP067**  50.00x70.00x10.00mm, FPM

## 1256

 93.00

**Diesel**



8140.27.210, 8140.27.213

4 Cyl.

18:1

2445cc

77kW (105)PS

Turbocharged

FM9131

613

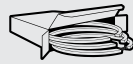
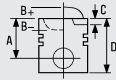

87-245200-60

STD

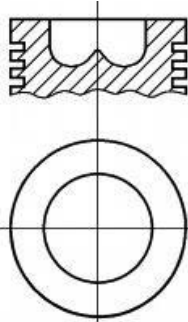

08-245200-00

STD

08-245208-00

0.60mm

3.00



CR P

2.00



P

3.00



CR P

14-021371-00 D

B 96.01 C 171.00 D 98.92 E 5.00

14-021372-00 D

B 96.05 C 171.00 D 98.92 E 5.00

14-021373-00 D

B 96.17 C 171.00 D 98.92 E 5.00

14-021480-00 DH [11]

B 97.04 C 171.00 D 100.00 E 5.00

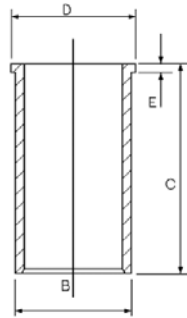

A 58.65

B- 14.80

BØ 51.90

D 75.20

 32x75

RT

[11] Nitrided

[11] Nitridé

[11] Niturato

[11] Niturado

## 1257

 93.00

**Diesel**



8140.27.218

4 Cyl.

18:1

2445cc

77kW (105)PS

Turbocharged

FM19131

613

8140.27R.2700, 8140.27S.2700,

4 Cyl.

18:1

2499cc

Turbocharged

FM9102

644

8140.27.2700, 8140.27R, 8140.27S

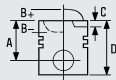

87-245200-40

STD

87-245208-40

0.60mm

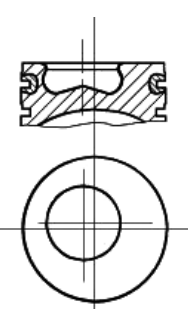

A 58.75

B- 17.90

BØ 38.00

D 96.75

 32x75

RT

87-245200-50

STD

87-245208-50

0.60mm

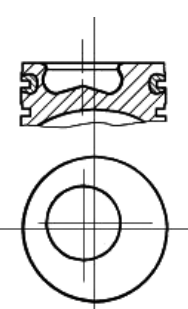

A 58.75

B- 17.90

BØ 38.00

D 96.75

 32x78

AK NB RT

## 1258

93.00

**Diesel**



8140.27 S

4 Cyl.

18:1

2445cc

68kW (92)PS

Turbocharged

TD1705

617

BE/PL	4	56.520/56.535	60.333/60.345	24.700	1.870	0.020/0.072	BS	1870CP	<b>71-4130/4</b> STD 0.25 0.50 0.75
BE/PL	4	56.520/56.535	60.333/60.345	24.700	1.870	0.020/0.070	BS	66575CP	<b>71-4185/4</b> STD 0.25 0.50 0.75

**1870CP**

**66575CP**

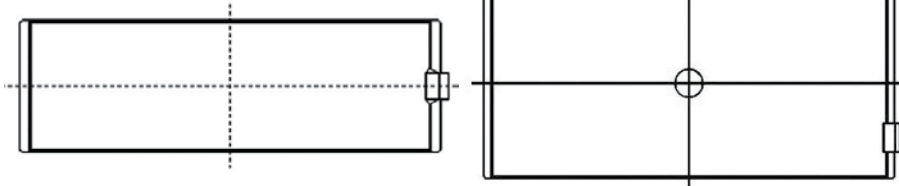

MB/HL 1-4	4	76.187/76.200	80.586/80.607	24.990	2.172	0.042/0.100	BS	66571CP	<b>H1049/5</b> STD 0.25 0.50 0.75
MB/HL 5	1	76.187/76.200	80.586/80.607	31.950	2.172	0.042/0.100	BS	66572CPH	
MB/HL 1-4	4	76.187/76.200	80.586/80.607	24.990	2.172	0.038/0.097	BS	66573CP	<b>H1094/5</b> STD 0.25
MB/HL 5	1	76.187/76.200	80.586/80.607	31.950	2.172	0.038/0.097	BS	66574CPH	

**66571CP**

**66572CPH**

**66573CP**

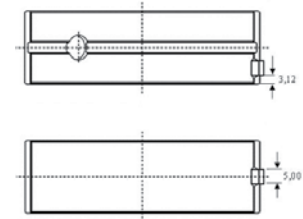
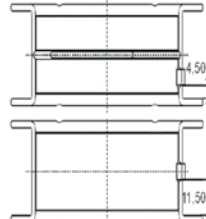
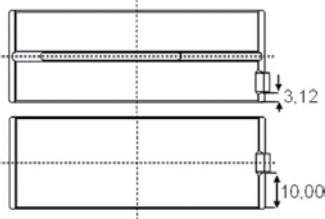

**66574CPH**

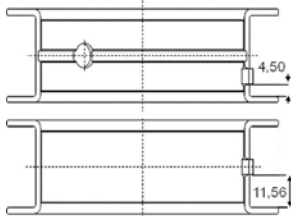

SE/PB	1	31.990/31.996	34.895/34.920	30.700			BS	66579YA	<b>55-4186</b> SEMI
-------	---	---------------	---------------	--------	--	--	----	---------	------------------------



ES381

**JH5178**  
Soft Material Gasket  
**JJ519**

**NF833** 90.00x115.00x13.00mm, FPM



**JH5178**

**JJ519**









## 1259

 93.00

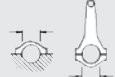
**Diesel**



8140.47.3700	4 Cyl.	18.5:1	2499cc	85kW (116)PS	Turbo Intercooled	TD6809	655
8140.61.204	4 Cyl.	21:1	2445cc	53kW (72)PS		TD1051	621
8144.81.2000	4 Cyl.	22:1	2445cc	66-74kW (90-101)PS		TD1057	632

									
BE/PL	4	56.520/56.535	60.333/60.345	24.700	1.870	0.020/0.072	BS	1870CP	<b>71-4130/4</b> STD 0.25 0.50 0.75
BE/PL	4	56.520/56.535	60.333/60.345	24.700	1.870	0.020/0.070	BS	66575CP	<b>71-4185/4</b> STD 0.25 0.50 0.75

1870CP

66575CP

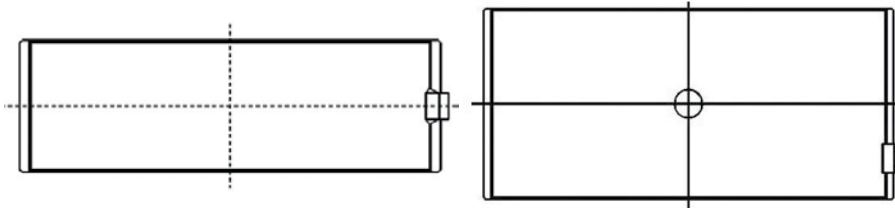

MB/HL 1-4	4	76.187/76.200	80.586/80.607	24.990	2.172	0.042/0.100	BS	66571CP	<b>H1049/5</b> STD 0.25 0.50 0.75
MB/HL 5	1	76.187/76.200	80.586/80.607	31.950	2.172	0.042/0.100	BS	66572CPH	
MB/HL 1-4	4	76.187/76.200	80.586/80.607	24.990	2.172	0.038/0.097	BS	66573CP	<b>H1094/5</b> STD 0.25
MB/HL 5	1	76.187/76.200	80.586/80.607	31.950	2.172	0.038/0.097	BS	66574CPH	

66571CP

66572CPH

66573CP

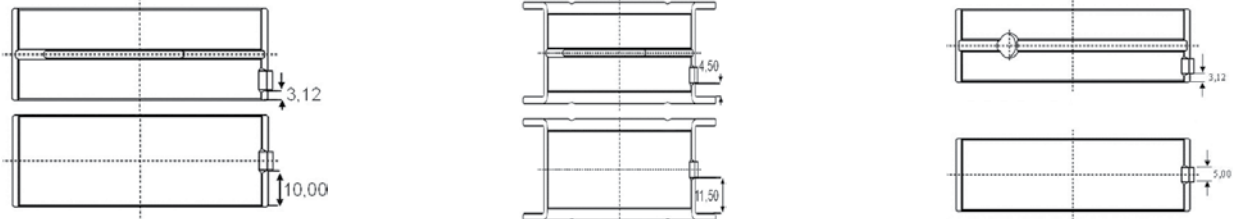

66574CPH

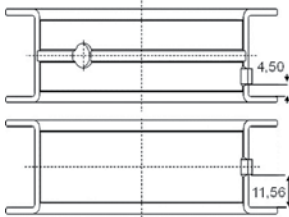

SE/PB	1	31.990/31.996	34.895/34.920	30.700			BS	66579YA	<b>55-4186</b> SEMI
-------	---	---------------	---------------	--------	--	--	----	---------	------------------------



JJ519

NB946 70.00x90.00x10.00mm, FPM



JJ519



## 1260

### 93.00

### Diesel



8140.61

4 Cyl.

21:1

2445cc

53-55kW (72-75)PS

TD1050

618

<b>87-214500-00</b> <b>87-214508-00</b>  <b>A</b> 54.80 <b>B-</b> 2.20 <b>D</b> 89.80 32x75  <b>HA RT</b>	STD 0.60mm  	<b>08-214500-10</b> STD <b>08-214508-10</b> 0.60mm 06/81 →  3.00  CR P 2.00  P 4.00  CR P	<b>14-021280-00 DH [11]</b> <b>B</b> 97.03 <b>C</b> 167.00 <b>D</b> 100.00 <b>E</b> 5.00 <b>14-022560-00 D</b> <b>B</b> 96.00 <b>C</b> 167.30 <b>D</b> 98.90 <b>E</b> 5.00  				
		<b>08-214400-10</b> STD 01/78 → 05/81  2.00  CR P 2.00  P 4.00  CR P					

[11] Nitrided

[11] Nitridé

[11] Nitruato

[11] Niturado

BE/PL	4	56.520/56.535	60.333/60.345	24.700	1.870	0.020/0.072	BS	1870CP	<b>71-4130/4</b> STD 0.25 0.50 0.75
BE/PL	4	56.520/56.535	60.333/60.345	24.700	1.870	0.020/0.070	BS	66575CP	<b>71-4185/4</b> STD 0.25 0.50 0.75

1870CP

66575CP

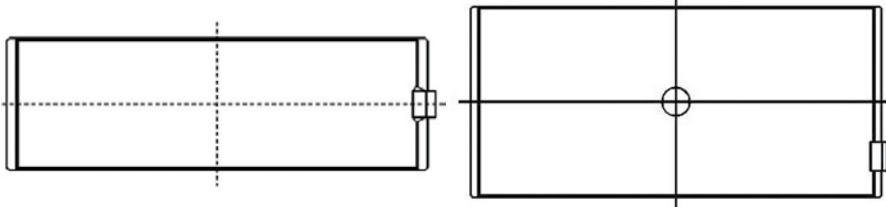

**1260**

**93.00**

**Diesel**

MB/HL 1-4	4	76.187/76.200	80.586/80.607	24.990	2.172	0.042/0.100	BS	66571CP	<b>H1049/5</b> STD 0.25 0.50 0.75
MB/HL 5	1	76.187/76.200	80.586/80.607	31.950	2.172	0.042/0.100	BS	66572CPH	
MB/HL 1-4	4	76.187/76.200	80.586/80.607	24.990	2.172	0.038/0.097	BS	66573CP	<b>H1094/5</b> STD 0.25
MB/HL 5	1	76.187/76.200	80.586/80.607	31.950	2.172	0.038/0.097	BS	66574CPH	

**66571CP**

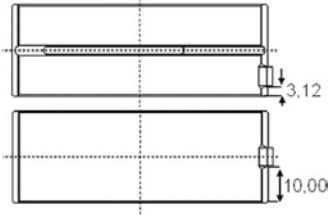

**66572CPH**

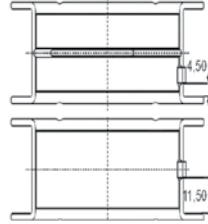

**66573CP**

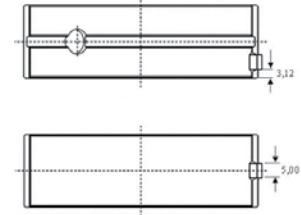

**66574CPH**

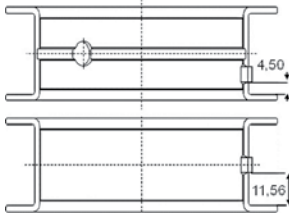

SE/PB	1	31.990/31.996	34.895/34.920	30.700		BS	66579YA	<b>55-4186</b> SEMI
-------	---	---------------	---------------	--------	--	----	---------	------------------------



**JH5077**

(Elastomer)

**LS856**

**NB946** 70.00x90.00x10.00mm, FPM

**NF833** 90.00x115.00x13.00mm, FPM



**JH5077**

**LS856**









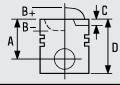

## 1261

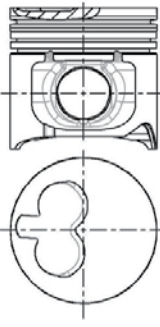
 93.00

**Diesel**

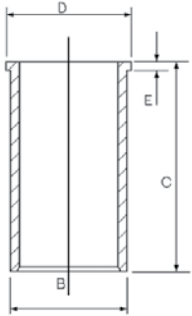

8140.61.200	4 Cyl.	21:1	2445cc	53kW (72)PS	TD144	619
8144.61.200	4 Cyl.	22:1	2445cc	53kW (72)PS	TD146	630

 <p><b>87-214500-00</b> STD <b>87-214508-00</b> 0.60mm</p> <p>A 54.80 B- 2.20 D 89.80  32x75</p> <p>HA RT</p> 	 <p><b>08-214500-10</b> STD <b>08-214508-10</b> 0.60mm</p> <p>3.00  CR P 2.00  P 4.00  CR P</p>	 <p><b>14-021280-00 DH [11]</b> B 97.03 C 167.00 D 100.00 E 5.00 <b>14-022560-00 D</b> B 96.00 C 167.30 D 98.90 E 5.00</p> 	
--	---	--	---

[11] Nitrided      [11] Nitridé      [11] Nitrurato      [11] Nitrurado

									
BE/PL	4	56.520/56.535	60.333/60.345	24.700	1.870	0.020/0.072	BS	1870CP	<b>71-4130/4</b> STD 0.25 0.50 0.75
BE/PL	4	56.520/56.535	60.333/60.345	24.700	1.870	0.020/0.070	BS	66575CP	<b>71-4185/4</b> STD 0.25 0.50 0.75

1870CP

66575CP

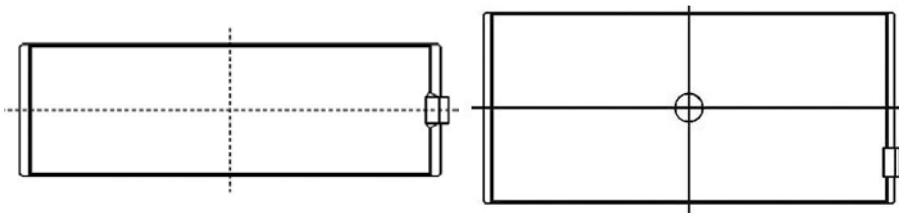

**1261**

**93.00**

**Diesel**

MB/HL 1-4	4	76.187/76.200	80.586/80.607	24.990	2.172	0.042/0.100	BS	66571CP	<b>H1049/5</b> STD 0.25 0.50 0.75
MB/HL 5	1	76.187/76.200	80.586/80.607	31.950	2.172	0.042/0.100	BS	66572CPH	
MB/HL 1-4	4	76.187/76.200	80.586/80.607	24.990	2.172	0.038/0.097	BS	66573CP	<b>H1094/5</b> STD 0.25
MB/HL 5	1	76.187/76.200	80.586/80.607	31.950	2.172	0.038/0.097	BS	66574CPH	

**66571CP**

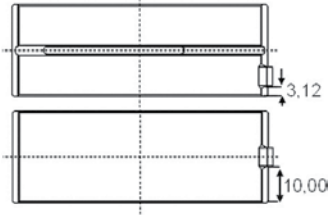

**66572CPH**

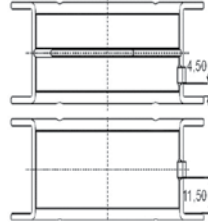

**66573CP**

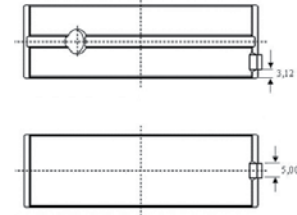

**66574CPH**

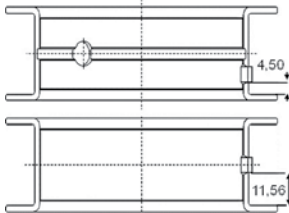

SE/PB	1	31.990/31.996	34.895/34.920	30.700		BS	66579YA	<b>55-4186</b> SEMI
-------	---	---------------	---------------	--------	--	----	---------	------------------------



JJ100

(Cork)

JJ519



JJ100

JJ519

NF833 90.00x115.00x13.00mm, FPM

## 1262

### 93.00

### Diesel



8140.61.200

4 Cyl.

21:1

2445cc

53kW (72)PS

TD7225

620

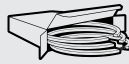
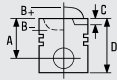

87-214500-00  
87-214508-00

STD  
0.60mm

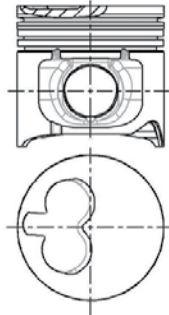

A 54.80  
B- 2.20  
D 89.80  
32x75

HA RT

08-214500-10 STD  
08-214508-10 0.60mm  
06/81 →

3.00 CR P  
2.00 P  
4.00 CR P

08-214400-10 STD  
01/78 → 05/81

2.00 CR P  
2.00 P  
4.00 CR P

14-021280-00 DH [11]  
B 97.03 C 167.00 D 100.00 E 5.00  
14-022560-00 D  
B 96.00 C 167.30 D 98.90 E 5.00  
14-028930-00 D  
B 97.50 C 167.00 D 100.90 E 5.00  
14-028931-00 D  
B 97.58 C 167.00 D 100.90 E 5.00  
14-028932-00 D  
B 97.70 C 167.00 D 100.90 E 5.00

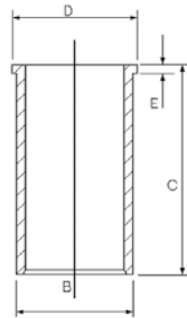

[11] Nitrided

[11] Nitridé

[11] Niturato

[11] Niturado

BE/PL	4	56.520/56.535	60.333/60.345	24.700	1.870	0.020/0.072	BS	1870CP	71-4130/4 STD 0.25 0.50 0.75
BE/PL	4	56.520/56.535	60.333/60.345	24.700	1.870	0.020/0.070	BS	66575CP	71-4185/4 STD 0.25 0.50 0.75

1870CP



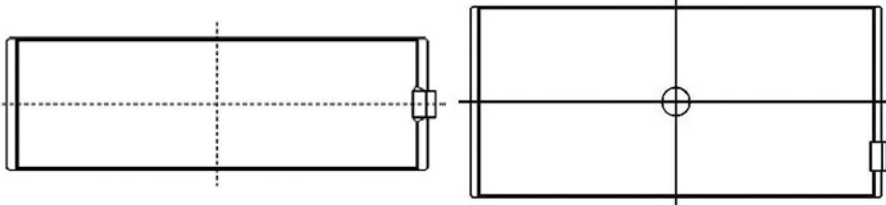







66575CP

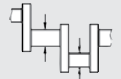

**1262**

 **93.00**

**Diesel**

									
MB/HL 1-4	4	76.187/76.200	80.586/80.607	24.990	2.172	0.042/0.100	BS	66571CP	<b>H1049/5</b> STD 0.25 0.50 0.75
MB/HL 5	1	76.187/76.200	80.586/80.607	31.950	2.172	0.042/0.100	BS	66572CPH	
MB/HL 1-4	4	76.187/76.200	80.586/80.607	24.990	2.172	0.038/0.097	BS	66573CP	<b>H1094/5</b> STD 0.25
MB/HL 5	1	76.187/76.200	80.586/80.607	31.950	2.172	0.038/0.097	BS	66574CPH	

**66571CP**

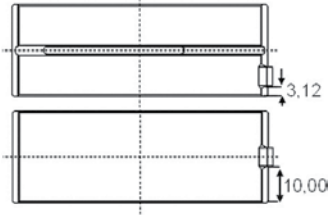

**66572CPH**

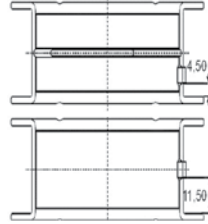

**66573CP**

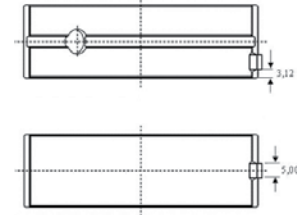

**66574CPH**

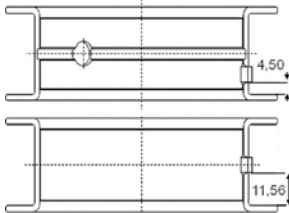



SE/PB	1	31.990/31.996	34.895/34.920	30.700			BS	66579YA	<b>55-4186</b> SEMI
-------	---	---------------	---------------	--------	--	--	----	---------	------------------------



**JJ100**  
(Cork)



**JJ100**

**NP067**  50.00x70.00x10.00mm, FPM  
**NF833**  90.00x115.00x13.00mm, FPM

## 1263

 93.00

Diesel



8140.61.300

4 Cyl.









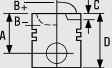
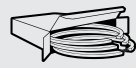

21:1

2445cc

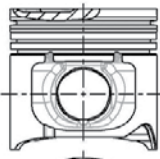
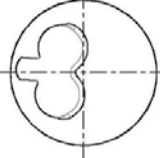
53kW (72)PS

TD20426

622

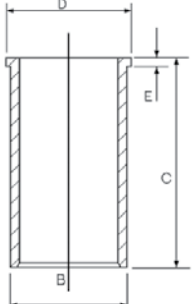







					
<p><b>87-214500-00</b> STD <b>87-214508-00</b> 0.60mm</p> <p>A 54.80 B- 2.20 D 89.80  32x75</p> <p>HA RT</p>	  	<p><b>08-214500-10</b> STD <b>08-214508-10</b> 0.60mm 06/81 →</p> <p>3.00  CR P 2.00  P 4.00  CR P</p>	<p><b>14-021280-00 DH</b> [11] B 97.03 C 167.00 D 100.00 E 5.00 <b>14-022560-00 D</b> B 96.00 C 167.30 D 98.90 E 5.00 <b>14-028930-00 D</b> B 97.50 C 167.00 D 100.90 E 5.00 <b>14-028931-00 D</b> B 97.58 C 167.00 D 100.90 E 5.00 <b>14-028932-00 D</b> B 97.70 C 167.00 D 100.90 E 5.00</p>	<p><b>08-214400-10</b> STD 01/78 → 05/81</p> <p>2.00  CR P 2.00  P 4.00  CR P</p>	

[11] Nitrided

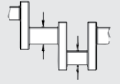
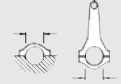
[11] Nitridé

[11] Nitrurato

[11] Nitrurado

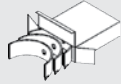
									
BE/PL	4	56.520/56.535	60.333/60.345	24.700	1.870	0.020/0.072	BS	1870CP	<b>71-4130/4</b> STD 0.25 0.50 0.75
<b>10/02 →</b>									
BE/PL	4	56.520/56.535	60.333/60.345	24.700	1.870	0.020/0.070	BS	66575CP	<b>71-4185/4</b> STD 0.25 0.50 0.75
<b>→09/82</b>									

1870CP

66575CP

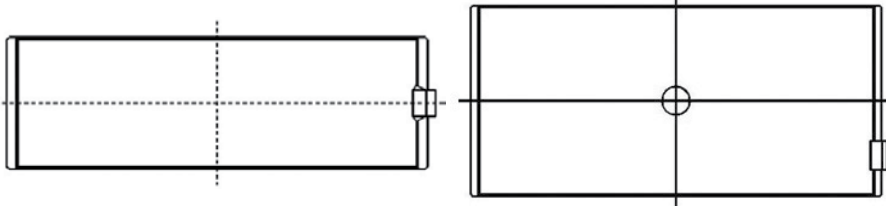

**1263**

 **93.00**

**Diesel**

									
MB/HL 1-4	4	76.187/76.200	80.586/80.607	24.990	2.172	0.042/0.100	BS	66571CP	<b>H1049/5</b> STD 0.25 0.50 0.75
MB/HL 5	1	76.187/76.200	80.586/80.607	31.950	2.172	0.042/0.100	BS	66572CPH	

**Mot. → 1846776**

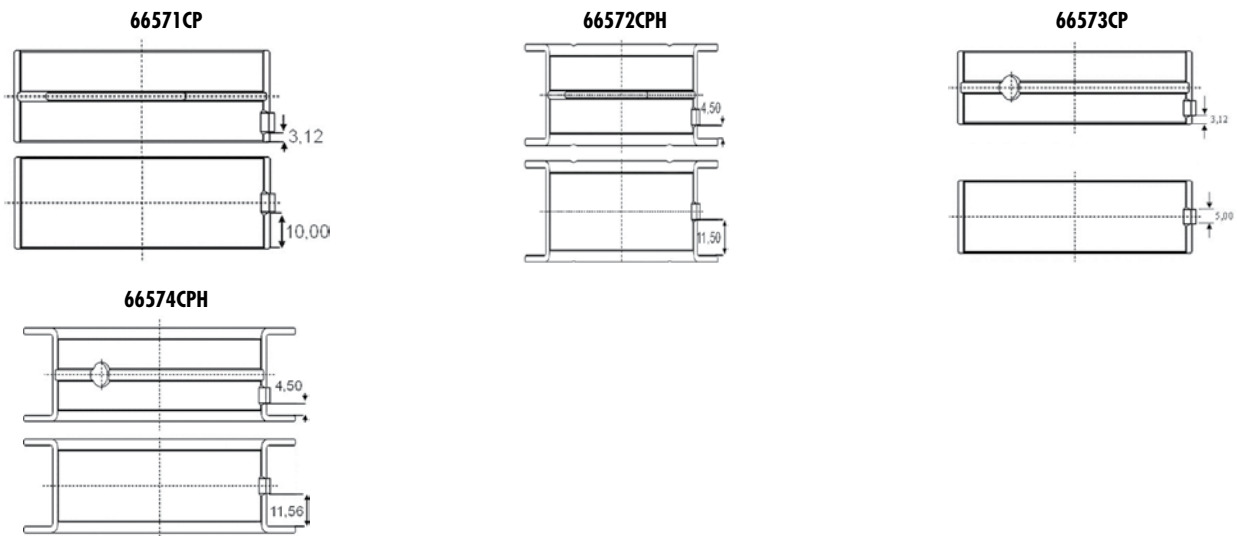

MB/HL 1-4	4	76.187/76.200	80.586/80.607	24.990	2.172	0.038/0.097	BS	66573CP	<b>H1094/5</b> STD 0.25
MB/HL 5	1	76.187/76.200	80.586/80.607	31.950	2.172	0.038/0.097	BS	66574CPH	

**Mot. 1846777 →**



SE/PB	1	31.990/31.996	34.895/34.920	30.700			BS	66579YA	<b>55-4186</b> SEMI
-------	---	---------------	---------------	--------	--	--	----	---------	------------------------



**09/82 →, Mot. 344183 →**

		
---	---	---

**JJ100**  
(Cork)



**JJ100**

**NP067**  50.00x70.00x10.00mm, FPM  
**NF833**  90.00x115.00x13.00mm, FPM



## 1264

93.00

**Diesel**



8142.61

4 Cyl.

21:1

2445cc

53kW (72)PS

TD1053

623

<p><b>87-214500-00</b> <b>87-214508-00</b></p> <p>STD 0.60mm</p> <p>A 54.80 B- 2.20 D 89.80  32x75</p> <p>HA RT</p>		<p><b>08-214500-10</b> STD <b>08-214508-10</b> 0.60mm 06/81 →</p> <p>3.00  CR P 2.00  P 4.00  CR P</p>	<p><b>14-021280-00 DH</b> [11] <b>B 97.03 C 167.00 D 100.00 E 5.00</b> <b>14-022560-00 D</b> <b>B 96.00 C 167.30 D 98.90 E 5.00</b></p>					
		<p><b>08-214400-10</b> STD 01/78 → 05/81</p> <p>2.00  CR P 2.00  P 4.00  CR P</p>						

[11] Nitrided

[11] Nitridé

[11] Nitruato

[11] Niturado

BE/PL	4	56.520/56.535	60.333/60.345	24.700	1.870	0.020/0.072	BS	1870CP	<b>71-4130/4</b> STD 0.25 0.50 0.75
BE/PL	4	56.520/56.535	60.333/60.345	24.700	1.870	0.020/0.070	BS	66575CP	<b>71-4185/4</b> STD 0.25 0.50 0.75

1870CP



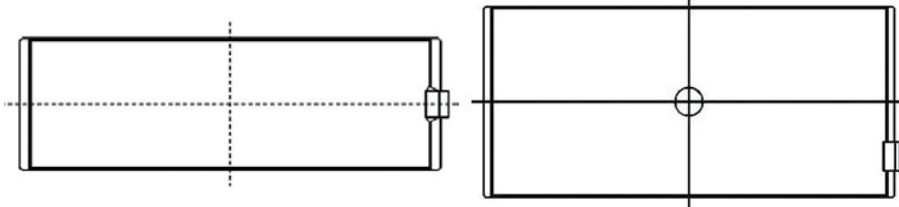







66575CP

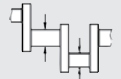

**1264**

 **93.00**

**Diesel**

									
MB/HL 1-4	4	76.187/76.200	80.586/80.607	24.990	2.172	0.042/0.100	BS	66571CP	<b>H1049/5</b> STD 0.25 0.50 0.75
MB/HL 5	1	76.187/76.200	80.586/80.607	31.950	2.172	0.042/0.100	BS	66572CPH	
MB/HL 1-4	4	76.187/76.200	80.586/80.607	24.990	2.172	0.038/0.097	BS	66573CP	<b>H1094/5</b> STD 0.25
MB/HL 5	1	76.187/76.200	80.586/80.607	31.950	2.172	0.038/0.097	BS	66574CPH	

**66571CP**

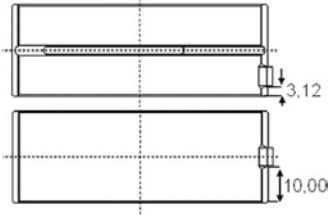

**66572CPH**

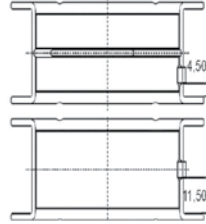

**66573CP**

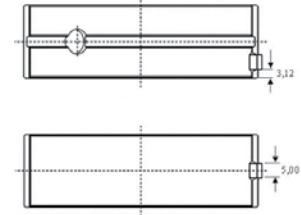

**66574CPH**

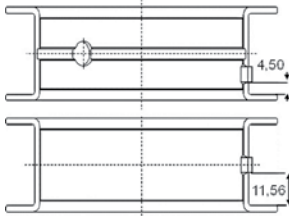

SE/PB	1	31.990/31.996	34.895/34.920	30.700		BS	66579YA	<b>55-4186</b> SEMI
-------	---	---------------	---------------	--------	--	----	---------	------------------------



JJ519



JJ519

**NB946** 70.00x90.00x10.00mm, FPM

## 1265

### 93.00

### Diesel



8144.21      4 Cyl.      18:1      2445cc      68kW (92)PS      Turbocharged      TD4419      624

<p><b>87-245200-30</b> <b>87-245208-30</b></p> <p>STD 0.60mm</p> <p>A 59.65 B- 14.80 BØ 51.90 D 97.65 ③ 32x75</p> <p>RT</p>		<p><b>08-245200-00</b> STD <b>08-245208-00</b> 0.60mm</p> <p>3.00  CR P 2.00  P 3.00  CR P</p>	<p><b>14-021371-00 D</b> B 96.01 C 171.00 D 98.92 E 5.00 <b>14-021372-00 D</b> B 96.05 C 171.00 D 98.92 E 5.00 <b>14-021373-00 D</b> B 96.17 C 171.00 D 98.92 E 5.00 <b>14-021480-00 DH [11]</b> B 97.04 C 171.00 D 100.00 E 5.00</p>	
[11] Nitrided	[11] Nitridé	[11] Nitruato	[11] Nitruado	

BE/PL	4	56.520/56.535	60.333/60.345	24.700	1.870	0.020/0.072	BS	1870CP	<b>71-4130/4</b> STD 0.25 0.50 0.75
BE/PL	4	56.520/56.535	60.333/60.345	24.700	1.870	0.020/0.070	BS	66575CP	<b>71-4185/4</b> STD 0.25 0.50 0.75

1870CP



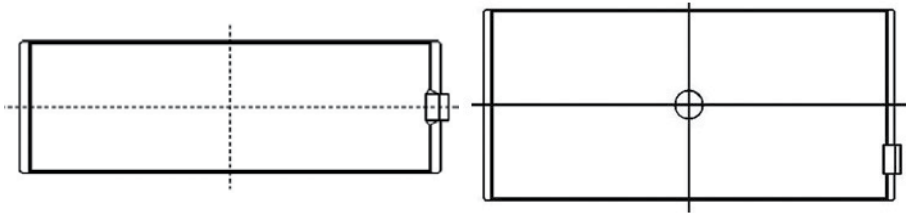







66575CP

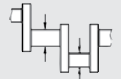

**1265**

 **93.00**

**Diesel**

									
MB/HL 1-4	4	76.187/76.200	80.586/80.607	24.990	2.172	0.042/0.100	BS	66571CP	<b>H1049/5</b> STD 0.25 0.50 0.75
MB/HL 5	1	76.187/76.200	80.586/80.607	31.950	2.172	0.042/0.100	BS	66572CPH	
MB/HL 1-4	4	76.187/76.200	80.586/80.607	24.990	2.172	0.038/0.097	BS	66573CP	<b>H1094/5</b> STD 0.25
MB/HL 5	1	76.187/76.200	80.586/80.607	31.950	2.172	0.038/0.097	BS	66574CPH	

**66571CP**

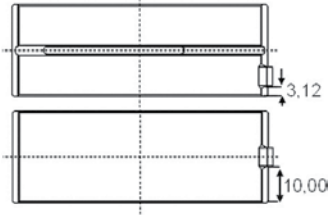

**66572CPH**

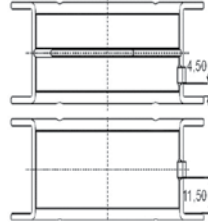

**66573CP**

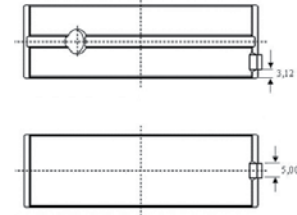

**66574CPH**

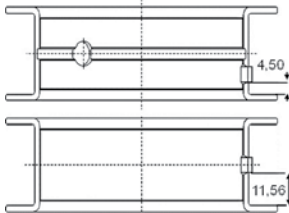



SE/PB	1	31.990/31.996	34.895/34.920	30.700		BS	66579YA	<b>55-4186</b> SEMI
-------	---	---------------	---------------	--------	--	----	---------	------------------------



**JJ100**  
(Cork)



**JJ100**

**NB946**  70.00x90.00x10.00mm, FPM  
**NF833**  90.00x115.00x13.00mm, FPM

## 1266

### 93.00

### Diesel



8144.21.220

4 Cyl.

18:1

2445cc

68kW (92)PS

Turbocharged

TD6803

626

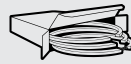
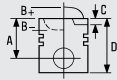

87-245200-30  
87-245208-30

STD  
0.60mm

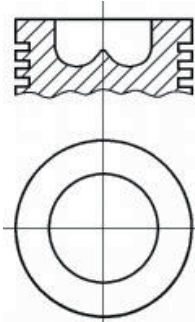

08-245200-00 STD  
08-245208-00 0.60mm



A 59.65  
B- 14.80  
BØ 51.90  
D 97.65  
32x75

RT

14-021371-00 D  
B 96.01 C 171.00 D 98.92 E 5.00  
14-021372-00 D  
B 96.05 C 171.00 D 98.92 E 5.00  
14-021373-00 D  
B 96.17 C 171.00 D 98.92 E 5.00  
14-021480-00 DH [11]  
B 97.04 C 171.00 D 100.00 E 5.00

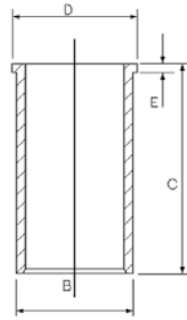

[11] Nitrided

[11] Nitridé

[11] Nitruato

[11] Nitruado

BE/PL	4	56.520/56.535	60.333/60.345	24.700	1.870	0.020/0.072	BS	1870CP	71-4130/4 STD 0.25 0.50 0.75
BE/PL	4	56.520/56.535	60.333/60.345	24.700	1.870	0.020/0.070	BS	66575CP	71-4185/4 STD 0.25 0.50 0.75

1870CP

66575CP

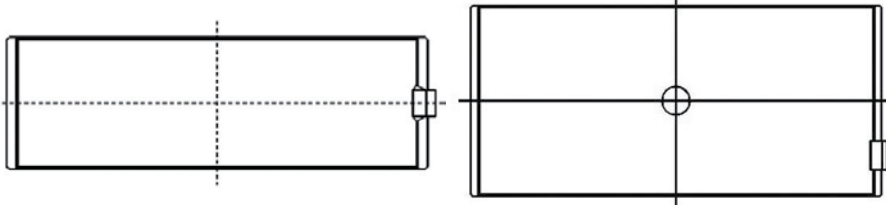

**1266**

**93.00**

**Diesel**

MB/HL 1-4	4	76.187/76.200	80.586/80.607	24.990	2.172	0.042/0.100	BS	66571CP	<b>H1049/5</b> STD 0.25 0.50 0.75
MB/HL 5	1	76.187/76.200	80.586/80.607	31.950	2.172	0.042/0.100	BS	66572CPH	
MB/HL 1-4	4	76.187/76.200	80.586/80.607	24.990	2.172	0.038/0.097	BS	66573CP	<b>H1094/5</b> STD 0.25
MB/HL 5	1	76.187/76.200	80.586/80.607	31.950	2.172	0.038/0.097	BS	66574CPH	

**66571CP**

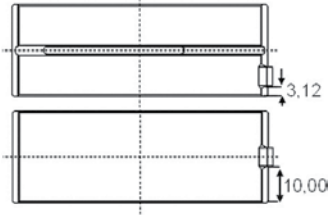

**66572CPH**

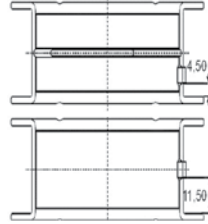

**66573CP**

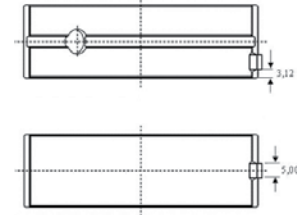

**66574CPH**

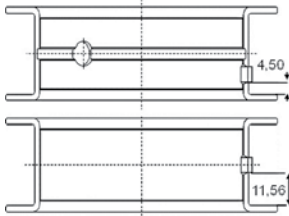

SE/PB	1	31.990/31.996	34.895/34.920	30.700		BS	66579YA	<b>55-4186</b> SEMI
-------	---	---------------	---------------	--------	--	----	---------	------------------------





**JJ100**  
(Cork)









**JJ100**

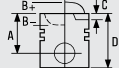
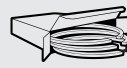

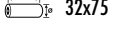
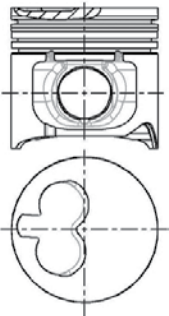
**NP067** 50.00x70.00x10.00mm, FPM  
**NF833** 90.00x115.00x13.00mm, FPM

**1267**  **93.00 Diesel** 

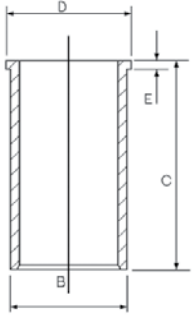





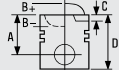
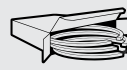

**8144.61** 4 Cyl. 22:1 2445cc **53kW (72)PS** **FM566 627**

			
<p><b>87-214500-00</b> STD <b>87-214508-00</b> 0.60mm</p> <p>A 54.80 B- 2.20 D 89.80  32x75</p> <p>HA RT</p> 	<p><b>08-214500-10</b> STD <b>08-214508-10</b> 0.60mm</p> <p>3.00  CR P 2.00  P 4.00  CR P</p>	<p><b>14-021280-00 DH [11]</b> B 97.03 C 167.00 D 100.00 E 5.00 <b>14-022560-00 D</b> B 96.00 C 167.30 D 98.90 E 5.00</p> 	

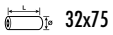
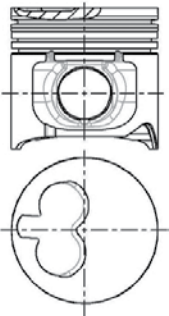





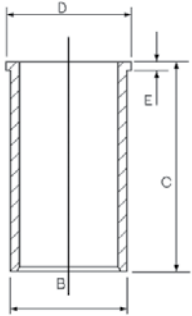



[11] Nitrided [11] Nitridé [11] Niturato [11] Niturado

**1268**  **93.00 Diesel** 

**8144.61.200** 4 Cyl. 22:1 2445cc **53kW (72)PS** **TD6796 628**

			
<p><b>87-214500-00</b> STD <b>87-214508-00</b> 0.60mm</p> <p>A 54.80 B- 2.20 D 89.80  32x75</p> <p>HA RT</p> 	<p><b>08-214500-10</b> STD <b>08-214508-10</b> 0.60mm 06/81 →</p> <p>3.00  CR P 2.00  P 4.00  CR P</p> <hr/> <p><b>08-214400-10</b> STD 01/78 → 05/81</p> <p>2.00  CR P 2.00  P 4.00  CR P</p>	<p><b>14-021280-00 DH [11]</b> B 97.03 C 167.00 D 100.00 E 5.00 <b>14-022560-00 D</b> B 96.00 C 167.30 D 98.90 E 5.00</p> 	

[11] Nitrided [11] Nitridé [11] Niturato [11] Niturado

									
BE/PL	4	56.520/56.535	60.333/60.345	24.700	1.870	0.020/0.072	BS	1870CP	<b>71-4130/4</b> STD 0.25 0.50 0.75
BE/PL	4	56.520/56.535	60.333/60.345	24.700	1.870	0.020/0.070	BS	66575CP	<b>71-4185/4</b> STD 0.25 0.50 0.75

1870CP



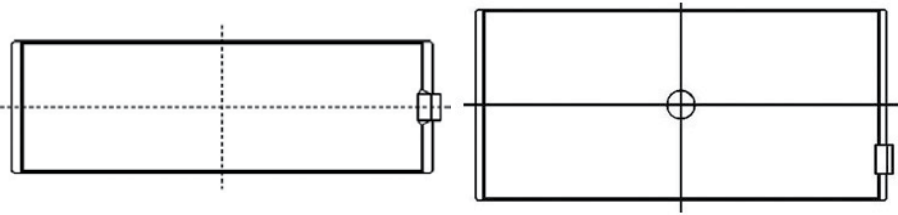







66575CP

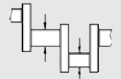

**1268**

 **93.00**

**Diesel**

									
MB/HL 1-4	4	76.187/76.200	80.586/80.607	24.990	2.172	0.042/0.100	BS	66571CP	<b>H1049/5</b> STD 0.25 0.50 0.75
MB/HL 5	1	76.187/76.200	80.586/80.607	31.950	2.172	0.042/0.100	BS	66572CPH	
MB/HL 1-4	4	76.187/76.200	80.586/80.607	24.990	2.172	0.038/0.097	BS	66573CP	<b>H1094/5</b> STD 0.25
MB/HL 5	1	76.187/76.200	80.586/80.607	31.950	2.172	0.038/0.097	BS	66574CPH	

**66571CP**

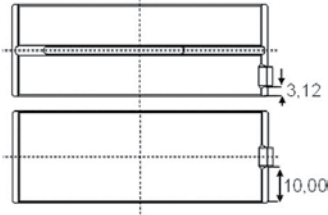

**66572CPH**

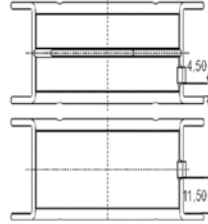

**66573CP**

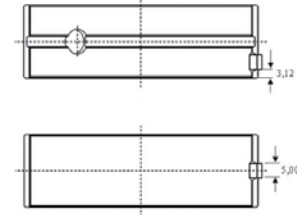

**66574CPH**

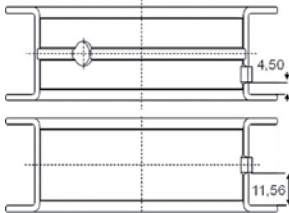

SE/PB	1	31.990/31.996	34.895/34.920	30.700		BS	66579YA	<b>55-4186</b> SEMI
-------	---	---------------	---------------	--------	--	----	---------	------------------------



JJ100  
(Cork)  
JJ519



JJ100

JJ519

**NA5055**  70.00x90.00x10.00mm, FPM



## 1269

 93.00

**Diesel**



8144.61.200

4 Cyl.







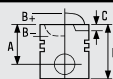
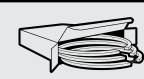

22:1

2445cc

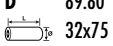
53kW (72)PS

TD20429

629

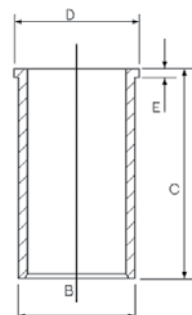





			
<p><b>87-214500-00</b> STD <b>87-214508-00</b> 0.60mm</p> <p>A 54.80 B- 2.20 D 89.80  32x75</p> <p>HA RT</p>	<p><b>08-214500-10</b> STD <b>08-214508-10</b> 0.60mm 06/81 →</p> <p>3.00  CR P 2.00  P 4.00  CR P</p> <hr/> <p><b>08-214400-10</b> STD 01/78 → 05/81</p> <p>2.00  CR P 2.00  P 4.00  CR P</p>	<p><b>14-021280-00 DH</b> [11] B 97.03 C 167.00 D 100.00 E 5.00 <b>14-022560-00 D</b> B 96.00 C 167.30 D 98.90 E 5.00 <b>14-028930-00 D</b> B 97.50 C 167.00 D 100.90 E 5.00 <b>14-028931-00 D</b> B 97.58 C 167.00 D 100.90 E 5.00 <b>14-028932-00 D</b> B 97.70 C 167.00 D 100.90 E 5.00</p> 	

[11] Nitrided

[11] Nitridé

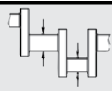
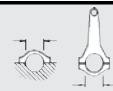
[11] Nitrurato

[11] Nitrurado

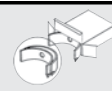
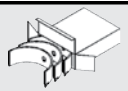
									
BE/PL	4	56.520/56.535	60.333/60.345	24.700	1.870	0.020/0.072	BS	1870CP	<b>71-4130/4</b> STD 0.25 0.50 0.75
<b>10/02 →</b>									
BE/PL	4	56.520/56.535	60.333/60.345	24.700	1.870	0.020/0.070	BS	66575CP	<b>71-4185/4</b> STD 0.25 0.50 0.75
<b>→09/82</b>									

1870CP

66575CP

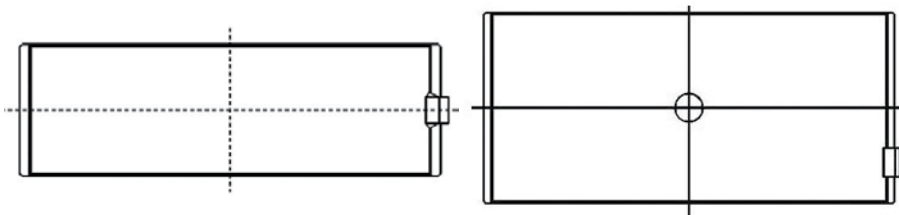









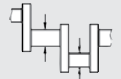

MB/HL 1-4	4	76.187/76.200	80.586/80.607	24.990	2.172	0.042/0.100	BS	66571CP	<b>H1049/5</b> STD 0.25 0.50 0.75
MB/HL 5	1	76.187/76.200	80.586/80.607	31.950	2.172	0.042/0.100	BS	66572CPH	

Mot. → 1846776

**1269**

 **93.00**

**Diesel**

									
MB/HL 1-4	4	76.187/76.200	80.586/80.607	24.990	2.172	0.038/0.097	BS	66573CP	<b>H1094/5</b> STD 0.25
MB/HL 5	1	76.187/76.200	80.586/80.607	31.950	2.172	0.038/0.097	BS	66574CPH	

Mot.1846777 →

**66571CP**

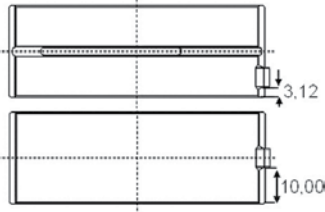

**66572CPH**

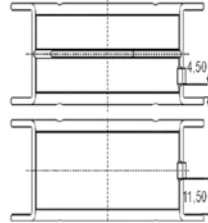

**66573CP**

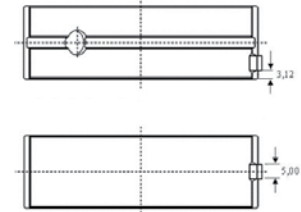

**66574CPH**

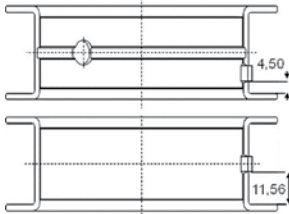

SE/PB	1	31.990/31.996	34.895/34.920	30.700			BS	66579YA	<b>55-4186</b> SEMI
-------	---	---------------	---------------	--------	--	--	----	---------	------------------------

09/82 →, Mot.344183 →









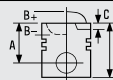

**1270**

 **93.00**

**Diesel**

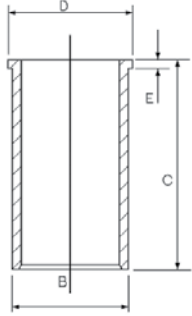

8144.61.500.81      4 Cyl.      22:1      2445cc      66kW (90)PS      Turbocharged      TD1054      **631**

			
<p><b>87-214500-00</b>      STD</p> <p><b>87-214508-00</b>      0.60mm</p> <p><b>A</b>    54.80</p> <p><b>B-</b>    2.20</p> <p><b>D</b>    89.80</p> <p> 32x75</p> <p><b>HA RT</b></p>	<p><b>08-214500-10</b>      STD</p> <p><b>08-214508-10</b>      0.60mm</p> <p>06/81 →</p> <p>3.00  CR P</p> <p>2.00  P</p> <p>4.00  CR P</p> <hr/> <p><b>08-214400-10</b>      STD</p> <p>01/78 →05/81</p> <p>2.00  CR P</p> <p>2.00  P</p> <p>4.00  CR P</p>	<p><b>14-021280-00 DH [11]</b></p> <p><b>B</b> 97.03    <b>C</b> 167.00    <b>D</b> 100.00    <b>E</b> 5.00</p> <p><b>14-022560-00 D</b></p> <p><b>B</b> 96.00    <b>C</b> 167.30    <b>D</b> 98.90    <b>E</b> 5.00</p> 	

[11] Nitrided









[11] Nitridé

[11] Niturato

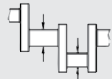
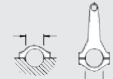
[11] Niturado

...Continued

**1270**  **93.00 Diesel**

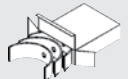
									
BE/PL	4	56.520/56.535	60.333/60.345	24.700	1.870	0.020/0.072	BS	1870CP	<b>71-4130/4</b> STD 0.25 0.50 0.75
BE/PL	4	56.520/56.535	60.333/60.345	24.700	1.870	0.020/0.070	BS	66575CP	<b>71-4185/4</b> STD 0.25 0.50 0.75

**1870CP**

**66575CP**

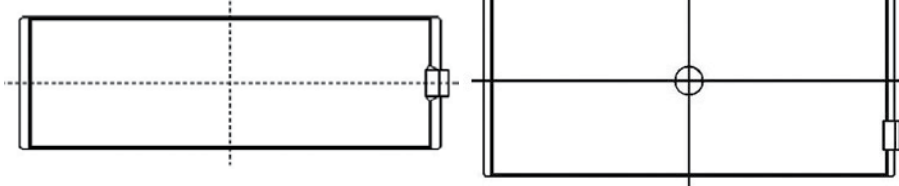

MB/HL 1-4	4	76.187/76.200	80.586/80.607	24.990	2.172	0.042/0.100	BS	66571CP	<b>H1049/5</b> STD 0.25 0.50 0.75
MB/HL 5	1	76.187/76.200	80.586/80.607	31.950	2.172	0.042/0.100	BS	66572CPH	
MB/HL 1-4	4	76.187/76.200	80.586/80.607	24.990	2.172	0.038/0.097	BS	66573CP	<b>H1094/5</b> STD 0.25
MB/HL 5	1	76.187/76.200	80.586/80.607	31.950	2.172	0.038/0.097	BS	66574CPH	

**66571CP**

**66572CPH**

**66573CP**

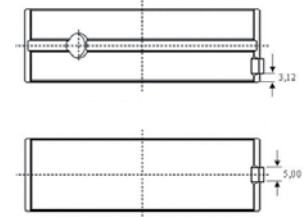
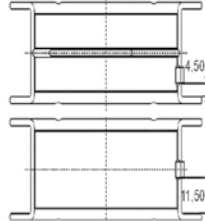
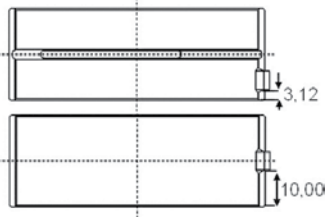

**66574CPH**

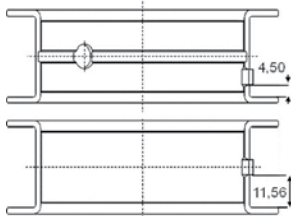

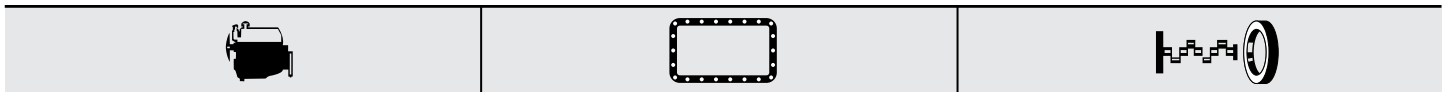

SE/PB	1	31.990/31.996	34.895/34.920	30.700			BS	66579YA	<b>55-4186</b> SEMI
-------	---	---------------	---------------	--------	--	--	----	---------	------------------------



**JJ100**  
(Cork)



**JJ100**

**NP067**  50.00x70.00x10.00mm, FPM  
**NF833**  90.00x115.00x13.00mm, FPM

## 1271

 93.00

**Diesel**



8144.91      4 Cyl.      22:1      2445cc      74kW (101)PS      Turbocharged      TD4600      633

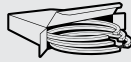
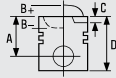







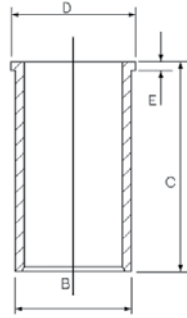

**08-245200-00** STD  
**08-245208-00** 0.60mm

3.00  CR P  
 2.00  P  
 3.00  CR P

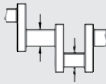
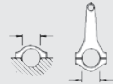
**14-021280-00 DH** [11]  
 B 97.03 C 167.00 D 100.00 E 5.00  
**14-028930-00 D**  
 B 97.50 C 167.00 D 100.90 E 5.00  
**14-028931-00 D**  
 B 97.58 C 167.00 D 100.90 E 5.00  
**14-028932-00 D**  
 B 97.70 C 167.00 D 100.90 E 5.00

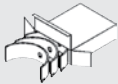

[11] Nitrided      [11] Nitridé      [11] Nitruato      [11] Nitruado

									
BE/PL	4	56.520/56.535	60.333/60.345	24.700	1.870	0.020/0.072	BS	1870CP	<b>71-4130/4</b> STD 0.25 0.50 0.75
BE/PL	4	56.520/56.535	60.333/60.345	24.700	1.870	0.020/0.070	BS	66575CP	<b>71-4185/4</b> STD 0.25 0.50 0.75





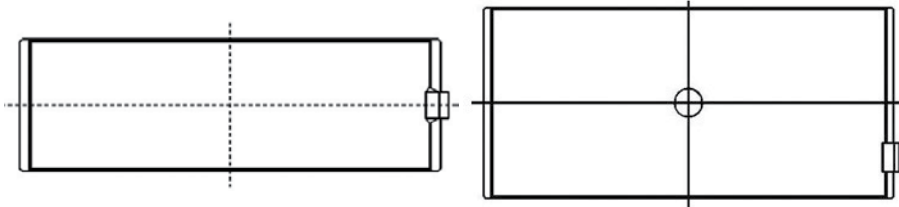



1870CP

66575CP

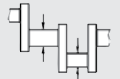
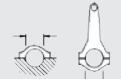

...Continued

**1271**  **93.00** Diesel

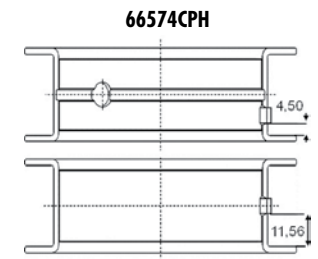
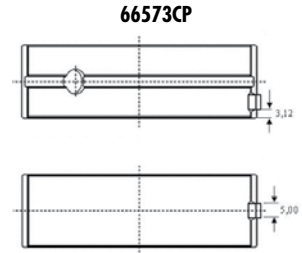
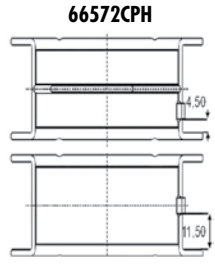
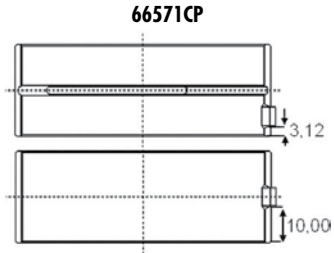

									
MB/HL 1-4	4	76.187/76.200	80.586/80.607	24.990	2.172	0.042/0.100	BS	66571CP	<b>H1049/5</b> STD 0.25 0.50 0.75
MB/HL 5	1	76.187/76.200	80.586/80.607	31.950	2.172	0.042/0.100	BS	66572CPH	
MB/HL 1-4	4	76.187/76.200	80.586/80.607	24.990	2.172	0.038/0.097	BS	66573CP	<b>H1094/5</b> STD 0.25
MB/HL 5	1	76.187/76.200	80.586/80.607	31.950	2.172	0.038/0.097	BS	66574CPH	

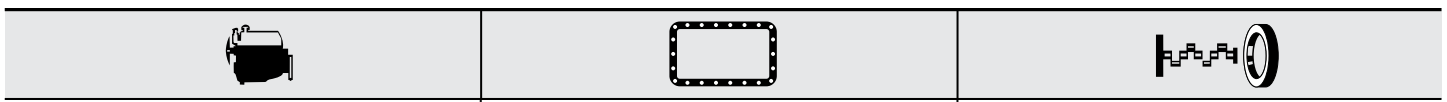

SE/PB	1	31.990/31.996	34.895/34.920	30.700			BS	66579YA	<b>55-4186</b> SEMI
-------	---	---------------	---------------	--------	--	--	----	---------	------------------------



JJ317

**NP068**  55.00x70.00x8.00mm, FPM  
**NF853**  100.00x118.00x10.00mm, FPM

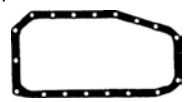

JJ317

## 1272

93.00

**Diesel**



8144.91.2000

4 Cyl.

22:1

2445cc

74kW (101)PS

Turbo Intercooled

TD1058

634

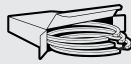
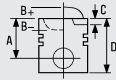

**08-245200-00** STD  
**08-245208-00** 0.60mm

3.00 CR P  
2.00 P  
3.00 CR P

**14-021280-00 DH [11]**  
B 97.03 C 167.00 D 100.00 E 5.00  
**14-022560-00 D**  
B 96.00 C 167.30 D 98.90 E 5.00

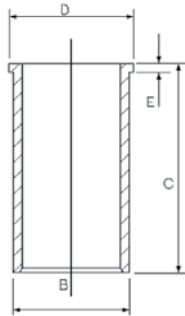

[11] Nitrided      [11] Nitridé      [11] Niturato      [11] Niturado

BE/PL	4	56.520/56.535	60.333/60.345	24.700	1.870	0.020/0.072	BS	1870CP	<b>71-4130/4</b> STD 0.25 0.50 0.75
BE/PL	4	56.520/56.535	60.333/60.345	24.700	1.870	0.020/0.070	BS	66575CP	<b>71-4185/4</b> STD 0.25 0.50 0.75

1870CP

66575CP

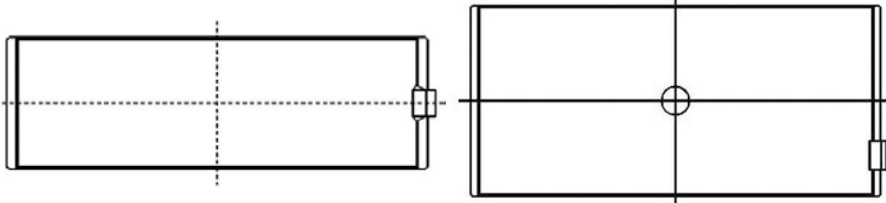

MB/HL 1-4	4	76.187/76.200	80.586/80.607	24.990	2.172	0.042/0.100	BS	66571CP	<b>H1049/5</b> STD 0.25 0.50 0.75
MB/HL 5	1	76.187/76.200	80.586/80.607	31.950	2.172	0.042/0.100	BS	66572CPH	
MB/HL 1-4	4	76.187/76.200	80.586/80.607	24.990	2.172	0.038/0.097	BS	66573CP	<b>H1094/5</b> STD 0.25
MB/HL 5	1	76.187/76.200	80.586/80.607	31.950	2.172	0.038/0.097	BS	66574CPH	

66571CP

66572CPH

66573CP

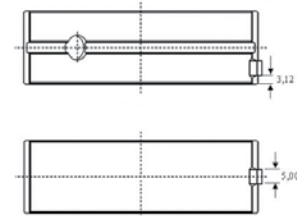
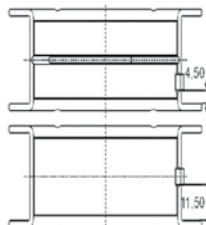
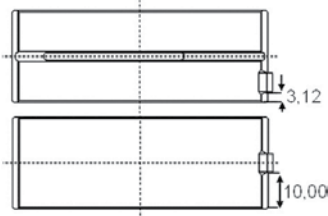



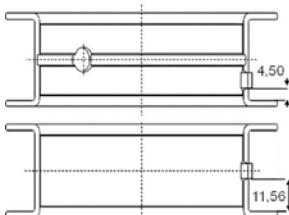





66574CPH











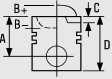





SE/PB	1	31.990/31.996	34.895/34.920	30.700			BS	66579YA	<b>55-4186</b> SEMI
-------	---	---------------	---------------	--------	--	--	----	---------	------------------------

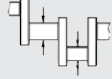
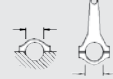

...Continued





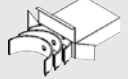

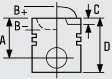

<b>1272</b>	 <b>93.00</b>	<b>Diesel</b>
		
		<b>NB946</b>  70.00x90.00x10.00mm, FPM <b>NF853</b>  100.00x118.00x10.00mm, FPM

<b>1273</b>	 <b>93.00</b>	<b>Diesel</b>			
<b>B 25.637</b>	4 Cyl.	22.25:1	2498cc	<b>51kW (69)PS</b>	<b>TD21463</b>

			
	<b>08-152700-00</b> STD <b>08-152707-00</b> 0.50mm  2.50  MOL P 2.00  P 4.00  CR P		

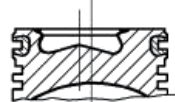
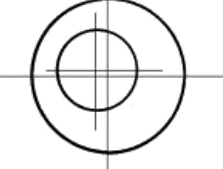
									
BE/PL	4	53.990/54.005	57.675/57.685	24.500	1.826	0.020/0.069	AL-LF	66440RAA	<b>01-4181/4</b> STD 0.25 0.50
MB/HL 1-5	5	67.035/67.050	71.695/71.705	28.700	2.317	0.020/0.061	AL-LF	66716RAA	<b>H1089/5</b> STD 0.25 0.50
TW/A	4	75.500/75.750	89.000/89.100		3.140		BS	66716BF	<b>A213/4</b> STD
SE/PB	1	30.008/30.014	33.000/33.033	31.900			BS	66444X	<b>55-4393</b> STD

<b>1274</b>	 <b>93.00</b>	<b>Diesel</b>			
<b>8140.07</b>	4 Cyl.	19:1	2499cc	<b>55kW (75)PS</b>	<b>FM19101</b>

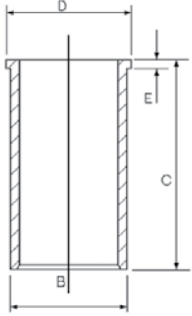
			
<b>87-425000-00</b> STD <b>87-425008-00</b> 0.60mm  A 58.75 B- 16.90 BØ 40.00 D 96.75     RT	<b>08-425000-00</b> STD <b>08-425008-00</b> 0.60mm  3.00  CR P 2.00  P 3.00  CR P	<b>14-021371-00 D</b> <b>B 96.01 C 171.00 D 98.92 E 5.00</b> <b>14-021372-00 D</b> <b>B 96.05 C 171.00 D 98.92 E 5.00</b> <b>14-021373-00 D</b> <b>B 96.17 C 171.00 D 98.92 E 5.00</b> <b>14-021480-00 DH [11]</b> <b>B 97.04 C 171.00 D 100.00 E 5.00</b>  	

[11] Nitrided

[11] Nitridé

[11] Niturato

[11] Niturado

## 1275

 93.00

**Diesel**



8140.07.2700

4 Cyl.

18:1

2499cc

55kW (75)PS

TD1700

635

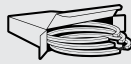
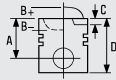

87-425000-00  
87-425008-00

STD  
0.60mm

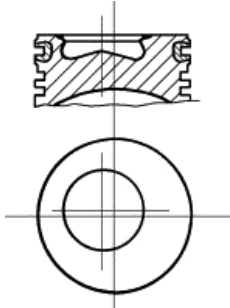

08-425000-00 STD  
08-425008-00 0.60mm









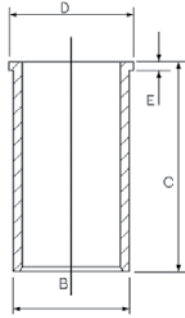



A 58.75  
B- 16.90  
BØ 40.00  
D 96.75  
32x75

RT

14-021371-00 D  
B 96.01 C 171.00 D 98.92 E 5.00  
14-021372-00 D  
B 96.05 C 171.00 D 98.92 E 5.00  
14-021373-00 D  
B 96.17 C 171.00 D 98.92 E 5.00  
14-021480-00 DH [11]  
B 97.04 C 171.00 D 100.00 E 5.00



[11] Nitrided [11] Nitridé [11] Nitruato [11] Nitruado

									
BE/PL	4	56.520/56.535	60.333/60.345	24.700	1.870	0.020/0.072	BS	1870CP	71-4130/4 STD 0.25 0.50 0.75
MB/HL 1-4	4	76.187/76.200	80.586/80.607	24.990	2.172	0.042/0.100	BS	66571CP	H1049/5 STD 0.25 0.50 0.75
MB/HL 5	1	76.187/76.200	80.586/80.607	31.950	2.172	0.042/0.100	BS	66572CPH	
→12/92, Mot.→1846776									
MB/HL 1-4	4	76.187/76.200	80.586/80.607	24.990	2.172	0.038/0.097	BS	66573CP	H1094/5 STD 0.25
MB/HL 5	1	76.187/76.200	80.586/80.607	31.950	2.172	0.038/0.097	BS	66574CPH	
Mot.1846777→									

66571CP

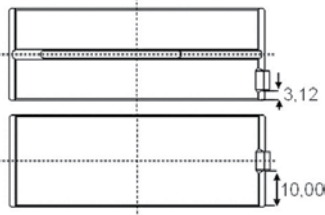

66572CPH

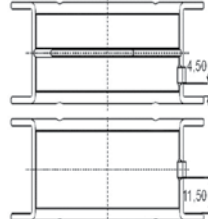

66573CP

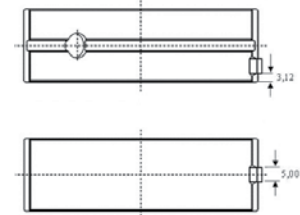



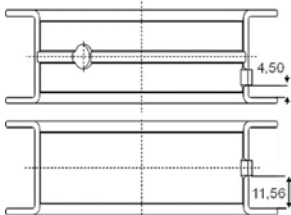







66574CPH













SE/PB	1	31.990/31.996	34.895/34.920	30.700			BS	66579YA	55-4186 SEMI
-------	---	---------------	---------------	--------	--	--	----	---------	-----------------

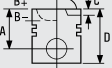
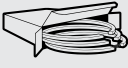

...Continued

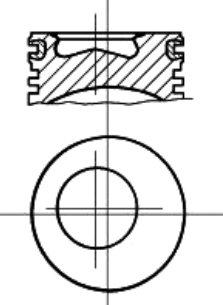
<b>1275</b>	 <b>93.00</b>	<b>Diesel</b>
		
	<p><b>JH5178</b> Soft Material Gasket <b>JJ519</b></p> <div style="display: flex; justify-content: space-around;">   </div> <p style="display: flex; justify-content: space-around;"><b>JH5178</b>      <b>JJ519</b></p>	<p><b>NP067</b>  50.00x70.00x10.00mm, FPM  <b>NF883</b>  114.00x177.00x13.00mm, FPM  <b>NF885</b>  70.00x179.00x16.00mm, FPM  <b>NF886</b>  100.00x179.00x15.80mm, FPM</p>

<b>1276</b>	 <b>93.00</b>	<b>Diesel</b>	
<b>8140.07.2701</b>	4 Cyl.	18:1	2499cc
		55kW (75)PS	<b>TD1701</b> <b>636</b>

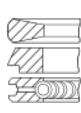
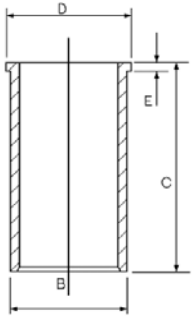
			
<p><b>87-425000-00</b>    STD  <b>87-425008-00</b>    0.60mm</p> <div style="display: flex; align-items: center;"> <div style="margin-right: 20px;"> <p><b>A</b>    58.75  <b>B-</b>    16.90  <b>BØ</b>    40.00  <b>D</b>    96.75   32x75</p> </div>  </div> <p><b>RT</b></p>	<p><b>08-425000-00</b>    STD  <b>08-425008-00</b>    0.60mm</p> <div style="display: flex; align-items: center;"> <div style="margin-right: 20px;"> <p>3.00  CR P  2.00  P  3.00  CR P</p> </div>  </div> <p>[11] Nitruato      [11] Nitruado</p>	<p><b>14-021371-00 D</b>  <b>B</b> 96.01    <b>C</b> 171.00    <b>D</b> 98.92    <b>E</b> 5.00  <b>14-021372-00 D</b>  <b>B</b> 96.05    <b>C</b> 171.00    <b>D</b> 98.92    <b>E</b> 5.00  <b>14-021373-00 D</b>  <b>B</b> 96.17    <b>C</b> 171.00    <b>D</b> 98.92    <b>E</b> 5.00  <b>14-021480-00 DH [11]</b>  <b>B</b> 97.04    <b>C</b> 171.00    <b>D</b> 100.00    <b>E</b> 5.00</p> <div style="text-align: center;">  </div>	

[11] Nitrided

[11] Nitridé









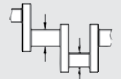

[11] Nitruato

[11] Nitruado

**1276**

 **93.00**

**Diesel**

									
BE/PL	4	56.520/56.535	60.333/60.345	24.700	1.870	0.020/0.072	BS	1870CP	<b>71-4130/4</b> STD 0.25 0.50 0.75
MB/HL 1-4	4	76.187/76.200	80.586/80.607	24.990	2.172	0.042/0.100	BS	66571CP	<b>H1049/5</b> STD 0.25 0.50 0.75
MB/HL 5	1	76.187/76.200	80.586/80.607	31.950	2.172	0.042/0.100	BS	66572CPH	
<b>Mot. → 1846776</b>									
MB/HL 1-4	4	76.187/76.200	80.586/80.607	24.990	2.172	0.038/0.097	BS	66573CP	<b>H1094/5</b> STD 0.25
MB/HL 5	1	76.187/76.200	80.586/80.607	31.950	2.172	0.038/0.097	BS	66574CPH	

**Mot. 1846777 →**

**66571CP**

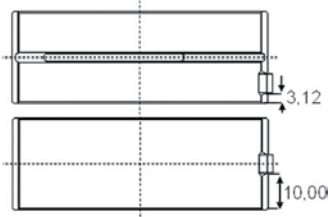

**66572CPH**

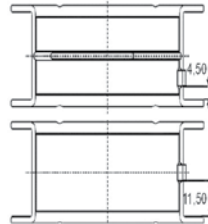

**66573CP**

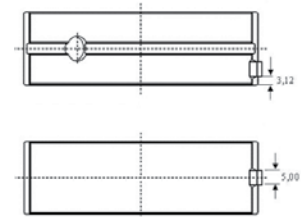

**66574CPH**

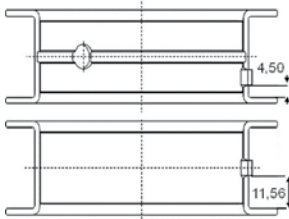





SE/PB	1	31.990/31.996	34.895/34.920	30.700			BS	66579YA	<b>55-4186</b> SEMI
-------	---	---------------	---------------	--------	--	--	----	---------	------------------------













**JJ100**  
(Cork)

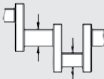
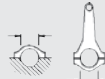

**JJ100**

- NP067**  50.00x70.00x10.00mm, FPM
- NF883**  114.00x177.00x13.00mm, FPM
- NF885**  70.00x179.00x16.00mm, FPM
- NF886**  100.00x179.00x15.80mm, FPM

<b>1277</b>	 <b>93.00</b>	<b>Diesel</b>				
8140.07.2710	4 Cyl.	18:1	2499cc	55kW (75)PS		<b>TD27358</b> <b>613</b>
8140.07.2711	4 Cyl.	18:1	2499cc	55kW (75)PS		<b>TD27359</b> <b>613</b>
8140.07.2713	4 Cyl.	18:1	2499cc	55kW (75)PS		<b>TD27360</b>
8140.07.3711 Euro 1	4 Cyl.	19:1	2499cc	53kW (72)PS		<b>TD27365</b> <b>613</b>
8140.07.3712 Euro 1	4 Cyl.	19:1	2499cc	53kW (72)PS		<b>TD27366</b> <b>613</b>
8140.07.3713 Euro 1	4 Cyl.	19:1	2499cc	53kW (72)PS		<b>TD27367</b> <b>613</b>
8140.27.215	4 Cyl.	18.5:1	2499cc	76kW (103)PS	<b>Turbocharged</b>	<b>TD27387</b> <b>639</b>
8140.27R.2780	4 Cyl.	18:1	2499cc	67-70kW (91-95)PS	<b>Turbocharged</b>	<b>TD27393</b>
8140.27R.2786	4 Cyl.	18:1	2499cc	67-70kW (91-95)PS	<b>Turbocharged</b>	<b>TD27394</b> <b>646</b>
8140.27R.2787	4 Cyl.	18:1	2499cc	67-70kW (91-95)PS	<b>Turbocharged</b>	<b>TD27395</b>
8140.27S.2701	4 Cyl.	18:1	2499cc	76kW (103)PS	<b>Turbocharged</b>	<b>TD27396</b> <b>639</b>
8140.27S.2710	4 Cyl.	18:1	2499cc	76kW (103)PS	<b>Turbocharged</b>	<b>TD27397</b> <b>639</b>
8140.27S.2711	4 Cyl.	18:1	2499cc	76kW (103)PS	<b>Turbocharged</b>	<b>TD27398</b> <b>639</b>
8140.27S.2720	4 Cyl.	18:1	2499cc	76kW (103)PS	<b>Turbocharged</b>	<b>TD27399</b> <b>639</b>
8140.27S.2721	4 Cyl.	18:1	2499cc	76kW (103)PS	<b>Turbocharged</b>	<b>TD27400</b> <b>639</b>
8140.27S.2730	4 Cyl.	18:1	2499cc	76kW (103)PS	<b>Turbocharged</b>	<b>TD27401</b> <b>639</b>
8140.27S.2731	4 Cyl.	18:1	2499cc	76kW (103)PS	<b>Turbocharged</b>	<b>TD27402</b> <b>639</b>
8140.27S.2750	4 Cyl.	18:1	2499cc	76kW (103)PS	<b>Turbocharged</b>	<b>TD27403</b> <b>639</b>
8140.27S.2751	4 Cyl.	18:1	2499cc	76kW (103)PS	<b>Turbocharged</b>	<b>TD27404</b>
8140.27S.2760	4 Cyl.	18:1	2499cc	76kW (103)PS	<b>Turbocharged</b>	<b>TD27405</b> <b>648</b>
8140.27S.2761	4 Cyl.	18:1	2499cc	76kW (103)PS	<b>Turbocharged</b>	<b>TD27406</b> <b>649</b>
8140.27S.2770	4 Cyl.	18:1	2499cc	76kW (103)PS	<b>Turbocharged</b>	<b>TD27407</b> <b>639</b>
8140.27S.2771	4 Cyl.	18:1	2499cc	76kW (103)PS	<b>Turbocharged</b>	<b>TD27408</b> <b>639</b>
8140.27S.2811	4 Cyl.	18:1	2499cc	76kW (103)PS	<b>Turbocharged</b>	<b>TD27409</b> <b>639</b>
8140.27S.3700	4 Cyl.	18.5:1	2499cc	77kW (104)PS	<b>Turbocharged</b>	<b>TD27410</b>
8140.27S.3701	4 Cyl.	18.5:1	2499cc	77kW (104)PS	<b>Turbocharged</b>	<b>TD27411</b> <b>639</b>
8140.27S.3711	4 Cyl.	18.5:1	2499cc	77kW (104)PS	<b>Turbocharged</b>	<b>TD27412</b> <b>639</b>
8140.27S.3720	4 Cyl.	18.5:1	2499cc	77kW (104)PS	<b>Turbocharged</b>	<b>TD27413</b> <b>639</b>
8140.27S.3721	4 Cyl.	18.5:1	2499cc	77kW (104)PS	<b>Turbocharged</b>	<b>TD27414</b> <b>639</b>
8140.27S.3750	4 Cyl.	18.5:1	2499cc	77kW (104)PS	<b>Turbocharged</b>	<b>TD27415</b> <b>639</b>
8140.27S.3751	4 Cyl.	18.5:1	2499cc	77kW (104)PS	<b>Turbocharged</b>	<b>TD27416</b> <b>639</b>
8140.27S.3760	4 Cyl.	18.5:1	2499cc	77kW (104)PS	<b>Turbocharged</b>	<b>TD27419</b> <b>639</b>
8140.27S.3761	4 Cyl.	18.5:1	2499cc	77kW (104)PS	<b>Turbocharged</b>	<b>TD27420</b> <b>639</b>
8140.27S.3770	4 Cyl.	18.5:1	2499cc	77kW (104)PS	<b>Turbocharged</b>	<b>TD27422</b> <b>648</b>
8140.27S.3771	4 Cyl.	18.5:1	2499cc	77kW (104)PS	<b>Turbocharged</b>	<b>TD27423</b> <b>639</b>
8140.27S.3780	4 Cyl.	18.5:1	2499cc	77kW (104)PS	<b>Turbocharged</b>	<b>TD27424</b> <b>639</b>
8140.27S.3781	4 Cyl.	18.5:1	2499cc	77kW (104)PS	<b>Turbocharged</b>	<b>TD27425</b>
8140.27S.3811	4 Cyl.	18.5:1	2499cc	77kW (104)PS	<b>Turbocharged</b>	<b>TD27426</b> <b>649</b>

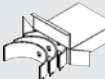







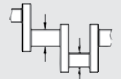

									
BE/PL	4	56.520/56.535	60.333/60.345	24.700	1.870	0.020/0.072	BS	1870CP	<b>71-4130/4</b> STD 0.25 0.50 0.75
MB/HL 1-4	4	76.187/76.200	80.586/80.607	24.990	2.172	0.042/0.100	BS	66571CP	<b>H1049/5</b> STD 0.25 0.50 0.75
MB/HL 5	1	76.187/76.200	80.586/80.607	31.950	2.172	0.042/0.100	BS	66572CPH	

Mot. → 1846776

# FIAT GROUP

...Continued

## 1277 93.00 Diesel

									
MB/HL 1-4	4	76.187/76.200	80.586/80.607	24.990	2.172	0.038/0.097	BS	66573CP	<b>H1094/5</b> STD 0.25
MB/HL 5	1	76.187/76.200	80.586/80.607	31.950	2.172	0.038/0.097	BS	66574CPH	



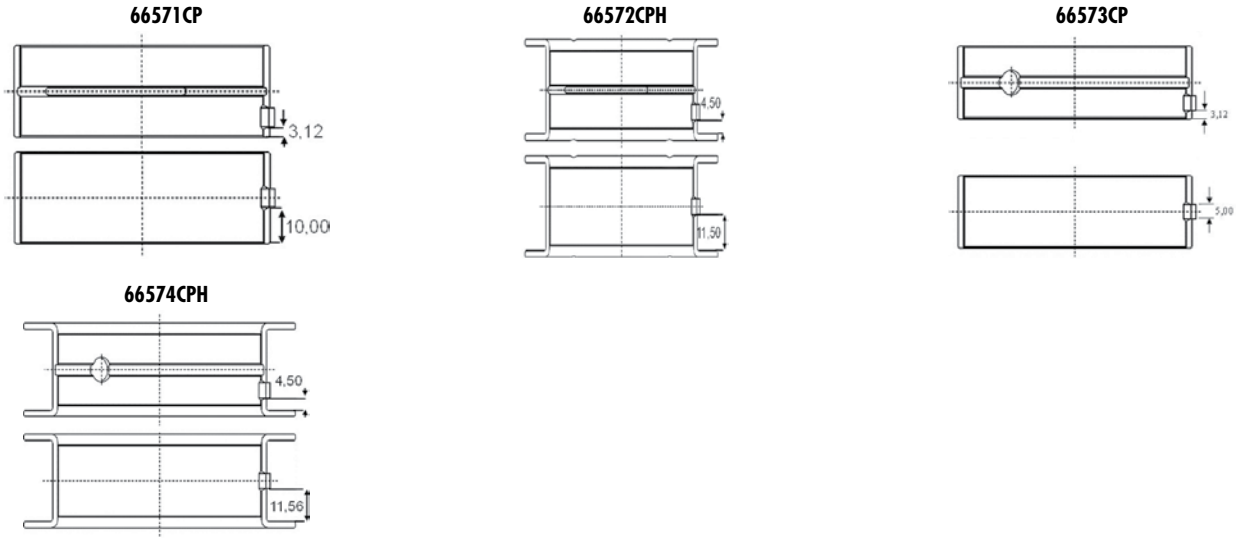







Mot.1846777 →

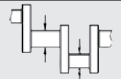

SE/PB	1	31.990/31.996	34.895/34.920	30.700			BS	66579YA	<b>55-4186</b> SEMI
-------	---	---------------	---------------	--------	--	--	----	---------	------------------------

## 1278 93.00 Diesel









8140.07.2712 4 Cyl. 18:1 2499cc 55kW (75)PS TD1702 637

									
BE/PL	4	56.520/56.535	60.333/60.345	24.700	1.870	0.020/0.072	BS	1870CP	<b>71-4130/4</b> STD 0.25 0.50 0.75
MB/HL 1-4	4	76.187/76.200	80.586/80.607	24.990	2.172	0.042/0.100	BS	66571CP	<b>H1049/5</b> STD 0.25 0.50 0.75
MB/HL 5	1	76.187/76.200	80.586/80.607	31.950	2.172	0.042/0.100	BS	66572CPH	

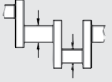
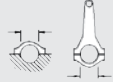
01/93 → 12/94

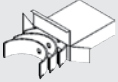

...Continued

**1278**  **93.00 Diesel**

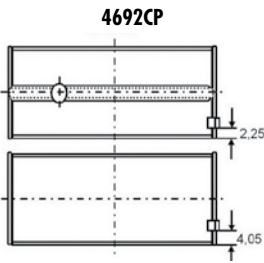
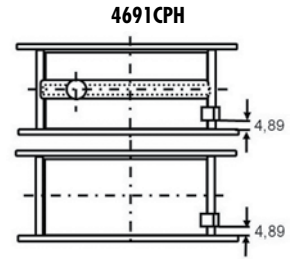
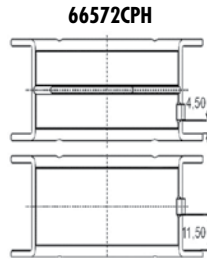
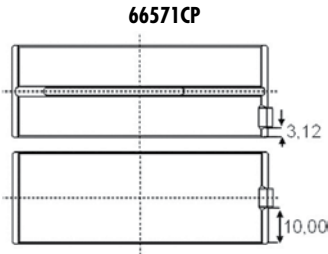

									
MB/HL 5	1	86.182/86.208	90.588/90.614	30.950	2.164	0.052/0.129	BS	4691CPH	<b>H1104/5</b> STD 0.25 0.50
MB/HL 1-4	4	80.182/80.208	84.588/84.614	23.800	2.164	0.052/0.129	BS	4692CP	

01/95 →

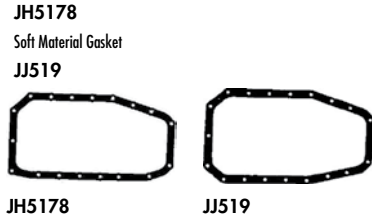

		
---	---	---



**NP067**  50.00x70.00x10.00mm, FPM  
**NA5305**  [18]  
01/01 →

[18] Outer Diameter 1 [mm]: 105.00

[18] Diamètre extérieur 1 [mm]: 105.00

[18] Diametro esterno 1 [mm]: 105.00

[18] Diámetro exterior 1[mm]: 105.00

## 1279

 93.00

**Diesel**



8140.07.3700 Euro 1

4 Cyl.

19:1

2499cc

53kW (72)PS

TD27364

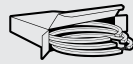
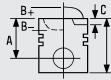







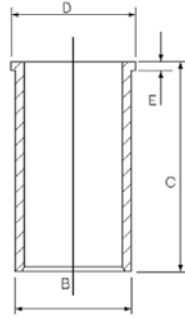

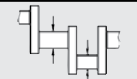

**08-425000-00** STD  
**08-425008-00** 0.60mm

3.00  CR P  
2.00  P  
3.00  CR P

**14-021371-00 D**  
B 96.01 C 171.00 D 98.92 E 5.00  
**14-021372-00 D**  
B 96.05 C 171.00 D 98.92 E 5.00  
**14-021373-00 D**  
B 96.17 C 171.00 D 98.92 E 5.00  
**14-021480-00 DH [11]**  
B 97.04 C 171.00 D 100.00 E 5.00



[11] Nitrided [11] Nitridé [11] Nitrurato [11] Nitrado

									
BE/PL	4	56.520/56.535	60.333/60.345	24.700	1.870	0.020/0.072	BS	1870CP	<b>71-4130/4</b> STD 0.25 0.50 0.75
MB/HL 1-4	4	76.187/76.200	80.586/80.607	24.990	2.172	0.042/0.100	BS	66571CP	<b>H1049/5</b> STD 0.25 0.50 0.75
MB/HL 5	1	76.187/76.200	80.586/80.607	31.950	2.172	0.042/0.100	BS	66572CPH	
<b>Mot. → 1846776</b>									
MB/HL 1-4	4	76.187/76.200	80.586/80.607	24.990	2.172	0.038/0.097	BS	66573CP	<b>H1094/5</b> STD 0.25
MB/HL 5	1	76.187/76.200	80.586/80.607	31.950	2.172	0.038/0.097	BS	66574CPH	

**Mot. 1846777 →**

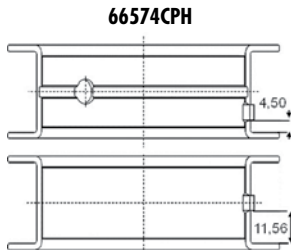
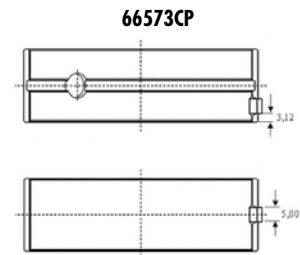
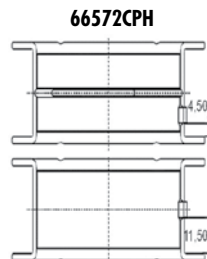
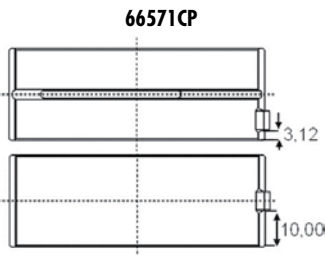

SE/PB	1	31.990/31.996	34.895/34.920	30.700			BS	66579YA	<b>55-4186</b> SEMI
-------	---	---------------	---------------	--------	--	--	----	---------	------------------------

## 1280

## 93.00

## Diesel



8140.07.3710 Euro 1

4 Cyl.

19:1

2499cc

53kW (72)PS

TD20418

638

<p><b>87-425000-00</b> STD <b>87-425008-00</b> 0.60mm</p> <p>A 58.75 B- 16.90 BØ 40.00 D 96.75 32x75</p> <p>RT</p>		<p><b>08-425000-00</b> STD <b>08-425008-00</b> 0.60mm</p> <p>3.00 CR P 2.00 P 3.00 CR P</p>	<p><b>14-021371-00 D</b> B 96.01 C 171.00 D 98.92 E 5.00 <b>14-021372-00 D</b> B 96.05 C 171.00 D 98.92 E 5.00 <b>14-021373-00 D</b> B 96.17 C 171.00 D 98.92 E 5.00 <b>14-021480-00 DH [11]</b> B 97.04 C 171.00 D 100.00 E 5.00</p>

[11] Nitrided

[11] Nitridé

[11] Niturato

[11] Niturado

BE/PL	4	56.520/56.535	60.333/60.345	24.700	1.870	0.020/0.072	BS	1870CP	<b>71-4130/4</b> STD 0.25 0.50 0.75
MB/HL 1-4	4	76.187/76.200	80.586/80.607	24.990	2.172	0.042/0.100	BS	66571CP	<b>H1049/5</b> STD 0.25 0.50 0.75
MB/HL 5	1	76.187/76.200	80.586/80.607	31.950	2.172	0.042/0.100	BS	66572CPH	
<b>Mot. → 1846776</b>									
MB/HL 1-4	4	76.187/76.200	80.586/80.607	24.990	2.172	0.038/0.097	BS	66573CP	<b>H1094/5</b> STD 0.25
MB/HL 5	1	76.187/76.200	80.586/80.607	31.950	2.172	0.038/0.097	BS	66574CPH	

**Mot. 1846777 →**

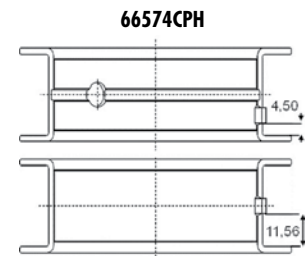
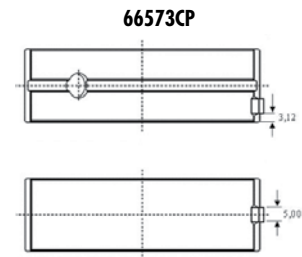
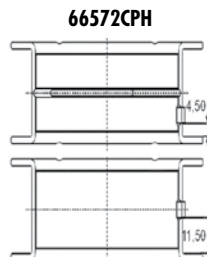
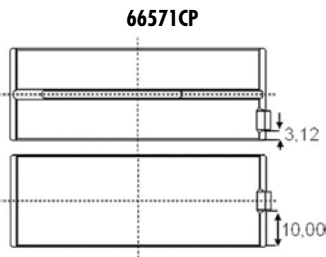

SE/PB	1	31.990/31.996	34.895/34.920	30.700			BS	66579YA	<b>55-4186</b> SEMI
-------	---	---------------	---------------	--------	--	--	----	---------	------------------------

# FIAT GROUP

...Continued

<b>1280</b>	<b>93.00</b>	<b>Diesel</b>
	<b>JJ519</b> 	<b>NP067</b> 50.00x70.00x10.00mm, FPM
	<b>JJ519</b> 	

<b>1281</b>	<b>93.00</b>	<b>Diesel</b>
<b>8140.27.218</b>	4 Cyl.	18.5:1
2499cc	76kW (103)PS	Turbocharged
	<b>08-245200-00</b> STD <b>08-245208-00</b> 0.60mm  3.00  CR P 2.00  P 3.00  CR P	<b>14-021371-00 D</b> <b>B</b> 96.01 <b>C</b> 171.00 <b>D</b> 98.92 <b>E</b> 5.00 <b>14-021372-00 D</b> <b>B</b> 96.05 <b>C</b> 171.00 <b>D</b> 98.92 <b>E</b> 5.00 <b>14-021373-00 D</b> <b>B</b> 96.17 <b>C</b> 171.00 <b>D</b> 98.92 <b>E</b> 5.00 <b>14-021480-00 DH</b> [11] <b>B</b> 97.04 <b>C</b> 171.00 <b>D</b> 100.00 <b>E</b> 5.00  
[11] Nitrided	[11] Nitridé	[11] Niturato
	[11] Niturado	

BE/PL	4	56.520/56.535	60.333/60.345	24.700	1.870	0.020/0.072	BS	1870CP	<b>71-4130/4</b> STD 0.25 0.50 0.75
BE/PL	4	56.520/56.535	60.333/60.345	24.700	1.870	0.020/0.070	BS	66575CP	<b>71-4185/4</b> STD 0.25 0.50 0.75

1870CP



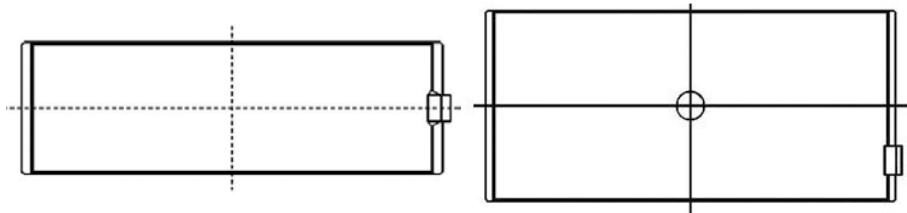





66575CP



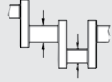
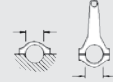

...Continued

**1281**  **93.00 Diesel**

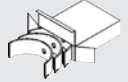
									
MB/HL 1-4	4	76.187/76.200	80.586/80.607	24.990	2.172	0.042/0.100	BS	66571CP	H1049/5 STD 0.25 0.50 0.75
MB/HL 5	1	76.187/76.200	80.586/80.607	31.950	2.172	0.042/0.100	BS	66572CPH	
<b>Mot. → 1846776</b>									
MB/HL 1-4	4	76.187/76.200	80.586/80.607	24.990	2.172	0.038/0.097	BS	66573CP	H1094/5 STD 0.25
MB/HL 5	1	76.187/76.200	80.586/80.607	31.950	2.172	0.038/0.097	BS	66574CPH	
<b>Mot. 1846777 →</b>									

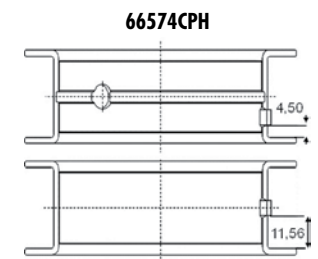
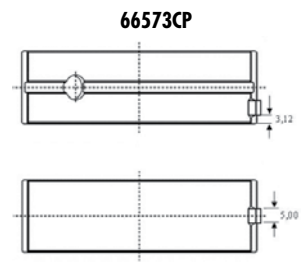
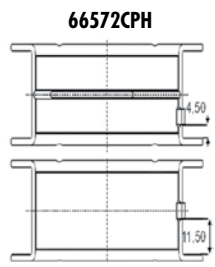
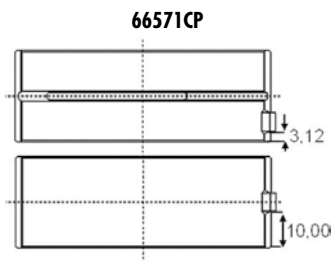

SE/PB	1	31.990/31.996	34.895/34.920	30.700			BS	66579YA	55-4186 SEMI
-------	---	---------------	---------------	--------	--	--	----	---------	-----------------

## 1282

 93.00

**Diesel**



8140.27.2582

4 Cyl.

18.5:1

2499cc

74-79kW (101-107)PS

Turbocharged

TD7260

640

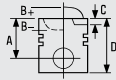

**87-245200-40**  
**87-245208-40**

STD  
0.60mm

A 58.75  
B- 17.90  
BØ 38.00  
D 96.75  
 32x75

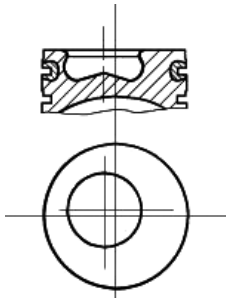

**08-245200-00** STD  
**08-245208-00** 0.60mm

3.00  CR P  
2.00  P  
3.00  CR P

**14-021371-00 D**  
B 96.01 C 171.00 D 98.92 E 5.00  
**14-021372-00 D**  
B 96.05 C 171.00 D 98.92 E 5.00  
**14-021373-00 D**  
B 96.17 C 171.00 D 98.92 E 5.00  
**14-021480-00 DH [11]**  
B 97.04 C 171.00 D 100.00 E 5.00

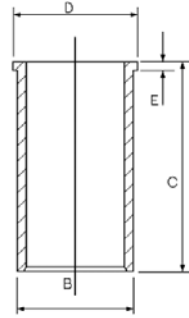

RT

**87-245200-50**  
**87-245208-50**

STD  
0.60mm

A 58.75  
B- 17.90  
BØ 38.00  
D 96.75  
 32x78

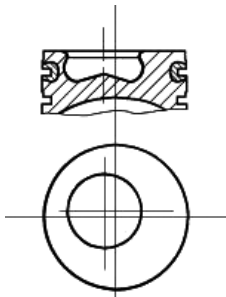

**08-245200-00** STD  
**08-245208-00** 0.60mm

3.00  CR P  
2.00  P  
3.00  CR P

AK NB RT

[11] Nitrided









[11] Nitridé

[11] Nitruato

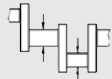
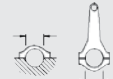
[11] Nitruado

...Continued

**1282**  **93.00** Diesel

									
BE/PL	4	56.520/56.535	60.333/60.345	24.700	1.870	0.020/0.072	BS	1870CP	71-4130/4 STD 0.25 0.50 0.75
MB/HL 1-4	4	76.187/76.200	80.586/80.607	24.990	2.172	0.042/0.100	BS	66571CP	H1049/5 STD 0.25 0.50 0.75
MB/HL 5	1	76.187/76.200	80.586/80.607	31.950	2.172	0.042/0.100	BS	66572CPH	
→12/92									
MB/HL 5	1	86.182/86.208	90.588/90.614	30.950	2.164	0.052/0.129	BS	4691CPH	H1104/5 STD 0.25 0.50
MB/HL 1-4	4	80.182/80.208	84.588/84.614	23.800	2.164	0.052/0.129	BS	4692CP	

09/85 →

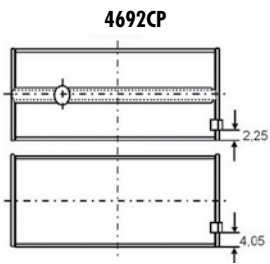
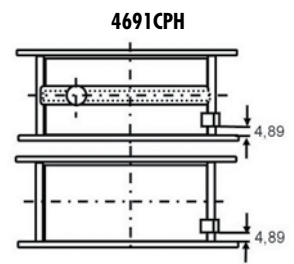
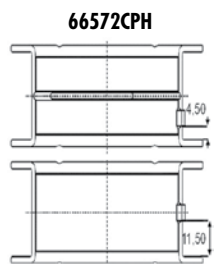
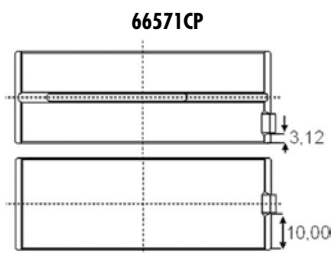

SE/PB	1	31.990/31.996	34.895/34.920	30.700			BS	66579YA	55-4186 SEMI
-------	---	---------------	---------------	--------	--	--	----	---------	-----------------

Mot.344183 →

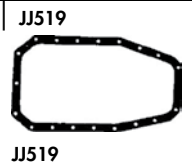
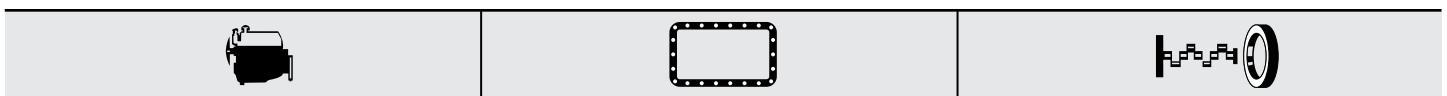



8140.27.2700

4 Cyl.

18:1

2499cc

76kW (103)PS

Turbocharged

TD1706

641

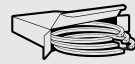
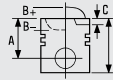

87-245200-40  
87-245208-40

STD  
0.60mm

A 58.75  
B- 17.90  
BØ 38.00  
D 96.75  
32x75

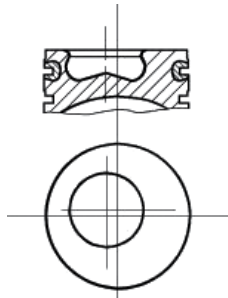

08-245200-00 STD  
08-245208-00 0.60mm

3.00 CR P  
2.00 P  
3.00 CR P



14-021371-00 D  
B 96.01 C 171.00 D 98.92 E 5.00  
14-021372-00 D  
B 96.05 C 171.00 D 98.92 E 5.00  
14-021373-00 D  
B 96.17 C 171.00 D 98.92 E 5.00  
14-021480-00 DH [11]  
B 97.04 C 171.00 D 100.00 E 5.00

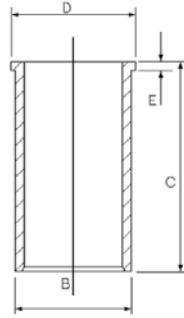

RT

87-245200-50  
87-245208-50

STD  
0.60mm

A 58.75  
B- 17.90  
BØ 38.00  
D 96.75  
32x78

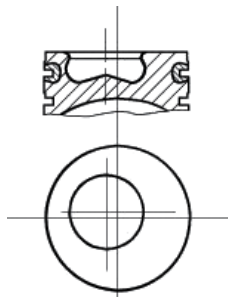

08-245200-00 STD  
08-245208-00 0.60mm

3.00 CR P  
2.00 P  
3.00 CR P



AK NB RT

[11] Nitrided

[11] Nitridé

[11] Niturato

[11] Niturado

Part	QTY	Part	QTY	Part	QTY	Part	QTY	Part	QTY	Part	QTY
BE/PL	4	56.520/56.535	60.333/60.345	24.700	1.870	0.020/0.072	BS	1870CP	71-4130/4	STD 0.25 0.50 0.75	
MB/HL 1-4	4	76.187/76.200	80.586/80.607	24.990	2.172	0.042/0.100	BS	66571CP	H1049/5	STD 0.25 0.50 0.75	
MB/HL 5	1	76.187/76.200	80.586/80.607	31.950	2.172	0.042/0.100	BS	66572CPH			
→12/92											
MB/HL 1-4	4	76.187/76.200	80.586/80.607	24.990	2.172	0.038/0.097	BS	66573CP	H1094/5	STD 0.25	
MB/HL 5	1	76.187/76.200	80.586/80.607	31.950	2.172	0.038/0.097	BS	66574CPH			
01/93→08/95											
MB/HL 5	1	86.182/86.208	90.588/90.614	30.950	2.164	0.052/0.129	BS	4691CPH	H1104/5	STD 0.25 0.50	
MB/HL 1-4	4	80.182/80.208	84.588/84.614	23.800	2.164	0.052/0.129	BS	4692CP			
09/95→											

66571CP

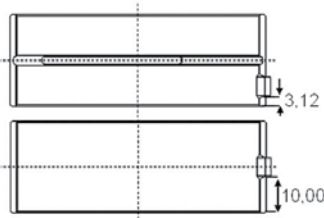

66572CPH

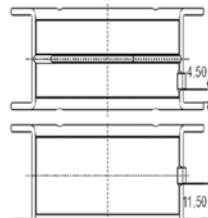

66573CP

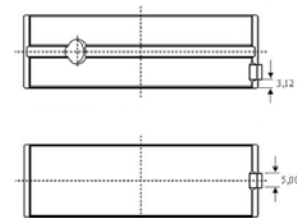

...Continued

**1283**  **93.00 Diesel**

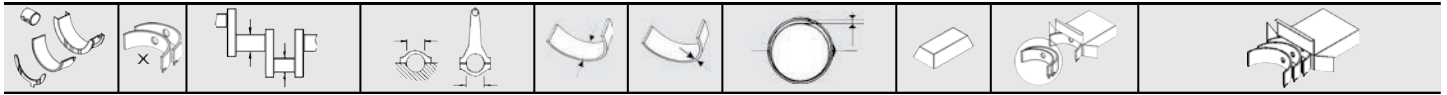

**66574CPH**

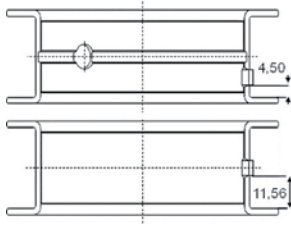

**4691CPH**

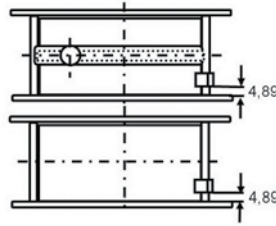

**4692CP**

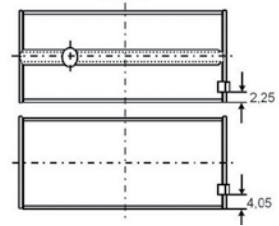

SE/PB	1	31.990/31.996	34.895/34.920	30.700		BS	66579YA	<b>55-4186</b> SEMI
-------	---	---------------	---------------	--------	--	----	---------	------------------------

Mot.344183 →

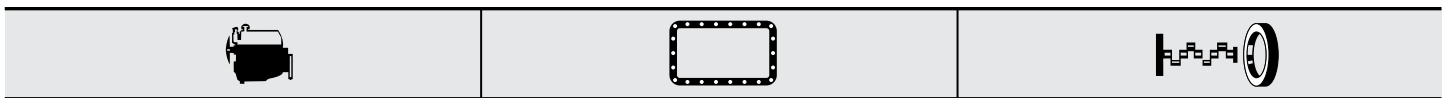

**JH5178**  
Soft Material Gasket  
**JJ519**











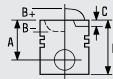

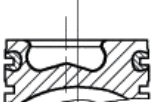
**NF833**  90.00x115.00x13.00mm, FPM

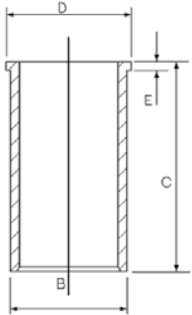

**JH5178**      **JJ519**

**1284**  **93.00 Diesel** 

**8140.27.2720**      4 Cyl.      18:1      2499cc      **76kW (103)PS**      **TD1707**      **641**

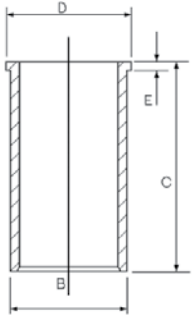
 <p><b>87-245200-40</b>      STD <b>87-245208-40</b>      0.60mm</p> <p><b>A</b> 58.75 <b>B-</b> 17.90 <b>BØ</b> 38.00 <b>D</b> 96.75  32x75</p> <p><b>RT</b></p>	 <p><b>08-245200-00</b>      STD <b>08-245208-00</b>      0.60mm</p> <p>3.00  CR P 2.00  P 3.00  CR P</p>	 <p><b>14-021371-00 D</b> <b>B</b> 96.01    <b>C</b> 171.00    <b>D</b> 98.92    <b>E</b> 5.00 <b>14-021372-00 D</b> <b>B</b> 96.05    <b>C</b> 171.00    <b>D</b> 98.92    <b>E</b> 5.00 <b>14-021373-00 D</b> <b>B</b> 96.17    <b>C</b> 171.00    <b>D</b> 98.92    <b>E</b> 5.00 <b>14-021480-00 DH [11]</b> <b>B</b> 97.04    <b>C</b> 171.00    <b>D</b> 100.00    <b>E</b> 5.00</p> 	
<p><b>87-245200-50</b>      STD <b>87-245208-50</b>      0.60mm</p> <p><b>A</b> 58.75 <b>B-</b> 17.90 <b>BØ</b> 38.00 <b>D</b> 96.75  32x78</p> <p><b>AK NB RT</b></p>	<p><b>08-245200-00</b>      STD <b>08-245208-00</b>      0.60mm</p> <p>3.00  CR P 2.00  P 3.00  CR P</p>		

[11] Nitrided      [11] Nitridé      [11] Nitrurato      [11] Nitrurado





**1284**

 **93.00**

**Diesel**



**JH5178**  
Soft Material Gasket  
**JJ519**

**NP067**  50.00x70.00x10.00mm, FPM  
**NF885**  70.00x179.00x16.00mm, FPM  
**NF833**  90.00x115.00x13.00mm, FPM  
**NF886**  100.00x179.00x15.80mm, FPM



JH5178

JJ519

**1285**

 **93.00**

**Diesel**



8140.27.2811

4 Cyl.

18:1

2499cc

76kW (103)PS

TD1708

642

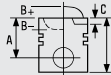

**87-245200-40**  
**87-245208-40**

STD  
0.60mm

**A** 58.75  
**B-** 17.90  
**BØ** 38.00  
**D** 96.75  
 32x75

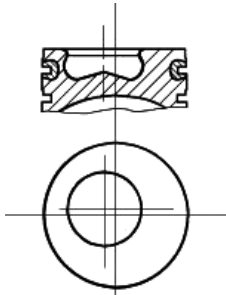

RT

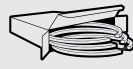

**08-245200-00** STD  
**08-245208-00** 0.60mm

3.00  CR P  
2.00  P  
3.00  CR P



**14-021371-00 D**  
**B** 96.01 **C** 171.00 **D** 98.92 **E** 5.00  
**14-021372-00 D**  
**B** 96.05 **C** 171.00 **D** 98.92 **E** 5.00  
**14-021373-00 D**  
**B** 96.17 **C** 171.00 **D** 98.92 **E** 5.00  
**14-021480-00 DH [11]**  
**B** 97.04 **C** 171.00 **D** 100.00 **E** 5.00

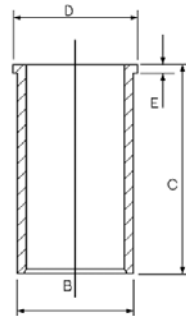

**87-245200-50**  
**87-245208-50**

STD  
0.60mm

**A** 58.75  
**B-** 17.90  
**BØ** 38.00  
**D** 96.75  
 32x78

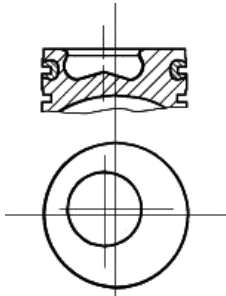

AK NB RT

**08-245200-00** STD  
**08-245208-00** 0.60mm

3.00  CR P  
2.00  P  
3.00  CR P

[11] Nitrided

[11] Nitridé

[11] Niturato

[11] Niturado



**JJ519**

**NP067**  50.00x70.00x10.00mm, FPM



JJ519











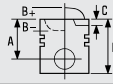
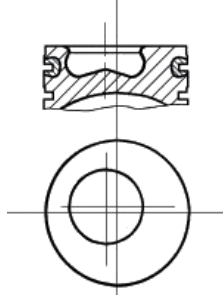

## 1286

 93.00

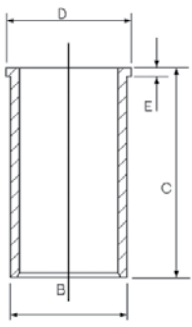
**Diesel**

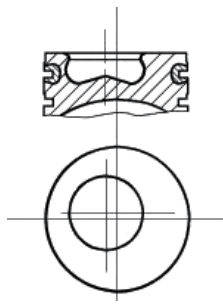

<b>8140.27R.2700</b>	4 Cyl.	18:1	2499cc	<b>67-70kW (92-95)PS</b>	<b>Turbocharged</b>	<b>TD20420</b>	<b>643</b>
<b>8140.27S.2885</b>	4 Cyl.	18:1	2499cc	<b>76kW (103)PS</b>	<b>Turbocharged</b>	<b>TD20422</b>	<b>651</b>

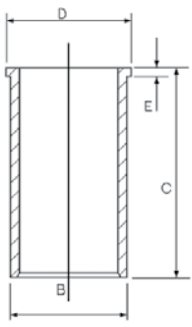







 <p><b>87-245200-40</b> <b>87-245208-40</b></p> <p>STD 0.60mm</p>  <p>A 58.75 B- 17.90 BØ 38.00 D 96.75  32x75</p> <p>RT</p>	 <p><b>08-245200-00</b> STD <b>08-245208-00</b> 0.60mm</p> <p>3.00  CR P 2.00  P 3.00  CR P</p>	 <p><b>14-021371-00 D</b> B 96.01 C 171.00 D 98.92 E 5.00 <b>14-021372-00 D</b> B 96.05 C 171.00 D 98.92 E 5.00 <b>14-021373-00 D</b> B 96.17 C 171.00 D 98.92 E 5.00 <b>14-021480-00 DH [11]</b> B 97.04 C 171.00 D 100.00 E 5.00</p> 	
<p><b>87-245200-50</b> <b>87-245208-50</b></p> <p>STD 0.60mm</p>  <p>A 58.75 B- 17.90 BØ 38.00 D 96.75  32x78</p> <p>AK NB RT</p>	<p><b>08-245200-00</b> STD <b>08-245208-00</b> 0.60mm</p> <p>3.00  CR P 2.00  P 3.00  CR P</p>		

[11] Nitrided

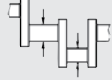
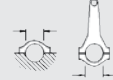
[11] Nitridé

[11] Nitrurato

[11] Nitrurado

									
BE/PL	4	56.520/56.535	60.333/60.345	24.700	1.870	0.020/0.072	BS	1870CP	<b>71-4130/4</b> STD 0.25 0.50 0.75
MB/HL 1-4	4	76.187/76.200	80.586/80.607	24.990	2.172	0.042/0.100	BS	66571CP	<b>H1049/5</b> STD 0.25 0.50 0.75
MB/HL 5	1	76.187/76.200	80.586/80.607	31.950	2.172	0.042/0.100	BS	66572CPH	

Mot. → 1846776









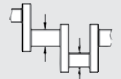

# FIAT GROUP

...Continued

**1286**

 **93.00**

**Diesel**

									
MB/HL 1-4	4	76.187/76.200	80.586/80.607	24.990	2.172	0.038/0.097	BS	66573CP	<b>H1094/5</b> STD 0.25
MB/HL 5	1	76.187/76.200	80.586/80.607	31.950	2.172	0.038/0.097	BS	66574CPH	

Mot.1846777 →

**66571CP**

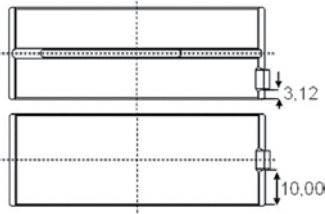

**66572CPH**

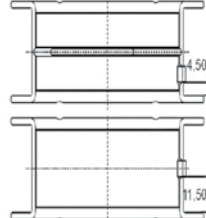

**66573CP**

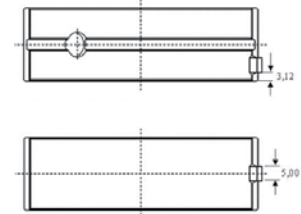

**66574CPH**

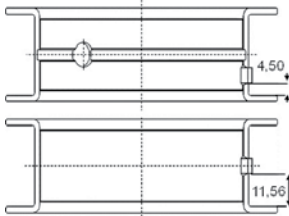

SE/PB	1	31.990/31.996	34.895/34.920	30.700			BS	66579YA	<b>55-4186</b> SEMI
-------	---	---------------	---------------	--------	--	--	----	---------	------------------------

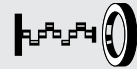

JJ519

NP067  50.00x70.00x10.00mm, FPM



JJ519

**1287**

 **93.00**

**Diesel**



8140.27R.2782	4 Cyl.	18:1	2499cc	70kW (96)PS	Turbocharged	TD1710	<b>645</b>
---------------	--------	------	--------	-------------	--------------	--------	------------



JJ519

NP067  50.00x70.00x10.00mm, FPM



JJ519



## 1288

 93.00

Diesel



8140.275.2700

4 Cyl.

18:1









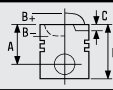
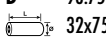
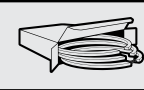

2499cc

76kW (103)PS

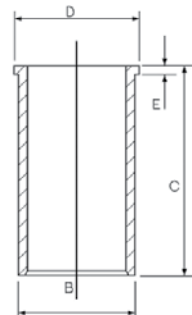
Turbocharged

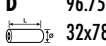
TD20421

647









 <p><b>87-245200-40</b> <b>87-245208-40</b></p> <p>STD 0.60mm</p> <p>A 58.75 B- 17.90 BØ 38.00 D 96.75  32x75</p> <p>RT</p>	 <p><b>08-245200-00</b> STD <b>08-245208-00</b> 0.60mm</p> <p>3.00  CR P 2.00  P 3.00  CR P</p>	 <p><b>14-021371-00 D</b> B 96.01 C 171.00 D 98.92 E 5.00 <b>14-021372-00 D</b> B 96.05 C 171.00 D 98.92 E 5.00 <b>14-021373-00 D</b> B 96.17 C 171.00 D 98.92 E 5.00 <b>14-021480-00 DH [11]</b> B 97.04 C 171.00 D 100.00 E 5.00</p> 	
<p><b>87-245200-50</b> <b>87-245208-50</b></p> <p>STD 0.60mm</p> <p>A 58.75 B- 17.90 BØ 38.00 D 96.75  32x78</p> <p>AK NB RT</p>	<p><b>08-245200-00</b> STD <b>08-245208-00</b> 0.60mm</p> <p>3.00  CR P 2.00  P 3.00  CR P</p>		

[11] Nitrided

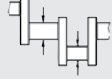
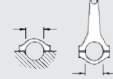
[11] Nitridé

[11] Nitrurato

[11] Nitrurado

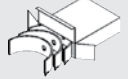
									
BE/PL	4	56.520/56.535	60.333/60.345	24.700	1.870	0.020/0.072	BS	1870CP	<b>71-4130/4</b> STD 0.25 0.50 0.75
MB/HL 1-4	4	76.187/76.200	80.586/80.607	24.990	2.172	0.042/0.100	BS	66571CP	<b>H1049/5</b> STD 0.25 0.50 0.75
MB/HL 5	1	76.187/76.200	80.586/80.607	31.950	2.172	0.042/0.100	BS	66572CPH	

Mot. → 1846776

**1288**

 **93.00**

**Diesel**

MB/HL 1-4	4	76.187/76.200	80.586/80.607	24.990	2.172	0.038/0.097	BS	66573CP	<b>H1094/5</b> STD 0.25
MB/HL 5	1	76.187/76.200	80.586/80.607	31.950	2.172	0.038/0.097	BS	66574CPH	

**Mot.1846777** →

**66571CP**

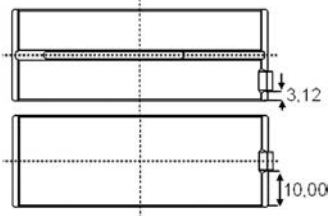

**66572CPH**

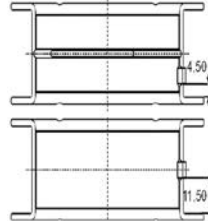

**66573CP**

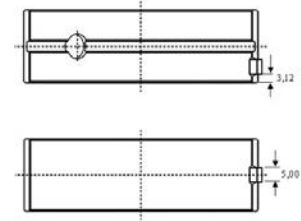

**66574CPH**

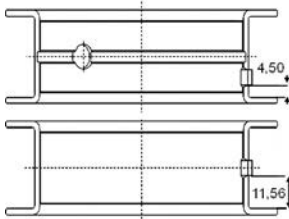

SE/PB	1	31.990/31.996	34.895/34.920	30.700			BS	66579YA	<b>55-4186</b> SEMI
-------	---	---------------	---------------	--------	--	--	----	---------	------------------------







**JJ100**  
(Cork)  
**JJ519**



**JJ100**

**JJ519**

**NA5055**  70.00x90.00x10.00mm, FPM  
**NP067**  50.00x70.00x10.00mm, FPM  
**NF883**  114.00x177.00x13.00mm, FPM  
**NF885**  70.00x179.00x16.00mm, FPM  
**NF886**  100.00x179.00x15.80mm, FPM

## 1289

### 93.00

### Diesel



8140.275.2801

4 Cyl.

18:1







2499cc

76kW (103)PS

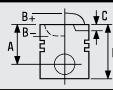
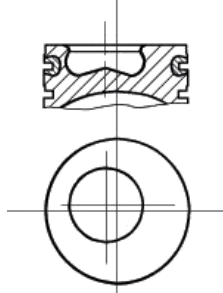
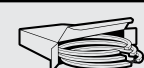
Turbocharged

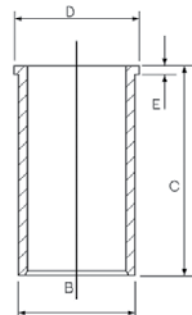
TD20419

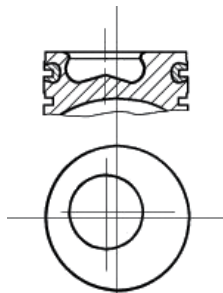
650









 <p><b>87-245200-40</b> <b>87-245208-40</b></p> <p>STD 0.60mm</p> <p>A 58.75 B- 17.90 BØ 38.00 D 96.75 E 32x75</p> <p>RT</p> 	 <p><b>08-245200-00</b> STD <b>08-245208-00</b> 0.60mm</p> <p>3.00 CR P 2.00 P 3.00 CR P</p> 	 <p><b>14-021371-00 D</b> B 96.01 C 171.00 D 98.92 E 5.00 <b>14-021372-00 D</b> B 96.05 C 171.00 D 98.92 E 5.00 <b>14-021373-00 D</b> B 96.17 C 171.00 D 98.92 E 5.00 <b>14-021480-00 DH [11]</b> B 97.04 C 171.00 D 100.00 E 5.00</p> 	
<p><b>87-245200-50</b> <b>87-245208-50</b></p> <p>STD 0.60mm</p> <p>A 58.75 B- 17.90 BØ 38.00 D 96.75 E 32x78</p> <p>AK NB RT</p> 	<p><b>08-245200-00</b> STD <b>08-245208-00</b> 0.60mm</p> <p>3.00 CR P 2.00 P 3.00 CR P</p> 		

[11] Nitrided

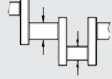
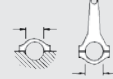
[11] Nitridé

[11] Nitrurato

[11] Nitrurado

									
BE/PL	4	56.520/56.535	60.333/60.345	24.700	1.870	0.020/0.072	BS	1870CP	<b>71-4130/4</b> STD 0.25 0.50 0.75
MB/HL 1-4	4	76.187/76.200	80.586/80.607	24.990	2.172	0.042/0.100	BS	66571CP	<b>H1049/5</b> STD 0.25 0.50 0.75
MB/HL 5	1	76.187/76.200	80.586/80.607	31.950	2.172	0.042/0.100	BS	66572CPH	

Mot. → 1846776

## 1289

 93.00

**Diesel**

MB/HL 1-4	4	76.187/76.200	80.586/80.607	24.990	2.172	0.038/0.097	BS	66573CP	<b>H1094/5</b> STD 0.25
MB/HL 5	1	76.187/76.200	80.586/80.607	31.950	2.172	0.038/0.097	BS	66574CPH	

Mot.1846777→

**66571CP**

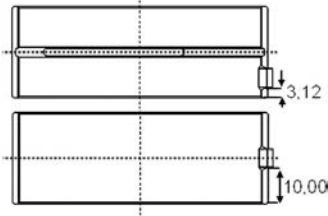

**66572CPH**

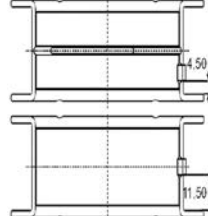

**66573CP**

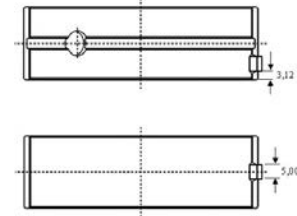

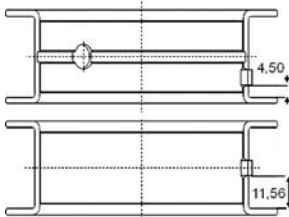

**66574CPH**



SE/PB	1	31.990/31.996	34.895/34.920	30.700			BS	66579YA	<b>55-4186</b> SEMI
-------	---	---------------	---------------	--------	--	--	----	---------	------------------------



**NA5055**  70.00x90.00x10.00mm, FPM  
**NF853**  100.00x118.00x10.00mm, FPM  
**NP067**  50.00x70.00x10.00mm, FPM

## 1290

 93.00

**Diesel**



<b>8140.27S.3700 Euro I</b>	4 Cyl.	18.5:1	2499cc	<b>77kW (105)PS</b>	<b>Turbocharged</b>	<b>TD20152</b>
<b>8140.47R.2210</b>	4 Cyl.	18.5:1	2499cc	<b>80kW (110)PS</b>	<b>Turbo Intercooled</b>	<b>TD6811 659</b>

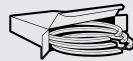
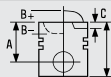

**87-520200-00**

STD

A 58.75  
 B- 18.40  
 BØ 38.00  
 D 96.75  
 32x78

AK KK NB RT

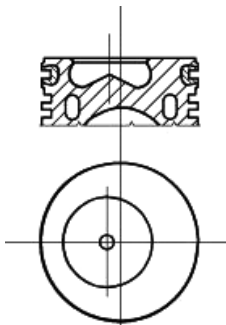

**08-520200-00**

STD

3.00  CR  
 2.00  P  
 3.00  CR P

**14-021371-00 D**

B 96.01 C 171.00 D 98.92 E 5.00  
**14-021372-00 D**  
 B 96.05 C 171.00 D 98.92 E 5.00  
**14-021373-00 D**  
 B 96.17 C 171.00 D 98.92 E 5.00  
**14-021480-00 DH [11]**  
 B 97.04 C 171.00 D 100.00 E 5.00

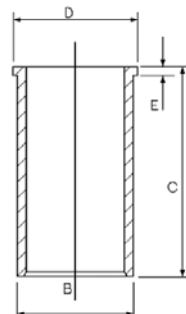

[11] Nitrided









[11] Nitridé

[11] Nitrurato

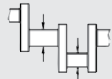
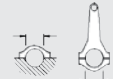
[11] Nitrurado

...Continued

**1290**  **93.00 Diesel**

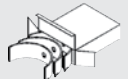
									
BE/PL	4	56.520/56.535	60.333/60.345	24.700	1.870	0.020/0.072	BS	1870CP	<b>71-4130/4</b> STD 0.25 0.50 0.75
BE/PL	4	56.520/56.535	60.333/60.345	24.700	1.870	0.020/0.070	BS	66575CP	<b>71-4185/4</b> STD 0.25 0.50 0.75

**1870CP**

**66575CP**

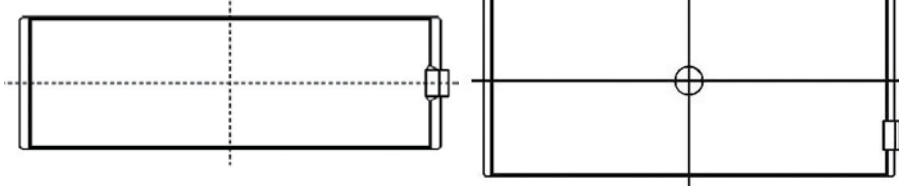

MB/HL 1-4	4	76.187/76.200	80.586/80.607	24.990	2.172	0.042/0.100	BS	66571CP	<b>H1049/5</b> STD 0.25 0.50 0.75
MB/HL 5	1	76.187/76.200	80.586/80.607	31.950	2.172	0.042/0.100	BS	66572CPH	
MB/HL 1-4	4	76.187/76.200	80.586/80.607	24.990	2.172	0.038/0.097	BS	66573CP	<b>H1094/5</b> STD 0.25
MB/HL 5	1	76.187/76.200	80.586/80.607	31.950	2.172	0.038/0.097	BS	66574CPH	

**66571CP**

**66572CPH**

**66573CP**

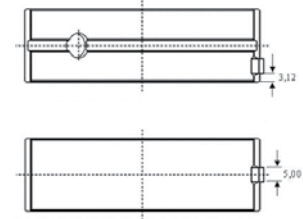
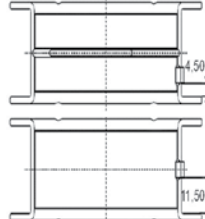
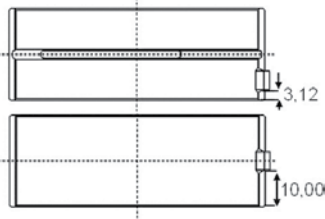

**66574CPH**

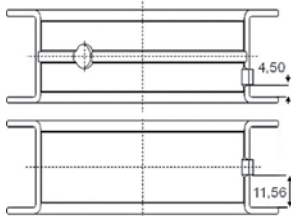

SE/PB	1	31.990/31.996	34.895/34.920	30.700			BS	66579YA	<b>55-4186</b> SEMI
-------	---	---------------	---------------	--------	--	--	----	---------	------------------------

## 1291

 93.00

**Diesel**



8140.47.2700 Euro 1

4 Cyl.

18:1

2499cc

85kW (116)PS

Turbocharged

TD1711

652

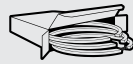
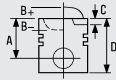

**87-520200-00**

STD

A 58.75  
B- 18.40  
BØ 38.00  
D 96.75  
 32x78

AK KK NB RT

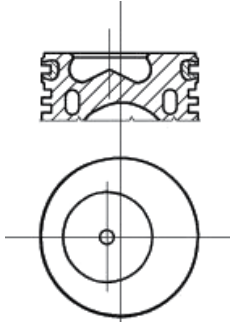

**08-520200-00**

STD

3.00  CR  
2.00  P  
3.00  CR P

**14-021371-00 D**

B 96.01 C 171.00 D 98.92 E 5.00

**14-021372-00 D**

B 96.05 C 171.00 D 98.92 E 5.00

**14-021373-00 D**

B 96.17 C 171.00 D 98.92 E 5.00

**14-021480-00 DH [11]**

B 97.04 C 171.00 D 100.00 E 5.00

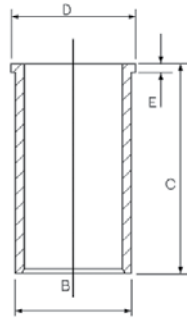











[11] Nitrided

[11] Nitridé









[11] Nitratato

[11] Niturado

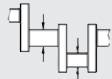
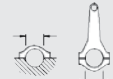
									
BE/PL	4	56.520/56.535	60.333/60.345	24.700	1.870	0.020/0.072	BS	1870CP	<b>71-4130/4</b> STD 0.25 0.50 0.75
MB/HL 1-4	4	76.187/76.200	80.586/80.607	24.990	2.172	0.042/0.100	BS	66571CP	<b>H1049/5</b> STD 0.25 0.50 0.75
MB/HL 5	1	76.187/76.200	80.586/80.607	31.950	2.172	0.042/0.100	BS	66572CPH	
<b>→12/92</b>									
MB/HL 1-4	4	76.187/76.200	80.586/80.607	24.990	2.172	0.038/0.097	BS	66573CP	<b>H1094/5</b> STD 0.25
MB/HL 5	1	76.187/76.200	80.586/80.607	31.950	2.172	0.038/0.097	BS	66574CPH	
<b>01/93→08/95</b>									

...Continued

**1291**  **93.00** Diesel

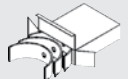
									
MB/HL 5	1	86.182/86.208	90.588/90.614	30.950	2.164	0.052/0.129	BS	4691CPH	<b>H1104/5</b> STD 0.25 0.50
MB/HL 1-4	4	80.182/80.208	84.588/84.614	23.800	2.164	0.052/0.129	BS	4692CP	



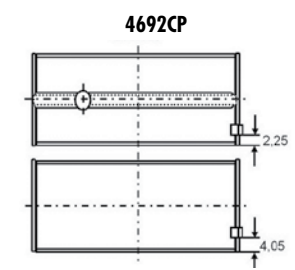
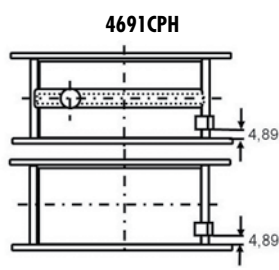
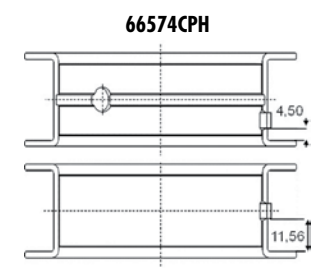
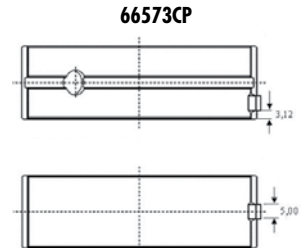
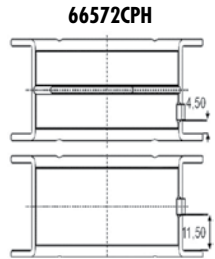
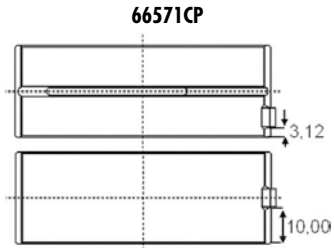

09/95 →

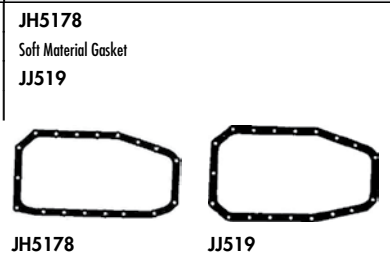
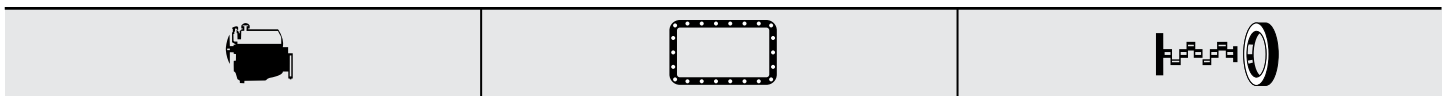

SE/PB	1	31.990/31.996	34.895/34.920	30.700			BS	66579YA	<b>55-4186</b> SEMI
-------	---	---------------	---------------	--------	--	--	----	---------	------------------------

Mot.344183 →



- NP067**  50.00x70.00x10.00mm, FPM
- NF883**  114.00x177.00x13.00mm, FPM
- NF885**  70.00x179.00x16.00mm, FPM
- NF886**  100.00x179.00x15.80mm, FPM

## 1292

93.00

**Diesel**



8140.47.2711 Euro 1

4 Cyl.

18:1

2499cc

85kW (116)PS

Turbocharged

TD1712

641

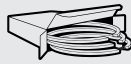
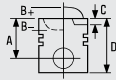

87-520200-00

STD

A 58.75  
B- 18.40  
BØ 38.00  
D 96.75  
 32x78

AK KK NB RT

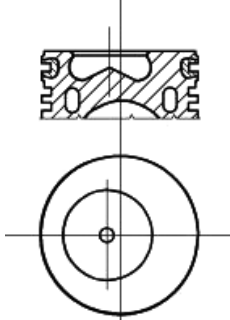

08-520200-00

STD

3.00 CR  
2.00 P  
3.00 CR P

14-021371-00 D

B 96.01 C 171.00 D 98.92 E 5.00

14-021372-00 D

B 96.05 C 171.00 D 98.92 E 5.00

14-021373-00 D

B 96.17 C 171.00 D 98.92 E 5.00

14-021480-00 DH [11]

B 97.04 C 171.00 D 100.00 E 5.00

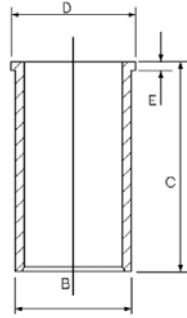

[11] Nitrided

[11] Nitridé

[11] Niturato

[11] Niturado



JH5178

Soft Material Gasket

JJ519

NF853 100.00x118.00x10.00mm, FPM



JH5178



JJ519

## 1293

93.00

**Diesel**



8140.47.2721 Euro 1

4 Cyl.

18:1

2499cc

85kW (116)PS

Turbocharged

TD1713

653

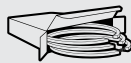
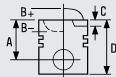

87-520200-00

STD

A 58.75  
B- 18.40  
BØ 38.00  
D 96.75  
 32x78

AK KK NB RT

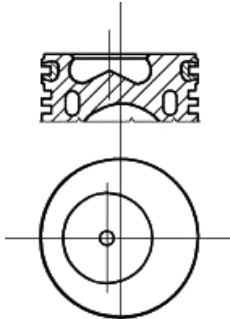

08-520200-00

STD

3.00 CR  
2.00 P  
3.00 CR P

14-021371-00 D

B 96.01 C 171.00 D 98.92 E 5.00

14-021372-00 D

B 96.05 C 171.00 D 98.92 E 5.00

14-021373-00 D

B 96.17 C 171.00 D 98.92 E 5.00

14-021480-00 DH [11]

B 97.04 C 171.00 D 100.00 E 5.00

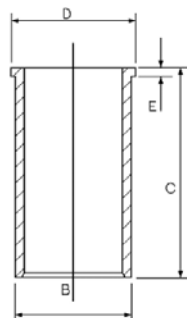

[11] Nitrided

[11] Nitridé









[11] Niturato

[11] Niturado

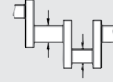
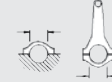

...Continued

**1293**  **93.00 Diesel**

									
BE/PL	4	56.520/56.535	60.333/60.345	24.700	1.870	0.020/0.072	BS	1870CP	<b>71-4130/4</b> STD 0.25 0.50 0.75
MB/HL 1-4	4	76.187/76.200	80.586/80.607	24.990	2.172	0.042/0.100	BS	66571CP	<b>H1049/5</b> STD 0.25 0.50 0.75
MB/HL 5	1	76.187/76.200	80.586/80.607	31.950	2.172	0.042/0.100	BS	66572CPH	
→12/92									
MB/HL 1-4	4	76.187/76.200	80.586/80.607	24.990	2.172	0.038/0.097	BS	66573CP	<b>H1094/5</b> STD 0.25
MB/HL 5	1	76.187/76.200	80.586/80.607	31.950	2.172	0.038/0.097	BS	66574CPH	
01/93 → 08/95									
MB/HL 5	1	86.182/86.208	90.588/90.614	30.950	2.164	0.052/0.129	BS	4691CPH	<b>H1104/5</b> STD 0.25 0.50
MB/HL 1-4	4	80.182/80.208	84.588/84.614	23.800	2.164	0.052/0.129	BS	4692CP	
09/95 →									

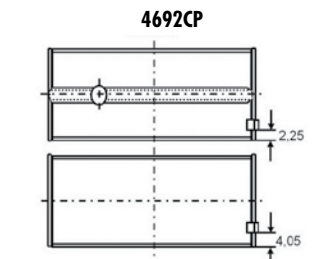
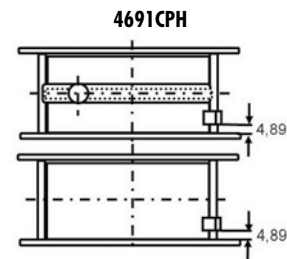
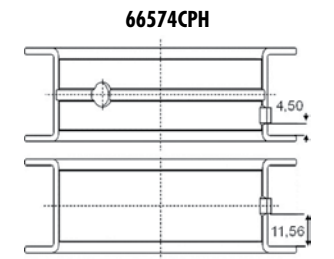
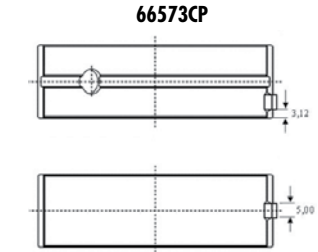
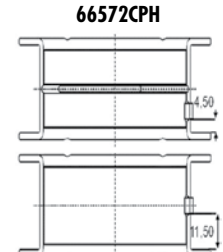
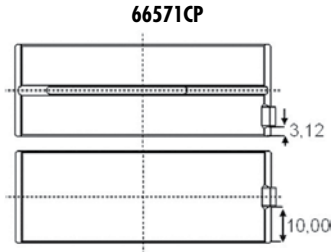

SE/PB	1	31.990/31.996	34.895/34.920	30.700			BS	66579YA	<b>55-4186</b> SEMI
-------	---	---------------	---------------	--------	--	--	----	---------	------------------------

Mot.344183 →

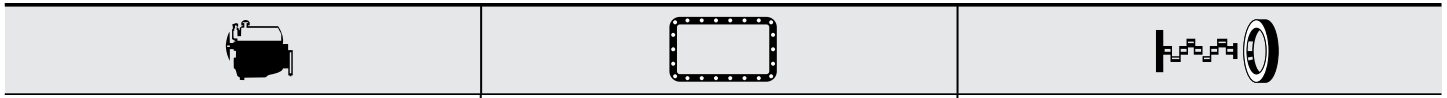

**JH5178**  
Soft Material Gasket  
**JJ519**



JH5178

JJ519

**NF853**  T00.00x118.00x10.00mm, FPM

## 1294

 93.00

**Diesel**



8140.47.2785 Euro 1

4 Cyl.

18:1

2499cc

85kW (116)PS

Turbocharged

TD1715

654

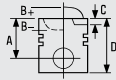

87-520200-00

STD

A 58.75  
B- 18.40  
BØ 38.00  
D 96.75  
 32x78

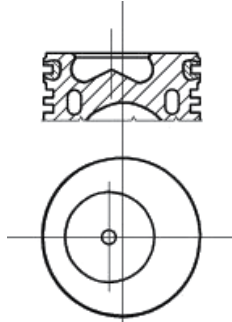

08-520200-00

STD

3.00  CR  
2.00  P  
3.00  CR P

14-021371-00 D

B 96.01 C 171.00 D 98.92 E 5.00

14-021372-00 D

B 96.05 C 171.00 D 98.92 E 5.00

14-021373-00 D

B 96.17 C 171.00 D 98.92 E 5.00

14-021480-00 DH [11]

B 97.04 C 171.00 D 100.00 E 5.00

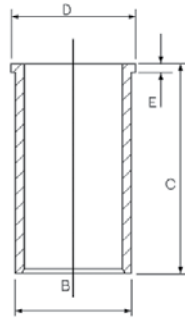











AK KK NB RT

[11] Nitrided

[11] Nitridé









[11] Nitratato

[11] Niturado

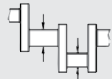
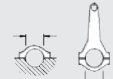
									
BE/PL	4	56.520/56.535	60.333/60.345	24.700	1.870	0.020/0.072	BS	1870CP	<b>71-4130/4</b> STD 0.25 0.50 0.75
MB/HL 1-4	4	76.187/76.200	80.586/80.607	24.990	2.172	0.042/0.100	BS	66571CP	<b>H1049/5</b> STD 0.25 0.50 0.75
MB/HL 5	1	76.187/76.200	80.586/80.607	31.950	2.172	0.042/0.100	BS	66572CPH	
<b>→12/92</b>									
MB/HL 1-4	4	76.187/76.200	80.586/80.607	24.990	2.172	0.038/0.097	BS	66573CP	<b>H1094/5</b> STD 0.25
MB/HL 5	1	76.187/76.200	80.586/80.607	31.950	2.172	0.038/0.097	BS	66574CPH	
<b>01/93→08/95</b>									

...Continued

**1294**  **93.00 Diesel**

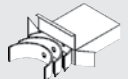
									
MB/HL 5	1	86.182/86.208	90.588/90.614	30.950	2.164	0.052/0.129	BS	4691CPH	<b>H1104/5</b> STD 0.25 0.50
MB/HL 1-4	4	80.182/80.208	84.588/84.614	23.800	2.164	0.052/0.129	BS	4692CP	

09/95 →

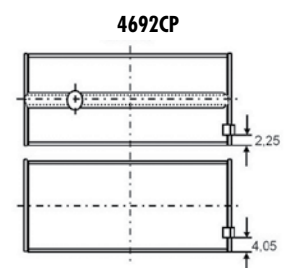
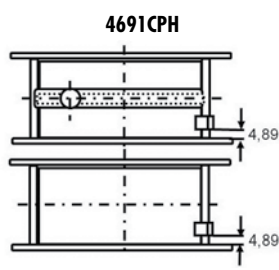
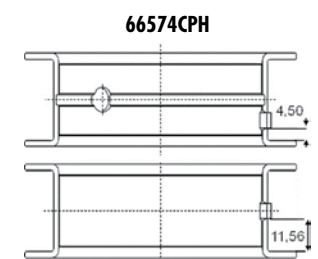
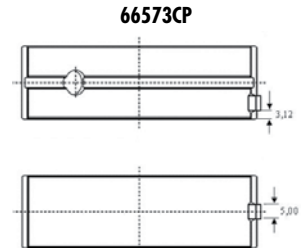
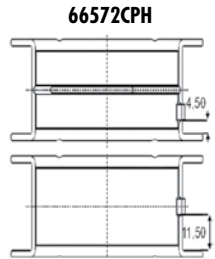
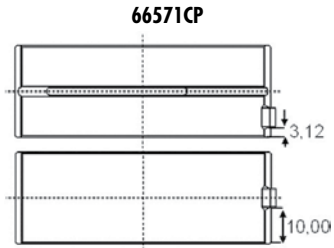

SE/PB	1	31.990/31.996	34.895/34.920	30.700			BS	66579YA	<b>55-4186</b> SEMI
-------	---	---------------	---------------	--------	--	--	----	---------	------------------------

Mot.344183 →

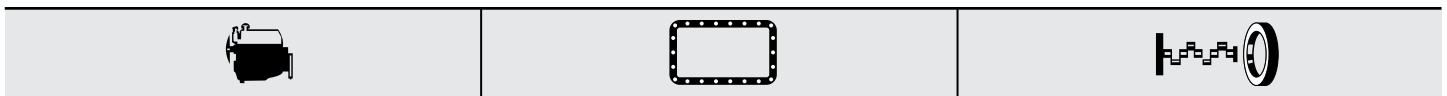

**JJ100**  
(Cork)



**JJ100**

**NP067**  50.00x70.00x10.00mm, FPM

## 1295

 93.00

**Diesel**



8140.47.3700 Euro 1

4 Cyl.

18.5:1

2499cc

85kW (116)PS

Turbo Intercooled

TD20477

656

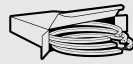
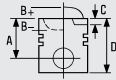

**87-520200-00**

STD

A 58.75  
B- 18.40  
BØ 38.00  
D 96.75  
 32x78

AK KK NB RT

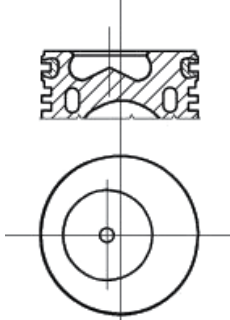

**08-520200-00**

STD

3.00  CR  
2.00  P  
3.00  CR P

**14-021371-00 D**

B 96.01 C 171.00 D 98.92 E 5.00

**14-021372-00 D**

B 96.05 C 171.00 D 98.92 E 5.00

**14-021373-00 D**

B 96.17 C 171.00 D 98.92 E 5.00

**14-021480-00 DH [11]**

B 97.04 C 171.00 D 100.00 E 5.00

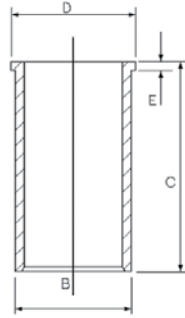





[11] Nitrided

[11] Nitridé

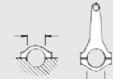
[11] Niturato

[11] Niturado

									
BE/PL	4	56.520/56.535	60.333/60.345	24.700	1.870	0.020/0.072	BS	1870CP	<b>71-4130/4</b> STD 0.25 0.50 0.75
BE/PL	4	56.520/56.535	60.333/60.345	24.700	1.870	0.020/0.070	BS	66575CP	<b>71-4185/4</b> STD 0.25 0.50 0.75





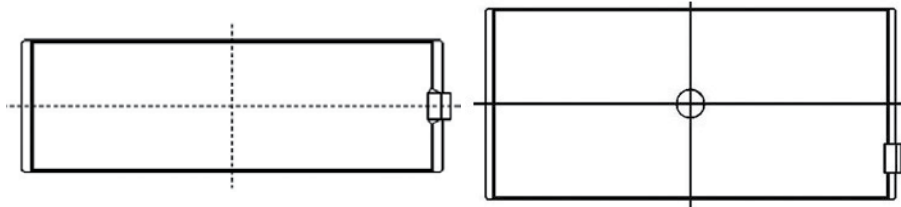



1870CP

66575CP

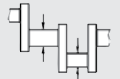
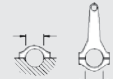

...Continued

**1295**  **93.00** **Diesel**

									
MB/HL 1-4	4	76.187/76.200	80.586/80.607	24.990	2.172	0.042/0.100	BS	66571CP	<b>H1049/5</b> STD 0.25 0.50 0.75
MB/HL 5	1	76.187/76.200	80.586/80.607	31.950	2.172	0.042/0.100	BS	66572CPH	
MB/HL 1-4	4	76.187/76.200	80.586/80.607	24.990	2.172	0.038/0.097	BS	66573CP	<b>H1094/5</b> STD 0.25
MB/HL 5	1	76.187/76.200	80.586/80.607	31.950	2.172	0.038/0.097	BS	66574CPH	

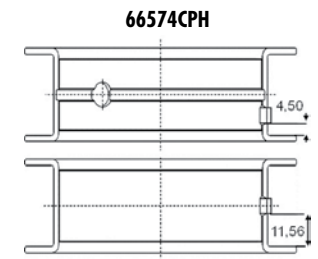
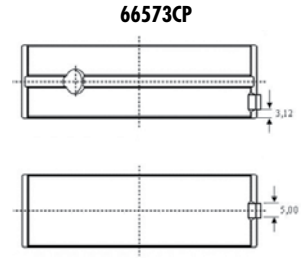
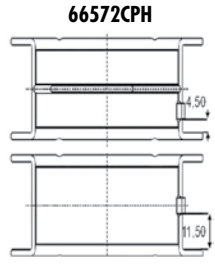
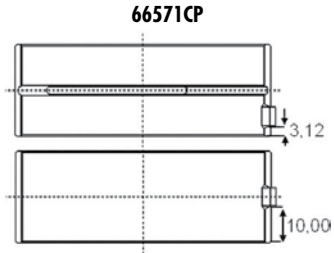

SE/PB	1	31.990/31.996	34.895/34.920	30.700			BS	66579YA	<b>55-4186</b> SEMI
-------	---	---------------	---------------	--------	--	--	----	---------	------------------------

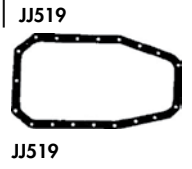
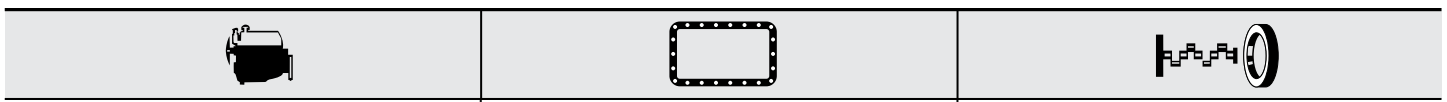

NP067  50.00x70.00x10.00mm, FPM









## 1296

 93.00

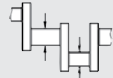
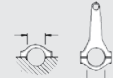
**Diesel**

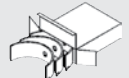

8140.47.3711 Euro 1	4 Cyl.	18.5:1	2499cc	85kW (116)PS	Turbo Intercooled	TD26005	657
8140.47.3721 Euro 1	4 Cyl.	18.5:1	2499cc	85kW (116)PS	Turbo Intercooled	TD26006	639
8140.47.3731 Euro 1	4 Cyl.	18.5:1	2499cc	85kW (116)PS	Turbo Intercooled	TD26007	
8140.47B.3790 Euro 1	4 Cyl.	18.5:1	2499cc	78-83kW (106-113)PS	Turbo Intercooled	TD26008	639
8140.47B.3795 Euro 1	4 Cyl.	18.5:1	2499cc	78-83kW (106-113)PS	Turbo Intercooled	TD26009	639
8140.47R.2795	4 Cyl.	18.5:1	2499cc	80kW (109)PS	Turbo Intercooled	TD26010	639
8144.97.2200	4 Cyl.	22:1	2499cc	86-87kW (117-118)PS	Turbo Intercooled	TD1062	
8144.97.2400	4 Cyl.	21:1	2499cc	83-87kW (113-118)PS	Turbo Intercooled	TD22318	
8144.97.2500	4 Cyl.	22.5:1	2500cc	85kW (118)PS	Turbo Intercooled	TD1063	

									
BE/PL	4	56.520/56.535	60.333/60.345	24.700	1.870	0.020/0.072	BS	1870CP	<b>71-4130/4</b> STD 0.25 0.50 0.75
BE/PL	4	56.520/56.535	60.333/60.345	24.700	1.870	0.020/0.070	BS	66575CP	<b>71-4185/4</b> STD 0.25 0.50 0.75

1870CP

66575CP

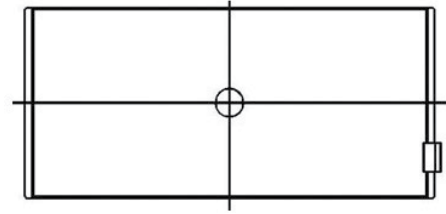
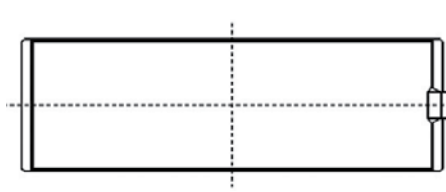

MB/HL 1-4	4	76.187/76.200	80.586/80.607	24.990	2.172	0.042/0.100	BS	66571CP	<b>H1049/5</b> STD 0.25 0.50 0.75
MB/HL 5	1	76.187/76.200	80.586/80.607	31.950	2.172	0.042/0.100	BS	66572CPH	
MB/HL 1-4	4	76.187/76.200	80.586/80.607	24.990	2.172	0.038/0.097	BS	66573CP	<b>H1094/5</b> STD 0.25
MB/HL 5	1	76.187/76.200	80.586/80.607	31.950	2.172	0.038/0.097	BS	66574CPH	

66571CP

66572CPH

66573CP

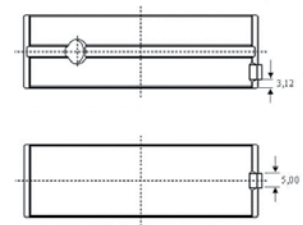
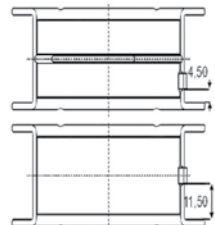
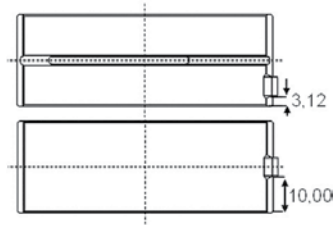

66574CPH

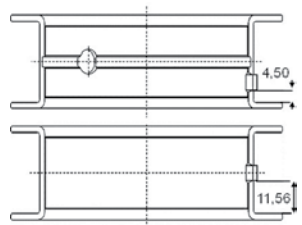

SE/PB	1	31.990/31.996	34.895/34.920	30.700			BS	66579YA	<b>55-4186</b> SEMI
-------	---	---------------	---------------	--------	--	--	----	---------	------------------------

## 1297

### 93.00

### Diesel



8140.47R      4 Cyl.      18:1      2499cc      80kW (109)PS      Turbocharged      TD7234      658

<b>87-520200-00</b> STD  <b>A</b> 58.75 <b>B-</b> 18.40 <b>BØ</b> 38.00 <b>D</b> 96.75 32x78  <b>AK KK NB RT</b>		<b>08-520200-00</b> STD  3.00  CR 2.00  P 3.00  CR P	<b>14-021371-00 D</b> <b>B</b> 96.01 <b>C</b> 171.00 <b>D</b> 98.92 <b>E</b> 5.00 <b>14-021372-00 D</b> <b>B</b> 96.05 <b>C</b> 171.00 <b>D</b> 98.92 <b>E</b> 5.00 <b>14-021373-00 D</b> <b>B</b> 96.17 <b>C</b> 171.00 <b>D</b> 98.92 <b>E</b> 5.00 <b>14-021480-00 DH</b> [11] <b>B</b> 97.04 <b>C</b> 171.00 <b>D</b> 100.00 <b>E</b> 5.00  

[11] Nitrided      [11] Nitridé      [11] Nitrurato      [11] Nitrado

BE/PL	4	56.520/56.535	60.333/60.345	24.700	1.870	0.020/0.072	BS	1870CP	<b>71-4130/4</b> STD 0.25 0.50 0.75
MB/HL 1-4	4	76.187/76.200	80.586/80.607	24.990	2.172	0.042/0.100	BS	66571CP	<b>H1049/5</b> STD 0.25 0.50 0.75
MB/HL 5	1	76.187/76.200	80.586/80.607	31.950	2.172	0.042/0.100	BS	66572CPH	

**Mot. → 1846776**

MB/HL 1-4	4	76.187/76.200	80.586/80.607	24.990	2.172	0.038/0.097	BS	66573CP	<b>H1094/5</b> STD 0.25
MB/HL 5	1	76.187/76.200	80.586/80.607	31.950	2.172	0.038/0.097	BS	66574CPH	

**Mot. 1846777 →**

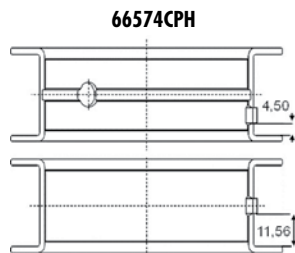
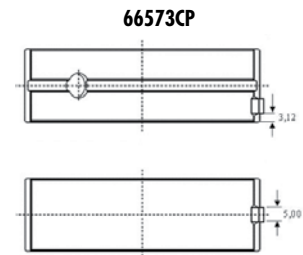
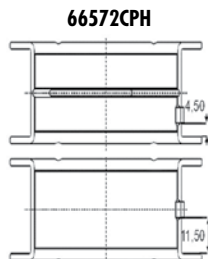
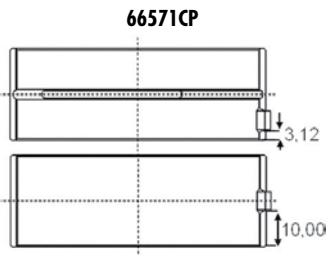



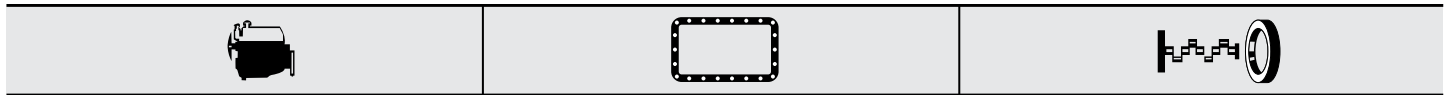

SE/PB	1	31.990/31.996	34.895/34.920	30.700			BS	66579YA	<b>55-4186</b> SEMI
-------	---	---------------	---------------	--------	--	--	----	---------	------------------------

**1297**  **93.00** **Diesel**





**JH5178**  
Soft Material Gasket  
**JJ519**

**NP067**  50.00x70.00x10.00mm, FPM  
**NF883**  114.00x177.00x13.00mm, FPM  
**NF885**  70.00x179.00x16.00mm, FPM  
**NF886**  100.00x179.00x15.80mm, FPM



JH5178

JJ519

**1298**  **93.00** **Diesel** 

8140.47R.2790 4 Cyl. 18.5:1 2499cc 76-80kW (103-109)PS Turbo Intercooled TD1716 660

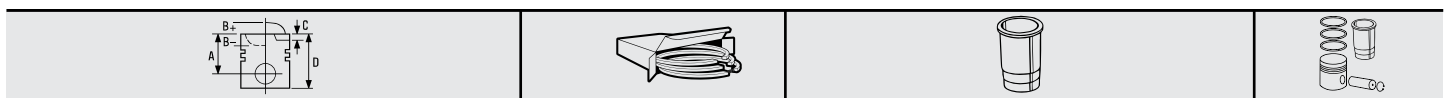

87-520200-00

STD

A 58.75  
B- 18.40  
BØ 38.00  
D 96.75  
 32x78

AK KK NB RT

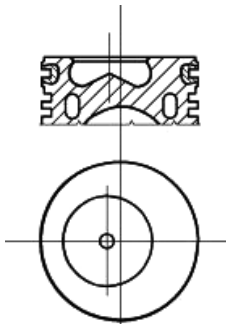

08-520200-00

STD

3.00  CR  
2.00  P  
3.00  CR P

14-021371-00 D

B 96.01 C 171.00 D 98.92 E 5.00

14-021372-00 D

B 96.05 C 171.00 D 98.92 E 5.00

14-021373-00 D

B 96.17 C 171.00 D 98.92 E 5.00

14-021480-00 DH [11]

B 97.04 C 171.00 D 100.00 E 5.00

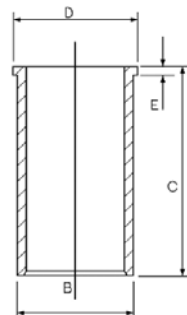

[11] Nitrided

[11] Nitridé

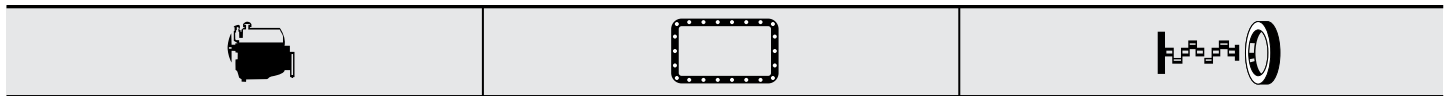

[11] Niturato

[11] Niturado



 ES381

**JH5178**  
Soft Material Gasket  
**JJ519**

**NP067**  50.00x70.00x10.00mm, FPM  
**NF883**  114.00x177.00x13.00mm, FPM  
**NF885**  70.00x179.00x16.00mm, FPM



JH5178

JJ519



## 1299

## 93.00

## Diesel



8140.475 Euro I

4 Cyl.

18.5:1

2499cc

85kW (116)PS

Turbo Intercooled

TD20453

661

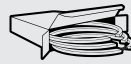
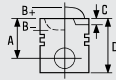

87-520200-00

STD

A 58.75  
B- 18.40  
BØ 38.00  
D 96.75  
32x78

AK KK NB RT

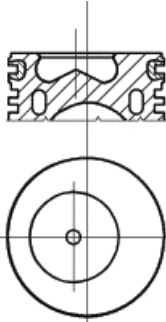

08-520200-00

STD

3.00 CR  
2.00 P  
3.00 CR P

14-021371-00 D

B 96.01 C 171.00 D 98.92 E 5.00

14-021372-00 D

B 96.05 C 171.00 D 98.92 E 5.00

14-021373-00 D

B 96.17 C 171.00 D 98.92 E 5.00

14-021480-00 DH [11]

B 97.04 C 171.00 D 100.00 E 5.00

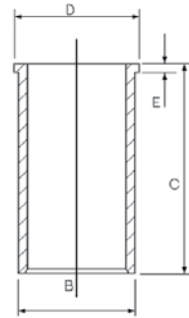

[11] Nitrided

[11] Nitridé

[11] Nitratato

[11] Niturado

BE/PL	4	56.520/56.535	60.333/60.345	24.700	1.870	0.020/0.072	BS	1870CP	71-4130/4 STD 0.25 0.50 0.75
MB/HL 1-4	4	76.187/76.200	80.586/80.607	24.990	2.172	0.042/0.100	BS	66571CP	H1049/5 STD 0.25 0.50 0.75
MB/HL 5	1	76.187/76.200	80.586/80.607	31.950	2.172	0.042/0.100	BS	66572CPH	

Mot. → 1846776

MB/HL 1-4	4	76.187/76.200	80.586/80.607	24.990	2.172	0.038/0.097	BS	66573CP	H1094/5 STD 0.25
MB/HL 5	1	76.187/76.200	80.586/80.607	31.950	2.172	0.038/0.097	BS	66574CPH	

Mot. 1846777 →

66571CP

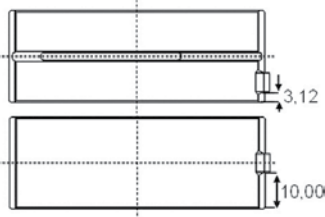

66572CPH

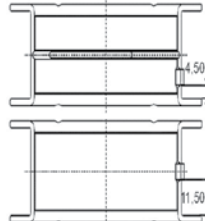

66573CP

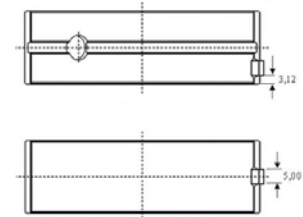



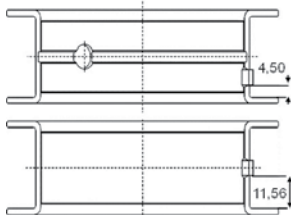



66574CPH



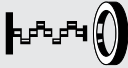

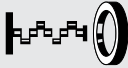
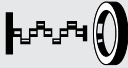
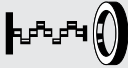





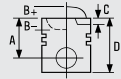

SE/PB	1	31.990/31.996	34.895/34.920	30.700			BS	66579YA	55-4186 SEMI
-------	---	---------------	---------------	--------	--	--	----	---------	-----------------

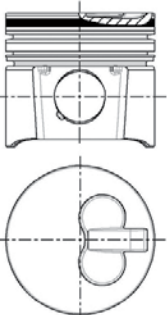
**1299**  **93.00** **Diesel**





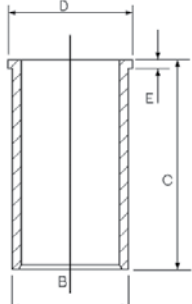



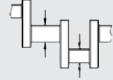

		
	<b>JJ100</b> (Cork)   <b>JJ100</b>	<b>NP067</b>  50.00x70.00x10.00mm, FPM <b>NF883</b>  114.00x177.00x13.00mm, FPM <b>NF885</b>  70.00x179.00x16.00mm, FPM

**1300**  **93.00** **Diesel** 

<b>8140.67.2700</b>	4 Cyl.	22:1	2499cc	<b>62kW</b> (85)PS	<b>TD6810</b>
<b>8140.67F.3701 Euro 2</b>	4 Cyl.	21:1	2499cc	<b>60kW</b> (82)PS	<b>TD26292</b>
<b>8140.67F.3710 Euro 2</b>	4 Cyl.	21:1	2499cc	<b>60kW</b> (82)PS	<b>TD26293</b>
<b>8140.67F.3711 Euro 2</b>	4 Cyl.	21:1	2499cc	<b>60kW</b> (82)PS	<b>TD26294</b>
<b>8140.67F.3713 Euro 2</b>	4 Cyl.	21:1	2499cc	<b>60kW</b> (82)PS	<b>TD26295</b>
<b>8140.67F.3721 Euro 2</b>	4 Cyl.	21:1	2499cc	<b>60kW</b> (82)PS	<b>TD26296</b>

 <b>87-425000-10</b> STD <b>87-425008-10</b> 0.60mm  <b>A</b> 54.00 <b>B-</b> 2.20 <b>D</b> 89.00  32x68 <b>HA RT</b>		 <b>08-425000-00</b> STD <b>08-425008-00</b> 0.60mm  <b>3.00</b>  CR P <b>2.00</b>  P <b>3.00</b>  CR P	 <b>14-021371-00 D</b> <b>B</b> 96.01 <b>C</b> 171.00 <b>D</b> 98.92 <b>E</b> 5.00 <b>14-021372-00 D</b> <b>B</b> 96.05 <b>C</b> 171.00 <b>D</b> 98.92 <b>E</b> 5.00 <b>14-021373-00 D</b> <b>B</b> 96.17 <b>C</b> 171.00 <b>D</b> 98.92 <b>E</b> 5.00 <b>14-021480-00 DH [11]</b> <b>B</b> 97.04 <b>C</b> 171.00 <b>D</b> 100.00 <b>E</b> 5.00  	
--	--	---	--	---

[11] Nitrided [11] Nitridé [11] Nitrurato [11] Nitrurado

									
BE/PL	4	56.520/56.535	60.333/60.345	24.700	1.870	0.020/0.072	BS	1870CP	<b>71-4130/4</b> STD 0.25 0.50 0.75
BE/PL	4	56.520/56.535	60.333/60.345	24.700	1.870	0.020/0.070	BS	66575CP	<b>71-4185/4</b> STD 0.25 0.50 0.75





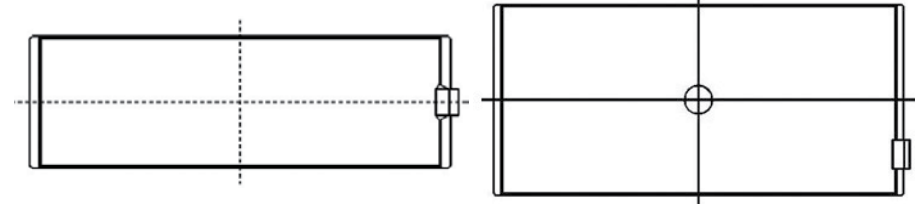





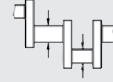

1870CP

66575CP





...Continued

**1300**  **93.00 Diesel**

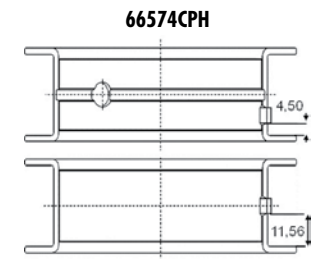
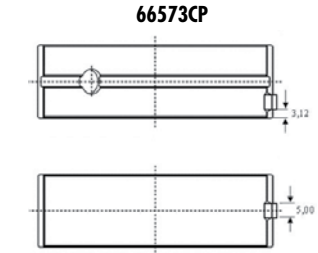
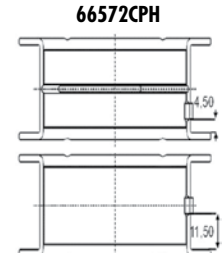
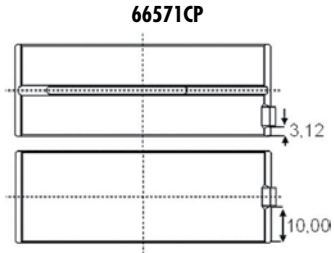







											
MB/HL 1-4	4	76.187/76.200	80.586/80.607	24.990	2.172	0.042/0.100	BS	66571CP	<b>H1049/5</b> STD 0.25 0.50 0.75		
MB/HL 5	1	76.187/76.200	80.586/80.607	31.950	2.172	0.042/0.100	BS	66572CPH			
MB/HL 1-4	4	76.187/76.200	80.586/80.607	24.990	2.172	0.038/0.097	BS	66573CP	<b>H1094/5</b> STD 0.25		
MB/HL 5	1	76.187/76.200	80.586/80.607	31.950	2.172	0.038/0.097	BS	66574CPH			

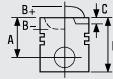
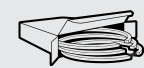

SE/PB	1	31.990/31.996	34.895/34.920	30.700			BS	66579YA	<b>55-4186</b> SEMI
-------	---	---------------	---------------	--------	--	--	----	---------	------------------------



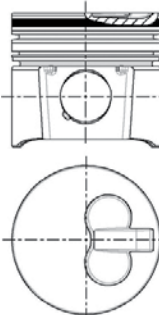

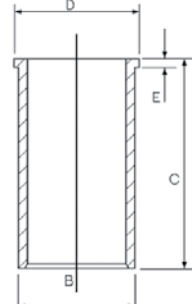

**1301**  **93.00 Diesel** 

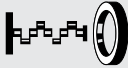

8140.67F.3700 Euro 2    4 Cyl.    21:1    2499cc    60-63kW (82-86)PS    TD20428    662

			
<p>87-425000-10 STD</p> <p>87-425008-10 0.60mm</p> <p>A 54.00</p> <p>B- 2.20</p> <p>D 89.00</p> <p> 32x68</p> <p>HA RT</p>	<p>08-425000-00 STD</p> <p>08-425008-00 0.60mm</p> <p>3.00  CR P</p> <p>2.00  P</p> <p>3.00  CR P</p>	<p>14-021371-00 D</p> <p>B 96.01 C 171.00 D 98.92 E 5.00</p> <p>14-021372-00 D</p> <p>B 96.05 C 171.00 D 98.92 E 5.00</p> <p>14-021373-00 D</p> <p>B 96.17 C 171.00 D 98.92 E 5.00</p> <p>14-021480-00 DH [11]</p> <p>B 97.04 C 171.00 D 100.00 E 5.00</p>	
			









[11] Nitrided    [11] Nitridé    [11] Nitrurato    [11] Nitrurado

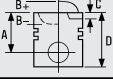
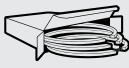



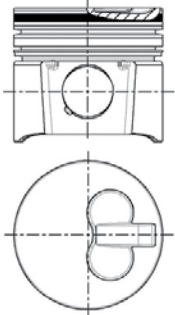

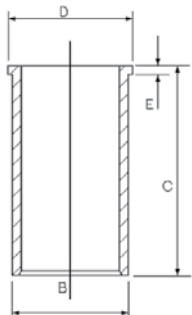

**1301**  **93.00 Diesel**



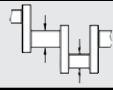



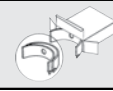
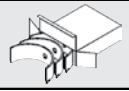

		
	<p><b>JJ519</b></p>  <p><b>JJ519</b></p>	<p><b>NP067</b>  50.00x70.00x10.00mm, FPM  <b>NF883</b>  114.00x177.00x13.00mm, FPM  <b>NF885</b>  70.00x179.00x16.00mm, FPM</p>

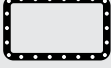
**1302**  **93.00 Diesel** 

8140.67F. Euro 2      4 Cyl.      21:1      2499cc      60kW (82)PS      TD7226      **663**

			
<p><b>87-425000-10</b> STD  <b>87-425008-10</b> 0.60mm  eng. →2573053</p> <p><b>A</b> 54.00  <b>B-</b> 2.20  <b>D</b> 89.00   32x68</p> <p><b>HA RT</b></p> 	<p><b>08-425000-00</b> STD  <b>08-425008-00</b> 0.60mm</p> <p>3.00  CR P  2.00  P  3.00  CR P</p>	<p><b>14-021371-00 D</b>  <b>B</b> 96.01    <b>C</b> 171.00    <b>D</b> 98.92    <b>E</b> 5.00  <b>14-021372-00 D</b>  <b>B</b> 96.05    <b>C</b> 171.00    <b>D</b> 98.92    <b>E</b> 5.00  <b>14-021373-00 D</b>  <b>B</b> 96.17    <b>C</b> 171.00    <b>D</b> 98.92    <b>E</b> 5.00  <b>14-021480-00 DH</b> [11]  <b>B</b> 97.04    <b>C</b> 171.00    <b>D</b> 100.00    <b>E</b> 5.00</p> 	
[11] Nitríded	[11] Nitríde	[11] Nitrurato	[11] Nitrurado

									
BE/PL	4	56.520/56.535	60.333/60.345	24.700	1.870	0.020/0.072	BS	1870CP	<b>71-4130/4</b> STD 0.25 0.50 0.75
MB/HL 5	1	86.182/86.208	90.588/90.614	30.950	2.164	0.052/0.129	BS	4691CPH	<b>H1104/5</b> STD 0.25 0.50
MB/HL 1-4	4	80.182/80.208	84.588/84.614	23.800	2.164	0.052/0.129	BS	4692CP	
SE/PB	1	31.990/31.996	34.895/34.920	30.700			BS	66579YA	<b>55-4186</b> SEMI

		
<p> <b>EW091</b></p>	<p><b>JH5178</b> Soft Material Gasket  <b>JJ519</b></p>   <p><b>JH5178</b>      <b>JJ519</b></p>	<p><b>NP067</b>  50.00x70.00x10.00mm, FPM  <b>NF883</b>  114.00x177.00x13.00mm, FPM  <b>NF885</b>  70.00x179.00x16.00mm, FPM</p>

## 1303

## 93.00

## Diesel



8140.97.2781

4 Cyl.

18:1

2499cc

68kW (92)PS

Turbo Intercooled

TD1717

664

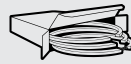
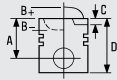

**08-245200-00** STD  
**08-245208-00** 0.60mm

3.00 CR P  
 2.00 P  
 3.00 CR P

**14-028930-00 D**  
**B 97.50 C 167.00 D 100.90 E 5.00**  
**14-028931-00 D**  
**B 97.58 C 167.00 D 100.90 E 5.00**  
**14-028932-00 D**  
**B 97.70 C 167.00 D 100.90 E 5.00**

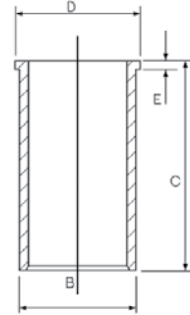

BE/PL	4	56.520/56.535	60.333/60.345	24.700	1.870	0.020/0.072	BS	1870CP	<b>71-4130/4</b> STD 0.25 0.50 0.75
MB/HL 1-4	4	76.187/76.200	80.586/80.607	24.990	2.172	0.042/0.100	BS	66571CP	<b>H1049/5</b> STD 0.25 0.50 0.75
MB/HL 5	1	76.187/76.200	80.586/80.607	31.950	2.172	0.042/0.100	BS	66572CPH	

Mot. → 1846776

MB/HL 1-4	4	76.187/76.200	80.586/80.607	24.990	2.172	0.038/0.097	BS	66573CP	<b>H1094/5</b> STD 0.25
MB/HL 5	1	76.187/76.200	80.586/80.607	31.950	2.172	0.038/0.097	BS	66574CPH	

Mot. 1846777 →

66571CP

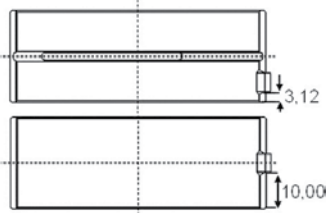

66572CPH

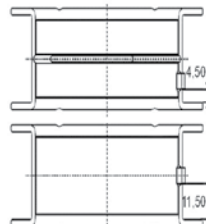

66573CP

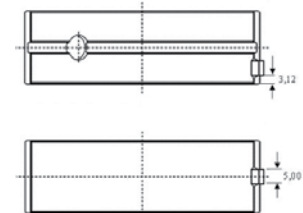



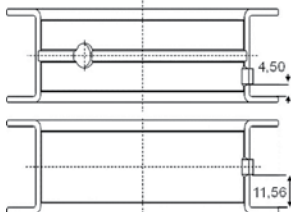

66574CPH







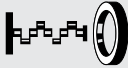





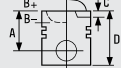
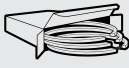





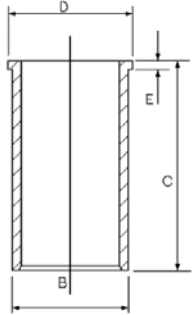

SE/PB	1	31.990/31.996	34.895/34.920	30.700			BS	66579YA	<b>55-4186</b> SEMI
-------	---	---------------	---------------	--------	--	--	----	---------	------------------------

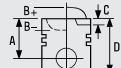
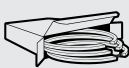
# FIAT GROUP

...Continued

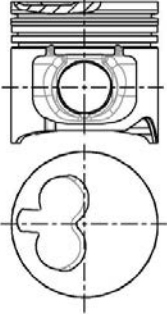
<b>1303</b>	 93.00	<b>Diesel</b>
		
	JJ519 	NF853  100.00x118.00x10.00mm, FPM

<b>1304</b>	 93.00	<b>Diesel</b>	
8140.97.2783	4 Cyl.	2499cc	Turbocharged <b>FM29100</b>
			
	<b>08-245200-00</b> STD <b>08-245208-00</b> 0.60mm  3.00  CR P 2.00  P 3.00  CR P	<b>14-028930-00 D</b> B 97.50 C 167.00 D 100.90 E 5.00 <b>14-028931-00 D</b> B 97.58 C 167.00 D 100.90 E 5.00 <b>14-028932-00 D</b> B 97.70 C 167.00 D 100.90 E 5.00  	

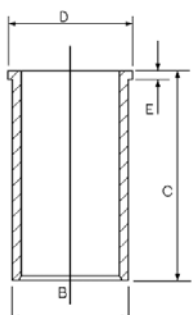
<b>1305</b>	 93.00	<b>Diesel</b>	
8144.67.220	4 Cyl.	22:1 2499cc	55kW (75)PS <b>TD147 666</b>
			
<b>87-783300-00</b> STD <b>87-783308-00</b> 0.60mm  A 54.00 B- 2.20 D 89.00  32x75  HA RT  	<b>08-783300-00</b> STD <b>08-783308-00</b> 0.60mm  3.00  CR P 2.00  P 3.00  CR P	<b>14-021280-00 DH [11]</b> B 97.03 C 167.00 D 100.00 E 5.00 <b>14-028930-00 D</b> B 97.50 C 167.00 D 100.90 E 5.00 <b>14-028931-00 D</b> B 97.58 C 167.00 D 100.90 E 5.00 <b>14-028932-00 D</b> B 97.70 C 167.00 D 100.90 E 5.00  	

[11] Nitrided









[11] Nitridé

[11] Niturato

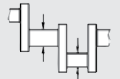
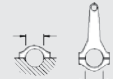
[11] Niturado

...Continued

**1305**  **93.00 Diesel**

									
BE/PL	4	56.520/56.535	60.333/60.345	24.700	1.870	0.020/0.072	BS	1870CP	<b>71-4130/4</b> STD 0.25 0.50 0.75
BE/PL	4	56.520/56.535	60.333/60.345	24.700	1.870	0.020/0.070	BS	66575CP	<b>71-4185/4</b> STD 0.25 0.50 0.75

**1870CP**

**66575CP**

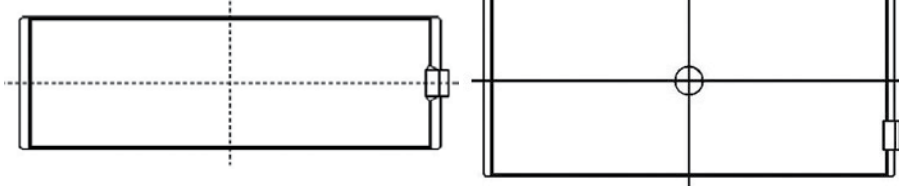

MB/HL 1-4	4	76.187/76.200	80.586/80.607	24.990	2.172	0.042/0.100	BS	66571CP	<b>H1049/5</b> STD 0.25 0.50 0.75
MB/HL 5	1	76.187/76.200	80.586/80.607	31.950	2.172	0.042/0.100	BS	66572CPH	
MB/HL 1-4	4	76.187/76.200	80.586/80.607	24.990	2.172	0.038/0.097	BS	66573CP	<b>H1094/5</b> STD 0.25
MB/HL 5	1	76.187/76.200	80.586/80.607	31.950	2.172	0.038/0.097	BS	66574CPH	

**66571CP**

**66572CPH**

**66573CP**

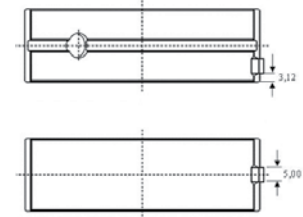
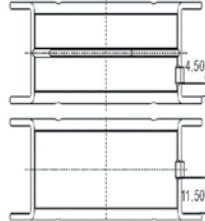
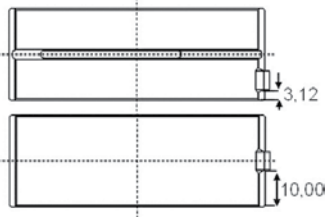

**66574CPH**

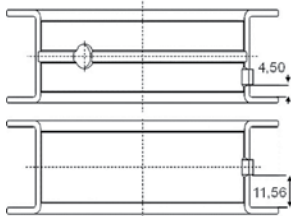

SE/PB	1	31.990/31.996	34.895/34.920	30.700			BS	66579YA	<b>55-4186</b> SEMI
-------	---	---------------	---------------	--------	--	--	----	---------	------------------------

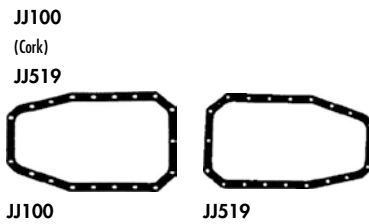
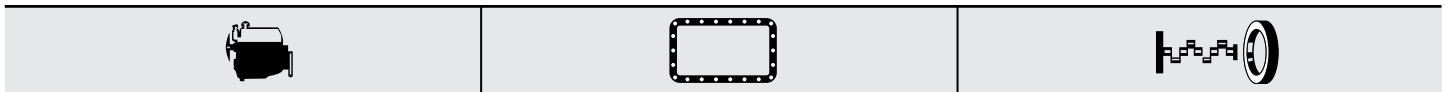

NF833  90.00x115.00x13.00mm, FPM

## 1306

 93.00

**Diesel**



8144.67.220

4 Cyl.

22:1

2499cc

55kW (75)PS

TD6797

665

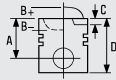

**87-783300-00**  
**87-783308-00**

STD  
0.60mm

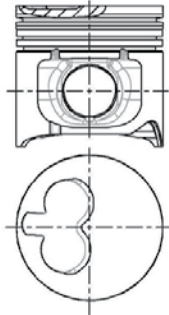



**08-783300-00**  
**08-783308-00**

STD  
0.60mm

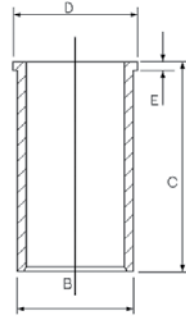

**14-021280-00 DH [11]**  
B 97.03 C 167.00 D 100.00 E 5.00  
**14-028930-00 D**  
B 97.50 C 167.00 D 100.90 E 5.00  
**14-028931-00 D**  
B 97.58 C 167.00 D 100.90 E 5.00  
**14-028932-00 D**  
B 97.70 C 167.00 D 100.90 E 5.00



A 54.00  
B- 2.20  
D 89.00  
 32x75

HA RT

[11] Nitrided

[11] Nitridé

[11] Nitruato

[11] Niturado

									
BE/PL	4	56.520/56.535	60.333/60.345	24.700	1.870	0.020/0.072	BS	1870CP	<b>71-4130/4</b> STD 0.25 0.50 0.75
BE/PL	4	56.520/56.535	60.333/60.345	24.700	1.870	0.020/0.070	BS	66575CP	<b>71-4185/4</b> STD 0.25 0.50 0.75

1870CP

66575CP

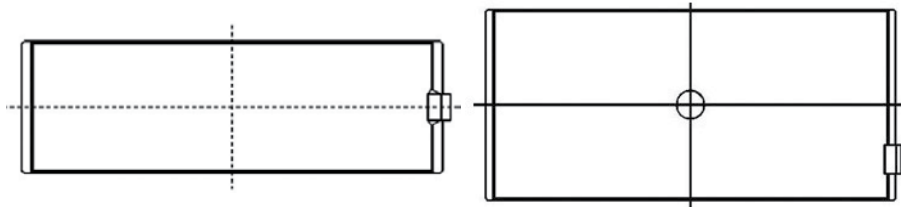

MB/HL 1-4	4	76.187/76.200	80.586/80.607	24.990	2.172	0.042/0.100	BS	66571CP	<b>H1049/5</b> STD 0.25 0.50 0.75
MB/HL 5	1	76.187/76.200	80.586/80.607	31.950	2.172	0.042/0.100	BS	66572CPH	
MB/HL 1-4	4	76.187/76.200	80.586/80.607	24.990	2.172	0.038/0.097	BS	66573CP	<b>H1094/5</b> STD 0.25
MB/HL 5	1	76.187/76.200	80.586/80.607	31.950	2.172	0.038/0.097	BS	66574CPH	

66571CP

66572CPH

66573CP

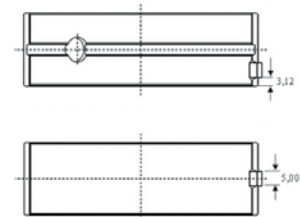
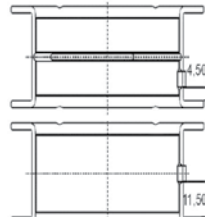
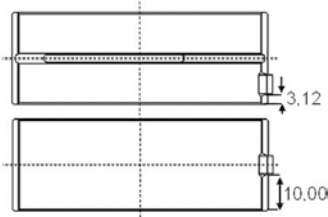



...Continued

**1306**  **93.00** **Diesel**

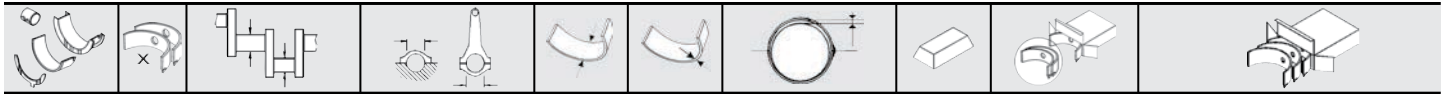

66574CPH

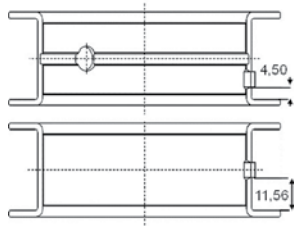

SE/PB	1	31.990/31.996	34.895/34.920	30.700		BS	66579YA	55-4186 SEMI
-------	---	---------------	---------------	--------	--	----	---------	-----------------

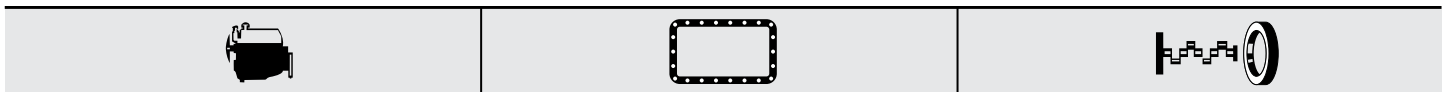

JJ519

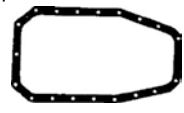

JJ519

**1307**  **93.00** **Diesel** 

8144.97	4 Cyl.		2499cc	85kW (115)PS	Turbo Intercooled	TD1061	668
8144.97 S	4 Cyl.	21:1	2500cc	77kW (105)PS	Turbo Intercooled	TD1059	680
8144.97.2400	4 Cyl.	21:1	2499cc	83-87kW (113-118)PS	Turbo Intercooled	TD22316	670

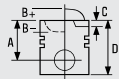
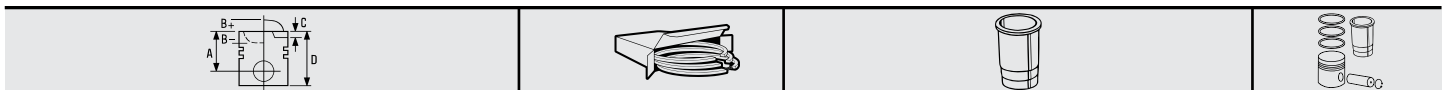

**08-245200-00** STD  
**08-245208-00** 0.60mm

3.00  
2.00  
3.00

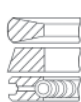

CR P  
P  
CR P

**14-021371-00 D**  
B 96.01 C 171.00 D 98.92 E 5.00  
**14-021372-00 D**  
B 96.05 C 171.00 D 98.92 E 5.00  
**14-021373-00 D**  
B 96.17 C 171.00 D 98.92 E 5.00  
**14-021480-00 DH [11]**  
B 97.04 C 171.00 D 100.00 E 5.00

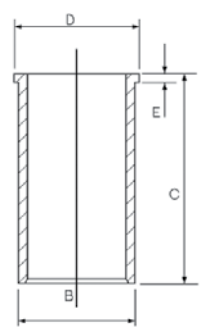

[11] Nitrided

[11] Nitridé









[11] Nitrurato

[11] Nitrurado

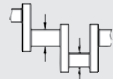
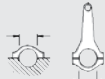
**1307**

 **93.00**

**Diesel**

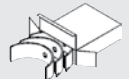
									
BE/PL	4	56.520/56.535	60.333/60.345	24.700	1.870	0.020/0.072	BS	1870CP	<b>71-4130/4</b> STD 0.25 0.50 0.75
BE/PL	4	56.520/56.535	60.333/60.345	24.700	1.870	0.020/0.070	BS	66575CP	<b>71-4185/4</b> STD 0.25 0.50 0.75

**1870CP**

**66575CP**

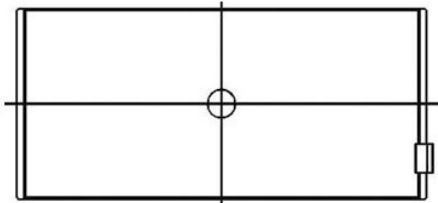
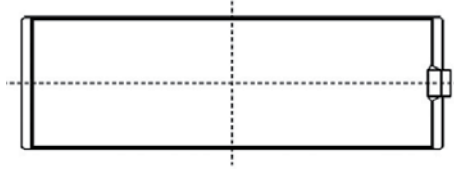

MB/HL 1-4	4	76.187/76.200	80.586/80.607	24.990	2.172	0.042/0.100	BS	66571CP	<b>H1049/5</b> STD 0.25 0.50 0.75
MB/HL 5	1	76.187/76.200	80.586/80.607	31.950	2.172	0.042/0.100	BS	66572CPH	
MB/HL 1-4	4	76.187/76.200	80.586/80.607	24.990	2.172	0.038/0.097	BS	66573CP	<b>H1094/5</b> STD 0.25
MB/HL 5	1	76.187/76.200	80.586/80.607	31.950	2.172	0.038/0.097	BS	66574CPH	

**66571CP**

**66572CPH**

**66573CP**

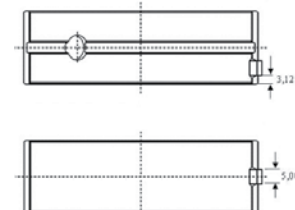
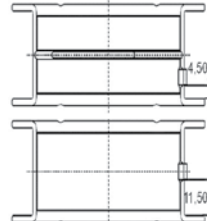
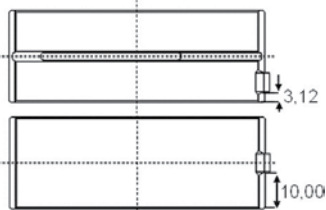

**66574CPH**

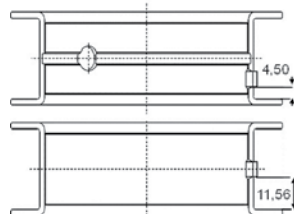

SE/PB	1	31.990/31.996	34.895/34.920	30.700			BS	66579YA	<b>55-4186</b> SEMI
-------	---	---------------	---------------	--------	--	--	----	---------	------------------------



**NF853**  100.00x118.00x10.00mm, FPM

## 1308

93.00

Diesel



8144.97

4 Cyl.

22:1

2499cc

85kW (115)PS

Turbocharged

TD4601

667

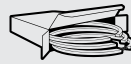
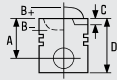

**08-245200-00** STD  
**08-245208-00** 0.60mm

3.00 CR P  
 2.00 P  
 3.00 CR P

**14-021371-00 D**  
**B 96.01 C 171.00 D 98.92 E 5.00**  
**14-021372-00 D**  
**B 96.05 C 171.00 D 98.92 E 5.00**  
**14-021373-00 D**  
**B 96.17 C 171.00 D 98.92 E 5.00**  
**14-021480-00 DH [11]**  
**B 97.04 C 171.00 D 100.00 E 5.00**

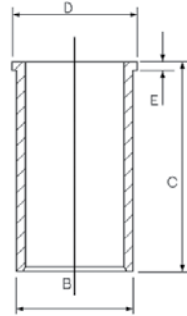

[11] Nitrided

[11] Nitridé

[11] Nitrurato

[11] Nitrurado

BE/PL	4	56.520/56.535	60.333/60.345	24.700	1.870	0.020/0.072	BS	1870CP	<b>71-4130/4</b> STD 0.25 0.50 0.75
BE/PL	4	56.520/56.535	60.333/60.345	24.700	1.870	0.020/0.070	BS	66575CP	<b>71-4185/4</b> STD 0.25 0.50 0.75

1870CP



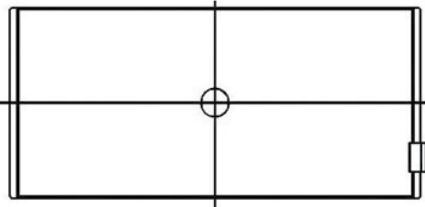
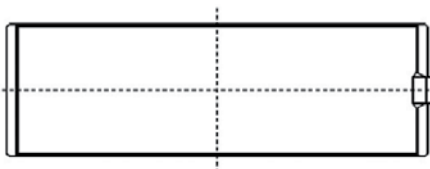







66575CP

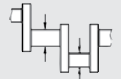

**1308**

 **93.00**

**Diesel**

									
MB/HL 1-4	4	76.187/76.200	80.586/80.607	24.990	2.172	0.042/0.100	BS	66571CP	<b>H1049/5</b> STD 0.25 0.50 0.75
MB/HL 5	1	76.187/76.200	80.586/80.607	31.950	2.172	0.042/0.100	BS	66572CPH	
MB/HL 1-4	4	76.187/76.200	80.586/80.607	24.990	2.172	0.038/0.097	BS	66573CP	<b>H1094/5</b> STD 0.25
MB/HL 5	1	76.187/76.200	80.586/80.607	31.950	2.172	0.038/0.097	BS	66574CPH	

**66571CP**

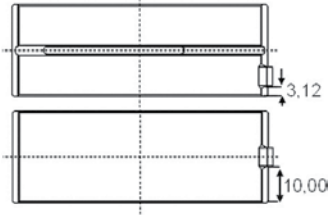

**66572CPH**

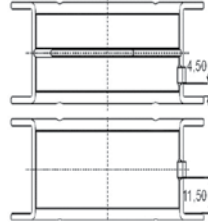

**66573CP**

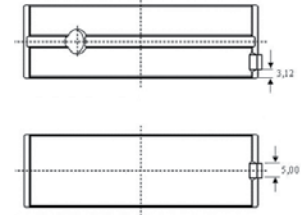

**66574CPH**

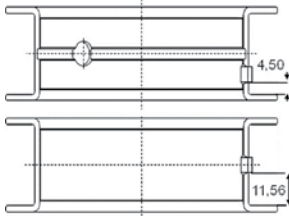

SE/PB	1	31.990/31.996	34.895/34.920	30.700		BS	66579YA	<b>55-4186</b> SEMI
-------	---	---------------	---------------	--------	--	----	---------	------------------------



JJ317

NF853  100.00x118.00x10.00mm, FPM



JJ317

## 1309

### 93.00

### Diesel



8144.97.2200

4 Cyl.

22:1

2499cc

85-87kW (116-118)PS

Turbo Intercooled

TD19036

669

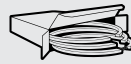
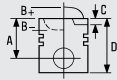

**08-245200-00** STD  
**08-245208-00** 0.60mm

3.00 CR P  
 2.00 P  
 3.00 CR P

**14-021371-00 D**  
**B 96.01 C 171.00 D 98.92 E 5.00**  
**14-021372-00 D**  
**B 96.05 C 171.00 D 98.92 E 5.00**  
**14-021373-00 D**  
**B 96.17 C 171.00 D 98.92 E 5.00**  
**14-021480-00 DH [11]**  
**B 97.04 C 171.00 D 100.00 E 5.00**

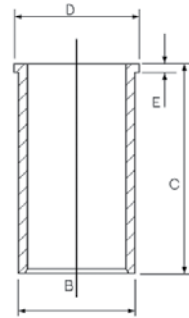

[11] Nitrided

[11] Nitridé

[11] Nitruato

[11] Nitruado

BE/PL	4	56.520/56.535	60.333/60.345	24.700	1.870	0.020/0.072	BS	1870CP	<b>71-4130/4</b> STD 0.25 0.50 0.75
BE/PL	4	56.520/56.535	60.333/60.345	24.700	1.870	0.020/0.070	BS	66575CP	<b>71-4185/4</b> STD 0.25 0.50 0.75

1870CP

66575CP

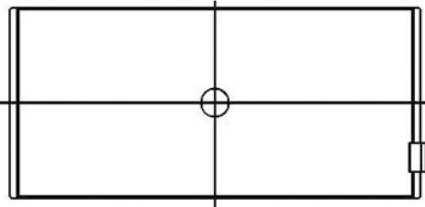
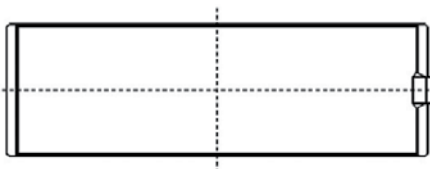

**1309**

**93.00**

**Diesel**

MB/HL 1-4	4	76.187/76.200	80.586/80.607	24.990	2.172	0.042/0.100	BS	66571CP	<b>H1049/5</b> STD 0.25 0.50 0.75
MB/HL 5	1	76.187/76.200	80.586/80.607	31.950	2.172	0.042/0.100	BS	66572CPH	
MB/HL 1-4	4	76.187/76.200	80.586/80.607	24.990	2.172	0.038/0.097	BS	66573CP	<b>H1094/5</b> STD 0.25
MB/HL 5	1	76.187/76.200	80.586/80.607	31.950	2.172	0.038/0.097	BS	66574CPH	

**66571CP**

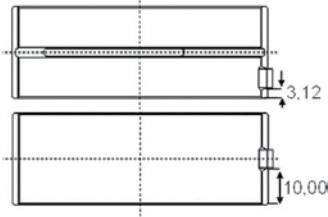

**66572CPH**

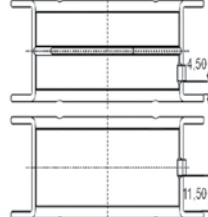

**66573CP**

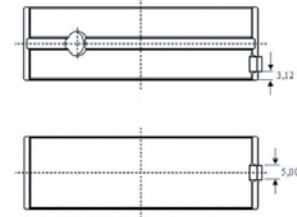

**66574CPH**

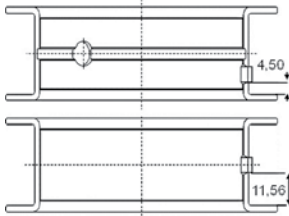

SE/PB	1	31.990/31.996	34.895/34.920	30.700			BS	66579YA	<b>55-4186</b> SEMI
-------	---	---------------	---------------	--------	--	--	----	---------	------------------------



**NP067** 50.00x70.00x10.00mm, FPM

**1310**

**93.00**

**Diesel**



**8140.07.2585 Euro I**    4 Cyl.    18.5:1    2500cc    **55kW (75)PS**    **TD20437**    **671**

<p><b>87-425000-00</b>    STD</p> <p><b>87-425008-00</b>    0.60mm</p> <p>A 58.75</p> <p>B- 16.90</p> <p>BØ 40.00</p> <p>D 96.75</p> <p> 32x75</p> <p>RT</p>	<p><b>08-425000-00</b>    STD</p> <p><b>08-425008-00</b>    0.60mm</p> <p>3.00  CR P</p> <p>2.00  P</p> <p>3.00  CR P</p>	<p><b>14-021371-00 D</b></p> <p>B 96.01    C 171.00    D 98.92    E 5.00</p> <p><b>14-021372-00 D</b></p> <p>B 96.05    C 171.00    D 98.92    E 5.00</p> <p><b>14-021373-00 D</b></p> <p>B 96.17    C 171.00    D 98.92    E 5.00</p> <p><b>14-021480-00 DH [11]</b></p> <p>B 97.04    C 171.00    D 100.00    E 5.00</p>	

[11] Nitrided









[11] Nitridé

[11] Niturato

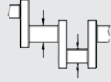
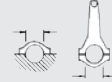
[11] Niturado

...Continued

**1310**  **93.00** **Diesel**

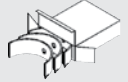
									
BE/PL	4	56.520/56.535	60.333/60.345	24.700	1.870	0.020/0.072	BS	1870CP	<b>71-4130/4</b> STD 0.25 0.50 0.75
MB/HL 1-4	4	76.187/76.200	80.586/80.607	24.990	2.172	0.042/0.100	BS	66571CP	<b>H1049/5</b> STD 0.25 0.50 0.75
MB/HL 5	1	76.187/76.200	80.586/80.607	31.950	2.172	0.042/0.100	BS	66572CPH	
→12/92, Mot.→1846776									
MB/HL 1-4	4	76.187/76.200	80.586/80.607	24.990	2.172	0.038/0.097	BS	66573CP	<b>H1094/5</b> STD 0.25
MB/HL 5	1	76.187/76.200	80.586/80.607	31.950	2.172	0.038/0.097	BS	66574CPH	
Mot.1846777→									

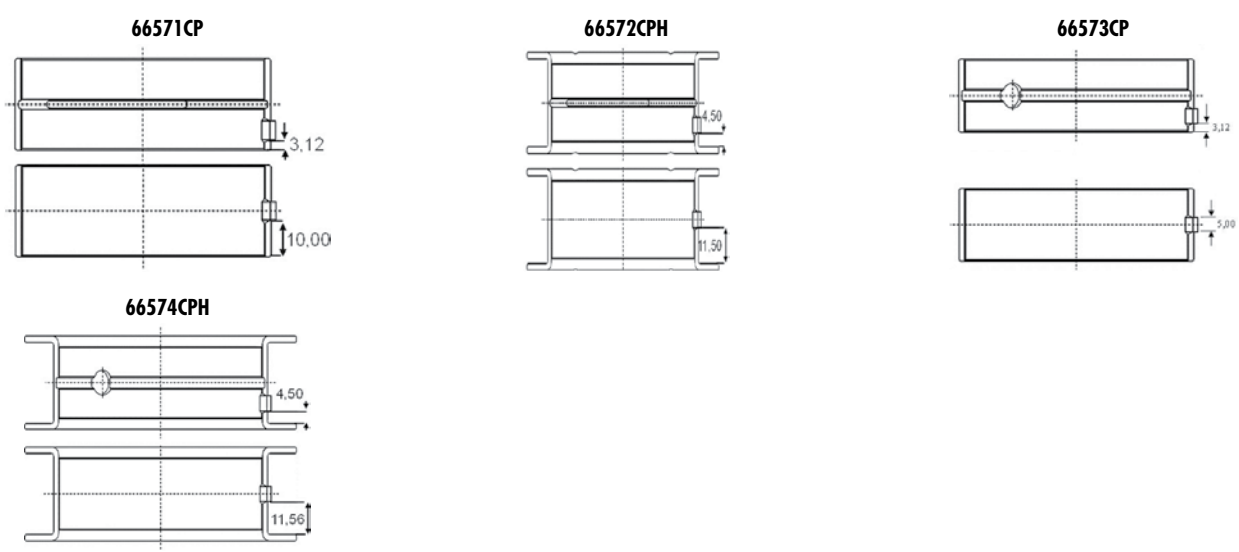

SE/PB	1	31.990/31.996	34.895/34.920	30.700			BS	66579YA	<b>55-4186</b> SEMI
-------	---	---------------	---------------	--------	--	--	----	---------	------------------------

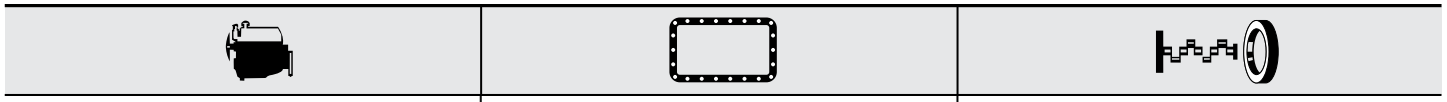

JJ519



JJ519

NP067  50.00x70.00x10.00mm, FPM











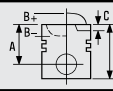
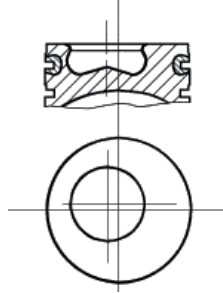

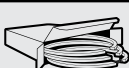
## 1311

 93.00

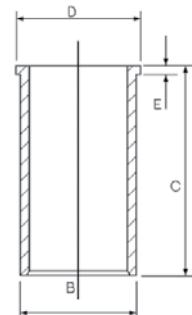

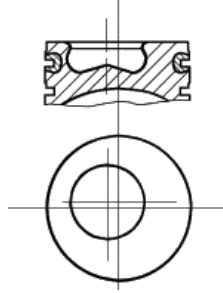





**Diesel**

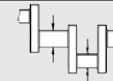

8140.27      4 Cyl.      18.5:1      2500cc      70kW (95)PS      Turbocharged      TD1047      672

 <p><b>87-245200-40</b> <b>87-245208-40</b></p> <p>STD 0.60mm</p>  <p>A 58.75 B- 17.90 BØ 38.00 D 96.75  32x75</p> <p>RT</p>	 <p><b>08-245200-00</b> STD <b>08-245208-00</b> 0.60mm</p> <p>3.00  CR P 2.00  P 3.00  CR P</p>	 <p><b>14-021371-00 D</b> B 96.01 C 171.00 D 98.92 E 5.00 <b>14-021372-00 D</b> B 96.05 C 171.00 D 98.92 E 5.00 <b>14-021373-00 D</b> B 96.17 C 171.00 D 98.92 E 5.00 <b>14-021480-00 DH [11]</b> B 97.04 C 171.00 D 100.00 E 5.00</p> 	
<p><b>87-245200-50</b> <b>87-245208-50</b></p> <p>STD 0.60mm</p>  <p>A 58.75 B- 17.90 BØ 38.00 D 96.75  32x78</p> <p>AK NB RT</p>	<p><b>08-245200-00</b> STD <b>08-245208-00</b> 0.60mm</p> <p>3.00  CR P 2.00  P 3.00  CR P</p>		

[11] Nitrided      [11] Nitride      [11] Nitrurato      [11] Nitrurado

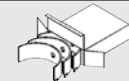
									
BE/PL	4	56.520/56.535	60.333/60.345	24.700	1.870	0.020/0.072	BS	1870CP	<b>71-4130/4</b> STD 0.25 0.50 0.75
BE/PL	4	56.520/56.535	60.333/60.345	24.700	1.870	0.020/0.070	BS	66575CP	<b>71-4185/4</b> STD 0.25 0.50 0.75

1870CP

66575CP

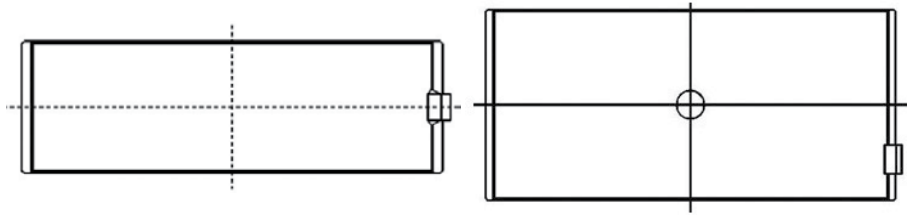

MB/HL 1-4	4	76.187/76.200	80.586/80.607	24.990	2.172	0.042/0.100	BS	66571CP	<b>H1049/5</b> STD 0.25 0.50 0.75
MB/HL 5	1	76.187/76.200	80.586/80.607	31.950	2.172	0.042/0.100	BS	66572CPH	
MB/HL 1-4	4	76.187/76.200	80.586/80.607	24.990	2.172	0.038/0.097	BS	66573CP	<b>H1094/5</b> STD 0.25
MB/HL 5	1	76.187/76.200	80.586/80.607	31.950	2.172	0.038/0.097	BS	66574CPH	



...Continued

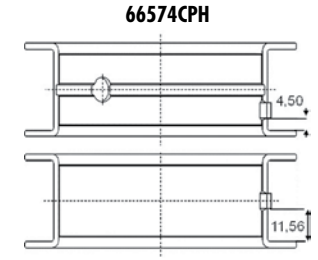
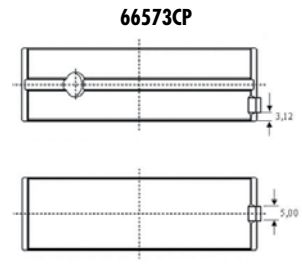
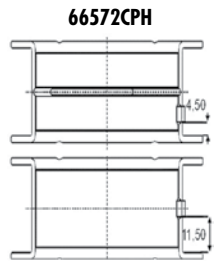
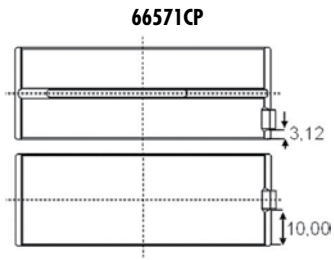
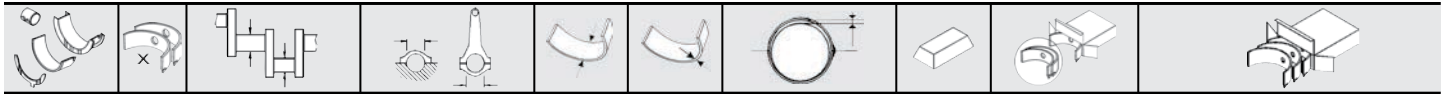

**1311**  **93.00** Diesel

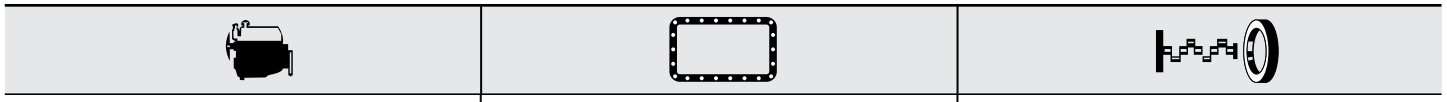

SE/PB	1	31.990/31.996	34.895/34.920	30.700		BS	66579YA	55-4186 SEMI
-------	---	---------------	---------------	--------	--	----	---------	-----------------



JJ519

**NB946**  70.00x90.00x10.00mm, FPM  
**NF853**  100.00x118.00x10.00mm, FPM

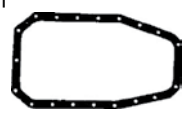

JJ519

## 1312

 93.00

**Diesel**



8140.27.2100

4 Cyl.

18.5:1











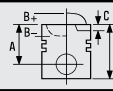
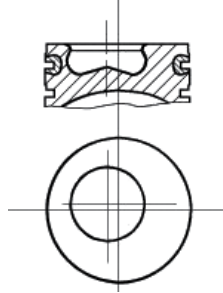

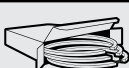
2500cc

70kW (95)PS

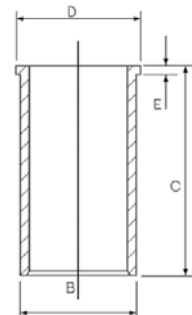
Turbocharged

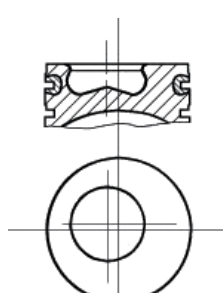
TD6800

673









 <p><b>87-245200-40</b> <b>87-245208-40</b></p> <p>STD 0.60mm</p>  <p>A 58.75 B- 17.90 BØ 38.00 D 96.75  32x75</p> <p>RT</p>	 <p><b>08-245200-00</b> STD <b>08-245208-00</b> 0.60mm</p> <p>3.00  CR P 2.00  P 3.00  CR P</p>	 <p><b>14-021371-00 D</b> B 96.01 C 171.00 D 98.92 E 5.00 <b>14-021372-00 D</b> B 96.05 C 171.00 D 98.92 E 5.00 <b>14-021373-00 D</b> B 96.17 C 171.00 D 98.92 E 5.00 <b>14-021480-00 DH [11]</b> B 97.04 C 171.00 D 100.00 E 5.00</p> 	
<p><b>87-245200-50</b> <b>87-245208-50</b></p> <p>STD 0.60mm</p>  <p>A 58.75 B- 17.90 BØ 38.00 D 96.75  32x78</p> <p>AK NB RT</p>	<p><b>08-245200-00</b> STD <b>08-245208-00</b> 0.60mm</p> <p>3.00  CR P 2.00  P 3.00  CR P</p>		

[11] Nitrided

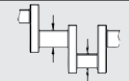
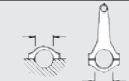
[11] Nitride

[11] Niturato

[11] Niturado

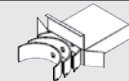
									
BE/PL	4	56.520/56.535	60.333/60.345	24.700	1.870	0.020/0.072	BS	1870CP	<b>71-4130/4</b> STD 0.25 0.50 0.75
BE/PL	4	56.520/56.535	60.333/60.345	24.700	1.870	0.020/0.070	BS	66575CP	<b>71-4185/4</b> STD 0.25 0.50 0.75

1870CP

66575CP

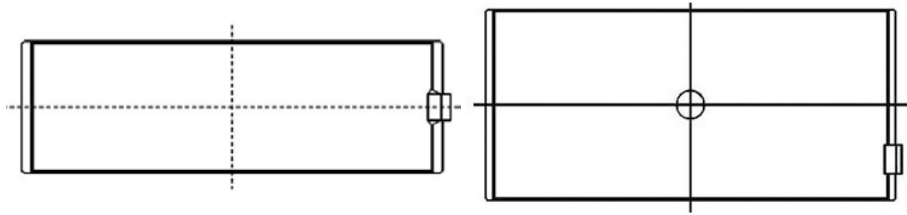

MB/HL 1-4	4	76.187/76.200	80.586/80.607	24.990	2.172	0.042/0.100	BS	66571CP	<b>H1049/5</b> STD 0.25 0.50 0.75
MB/HL 5	1	76.187/76.200	80.586/80.607	31.950	2.172	0.042/0.100	BS	66572CPH	
MB/HL 1-4	4	76.187/76.200	80.586/80.607	24.990	2.172	0.038/0.097	BS	66573CP	<b>H1094/5</b> STD 0.25
MB/HL 5	1	76.187/76.200	80.586/80.607	31.950	2.172	0.038/0.097	BS	66574CPH	

...Continued

**1312**  **93.00 Diesel**

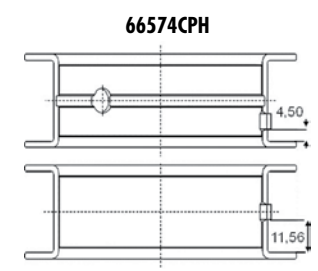
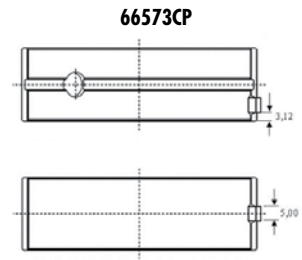
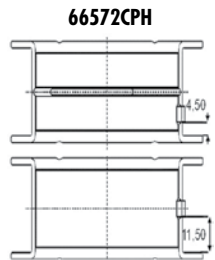
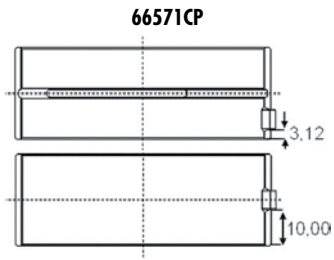
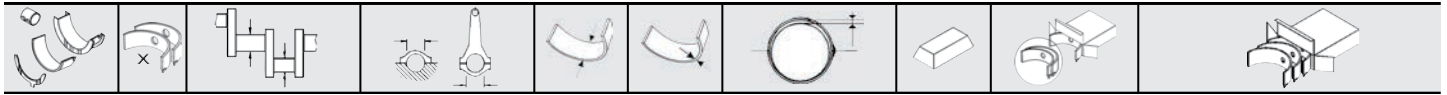

SE/PB	1	31.990/31.996	34.895/34.920	30.700		BS	66579YA	55-4186 SEMI
-------	---	---------------	---------------	--------	--	----	---------	--------------

**1313**  **93.00 Diesel** 

<b>8140.47</b>	4 Cyl.	18.5:1	2500cc	<b>80-85kW (109-116)PS</b>	<b>Turbocharged</b>	<b>TD1048</b>	<b>674</b>
<b>8140.47R</b>	4 Cyl.	18.5:1	2500cc	<b>80kW (110)PS</b>	<b>Turbocharged</b>	<b>TD1049</b>	<b>675</b>









<p><b>87-520200-00</b> STD</p> <p>A 58.75 B- 18.40 BØ 38.00 D 96.75  32x78</p> <p>AK KK NB RT</p>	<p><b>08-520200-00</b> STD</p> <p>3.00 CR 2.00 P 3.00 CR P</p>	<p><b>14-021371-00 D</b> B 96.01 C 171.00 D 98.92 E 5.00</p> <p><b>14-021372-00 D</b> B 96.05 C 171.00 D 98.92 E 5.00</p> <p><b>14-021373-00 D</b> B 96.17 C 171.00 D 98.92 E 5.00</p> <p><b>14-021480-00 DH [11]</b> B 97.04 C 171.00 D 100.00 E 5.00</p>	

[11] Nitrided      [11] Nitridé      [11] Nitrurato      [11] Nitrurado

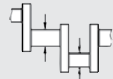
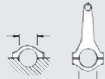
**1313**

 **93.00**

**Diesel**

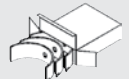
									
BE/PL	4	56.520/56.535	60.333/60.345	24.700	1.870	0.020/0.072	BS	1870CP	<b>71-4130/4</b> STD 0.25 0.50 0.75
BE/PL	4	56.520/56.535	60.333/60.345	24.700	1.870	0.020/0.070	BS	66575CP	<b>71-4185/4</b> STD 0.25 0.50 0.75

**1870CP**

**66575CP**

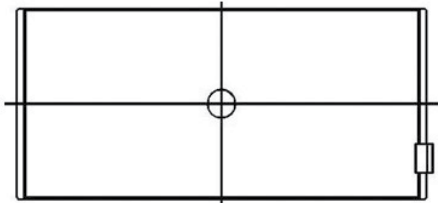
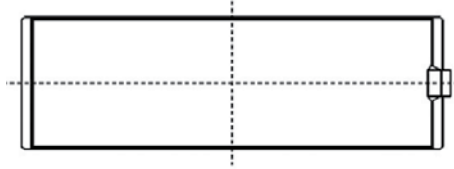

MB/HL 1-4	4	76.187/76.200	80.586/80.607	24.990	2.172	0.042/0.100	BS	66571CP	<b>H1049/5</b> STD 0.25 0.50 0.75
MB/HL 5	1	76.187/76.200	80.586/80.607	31.950	2.172	0.042/0.100	BS	66572CPH	
MB/HL 1-4	4	76.187/76.200	80.586/80.607	24.990	2.172	0.038/0.097	BS	66573CP	<b>H1094/5</b> STD 0.25
MB/HL 5	1	76.187/76.200	80.586/80.607	31.950	2.172	0.038/0.097	BS	66574CPH	

**66571CP**

**66572CPH**

**66573CP**

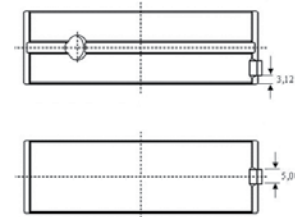
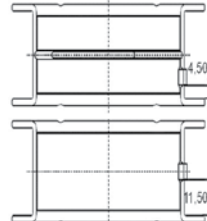
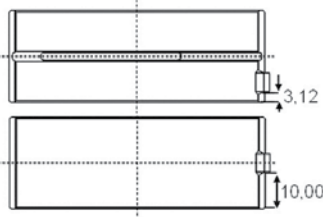

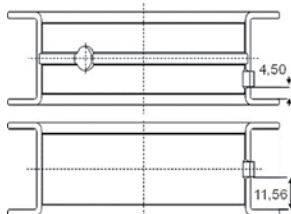

**66574CPH**



SE/PB	1	31.990/31.996	34.895/34.920	30.700			BS	66579YA	<b>55-4186</b> SEMI
-------	---	---------------	---------------	--------	--	--	----	---------	------------------------



**JH5178**  
Soft Material Gasket

**NB946**  70.00x90.00x10.00mm, FPM  
**NF853**  100.00x118.00x10.00mm, FPM



**JH5178**

<b>1314</b>	<b>93.00</b>	<b>Diesel</b>	
<b>8140.67</b>	4 Cyl.	22:1	2500cc
<b>55-62kW (75-84)PS</b>			<b>TD1052 676</b>

<b>87-425000-10</b> <b>87-425008-10</b>  <b>A</b> 54.00 <b>B-</b> 2.20 <b>D</b> 89.00 32x68  <b>HA RT</b>	<b>STD</b> <b>0.60mm</b>  	<b>08-425000-00</b> <b>STD</b> <b>08-425008-00</b> <b>0.60mm</b>  <b>3.00</b> <b>CR P</b> <b>2.00</b> <b>P</b> <b>3.00</b> <b>CR P</b>	<b>14-021371-00 D</b> <b>B 96.01 C 171.00 D 98.92 E 5.00</b> <b>14-021372-00 D</b> <b>B 96.05 C 171.00 D 98.92 E 5.00</b> <b>14-021373-00 D</b> <b>B 96.17 C 171.00 D 98.92 E 5.00</b> <b>14-021480-00 DH [11]</b> <b>B 97.04 C 171.00 D 100.00 E 5.00</b>  

[11] Nitrided                      [11] Nitridé                      [11] Nitrurato                      [11] Nitrurado

BE/PL	4	56.520/56.535	60.333/60.345	24.700	1.870	0.020/0.072	BS	1870CP	<b>71-4130/4</b> STD 0.25 0.50 0.75
BE/PL	4	56.520/56.535	60.333/60.345	24.700	1.870	0.020/0.070	BS	66575CP	<b>71-4185/4</b> STD 0.25 0.50 0.75

**1870CP**



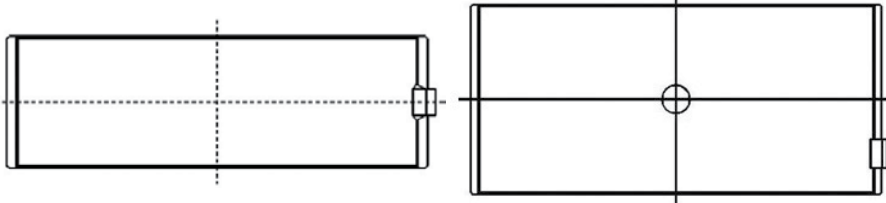





**66575CP**

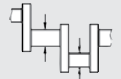

**1314**

 **93.00**

**Diesel**

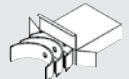
									
MB/HL 1-4	4	76.187/76.200	80.586/80.607	24.990	2.172	0.042/0.100	BS	66571CP	<b>H1049/5</b> STD 0.25 0.50 0.75
MB/HL 5	1	76.187/76.200	80.586/80.607	31.950	2.172	0.042/0.100	BS	66572CPH	
MB/HL 1-4	4	76.187/76.200	80.586/80.607	24.990	2.172	0.038/0.097	BS	66573CP	<b>H1094/5</b> STD 0.25
MB/HL 5	1	76.187/76.200	80.586/80.607	31.950	2.172	0.038/0.097	BS	66574CPH	

**66571CP**

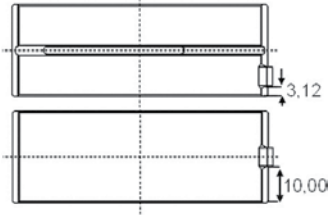

**66572CPH**

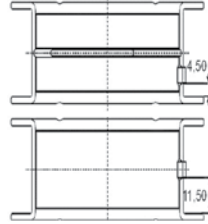

**66573CP**

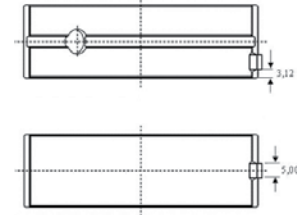

**66574CPH**

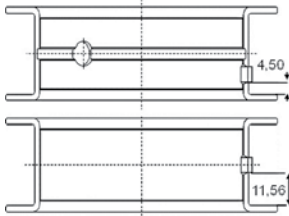



SE/PB	1	31.990/31.996	34.895/34.920	30.700		BS	66579YA	<b>55-4186</b> SEMI
-------	---	---------------	---------------	--------	--	----	---------	------------------------











**JH5178**  
Soft Material Gasket



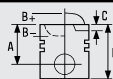
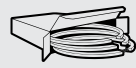

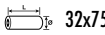
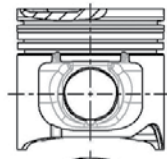
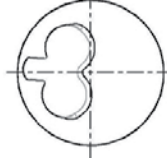
**JH5178**



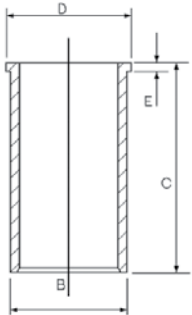



**NB946**  70.00x90.00x10.00mm, FPM  
**NF853**  100.00x118.00x10.00mm, FPM

**1315**  **93.00 Diesel**   
**8140.67 (290B7W), 8144.67** 4 Cyl. 22:1 2500cc **FM9170 613**

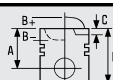
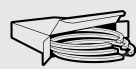

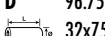
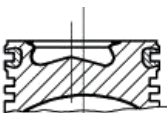
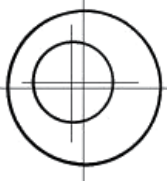



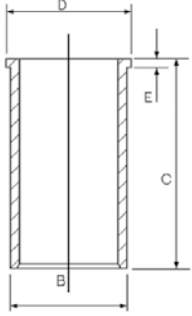

			
<p><b>87-783300-00</b> STD  <b>87-783308-00</b> 0.60mm</p> <p>A 54.00          B- 2.20          D 89.00   32x75</p> <p>HA RT</p>	 	<p><b>08-783300-00</b> STD  <b>08-783308-00</b> 0.60mm</p> <p>3.00  CR P          2.00  P          3.00  CR P</p>	<p><b>14-021280-00 DH [11]</b>  <b>B 97.03 C 167.00 D 100.00 E 5.00</b>  <b>14-022560-00 D</b>  <b>B 96.00 C 167.30 D 98.90 E 5.00</b>  <b>14-028930-00 D</b>  <b>B 97.50 C 167.00 D 100.90 E 5.00</b></p> 

[11] Nitrided [11] Nitridé [11] Nitrurato [11] Nitrurado

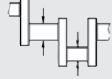
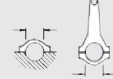
**1316**  **93.00 Diesel**   
**8140.67.2585 Euro 2** 4 Cyl. 18.5:1 2500cc **55-63kW (75-86)PS** **Turbo Intercooled** **TD20427 677**

			
<p><b>87-425000-00</b> STD  <b>87-425008-00</b> 0.60mm</p> <p>A 58.75          B- 16.90          BØ 40.00          D 96.75   32x75</p> <p>RT</p>	 	<p><b>08-425000-00</b> STD  <b>08-425008-00</b> 0.60mm</p> <p>3.00  CR P          2.00  P          3.00  CR P</p>	<p><b>14-021371-00 D</b>  <b>B 96.01 C 171.00 D 98.92 E 5.00</b>  <b>14-021372-00 D</b>  <b>B 96.05 C 171.00 D 98.92 E 5.00</b>  <b>14-021373-00 D</b>  <b>B 96.17 C 171.00 D 98.92 E 5.00</b>  <b>14-021480-00 DH [11]</b>  <b>B 97.04 C 171.00 D 100.00 E 5.00</b></p> 

[11] Nitrided [11] Nitridé [11] Nitrurato [11] Nitrurado

									
BE/PL	4	56.520/56.535	60.333/60.345	24.700	1.870	0.020/0.072	BS	1870CP	<b>71-4130/4</b> STD 0.25 0.50 0.75
MB/HL 5	1	86.182/86.208	90.588/90.614	30.950	2.164	0.052/0.129	BS	4691CPH	<b>H1104/5</b> STD 0.25 0.50
MB/HL 1-4	4	80.182/80.208	84.588/84.614	23.800	2.164	0.052/0.129	BS	4692CP	
<b>09/95 →</b>									
SE/PB	1	31.990/31.996	34.895/34.920	30.700			BS	66579YA	<b>55-4186</b> SEMI
<b>Mot.344183 →</b>									

# FIAT GROUP

...Continued

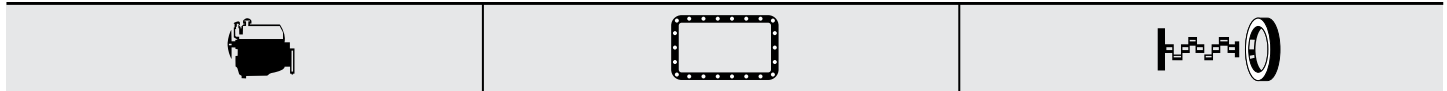

## 1316 93.00 Diesel



**JJ100**  
(Cork)



JJ100

**NA5055**  70.00x90.00x10.00mm, FPM  
**NF883**  114.00x177.00x13.00mm, FPM  
**NF885**  70.00x179.00x16.00mm, FPM

## 1317 93.00 Diesel

8140 SC 27.02      4 Cyl.      18.5:1      2500cc      62kW (84)PS      TD16182      678

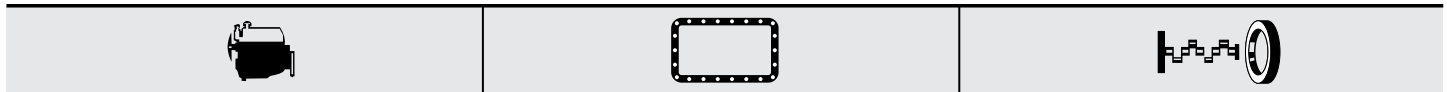

**JJ100**  
(Cork)



JJ100

**NP067**  50.00x70.00x10.00mm, FPM

## 1318 93.00 Diesel

8144.67      4 Cyl.      22:1      2500cc      55kW (75)PS      TD1056      679

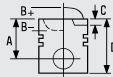
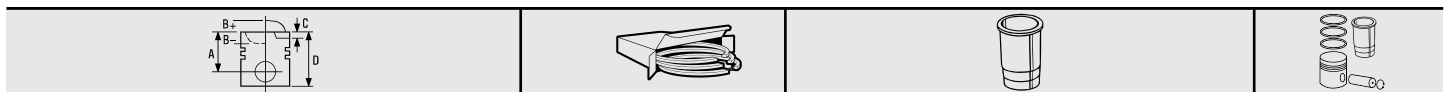

**87-783300-00**  
**87-783308-00**

STD  
0.60mm

**A** 54.00  
**B-** 2.20  
**D** 89.00  
 32x75

HA RT

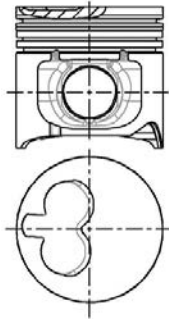

**08-783300-00**  
**08-783308-00**

STD  
0.60mm

3.00  CR P  
2.00  P  
3.00  CR P

[11] Niturado

[11] Niturado

**14-021280-00 DH** [11]  
**B** 97.03    **C** 167.00    **D** 100.00    **E** 5.00  
**14-028930-00 D**  
**B** 97.50    **C** 167.00    **D** 100.90    **E** 5.00  
**14-028931-00 D**  
**B** 97.58    **C** 167.00    **D** 100.90    **E** 5.00  
**14-028932-00 D**  
**B** 97.70    **C** 167.00    **D** 100.90    **E** 5.00

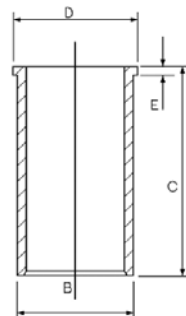









[11] Nitrided

[11] Nitridé

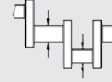
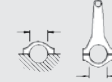

...Continued

**1318**  **93.00 Diesel**

									
BE/PL	4	56.520/56.535	60.333/60.345	24.700	1.870	0.020/0.072	BS	1870CP	<b>71-4130/4</b> STD 0.25 0.50 0.75
BE/PL	4	56.520/56.535	60.333/60.345	24.700	1.870	0.020/0.070	BS	66575CP	<b>71-4185/4</b> STD 0.25 0.50 0.75

**1870CP**

**66575CP**

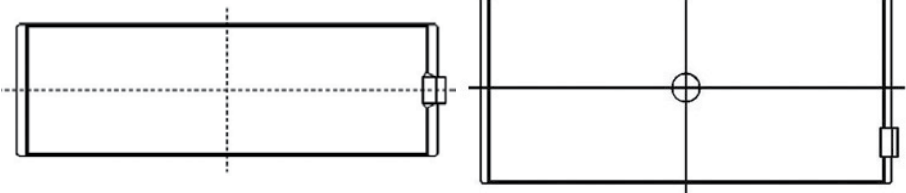

MB/HL 1-4	4	76.187/76.200	80.586/80.607	24.990	2.172	0.042/0.100	BS	66571CP	<b>H1049/5</b> STD 0.25 0.50 0.75
MB/HL 5	1	76.187/76.200	80.586/80.607	31.950	2.172	0.042/0.100	BS	66572CPH	
MB/HL 1-4	4	76.187/76.200	80.586/80.607	24.990	2.172	0.038/0.097	BS	66573CP	<b>H1094/5</b> STD 0.25
MB/HL 5	1	76.187/76.200	80.586/80.607	31.950	2.172	0.038/0.097	BS	66574CPH	

**66571CP**

**66572CPH**

**66573CP**

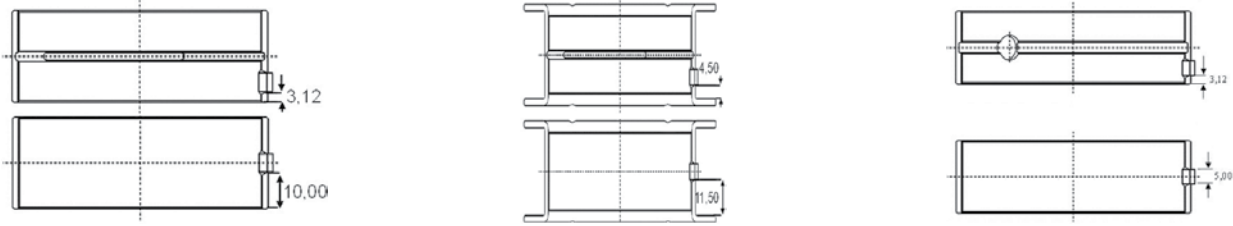

**66574CPH**

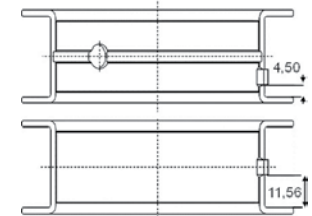



SE/PB	1	31.990/31.996	34.895/34.920	30.700			BS	66579YA	<b>55-4186</b> SEMI
-------	---	---------------	---------------	--------	--	--	----	---------	------------------------



**JJ100**  
(Cork)  
**JJ519**

**JJ100**      **JJ519**

**NB946**  70.00x90.00x10.00mm, FPM  
**NF853**  100.00x118.00x10.00mm, FPM

## 1319

 93.00

**Diesel**



<b>8144.97S</b>	4 Cyl.	21:1	2500cc	<b>77kW (105)PS</b>	<b>Turbocharged</b>	<b>TD1785</b>	<b>681</b>
<b>8144.97 Y</b>	4 Cyl.	22.5:1	2500cc	<b>85kW (115)PS</b>	<b>Turbocharged</b>	<b>TD1786</b>	<b>683</b>

	<p><b>08-245200-00</b> STD  <b>08-245208-00</b> 0.60mm</p> <p>3.00  CR P                  2.00  P                  3.00  CR P</p>	<p><b>14-021371-00 D</b>                  B 96.01 C 171.00 D 98.92 E 5.00  <b>14-021372-00 D</b>                  B 96.05 C 171.00 D 98.92 E 5.00  <b>14-021373-00 D</b>                  B 96.17 C 171.00 D 98.92 E 5.00  <b>14-021480-00 DH [11]</b>                  B 97.04 C 171.00 D 100.00 E 5.00</p>	

[11] Nitrided

[11] Nitridé

[11] Niturato

[11] Niturado

BE/PL	4	56.520/56.535	60.333/60.345	24.700	1.870	0.020/0.072	BS	1870CP	<b>71-4130/4</b> STD 0.25 0.50 0.75
BE/PL	4	56.520/56.535	60.333/60.345	24.700	1.870	0.020/0.070	BS	66575CP	<b>71-4185/4</b> STD 0.25 0.50 0.75





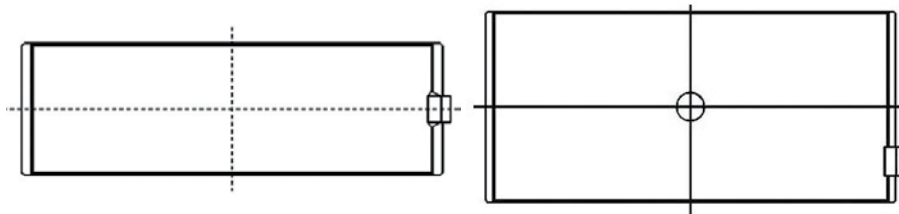



**1870CP**

**66575CP**

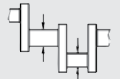
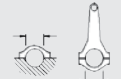

...Continued

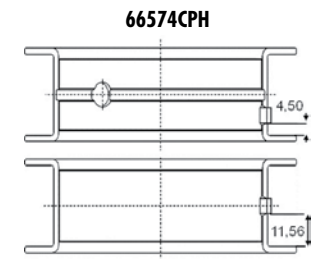
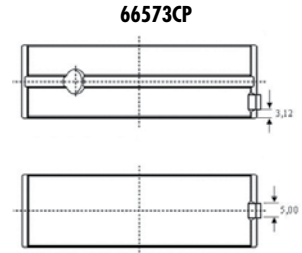
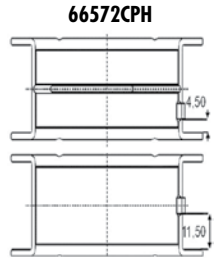
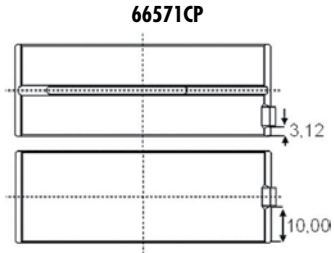

**1319**  **93.00** Diesel

									
MB/HL 1-4	4	76.187/76.200	80.586/80.607	24.990	2.172	0.042/0.100	BS	66571CP	<b>H1049/5</b> STD 0.25 0.50 0.75
MB/HL 5	1	76.187/76.200	80.586/80.607	31.950	2.172	0.042/0.100	BS	66572CPH	
MB/HL 1-4	4	76.187/76.200	80.586/80.607	24.990	2.172	0.038/0.097	BS	66573CP	<b>H1094/5</b> STD 0.25
MB/HL 5	1	76.187/76.200	80.586/80.607	31.950	2.172	0.038/0.097	BS	66574CPH	

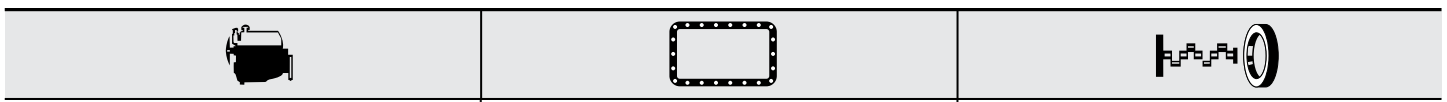

SE/PB	1	31.990/31.996	34.895/34.920	30.700			BS	66579YA	<b>55-4186</b> SEMI
-------	---	---------------	---------------	--------	--	--	----	---------	------------------------



**NP068**  55.00x70.00x8.00mm, FPM  
**NF853**  100.00x118.00x10.00mm, FPM

## 1320

 93.00

**Diesel**



8144.97 Y      4 Cyl.      22.5:1      2500cc      **85kW (115)PS**      **Turbo Intercooled**      **TD1060**      **682**

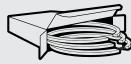
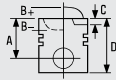







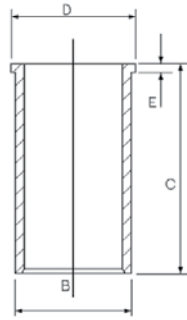

**08-245200-00** STD  
**08-245208-00** 0.60mm

3.00  CR P  
 2.00  P  
 3.00  CR P

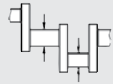
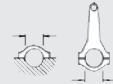
**14-021371-00 D**  
 B 96.01 C 171.00 D 98.92 E 5.00  
**14-021372-00 D**  
 B 96.05 C 171.00 D 98.92 E 5.00  
**14-021373-00 D**  
 B 96.17 C 171.00 D 98.92 E 5.00  
**14-021480-00 DH [11]**  
 B 97.04 C 171.00 D 100.00 E 5.00



[11] Nitrided      [11] Nitridé      [11] Nitruato      [11] Nitruado

									
BE/PL	4	56.520/56.535	60.333/60.345	24.700	1.870	0.020/0.072	BS	1870CP	<b>71-4130/4</b> STD 0.25 0.50 0.75
BE/PL	4	56.520/56.535	60.333/60.345	24.700	1.870	0.020/0.070	BS	66575CP	<b>71-4185/4</b> STD 0.25 0.50 0.75

**1870CP**

**66575CP**

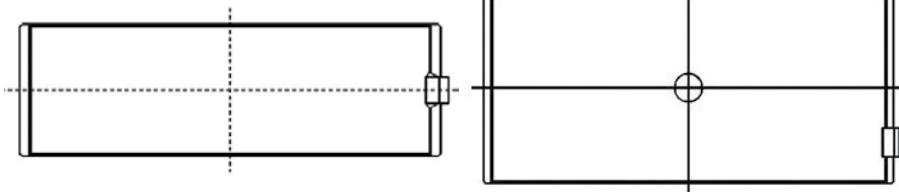

...Continued

**1320**  **93.00 Diesel**

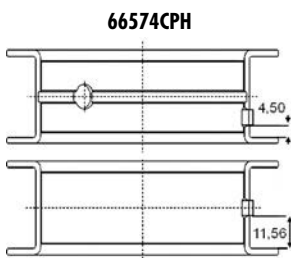
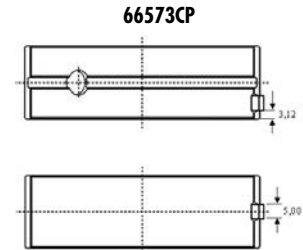
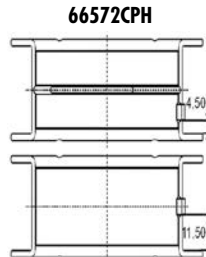
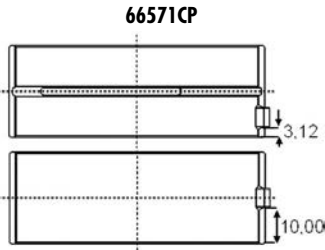

MB/HL 1-4	4	76.187/76.200	80.586/80.607	24.990	2.172	0.042/0.100	BS	66571CP	H1049/5 STD 0.25 0.50 0.75
MB/HL 5	1	76.187/76.200	80.586/80.607	31.950	2.172	0.042/0.100	BS	66572CPH	
MB/HL 1-4	4	76.187/76.200	80.586/80.607	24.990	2.172	0.038/0.097	BS	66573CP	H1094/5 STD 0.25
MB/HL 5	1	76.187/76.200	80.586/80.607	31.950	2.172	0.038/0.097	BS	66574CPH	







SE/PB	1	31.990/31.996	34.895/34.920	30.700			BS	66579YA	55-4186 SEMI
-------	---	---------------	---------------	--------	--	--	----	---------	-----------------

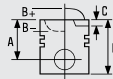
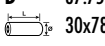
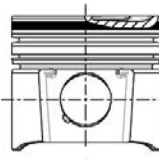
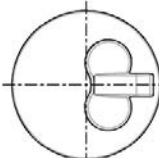
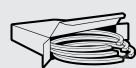

NP068 55.00x70.00x8.00mm, FPM

**1321**  **93.00 Diesel** 

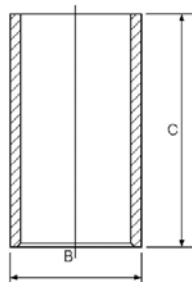
CRD93L (U25-661) 4 Cyl. 22.25:1 2500cc 54-55kW (73-75)PS TD22981 684

 <p>87-152700-00 STD 87-152707-00 0.50mm</p> <p>A 52.75 B- 7.30 D 87.75  30x78</p>  	 <p>08-152700-00 STD 08-152707-00 0.50mm</p> <p>2.50 MOL P 2.00 P 4.00 CR P</p> 	 <p>14-013481-00 D B 96.10 C 163.00</p> 	
---	--	---	---









# FIAT GROUP



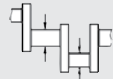
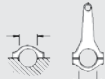

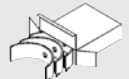

...Continued

## 1321

 93.00

Diesel

									
BE/PL	4	53.990/54.005	57.675/57.685	24.500	1.826	0.020/0.069	AL-LF	66440RAA	<b>01-4181/4</b> STD 0.25 0.50
MB/HL 1-5	5	67.035/67.050	71.695/71.705	28.700	2.317	0.020/0.061	AL-LF	66716RAA	<b>H1089/5</b> STD 0.25 0.50
TW/A	4	75.500/75.750	89.000/89.100		3.140		BS	66716BF	<b>A213/4</b> STD
SE/PB	1	30.008/30.014	33.000/33.033	31.900			BS	66444X	<b>55-4393</b> STD

		
	JJ100 (Cork) JJ519  JJ100                      JJ519	NB946  70.00x90.00x10.00mm, FPM NF853  100.00x118.00x10.00mm, FPM







## 1322



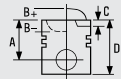





 93.00

Petrol

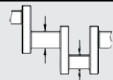
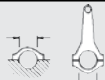





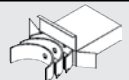



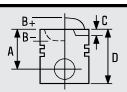
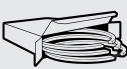



834 F.000                      6 Cyl.                      2959cc                      126kW (171)PS                      TD1841                      685



			
	08-527500-00    STD  1.50  CR P 1.50  P 3.50  P		

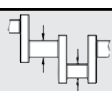
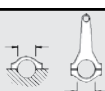



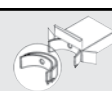
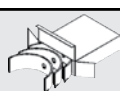

									
BE/PL	6	51.980/52.000	55.511/55.524	19.100	1.749	0.020/0.071	BS	4080CP	<b>71-4218/6</b> STD 0.25
MB/HL 1-4	4	59.951/59.971	63.657/63.676	22.350	1.841	0.020/0.068	BS	4081CP	<b>H1082/4</b> STD 0.25
SE/PB	1	21.994/22.000	25.120/25.146	23.720			BS	60014X	<b>55-4280</b> SEMI

1323	 93.00	Petrol			
838 B.000	6 Cyl.	10:1	2959cc	150kW (204)PS	TD4620 686
AR 16102	6 Cyl.	10.1:1	2959cc	162kW (220)PS	TD5495 692
AR 16105	6 Cyl.		2959cc	160kW (218)PS	TD15970 693
AR 34301	6 Cyl.	10:1	2959cc	166kW (226)PS	TD11603 694
AR 36101	6 Cyl.		2959cc	162kW (220)PS	TD15393 696

			
<b>08-138800-00</b> STD 1.20  NT P 1.50  P 3.50  P			

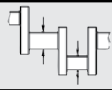
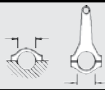
									
BE/PL	6	51.980/52.000	55.511/55.524	19.100	1.749	0.020/0.071	BS	4080CP	71-4218/6 STD 0.25
MB/HL 1-4	4	59.951/59.971	63.657/63.676	22.350	1.841	0.020/0.068	BS	4081CP	H1082/4 STD 0.25
SE/PB	1	21.994/22.000	25.120/25.146	23.720			BS	60014X	55-4280 SEMI

1324	 93.00	Petrol			
841 A.000	6 Cyl.	10:1	2959cc	158kW (215)PS	TD16733 687
AR 06430	6 Cyl.	10:1	2959cc	147kW (200)PS	TD64 690
AR 16199	6 Cyl.	10:1	2959cc	141kW (192)PS	TD23347
AR 19520	6 Cyl.	9.5:1	2959cc	136kW (185)PS	TD23345
AR 34302	6 Cyl.	10:1	2959cc	166kW (226)PS	TD23348 695
AR 61501	6 Cyl.	10:1	2959cc	151-155kW (205-211)PS	TD104 697
AR 64306	6 Cyl.	9.5:1	2959cc	132-170kW (180-231)PS	TD25829 702
AR 64307	6 Cyl.		2959cc	170kW (231)PS	TD148 703
AR 64308	6 Cyl.	10:1	2959cc	150-170kW (204-231)PS	TD126 704
AR 64399	6 Cyl.		2959cc	132-145kW (180-197)PS	TD21728 705
AR 66301	6 Cyl.		2959cc	152-155kW (207-211)PS	TD130 704
AR 66302	6 Cyl.		2959cc	151-155kW (205-211)PS	TD131 704
AR 66304	6 Cyl.	10:1	2959cc	169-171kW (230-233)PS	TD22624
AR 66306	6 Cyl.		2959cc	157kW (214)PS	TD21729 706
M 624 AA 30.A	6 Cyl.	9.5:1	2959cc	132-136kW (180-185)PS	TD22432
M 624 AB 30.A	6 Cyl.	10:1	2959cc	147kW (200)PS	TD22433

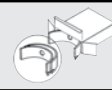
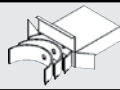
									
BE/PL	6	51.980/52.000	55.511/55.524	19.100	1.749	0.020/0.071	BS	4080CP	71-4218/6 STD 0.25
MB/HL 1-4	4	59.951/59.971	63.657/63.676	22.350	1.841	0.020/0.068	BS	4081CP	H1082/4 STD 0.25
SE/PB	1	21.994/22.000	25.120/25.146	23.720			BS	60014X	55-4280 SEMI

# FIAT GROUP







## 1325



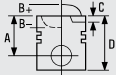
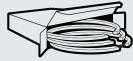







 93.00

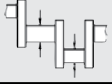



Petrol



AR 06120	6 Cyl.	9.5:1	2959cc	133-136kW (181-185)PS	TD48	688
AR 06124	6 Cyl.	9.5:1	2959cc	136-138kW (185-188)PS	TD49	688
AR 61503	6 Cyl.	9.5:1	2959cc	139-141kW (189-192)PS	TD51	688

			
	<b>08-527500-00</b> STD  1.50  CR P 1.50  P 3.50  P		

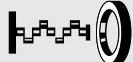
									
BE/PL	6	51.980/52.000	55.511/55.524	19.100	1.749	0.020/0.071	BS	4080CP	71-4218/6 STD 0.25
MB/HL 1-4	4	59.951/59.971	63.657/63.676	22.350	1.841	0.020/0.068	BS	4081CP	H1082/4 STD 0.25
SE/PB	1	21.994/22.000	25.120/25.146	23.720			BS	60014X	55-4280 SEMI

		
	JJ515	NA5163  32.00x47.00x10.00mm, FPM
		
	JJ515	







## 1326

 93.00

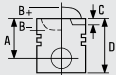
Petrol

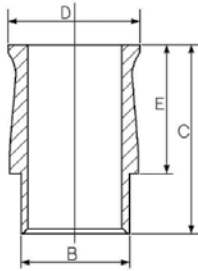

AR 06410	6 Cyl.		2959cc	136-141kW (184-192)PS	TD59	689
AR 06412	6 Cyl.		2959cc	135kW (184)PS	TD61	689
AR 64301	6 Cyl.	10:1	2959cc	147kW (200)PS	TD106	698

			
	<b>08-527500-00</b> STD  1.50  CR P 1.50  P 3.50  P	<b>15-632400-00</b> [9] B 99.00 C 119.00 D 109.00 E 78.00  	

[9] Includes seals









[9] Inclut des joints

[9] Comprende le guarnizioni

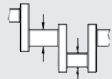
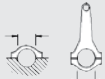





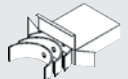

[9] Incluye los sellos



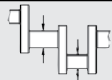
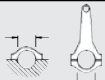



...Continued

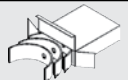







<b>1326</b>		 <b>93.00</b>	<b>Petrol</b>							
										
BE/PL	6	51.980/52.000	55.511/55.524	19.100	1.749	0.020/0.071	BS	4080CP	<b>71-4218/6</b> STD 0.25	
MB/HL 1-4	4	59.951/59.971	63.657/63.676	22.350	1.841	0.020/0.068	BS	4081CP	<b>H1082/4</b> STD 0.25	
SE/PB	1	21.994/22.000	25.120/25.146	23.720			BS	60014X	<b>55-4280</b> SEMI	

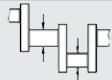
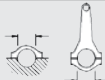

<b>1327</b>		 <b>93.00</b>	<b>Petrol</b>							
<b>AR 16101</b>	6 Cyl.	10:1	2959cc	<b>141kW (192)PS</b>			<b>TD4187</b>	<b>691</b>		
<b>AR 64305</b>	6 Cyl.		2959cc	<b>132kW (180)PS</b>			<b>TD125</b>	<b>701</b>		
<b>AR 66303</b>	6 Cyl.		2959cc	<b>132kW (180)PS</b>			<b>TD92</b>	<b>701</b>		

										
BE/PL	6	51.980/52.000	55.511/55.524	19.100	1.749	0.020/0.071	BS	4080CP	<b>71-4218/6</b> STD 0.25	
MB/HL 1-4	4	59.951/59.971	63.657/63.676	22.350	1.841	0.020/0.068	BS	4081CP	<b>H1082/4</b> STD 0.25	
SE/PB	1	21.994/22.000	25.120/25.146	23.720			BS	60014X	<b>55-4280</b> SEMI	

		
<b>NJ951</b>  32.00x50.00x8.00mm, FPM		

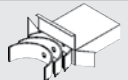
<b>1328</b>		 <b>93.00</b>	<b>Petrol</b>							
<b>AR 64304</b>	6 Cyl.		2959cc	<b>168-171kW (228-233)PS</b>			<b>TD124</b>	<b>700</b>		

										
BE/PL	6	51.980/52.000	55.511/55.524	19.100	1.749	0.020/0.071	BS	4080CP	<b>71-4218/6</b> STD 0.25	
MB/HL 1-4	4	59.951/59.971	63.657/63.676	22.350	1.841	0.020/0.068	BS	4081CP	<b>H1082/4</b> STD 0.25	
SE/PB	1	21.994/22.000	25.120/25.146	23.720			BS	60014X	<b>55-4280</b> SEMI	

		
<b>KV086</b>		



**KV086**











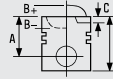
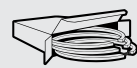

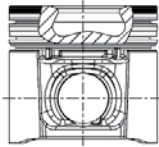
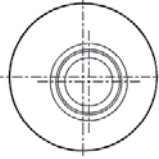

## 1329



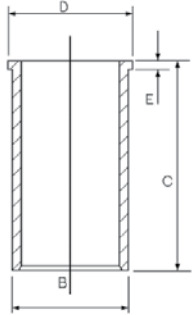

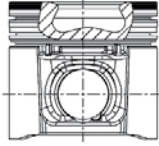
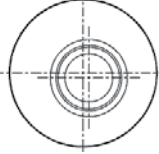



 94.40



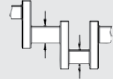
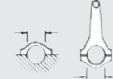



**Diesel**

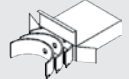

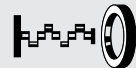

8140.23.	4 Cyl.	18.5:1	2798cc	76kW (103)PS	Turbo Intercooled	TD7229	710
8140.43.2585 Euro 2	4 Cyl.	18.5:1	2798cc	84-90kW (114-122)PS	Turbo Intercooled	TD20423	715
8140.43.3700 Euro 2	4 Cyl.	18.5:1	2798cc	85kW (116)PS	Turbo Intercooled	TD20424	715
8140.43.3900 Euro 2	4 Cyl.	18.5:1	2798cc	84-90kW (114-122)PS	Turbo Intercooled	TD20425	715





							
<b>87-122200-10</b> <b>87-122208-10</b>  STD 0.60mm  A 58.75 B- 19.40 BØ 39.25 D 87.60  32x72  AK KK RT TP	 	<b>08-122200-00</b> STD <b>08-122208-00</b> 0.60mm eng. 2572280 →  2.50  CK P 2.00  P 2.50  CR P	<b>14-021321-00 D</b> B 97.54 C 167.00 D 100.90 E 5.00 <b>14-021322-00 D</b> B 97.70 C 167.00 D 100.90 E 5.00 <b>14-028930-00 D</b> B 97.50 C 167.00 D 100.90 E 5.00 <b>14-028931-00 D</b> B 97.58 C 167.00 D 100.90 E 5.00 <b>14-028932-00 D</b> B 97.70 C 167.00 D 100.90 E 5.00				
<b>87-854700-00</b> <b>87-854708-00</b>  STD 0.60mm  A 58.75 B- 19.40 BØ 39.40 D 96.65  32x78  AK KK RT	 	<b>08-854700-00</b> STD <b>08-854708-00</b> 0.60mm eng. →2572279  3.00  CR 2.00  P 3.00  CR					



									
BE/PL	4	56.520/56.535	60.333/60.345	24.700	1.870	0.020/0.072	BS	1870CP	<b>71-4130/4</b> STD 0.25 0.50 0.75
MB/HL 5	1	86.182/86.208	90.588/90.614	30.950	2.164	0.052/0.129	BS	4691CPH	<b>H1104/5</b> STD 0.25 0.50
MB/HL 1-4	4	80.182/80.208	84.588/84.614	23.800	2.164	0.052/0.129	BS	4692CP	
SE/PB	1	31.990/31.996	34.895/34.920	30.700			BS	66579YA	<b>55-4186</b> SEMI

		
	JJ519   JJ519	NP067  50.00x70.00x10.00mm, FPM NF883  114.00x177.00x13.00mm, FPM NF885  70.00x179.00x16.00mm, FPM











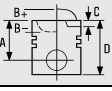

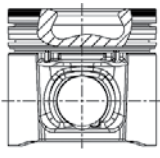
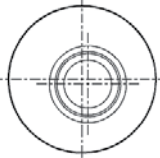

<b>1330</b>	 <b>94.40</b>	<b>Diesel</b>					
8140.23.2200	4 Cyl.	19:1	2800cc	<b>76kW (103)PS</b>	<b>Turbocharged</b>	<b>TD24996</b>	
8140.43P Euro 3 (D3)	4 Cyl.	18.5:1	2798cc	<b>78kW (106)PS</b>	<b>Turbo Intercooled</b>	<b>TD22680</b>	<b>728</b>



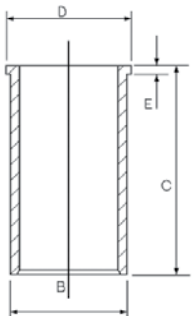

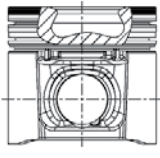

  

		
		<b>NF883</b>  114.00x177.00x13.00mm, FPM <b>NF885</b>  70.00x179.00x16.00mm, FPM

<b>1331</b>	 <b>94.40</b>	<b>Diesel</b>					
8140.23.2585 Euro 2	4 Cyl.	18.5:1	2799cc	<b>78kW (106)PS</b>	<b>Turbo Intercooled</b>	<b>TD16183</b>	<b>711</b>
8140.23.3700 Euro 2	4 Cyl.	18.5:1	2798cc	<b>76kW (103)PS</b>	<b>Turbo Intercooled</b>	<b>TD10387</b>	<b>711</b>

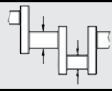
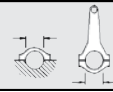
 <b>87-122200-10</b> <b>87-122208-10</b> STD 0.60mm  <b>A</b> 58.75 <b>B-</b> 19.40 <b>BØ</b> 39.25 <b>D</b> 87.60  32x72  <b>AK KK RT TP</b>	 	 <b>08-122200-00</b> STD <b>08-122208-00</b> 0.60mm eng. 2572280 →  2.50  <b>CK P</b> 2.00  <b>P</b> 2.50  <b>CR P</b>	 <b>14-021321-00 D</b> <b>B</b> 97.54 <b>C</b> 167.00 <b>D</b> 100.90 <b>E</b> 5.00 <b>14-021322-00 D</b> <b>B</b> 97.70 <b>C</b> 167.00 <b>D</b> 100.90 <b>E</b> 5.00 <b>14-028930-00 D</b> <b>B</b> 97.50 <b>C</b> 167.00 <b>D</b> 100.90 <b>E</b> 5.00 <b>14-028931-00 D</b> <b>B</b> 97.58 <b>C</b> 167.00 <b>D</b> 100.90 <b>E</b> 5.00 <b>14-028932-00 D</b> <b>B</b> 97.70 <b>C</b> 167.00 <b>D</b> 100.90 <b>E</b> 5.00  	
<b>87-854700-00</b> <b>87-854708-00</b> STD 0.60mm  <b>A</b> 58.75 <b>B-</b> 19.40 <b>BØ</b> 39.40 <b>D</b> 96.65  32x78  <b>AK KK RT</b>	 	<b>08-854700-00</b> STD <b>08-854708-00</b> 0.60mm eng. →2572279  3.00  <b>CR</b> 2.00  <b>P</b> 3.00  <b>CR</b>		

									
BE/PL	4	56.520/56.535	60.333/60.345	24.700	1.870	0.020/0.072	BS	1870CP	<b>71-4130/4</b> STD 0.25 0.50 0.75
MB/HL 5	1	86.182/86.208	90.588/90.614	30.950	2.164	0.052/0.129	BS	4691CPH	<b>H1104/5</b> STD 0.25 0.50
MB/HL 1-4	4	80.182/80.208	84.588/84.614	23.800	2.164	0.052/0.129	BS	4692CP	
SE/PB	1	31.990/31.996	34.895/34.920	30.700			BS	66579YA	<b>55-4186</b> SEMI

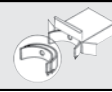
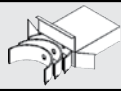

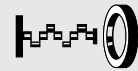

### 1331

 **94.40**
**Diesel**

**JH5178**  
Soft Material Gasket  
**JJ519**

**JH5178**

**JJ519**

**NF853**  100.00x118.00x10.00mm, FPM  
**NP067**  50.00x70.00x10.00mm, FPM  
**NF883**  114.00x177.00x13.00mm, FPM  
**NF885**  70.00x179.00x16.00mm, FPM  
**NF886**  100.00x179.00x15.80mm, FPM

### 1332

 **94.40**
**Diesel**

8140.23.3701 Euro 2	4 Cyl.	18.5:1	2798cc	76kW (103)PS	Turbo Intercooled	TD27373	712
8140.23.3710 Euro 2	4 Cyl.	18.5:1	2798cc	76kW (103)PS	Turbo Intercooled	TD27374	712
8140.23.3711 Euro 2	4 Cyl.	18.5:1	2798cc	76kW (103)PS	Turbo Intercooled	TD27375	712
8140.23.3713 Euro 2	4 Cyl.	18.5:1	2798cc	76kW (103)PS	Turbo Intercooled	TD27376	712
8140.23.3720 Euro 2	4 Cyl.	18.5:1	2798cc	76kW (103)PS	Turbo Intercooled	TD27377	712
8140.23.3721 Euro 2	4 Cyl.	18.5:1	2798cc	76kW (103)PS	Turbo Intercooled	TD27378	712
8140.23.3730 Euro 2	4 Cyl.	18.5:1	2798cc	76kW (103)PS	Turbo Intercooled	TD27379	712
8140.23.3731 Euro 2	4 Cyl.	18.5:1	2798cc	76kW (103)PS	Turbo Intercooled	TD27380	712
8140.23.3750 Euro 2	4 Cyl.	18.5:1	2798cc	76kW (103)PS	Turbo Intercooled	TD27381	712
8140.23.3751 Euro 2	4 Cyl.	18.5:1	2798cc	76kW (103)PS	Turbo Intercooled	TD27382	712
8140.23.3760 Euro 2	4 Cyl.	18.5:1	2798cc	76kW (103)PS	Turbo Intercooled	TD27383	713
8140.23.3801 Euro 2	4 Cyl.	18.5:1	2798cc	76kW (103)PS	Turbo Intercooled	TD27384	714
8140.23.3811 Euro 2	4 Cyl.	18.5:1	2798cc	76kW (103)PS	Turbo Intercooled	TD27385	714
8140.23.3821 Euro 2	4 Cyl.	18.5:1	2798cc	76kW (103)PS	Turbo Intercooled	TD27386	714
8140.43.3711 Euro 2	4 Cyl.	18.5:1	2798cc	90kW (122)PS	Turbo Intercooled	TD27427	
8140.43.3713 Euro 2	4 Cyl.	18.5:1	2798cc	90kW (122)PS	Turbo Intercooled	TD27428	
8140.43.3718 Euro 2	4 Cyl.	18.5:1	2798cc	90kW (122)PS	Turbo Intercooled	TD27429	
8140.43.3721 Euro 2	4 Cyl.	18.5:1	2798cc	90kW (122)PS	Turbo Intercooled	TD27430	
8140.43.3723 Euro 2	4 Cyl.	18.5:1	2798cc	90kW (122)PS	Turbo Intercooled	TD27431	
8140.43.3728 Euro 2	4 Cyl.	18.5:1	2798cc	77-85kW (105-116)PS	Turbo Intercooled	TD27432	716
8140.43.3731 Euro 2	4 Cyl.	18.5:1	2798cc	90kW (122)PS	Turbo Intercooled	TD27433	
8140.43.3911 Euro 2	4 Cyl.	18.5:1	2798cc	90kW (122)PS	Turbo Intercooled	TD27434	
8140.43.3921 Euro 2	4 Cyl.	18.5:1	2798cc	90kW (122)PS	Turbo Intercooled	TD27435	
8140.43.3931 Euro 2	4 Cyl.	18.5:1	2798cc	90kW (122)PS	Turbo Intercooled	TD27436	
8140.43.K	4 Cyl.		2798cc	103kW (140)PS	Turbo Intercooled	TD28051	
8140.43C.4000 Euro 3 (D3)	4 Cyl.	18.5:1	2798cc	77kW (105)PS	Turbo Intercooled	TD25972	718
8140.43C.4005 Euro 3 (D3)	4 Cyl.	18.5:1	2798cc	77kW (105)PS	Turbo Intercooled	TD25973	718
8140.43C.4020 Euro 3 (D3)	4 Cyl.	18.5:1	2798cc	77kW (105)PS	Turbo Intercooled	TD25974	721
8140.43C.4021 Euro 3 (D3)	4 Cyl.	18.5:1	2798cc	77kW (105)PS	Turbo Intercooled	TD25975	721
8140.43C.4025 Euro 3 (D3)	4 Cyl.	18.5:1	2798cc	77kW (105)PS	Turbo Intercooled	TD25976	718
8140.43C.4026 Euro 3 (D3)	4 Cyl.	18.5:1	2798cc	77kW (105)PS	Turbo Intercooled	TD25977	718
8140.43C.4030 Euro 3 (D3)	4 Cyl.	18.5:1	2798cc	77kW (105)PS	Turbo Intercooled	TD25978	722
8140.43C.4031 Euro 3 (D3)	4 Cyl.	18.5:1	2798cc	77kW (105)PS	Turbo Intercooled	TD25979	722
8140.43C.4035 Euro 3 (D3)	4 Cyl.	18.5:1	2798cc	77kW (105)PS	Turbo Intercooled	TD25980	723
8140.43C.4036 Euro 3 (D3)	4 Cyl.	18.5:1	2798cc	77kW (105)PS	Turbo Intercooled	TD25981	719
8140.43K.4020 Euro 3 (D3)	4 Cyl.	18.5:1	2798cc	92kW (125)PS	Turbo Intercooled	TD25982	718
8140.43K.4030 Euro 3 (D3)	4 Cyl.	18.5:1	2798cc	92kW (125)PS	Turbo Intercooled	TD25983	
8140.43R.4300 Euro 3 (D3)	4 Cyl.	18.5:1	2798cc	66kW (90)PS	Turbo Intercooled	TD25989	712
8140.43R.4320 Euro 3 (D3)	4 Cyl.	18.5:1	2798cc	66kW (90)PS	Turbo Intercooled	TD25990	712
8140.43R.4330 Euro 3 (D3)	4 Cyl.	18.5:1	2798cc	66kW (90)PS	Turbo Intercooled	TD25991	712
8140.43R.4400 Euro 3 (D3)	4 Cyl.	18.5:1	2798cc	66kW (90)PS	Turbo Intercooled	TD25992	712

...Continued

1332		94.40		Diesel						
8140.43R.4420 Euro 3 (D3)	4 Cyl.	18.5:1	2798cc	66kW (90)PS	Turbo Intercooled	TD25993	712			
8140.43R.4430 Euro 3 (D3)	4 Cyl.	18.5:1	2798cc	66kW (90)PS	Turbo Intercooled	TD25994	729			
BE/PL	4	56.520/56.535	60.333/60.345	24.700	1.870	0.020/0.072	BS	1870CP	71-4130/4 STD 0.25 0.50 0.75	
MB/HL 5	1	86.182/86.208	90.588/90.614	30.950	2.164	0.052/0.129	BS	4691CPH	H1104/5 STD 0.25 0.50	
MB/HL 1-4	4	80.182/80.208	84.588/84.614	23.800	2.164	0.052/0.129	BS	4692CP		
SE/PB	1	31.990/31.996	34.895/34.920	30.700			BS	66579YA	55-4186 SEMI	

1333		94.40		Diesel						
8140.43. Euro 2	4 Cyl.	18.5:1	2798cc	90kW (122)PS	Turbo Intercooled	TD7235	717			
87-122200-10 87-122208-10	STD 0.60mm			87-122200-00 87-122208-00 eng. 2572280 →	STD 0.60mm			14-021321-00 D 14-021322-00 D 14-028930-00 D 14-028931-00 D 14-028932-00 D		
A 58.75 B- 19.40 BØ 39.25 D 87.60 				2.50  CK P 2.00  P 2.50  CR P				B 97.54 C 167.00 D 100.90 E 5.00 B 97.70 C 167.00 D 100.90 E 5.00 B 97.50 C 167.00 D 100.90 E 5.00 B 97.58 C 167.00 D 100.90 E 5.00 B 97.70 C 167.00 D 100.90 E 5.00		
AK KK RT TP										
87-854700-00 87-854708-00	STD 0.60mm			87-854700-00 87-854708-00 eng. →2572279	STD 0.60mm					
A 58.75 B- 19.40 BØ 39.40 D 96.65 				3.00  CR 2.00  P 3.00  CR						
AK KK RT										
				JJ519			NP067  50.00x70.00x10.00mm, FPM NF883  114.00x177.00x13.00mm, FPM NF885  70.00x179.00x16.00mm, FPM			
				JJ519						

## 1334

### 94.40

### Diesel



8140.43B.4300 Euro 3 (D3)	4 Cyl.	18:1	2798cc	77kW (105)PS	Turbo Intercooled	TD25968	718
8140.43B.4305 Euro 3 (D3)	4 Cyl.	18:1	2798cc	77kW (105)PS	Turbo Intercooled	TD25966	718
8140.43B.4320 Euro 3 (D3)	4 Cyl.	18:1	2798cc	77kW (105)PS	Turbo Intercooled	TD25967	719
8140.43B.4325 Euro 3 (D3)	4 Cyl.	18:1	2798cc	77kW (105)PS	Turbo Intercooled	TD25969	718
8140.43B.4330 Euro 3 (D3)	4 Cyl.	18:1	2798cc	77kW (105)PS	Turbo Intercooled	TD25970	718
8140.43B.4335 Euro 3 (D3)	4 Cyl.	18:1	2798cc	77kW (105)PS	Turbo Intercooled	TD25971	718

<b>87-122200-20</b> STD <b>A</b> 58.75 <b>B-</b> 23.35 <b>BØ</b> 39.30 <b>D</b> 87.60 32x72 <b>AK RT TP</b>	<b>08-122200-00</b> STD <b>08-122208-00</b> 0.60mm  2.50  CK P 2.00  P 2.50  CR P	<b>14-021321-00 D</b> <b>B</b> 97.54 <b>C</b> 167.00 <b>D</b> 100.90 <b>E</b> 5.00 <b>14-021322-00 D</b> <b>B</b> 97.70 <b>C</b> 167.00 <b>D</b> 100.90 <b>E</b> 5.00 <b>14-028930-00 D</b> <b>B</b> 97.50 <b>C</b> 167.00 <b>D</b> 100.90 <b>E</b> 5.00 <b>14-028931-00 D</b> <b>B</b> 97.58 <b>C</b> 167.00 <b>D</b> 100.90 <b>E</b> 5.00 <b>14-028932-00 D</b> <b>B</b> 97.70 <b>C</b> 167.00 <b>D</b> 100.90 <b>E</b> 5.00						

BE/PL	4	56.520/56.535	60.333/60.345	24.700	1.870	0.020/0.072	BS	1870CP	<b>71-4130/4</b> STD 0.25 0.50 0.75	
MB/HL 5	1	86.182/86.208	90.588/90.614	30.950	2.164	0.052/0.129	BS	4691CPH	<b>H1104/5</b> STD 0.25 0.50	
MB/HL 1-4	4	80.182/80.208	84.588/84.614	23.800	2.164	0.052/0.129	BS	4692CP		
SE/PB	1	31.990/31.996	34.895/34.920	30.700			BS	66579YA	<b>55-4186</b> SEMI	

## 1335

## 94.40

## Diesel



8140.43B Euro 3 (D3)

4 Cyl.

18.5:1

2798cc

78kW (105)PS

Turbo Intercooled

TD16514

720

<p><b>87-122200-20</b>      STD</p> <p><b>A</b>    58.75  <b>B-</b>    23.35  <b>BØ</b>    39.30  <b>D</b>     87.60   32x72</p> <p><b>AK RT TP</b></p>	 	<p><b>08-122200-00</b>    STD  <b>08-122208-00</b>    0.60mm</p> <p>2.50  CK P  2.00  P  2.50  CR P</p>	<p><b>14-021321-00 D</b>  <b>B</b> 97.54    <b>C</b> 167.00    <b>D</b> 100.90    <b>E</b> 5.00  <b>14-021322-00 D</b>  <b>B</b> 97.70    <b>C</b> 167.00    <b>D</b> 100.90    <b>E</b> 5.00  <b>14-028930-00 D</b>  <b>B</b> 97.50    <b>C</b> 167.00    <b>D</b> 100.90    <b>E</b> 5.00  <b>14-028931-00 D</b>  <b>B</b> 97.58    <b>C</b> 167.00    <b>D</b> 100.90    <b>E</b> 5.00  <b>14-028932-00 D</b>  <b>B</b> 97.70    <b>C</b> 167.00    <b>D</b> 100.90    <b>E</b> 5.00</p>

BE/PL	4	56.520/56.535	60.333/60.345	24.700	1.870	0.020/0.072	BS	1870CP	<b>71-4130/4</b> STD 0.25 0.50 0.75
MB/HL 5	1	86.182/86.208	90.588/90.614	30.950	2.164	0.052/0.129	BS	4691CPH	<b>H1104/5</b> STD 0.25 0.50
MB/HL 1-4	4	80.182/80.208	84.588/84.614	23.800	2.164	0.052/0.129	BS	4692CP	
SE/PB	1	31.990/31.996	34.895/34.920	30.700			BS	66579YA	<b>55-4186</b> SEMI

	<p><b>JJ613</b></p> <p><b>JJ613</b></p>	<p><b>NF883</b>  114.00x177.00x13.00mm, FPM  <b>NF885</b>  70.00x179.00x16.00mm, FPM</p>

## 1336

### 94.40

### Diesel



8140.43C Euro 2

4 Cyl.







2798cc



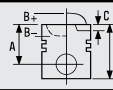
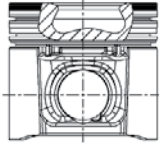
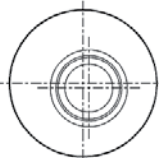
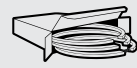

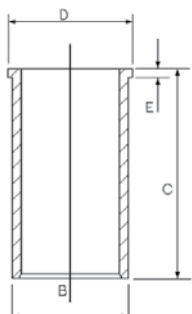

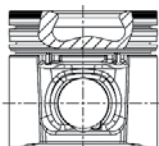

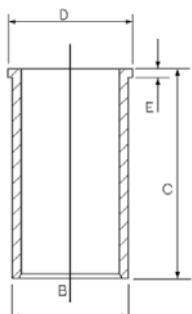

78kW (106)PS

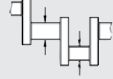

Turbo Intercooled

TD14449

724

 <p><b>87-122200-10</b> <b>87-122208-10</b></p> <p>STD 0.60mm</p>   <p>A 58.75 B- 19.40 Bø 39.25 D 87.60 32x72</p> <p>AK KK RT TP</p>	 <p><b>08-122200-00</b> STD <b>08-122208-00</b> 0.60mm eng. 2572280→</p> <p>2.50 CK P 2.00 P 2.50 CR P</p> 	 <p><b>14-021321-00 D</b> B 97.54 C 167.00 D 100.90 E 5.00 <b>14-021322-00 D</b> B 97.70 C 167.00 D 100.90 E 5.00 <b>14-028930-00 D</b> B 97.50 C 167.00 D 100.90 E 5.00 <b>14-028931-00 D</b> B 97.58 C 167.00 D 100.90 E 5.00 <b>14-028932-00 D</b> B 97.70 C 167.00 D 100.90 E 5.00</p> 	
<p><b>87-854700-00</b> <b>87-854708-00</b></p> <p>STD 0.60mm</p>   <p>A 58.75 B- 19.40 Bø 39.40 D 96.65 32x78</p> <p>AK KK RT</p>	<p><b>08-854700-00</b> STD <b>08-854708-00</b> 0.60mm eng. →2572279</p> <p>3.00 CR 2.00 P 3.00 CR</p> 		

									
BE/PL	4	56.520/56.535	60.333/60.345	24.700	1.870	0.020/0.072	BS	1870CP	<b>71-4130/4</b> STD 0.25 0.50 0.75
MB/HL 5	1	86.182/86.208	90.588/90.614	30.950	2.164	0.052/0.129	BS	4691CPH	<b>H1104/5</b> STD 0.25 0.50
MB/HL 1-4	4	80.182/80.208	84.588/84.614	23.800	2.164	0.052/0.129	BS	4692CP	
SE/PB	1	31.990/31.996	34.895/34.920	30.700			BS	66579YA	<b>55-4186</b> SEMI

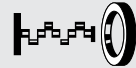
 <p><b>JJ613</b></p>  <p><b>JJ613</b></p>		 <p><b>NP067</b> 50.00x70.00x10.00mm, FPM <b>NF883</b> 114.00x177.00x13.00mm, FPM <b>NF885</b> 70.00x179.00x16.00mm, FPM</p>
---	---	---



<b>1337</b>	<b>94.40</b>	<b>Diesel</b>					
8140.43K.4000 Euro 3 (D3)	4 Cyl.	18.5:1	2798cc	107kW (146)PS	Turbo Intercooled	TD17143	<b>725</b>

	JJ613	<b>NP067</b> 50.00x70.00x10.00mm, FPM <b>NF883</b> 114.00x177.00x13.00mm, FPM <b>NF885</b> 70.00x179.00x16.00mm, FPM
		JJ613

<b>1338</b>	<b>94.40</b>	<b>Diesel</b>					
8140.43N.4300 Euro 3 (D3)	4 Cyl.	18.5:1	2798cc	108kW (147)PS	Turbo Intercooled	TD25984	<b>712</b>
8140.43N.4320 Euro 3 (D3)	4 Cyl.	18.5:1	2798cc	108kW (147)PS	Turbo Intercooled	TD25985	<b>712</b>
8140.43N.4330 Euro 3 (D3)	4 Cyl.	18.5:1	2798cc	108kW (147)PS	Turbo Intercooled	TD25986	<b>712</b>
8140.43N.4400 Euro 3 (D3)	4 Cyl.	18.5:1	2798cc	108kW (147)PS	Turbo Intercooled	TD25987	<b>712</b>
8140.43N.4430 Euro 3 (D3)	4 Cyl.	18.5:1	2798cc	108kW (147)PS	Turbo Intercooled	TD25988	<b>712</b>
8140.43S.4000 Euro 3 (D3)	4 Cyl.	18.5:1	2798cc	92kW (125)PS	Turbo Intercooled	TD25995	<b>712</b>
8140.43S.4020 Euro 3 (D3)	4 Cyl.	18.5:1	2798cc	92kW (125)PS	Turbo Intercooled	TD25996	<b>712</b>
8140.43S.4030 Euro 3 (D3)	4 Cyl.	18.5:1	2798cc	92kW (125)PS	Turbo Intercooled	TD25997	<b>712</b>
8140.43S.4140 Euro 3 (D3)	4 Cyl.	18.5:1	2798cc	92kW (125)PS	Turbo Intercooled	TD25998	<b>712</b>
8140.43S.4300 Euro 3 (D3)	4 Cyl.	18.5:1	2798cc	92kW (125)PS	Turbo Intercooled	TD25999	<b>712</b>
8140.43S.4320 Euro 3 (D3)	4 Cyl.	18.5:1	2798cc	92kW (125)PS	Turbo Intercooled	TD26000	<b>712</b>
8140.43S.4330 Euro 3 (D3)	4 Cyl.	18.5:1	2798cc	92kW (125)PS	Turbo Intercooled	TD26001	<b>712</b>
8140.43S.4400 Euro 3 (D3)	4 Cyl.	18.5:1	2798cc	92kW (125)PS	Turbo Intercooled	TD26002	<b>712</b>
8140.43S.4420 Euro 3 (D3)	4 Cyl.	18.5:1	2798cc	92kW (125)PS	Turbo Intercooled	TD26003	<b>712</b>
8140.43S.4430 Euro 3 (D3)	4 Cyl.	18.5:1	2798cc	92kW (125)PS	Turbo Intercooled	TD26004	<b>712</b>

<b>87-122200-00</b> STD <b>87-122208-00</b> 0.60mm  <b>A</b> 58.70 <b>B-</b> 21.30 <b>BØ</b> 39.40 <b>D</b> 87.60 32x72  <b>AK KK RT TP</b>	<b>08-122200-00</b> STD <b>08-122208-00</b> 0.60mm  2.50  CK P 2.00  P 2.50  CR P	<b>14-021321-00 D</b> <b>B</b> 97.54 <b>C</b> 167.00 <b>D</b> 100.90 <b>E</b> 5.00 <b>14-021322-00 D</b> <b>B</b> 97.70 <b>C</b> 167.00 <b>D</b> 100.90 <b>E</b> 5.00 <b>14-028930-00 D</b> <b>B</b> 97.50 <b>C</b> 167.00 <b>D</b> 100.90 <b>E</b> 5.00 <b>14-028931-00 D</b> <b>B</b> 97.58 <b>C</b> 167.00 <b>D</b> 100.90 <b>E</b> 5.00 <b>14-028932-00 D</b> <b>B</b> 97.70 <b>C</b> 167.00 <b>D</b> 100.90 <b>E</b> 5.00	



1338		94.40		Diesel					
BE/PL	4	56.520/56.535	60.333/60.345	24.700	1.870	0.020/0.072	BS	1870CP	<b>71-4130/4</b> STD 0.25 0.50 0.75
MB/HL 5	1	86.182/86.208	90.588/90.614	30.950	2.164	0.052/0.129	BS	4691CPH	<b>H1104/5</b> STD 0.25 0.50
MB/HL 1-4	4	80.182/80.208	84.588/84.614	23.800	2.164	0.052/0.129	BS	4692CP	
SE/PB	1	31.990/31.996	34.895/34.920	30.700			BS	66579YA	<b>55-4186</b> SEMI

1339		94.40		Diesel					
<b>8140.43N Euro 3 (D3)</b>	4 Cyl.	18.5:1	2798cc	<b>107kW (146)PS</b>	<b>Turbo Intercooled</b>			<b>TD16873</b>	<b>727</b>
<b>8140.43S Euro 3 (D3)</b>	4 Cyl.	18.5:1	2798cc	<b>92-100kW (125-136)PS</b>	<b>Turbo Intercooled</b>			<b>TD16874</b>	<b>732</b>







87-122200-00		87-122208-00		08-122200-00		08-122208-00		14-021321-00 D		14-021322-00 D		14-028930-00 D		14-028931-00 D		14-028932-00 D			
STD	0.60mm	STD	0.60mm	2.50	2.00	2.50	2.50	B 97.54	C 167.00	D 100.90	E 5.00	B 97.70	C 167.00	D 100.90	E 5.00	B 97.50	C 167.00	D 100.90	E 5.00
A 58.70	B- 21.30	BØ 39.40	D 87.60	CK P	P	CR P		B 97.58	C 167.00	D 100.90	E 5.00	B 97.70	C 167.00	D 100.90	E 5.00				
AK KK RT TP																			



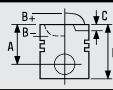
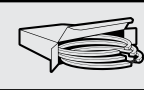

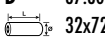
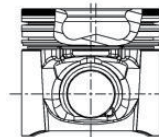
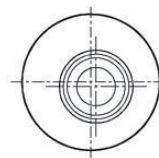

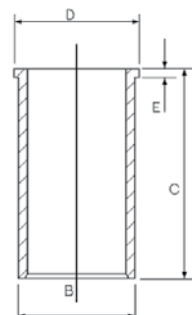

1338		94.40		Diesel					
BE/PL	4	56.520/56.535	60.333/60.345	24.700	1.870	0.020/0.072	BS	1870CP	<b>71-4130/4</b> STD 0.25 0.50 0.75
MB/HL 5	1	86.182/86.208	90.588/90.614	30.950	2.164	0.052/0.129	BS	4691CPH	<b>H1104/5</b> STD 0.25 0.50
MB/HL 1-4	4	80.182/80.208	84.588/84.614	23.800	2.164	0.052/0.129	BS	4692CP	
SE/PB	1	31.990/31.996	34.895/34.920	30.700			BS	66579YA	<b>55-4186</b> SEMI



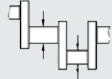
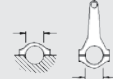

JJ613		NP067		NF883		NF885	
JJ613		NP067	50.00x70.00x10.00mm, FPM	NF883	114.00x177.00x13.00mm, FPM	NF885	70.00x179.00x16.00mm, FPM

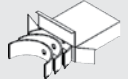

**1340**  **94.40 Diesel** 

**8140.43N Euro 3 (D3)** 4 Cyl. 18.5:1 2798cc **107kW (146)PS** Turbo Intercooled **TD20450 726**









			
<b>87-122200-00</b> STD <b>87-122208-00</b> 0.60mm  <b>A</b> 58.70 <b>B-</b> 21.30 <b>BØ</b> 39.40 <b>D</b> 87.60  32x72  <b>AK KK RT TP</b>	  	<b>08-122200-00</b> STD <b>08-122208-00</b> 0.60mm  2.50  CK P 2.00  P 2.50  CR P	<b>14-021321-00 D</b> <b>B</b> 97.54 <b>C</b> 167.00 <b>D</b> 100.90 <b>E</b> 5.00 <b>14-021322-00 D</b> <b>B</b> 97.70 <b>C</b> 167.00 <b>D</b> 100.90 <b>E</b> 5.00 <b>14-028930-00 D</b> <b>B</b> 97.50 <b>C</b> 167.00 <b>D</b> 100.90 <b>E</b> 5.00 <b>14-028931-00 D</b> <b>B</b> 97.58 <b>C</b> 167.00 <b>D</b> 100.90 <b>E</b> 5.00 <b>14-028932-00 D</b> <b>B</b> 97.70 <b>C</b> 167.00 <b>D</b> 100.90 <b>E</b> 5.00  

									
BE/PL	4	56.520/56.535	60.333/60.345	24.700	1.870	0.020/0.072	BS	1870CP	<b>71-4130/4</b> STD 0.25 0.50 0.75
MB/HL 5	1	86.182/86.208	90.588/90.614	30.950	2.164	0.052/0.129	BS	4691CPH	<b>H1104/5</b> STD 0.25 0.50
MB/HL 1-4	4	80.182/80.208	84.588/84.614	23.800	2.164	0.052/0.129	BS	4692CP	
SE/PB	1	31.990/31.996	34.895/34.920	30.700			BS	66579YA	<b>55-4186</b> SEMI

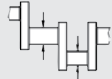
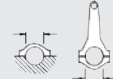



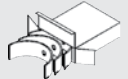

		
		<b>NF883</b>  114.00x177.00x13.00mm, FPM <b>NF885</b>  70.00x179.00x16.00mm, FPM

**1341**  **94.40 Diesel** 

**8140.43R Euro 3 (D3)** 4 Cyl. 18.5:1 2798cc **66kW (90)PS** Turbo Intercooled **TD18570 730**

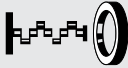







									
BE/PL	4	56.520/56.535	60.333/60.345	24.700	1.870	0.020/0.072	BS	1870CP	<b>71-4130/4</b> STD 0.25 0.50 0.75
MB/HL 5	1	86.182/86.208	90.588/90.614	30.950	2.164	0.052/0.129	BS	4691CPH	<b>H1104/5</b> STD 0.25 0.50
MB/HL 1-4	4	80.182/80.208	84.588/84.614	23.800	2.164	0.052/0.129	BS	4692CP	
SE/PB	1	31.990/31.996	34.895/34.920	30.700			BS	66579YA	<b>55-4186</b> SEMI

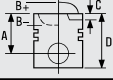
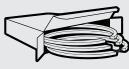

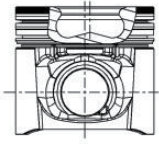

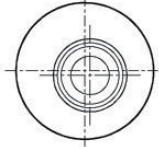

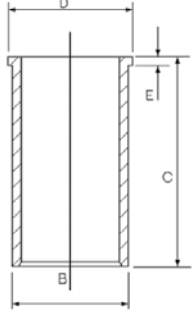

**1341**  **94.40 Diesel**



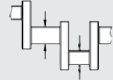
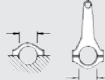

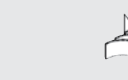
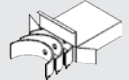

		
	<p><b>JJ613</b></p>  <p><b>JJ613</b></p>	<p><b>NP067</b>  50.00x70.00x10.00mm, FPM  <b>NF883</b>  114.00x177.00x13.00mm, FPM  <b>NF885</b>  70.00x179.00x16.00mm, FPM</p>

**1342**  **94.40 Diesel** 

8140.43S      4 Cyl.      18.5:1      2798cc      94kW (128)PS      Turbo Intercooled      TD16196      **731**

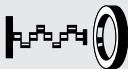
			
<p><b>87-122200-00</b>      STD  <b>87-122208-00</b>      0.60mm</p>  <p><b>A</b> 58.70  <b>B-</b> 21.30  <b>BØ</b> 39.40  <b>D</b> 87.60   32x72</p> <p><b>AK KK RT TP</b></p> 	<p><b>08-122200-00</b>      STD  <b>08-122208-00</b>      0.60mm</p> <p>2.50  <b>CK P</b>  2.00  <b>P</b>  2.50  <b>CR P</b></p>	<p><b>14-021321-00 D</b>  <b>B</b> 97.54    <b>C</b> 167.00    <b>D</b> 100.90    <b>E</b> 5.00  <b>14-021322-00 D</b>  <b>B</b> 97.70    <b>C</b> 167.00    <b>D</b> 100.90    <b>E</b> 5.00  <b>14-028930-00 D</b>  <b>B</b> 97.50    <b>C</b> 167.00    <b>D</b> 100.90    <b>E</b> 5.00  <b>14-028931-00 D</b>  <b>B</b> 97.58    <b>C</b> 167.00    <b>D</b> 100.90    <b>E</b> 5.00  <b>14-028932-00 D</b>  <b>B</b> 97.70    <b>C</b> 167.00    <b>D</b> 100.90    <b>E</b> 5.00</p> 	

										
BE/PL	4	56.520/56.535	60.333/60.345	24.700	1.870	0.020/0.072	BS	1870CP	<b>71-4130/4</b> STD 0.25 0.50 0.75	
MB/HL 5	1	86.182/86.208	90.588/90.614	30.950	2.164	0.052/0.129	BS	4691CPH	<b>H1104/5</b> STD 0.25 0.50	
MB/HL 1-4	4	80.182/80.208	84.588/84.614	23.800	2.164	0.052/0.129	BS	4692CP		
SE/PB	1	31.990/31.996	34.895/34.920	30.700			BS	66579YA	<b>55-4186</b> SEMI	

		
	<p><b>JH5178</b> Soft Material Gasket <b>JJ613</b></p>   <p><b>JH5178</b>      <b>JJ613</b></p>	<p><b>NF883</b>  114.00x177.00x13.00mm, FPM  <b>NF885</b>  70.00x179.00x16.00mm, FPM</p>

## 1343

## 94.40

## Diesel



8140.63. Euro 2	4 Cyl.	21.7:1	2798cc	62kW (84)PS		TD10389	734
8140.63.4000 Euro 3 (D3)	4 Cyl.	21.7:1	2798cc	62kW (84)PS	Turbo Intercooled	TD20478	733

<b>87-108200-00</b> <b>87-108208-00</b>  STD 0.60mm  A 55.00 B- 2.80 D 90.00 32x68  AK HA RT TP	<b>08-108200-00</b> STD <b>08-108208-00</b> 0.60mm  3.00  CR P 2.00  P 2.50  CR P	<b>14-021321-00 D</b> B 97.54 C 167.00 D 100.90 E 5.00 <b>14-021322-00 D</b> B 97.70 C 167.00 D 100.90 E 5.00 <b>14-028930-00 D</b> B 97.50 C 167.00 D 100.90 E 5.00 <b>14-028931-00 D</b> B 97.58 C 167.00 D 100.90 E 5.00 <b>14-028932-00 D</b> B 97.70 C 167.00 D 100.90 E 5.00  	

BE/PL	4	56.520/56.535	60.333/60.345	24.700	1.870	0.020/0.072	BS	1870CP	<b>71-4130/4</b> STD 0.25 0.50 0.75
MB/HL 5	1	86.182/86.208	90.588/90.614	30.950	2.164	0.052/0.129	BS	4691CPH	<b>H1104/5</b> STD 0.25 0.50
MB/HL 1-4	4	80.182/80.208	84.588/84.614	23.800	2.164	0.052/0.129	BS	4692CP	
SE/PB	1	31.990/31.996	34.895/34.920	30.700			BS	66579YA	<b>55-4186</b> SEMI

	JJ613  	NP067  50.00x70.00x10.00mm, FPM NF883  114.00x177.00x13.00mm, FPM NF885  70.00x179.00x16.00mm, FPM











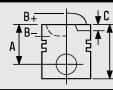
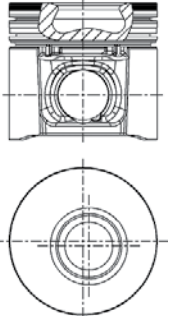

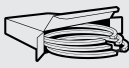
## 1344



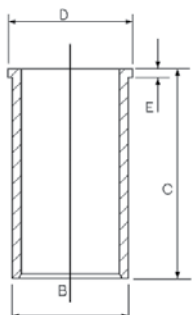

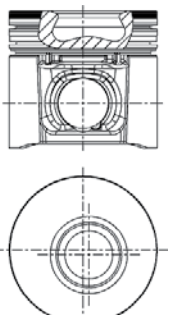



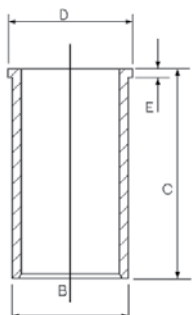

 94.40

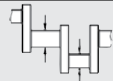

**Diesel**

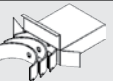

8140.43      4 Cyl.      18.5:1      2800cc      90kW (122)PS      Turbocharged      TD11769      736

 <p><b>87-122200-10</b> <b>87-122208-10</b></p> <p>STD 0.60mm</p>  <p>A 58.75 B- 19.40 BØ 39.25 D 87.60  32x72</p> <p>AK KK RT TP</p>	 <p><b>08-122200-00</b> STD <b>08-122208-00</b> 0.60mm eng. 2572280→</p> <p>2.50  CK P 2.00  P 2.50  CR P</p>	 <p><b>14-021321-00 D</b> B 97.54 C 167.00 D 100.90 E 5.00 <b>14-021322-00 D</b> B 97.70 C 167.00 D 100.90 E 5.00 <b>14-028930-00 D</b> B 97.50 C 167.00 D 100.90 E 5.00 <b>14-028931-00 D</b> B 97.58 C 167.00 D 100.90 E 5.00 <b>14-028932-00 D</b> B 97.70 C 167.00 D 100.90 E 5.00</p> 	
<p><b>87-854700-00</b> <b>87-854708-00</b></p> <p>STD 0.60mm</p>  <p>A 58.75 B- 19.40 BØ 39.40 D 96.65  32x78</p> <p>AK KK RT</p>	<p><b>08-854700-00</b> STD <b>08-854708-00</b> 0.60mm eng. →2572279</p> <p>3.00  CR 2.00  P 3.00  CR</p>		



										
BE/PL	4	56.520/56.535	60.333/60.345	24.700	1.870	0.020/0.072	BS	1870CP	<b>71-4130/4</b> STD 0.25 0.50 0.75	
MB/HL 5	1	86.182/86.208	90.588/90.614	30.950	2.164	0.052/0.129	BS	4691CPH	<b>H1104/5</b> STD 0.25 0.50	
MB/HL 1-4	4	80.182/80.208	84.588/84.614	23.800	2.164	0.052/0.129	BS	4692CP		
SE/PB	1	31.990/31.996	34.895/34.920	30.700			BS	66579YA	<b>55-4186</b> SEMI	

		
---	---	---

**JH5178**  
Soft Material Gasket



JH5178

**NF883**  114.00x177.00x13.00mm, FPM  
**NF885**  70.00x179.00x16.00mm, FPM

## 1345

### 94.40

### Diesel



8140.63

4 Cyl.

21:1

2800cc

64kW (87)PS

TD12749

737

<p><b>87-108200-00</b> STD <b>87-108208-00</b> 0.60mm</p> <p>A 55.00 B- 2.80 D 90.00 32x68</p> <p>AK HA RT TP</p>	<p><b>08-108200-00</b> STD <b>08-108208-00</b> 0.60mm</p> <p>3.00 CR P 2.00 P 2.50 CR P</p>	<p><b>14-021321-00 D</b> B 97.54 C 167.00 D 100.90 E 5.00 <b>14-021322-00 D</b> B 97.70 C 167.00 D 100.90 E 5.00 <b>14-028930-00 D</b> B 97.50 C 167.00 D 100.90 E 5.00 <b>14-028931-00 D</b> B 97.58 C 167.00 D 100.90 E 5.00 <b>14-028932-00 D</b> B 97.70 C 167.00 D 100.90 E 5.00</p>	

BE/PL	4	56.520/56.535	60.333/60.345	24.700	1.870	0.020/0.072	BS	1870CP	<b>71-4130/4</b> STD 0.25 0.50 0.75
MB/HL 5	1	86.182/86.208	90.588/90.614	30.950	2.164	0.052/0.129	BS	4691CPH	<b>H1104/5</b> STD 0.25 0.50
MB/HL 1-4	4	80.182/80.208	84.588/84.614	23.800	2.164	0.052/0.129	BS	4692CP	
SE/PB	1	31.990/31.996	34.895/34.920	30.700			BS	66579YA	<b>55-4186</b> SEMI

	<p><b>JH5178</b> Soft Material Gasket <b>JJ613</b></p> <p> <b>JH5178</b></p> <p> <b>JJ613</b></p>	<p><b>NF883</b> 114.00x177.00x13.00mm, FPM <b>NF885</b> 70.00x179.00x16.00mm, FPM</p>









## 1346

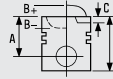



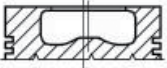
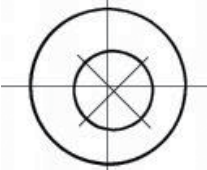

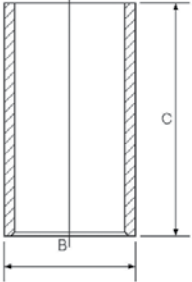

 95.00

**Diesel**

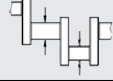
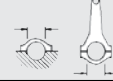

<b>8025.01</b>	2 Cyl.	17:1	1559cc	<b>FM569</b>	<b>738</b>
<b>803 A.062 (8030.01)</b>	3 Cyl.	17:1	2339cc	<b>FM570</b>	<b>739</b>
<b>804A (8040.01)</b>	4 Cyl.		3119cc	<b>FM4009</b>	<b>739</b>
<b>806 A (8060.01/.11)</b>	6 Cyl.	17:1	4678cc	<b>FM572</b>	

			
<b>87-207200-00</b> STD <b>87-207208-00</b> 0.60mm  <b>A</b> 59.60 <b>B-</b> 23.50 <b>BØ</b> 42.20 <b>D</b> 101.15  32x84	  	<b>08-207200-00</b> STD <b>08-207208-00</b> 0.60mm  2.50  CR P 2.50  P 5.50  CR P	<b>14-010620-00 D</b> <b>B</b> 99.00 <b>C</b> 187.00 <b>14-011061-00 D</b> <b>B</b> 99.10 <b>C</b> 187.00  

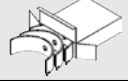
									
BE/PL	1	58.730/58.743	62.408/62.420	28.700	1.822	0.021/0.071	BS	60990CP	<b>71-4281</b> STD 0.25 0.50 0.75
MB/HL	1	76.187/76.200	80.587/80.607	25.000	2.172	0.043/0.101	BS	60076CP	<b>72-4550</b> STD 0.25 0.75
TW/A	4	85.090/85.340	101.600/101.850		3.429		AL-LF	60076AFA	<b>A192/4</b> STD .005
TW/A	4	85.090/85.340	106.550/106.800		3.429		AL-LF	60076AFF	<b>A193/4</b> STD .005

**60076AFA**

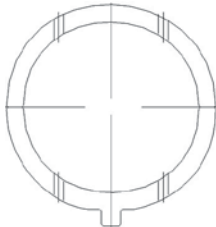

**60076AFF**

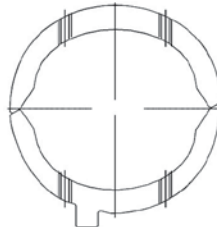

SE/PB	1	32.005/32.012	35.877/35.916	16.690			BS	60079X	<b>55-4211</b> SEMI
SE/PB	1	32.005/32.012	35.877/35.916	34.800			BS	66634YC	<b>55-4231</b> SEMI
CB/NWB 1	1	50.975/51.000	54.780/54.805	28.000	1.875		AL-LF	66231DR	<b>N153/3</b> STD
CB/NWB 2	1	49.975/50.000	53.780/53.805	24.000	1.875		AL-LF	66232DR	
CB/NWB 3	1	50.475/50.500	54.280/54.305	28.000	1.875		AL-LF	66233DR	



## 1347

 95.00

**Diesel**



8035.01      3 Cyl.      17:1      2338cc      28-35kW (38-48)PS      TD25193



BE/PL	1	58.730/58.743	62.408/62.420	28.700	1.816	0.033/0.083	BS	66630CP	<b>71-4229</b> STD 0.25 0.50 0.75 1.00
-------	---	---------------	---------------	--------	-------	-------------	----	---------	---

01/80 →

BE/PL	1	58.730/58.743	62.408/62.420	28.700	1.822	0.021/0.071	BS	60990CP	<b>71-4281</b> STD 0.25 0.75
-------	---	---------------	---------------	--------	-------	-------------	----	---------	---------------------------------

→12/79

**66630CP**

**60990CP**

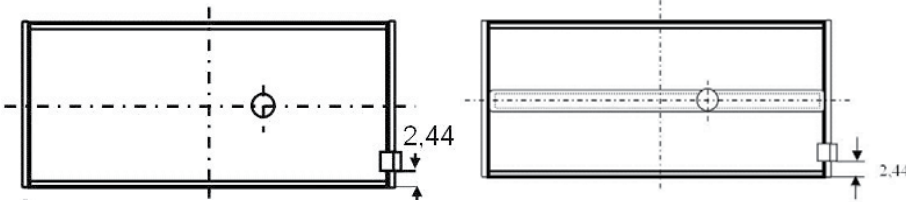

MB/HL	1	76.187/76.200	80.587/80.607	25.000	2.172	0.043/0.101	BS	66631CPA	<b>72-4547</b> STD 0.25 0.50 0.75 1.00
-------	---	---------------	---------------	--------	-------	-------------	----	----------	---

01/80 →

MB/HL	1	76.187/76.200	80.587/80.607	25.000	2.172	0.043/0.101	BS	60076CP	<b>72-4550</b> STD 0.25
-------	---	---------------	---------------	--------	-------	-------------	----	---------	----------------------------

→01/79

**66631CPA**

**60076CP**

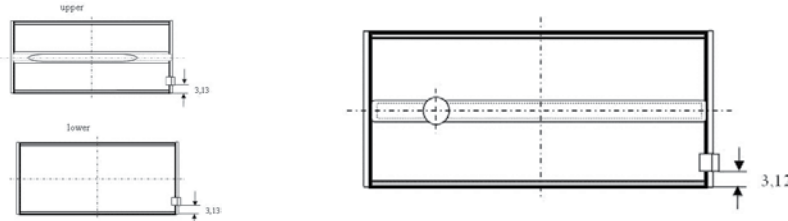

TW/A	4	85.090/85.340	101.600/101.850		3.429		AL-LF	60076AFA	<b>A192/4</b> STD .005
------	---	---------------	-----------------	--	-------	--	-------	----------	---------------------------

TW/A	4	85.090/85.340	106.550/106.800		3.429		AL-LF	60076AFF	<b>A193/4</b> STD .005
------	---	---------------	-----------------	--	-------	--	-------	----------	---------------------------

**60076AFA**

**60076AFF**



SE/PB	1	32.005/32.012	35.877/35.916	16.690			BS	60079X	<b>55-4211</b> SEMI
-------	---	---------------	---------------	--------	--	--	----	--------	------------------------

→12/77

SE/PB	1	34.005/34.012	37.846/37.884	34.800			BS	66634YA	<b>55-4230</b> SEMI
-------	---	---------------	---------------	--------	--	--	----	---------	------------------------

01/78 →

SE/PB	1	32.005/32.012	35.877/35.916	34.800			BS	66634YC	<b>55-4231</b> SEMI
-------	---	---------------	---------------	--------	--	--	----	---------	------------------------

→12/77

SE/PB	1	34.005/34.012	37.846/37.884	16.690			BS	66634Y	<b>55-4275</b> SEMI
-------	---	---------------	---------------	--------	--	--	----	--------	------------------------

# FIAT GROUP

...Continued

## 1347



95.00

Diesel

01/78 →

CB/NWB 1	1	50.975/51.000	54.780/54.805	28.000	1.875		AL-LF	66231DR	N153/3 STD
CB/NWB 2	1	49.975/50.000	53.780/53.805	24.000	1.875		AL-LF	66232DR	
CB/NWB 3	1	50.475/50.500	54.280/54.305	28.000	1.875		AL-LF	66233DR	

## 1348



95.00

Diesel



8030.00      3 Cyl.      17:1      2340cc      28-38kW (38-51)PS      TD22232      740

MB/HL	1	76.187/76.200	80.587/80.607	25.000	2.172	0.043/0.101	BS	66631CPA	72-4547 STD 0.25 0.50 0.75 1.00

01/80 →

MB/HL	1	76.187/76.200	80.587/80.607	25.000	2.172	0.043/0.101	BS	60076CP	72-4550 STD 0.25
-------	---	---------------	---------------	--------	-------	-------------	----	---------	---------------------

→12/79

66631CPA

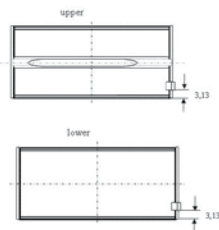

60076CP

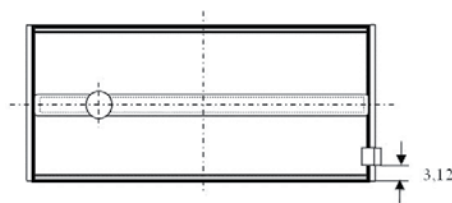

## 1349



95.00



Diesel











213 H	6 Cyl.	4678cc	FM9222
213.000	6 Cyl.	16.9:1 4678cc	FM3471
230 A.000	4 Cyl.	16.9:1 2693cc	FM2980

	08-207200-00 STD		
	08-207208-00 0.60mm		
	2.50  CR P		
	2.50  P		
	5.50  CR P		

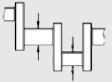
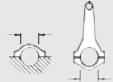

MB/HL	1	76.187/76.200	80.587/80.607	25.000	2.172	0.043/0.101	BS	66631CPA	72-4547 STD 0.25 0.50 0.75 1.00
SE/PB	1	32.005/32.012	35.877/35.916	34.800			BS	66634YC	

**1350**  **95.00** **Diesel** 

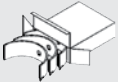

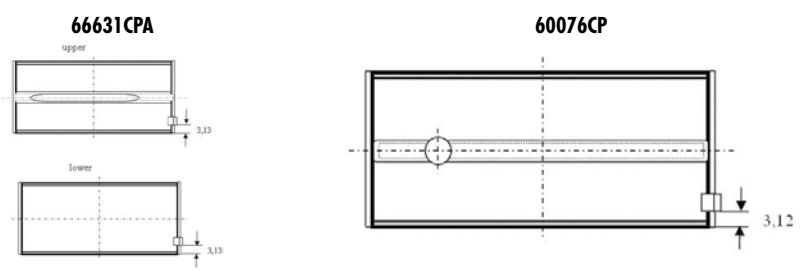



**8040.00** 4 Cyl. 17:1 3120cc **51kW (70)PS** **TD24575** **741**

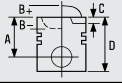

									
BE/PL	1	58.730/58.743	62.408/62.420	28.700	1.816	0.033/0.083	BS	66630CP	<b>71-4229</b> STD 0.25 0.50 0.75 1.00
MB/HL	1	76.187/76.200	80.587/80.607	25.000	2.172	0.043/0.101	BS	66631CPA	<b>72-4547</b> STD 0.25 0.50 0.75 1.00
<b>01/80→</b>									
MB/HL	1	76.187/76.200	80.587/80.607	25.000	2.172	0.043/0.101	BS	60076CP	<b>72-4550</b> STD 0.25
<b>→12/79</b>									



**1351**  **95.80** **Gas** 

**F1CE0441A EEV** 4 Cyl. 12.5:1 2998cc **100kW (136)PS** **Turbo Intercooled** **TD24071**







			
	<b>08-421600-00</b> STD		
	2.50  CK P		
	2.00  P		
	2.50  CR P		



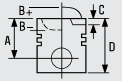





**1352**  **95.80** **Diesel** 

**F1CE0481A** 4 Cyl. 19:1 2998cc **100-114kW (136-155)PS** **Turbo Intercooled** **TD19195** **742**

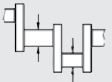
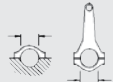
**F1CE0481B Euro 3 (D3)** 4 Cyl. 19:1 2998cc **122kW (166)PS** **Turbo Intercooled** **TD22675** **742**

**F1CE0481FA Euro 4 (D4)** 4 Cyl. 2998cc **107kW (146)PS** **Turbo Intercooled** **TD19224** **743**

			
	<b>08-421600-00</b> STD		
	2.50  CK P		
	2.00  P		
	2.50  CR P		

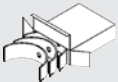
									
BE/PL	4	64.015/64.038	67.833/67.848	26.800		0.034/0.062	EC-LF	71-4082	<b>71-4082/4</b> STD 0.25 [15]

# FIAT GROUP







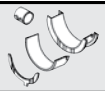

## 1353

 95.80

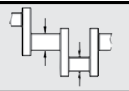
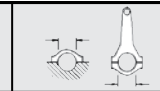
**Diesel**

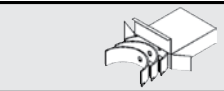

<b>F1CE0481D Euro 4 (D4)</b>	4 Cyl.	19:1	2999cc	<b>115-116kW (156-158)PS</b>	<b>Turbo Intercooled</b>	<b>TD20265</b>	<b>746</b>
<b>F1CE0481L Euro 4 (D4)</b>	4 Cyl.		2998cc	<b>107-110kW (146-150)PS</b>	<b>Turbo Intercooled</b>	<b>TD27239</b>	

									
BE/PL	4	64.015/64.038	67.833/67.848	26.800		0.034/0.062	EC-LF	71-4082	<b>71-4082/4</b> STD 0.25 [15]









## 1354

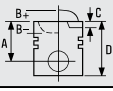
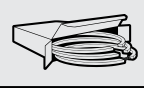





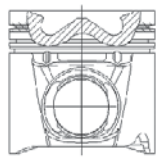

 95.80

**Diesel**

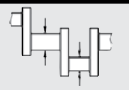
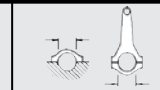

<b>F1CE0481HA EEV</b>	4 Cyl.		2998cc	<b>125-130kW (170-177)PS</b>	<b>Turbo Intercooled</b>	<b>TD19225</b>	<b>743</b>
<b>F1CE0481HC Euro 4 (D4)</b>	4 Cyl.		2998cc	<b>130kW (176)PS</b>	<b>Turbo Intercooled</b>	<b>TD19230</b>	<b>743</b>

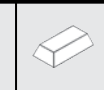
			
<b>87-421600-00</b> STD	<b>08-421600-00</b> STD		
<b>A</b> 63.00	2.50  CK P		
<b>B-</b> 16.00	2.00  P		
<b>BØ</b> 50.50	2.50  CR P		
<b>D</b> 93.50			
 36x80			
<b>AK KK RT TP</b>			
			
			

									
BE/PL	4	64.015/64.038	67.833/67.848	26.800		0.034/0.062	EC-LF	71-4082	<b>71-4082/4</b> STD 0.25 [15]

		<b>9</b>
01-4079/4	462	<b>815</b>
01-4079/4	463	<b>816</b>
01-4079/4	467	<b>828</b>
01-4079/4	467	<b>829</b>
01-4112/2	440	<b>771</b>
01-4112/2	440	<b>772</b>
01-4112/2	468	<b>831</b>
01-4112/2	469	<b>832</b>
01-4112/2	478	<b>850</b>
01-4112/2	479	<b>851</b>
01-4112/2	507	<b>904</b>
01-4112/2	508	<b>905</b>
01-4112/2	509	<b>906</b>
01-4116/4	427	<b>750</b>
01-4116/4	447	<b>785</b>
01-4116/4	447	<b>786</b>
01-4116/4	448	<b>787</b>
01-4116/4	449	<b>790</b>
01-4116/4	450	<b>791</b>
01-4116/4	451	<b>793</b>
01-4116/4	451	<b>794</b>
01-4116/4	452	<b>795</b>
01-4127/4	468	<b>830</b>
01-4127/4	484	<b>862</b>
01-4127/4	488	<b>870</b>
01-4127/4	488	<b>871</b>
01-4127/4	489	<b>872</b>
01-4127/4	490	<b>873</b>
01-4127/4	492	<b>876</b>
01-4127/4	492	<b>877</b>
01-4127/4	498	<b>887</b>
01-4127/4	499	<b>888</b>
01-4127/4	500	<b>889</b>
01-4127/4	504	<b>897</b>
01-4127/4	510	<b>909</b>
01-4127/4	511	<b>910</b>
01-4127/4	512	<b>911</b>
01-4127/4	513	<b>912</b>
01-4127/4	514	<b>913</b>
01-4127/4	514	<b>914</b>
01-4127/4	515	<b>915</b>
01-4127/4	516	<b>916</b>
01-4127/4	685	<b>1172</b>
01-4127/4	686	<b>1173</b>
01-4127/4	693	<b>1183</b>
01-4127/4	694	<b>1184</b>
01-4127/4	695	<b>1186</b>
01-4127/4	696	<b>1187</b>
01-4127/4	697	<b>1188</b>
01-4127/4	698	<b>1190</b>
01-4127/4	698	<b>1191</b>
01-4127/4	699	<b>1192</b>
01-4127/4	700	<b>1193</b>
01-4127/4	700	<b>1194</b>
01-4127/4	701	<b>1195</b>
01-4127/4	701	<b>1196</b>
01-4127/4	702	<b>1197</b>
01-4127/4	702	<b>1198</b>
01-4127/4	703	<b>1199</b>
01-4127/4	703	<b>1200</b>

		<b>9</b>
01-4127/4	704	<b>1201</b>
01-4127/4	705	<b>1202</b>
01-4127/4	705	<b>1203</b>
01-4127/4	706	<b>1204</b>
01-4127/4	707	<b>1205</b>
01-4127/4	707	<b>1206</b>
01-4127/4	708	<b>1207</b>
01-4127/4	708	<b>1208</b>
01-4127/4	709	<b>1209</b>
01-4127/4	710	<b>1210</b>
01-4127/4	710	<b>1211</b>
01-4127/4	711	<b>1212</b>
01-4127/4	711	<b>1213</b>
01-4127/4	712	<b>1214</b>
01-4127/4	713	<b>1215</b>
01-4139/4	426	<b>748</b>
01-4139/4	426	<b>749</b>
01-4139/4	427	<b>751</b>
01-4139/4	428	<b>752</b>
01-4139/4	429	<b>753</b>
01-4139/4	429	<b>754</b>
01-4139/4	430	<b>755</b>
01-4139/4	430	<b>756</b>
01-4139/4	431	<b>757</b>
01-4139/4	432	<b>758</b>
01-4139/4	432	<b>759</b>
01-4139/4	433	<b>760</b>
01-4139/4	433	<b>761</b>
01-4139/4	434	<b>762</b>
01-4139/4	435	<b>763</b>
01-4139/4	436	<b>765</b>
01-4139/4	437	<b>766</b>
01-4139/4	438	<b>767</b>
01-4139/4	438	<b>768</b>
01-4139/4	439	<b>769</b>
01-4139/4	439	<b>770</b>
01-4139/4	471	<b>839</b>
01-4149/4	687	<b>1175</b>
01-4149/4	687	<b>1176</b>
01-4149/4	688	<b>1177</b>
01-4149/4	689	<b>1178</b>
01-4149/4	690	<b>1179</b>
01-4154/4	449	<b>789</b>
01-4154/4	453	<b>797</b>
01-4154/4	453	<b>798</b>
01-4154/4	454	<b>799</b>
01-4154/4	454	<b>800</b>
01-4154/4	455	<b>801</b>
01-4154/4	455	<b>802</b>
01-4154/4	456	<b>803</b>
01-4154/4	456	<b>804</b>
01-4154/4	457	<b>805</b>
01-4154/4	458	<b>807</b>
01-4154/4	458	<b>808</b>
01-4154/4	459	<b>809</b>
01-4154/4	460	<b>810</b>
01-4154/4	460	<b>811</b>
01-4154/4	461	<b>813</b>
01-4154/4	463	<b>817</b>
01-4154/4	464	<b>818</b>

		<b>9</b>
01-4154/4	464	<b>819</b>
01-4154/4	465	<b>821</b>
01-4154/4	466	<b>825</b>
01-4155/4	585	<b>1021</b>
01-4155/4	675	<b>1155</b>
01-4155/4	676	<b>1156</b>
01-4155/4	676	<b>1157</b>
01-4160/4	518	<b>923</b>
01-4160/4	519	<b>924</b>
01-4163/4	471	<b>837</b>
01-4171/4	468	<b>830</b>
01-4171/4	488	<b>870</b>
01-4171/4	488	<b>871</b>
01-4171/4	489	<b>872</b>
01-4171/4	490	<b>873</b>
01-4171/4	492	<b>876</b>
01-4171/4	498	<b>887</b>
01-4171/4	499	<b>888</b>
01-4171/4	500	<b>889</b>
01-4171/4	685	<b>1172</b>
01-4171/4	686	<b>1173</b>
01-4171/4	693	<b>1183</b>
01-4171/4	694	<b>1184</b>
01-4171/4	695	<b>1186</b>
01-4171/4	696	<b>1187</b>
01-4171/4	697	<b>1188</b>
01-4175/4	501	<b>891</b>
01-4175/4	501	<b>892</b>
01-4175/4	502	<b>894</b>
01-4175/4	502	<b>895</b>
01-4175/4	503	<b>896</b>
01-4175/4	561	<b>993</b>
01-4175/4	563	<b>994</b>
01-4175/4	564	<b>995</b>
01-4175/4	569	<b>1001</b>
01-4175/4	575	<b>1008</b>
01-4175/4	583	<b>1016</b>
01-4175/4	583	<b>1017</b>
01-4175/4	584	<b>1018</b>
01-4175/4	605	<b>1055</b>
01-4175/4	619	<b>1075</b>
01-4175/4	619	<b>1076</b>
01-4175/4	620	<b>1077</b>
01-4175/4	621	<b>1078</b>
01-4175/4	621	<b>1079</b>
01-4175/4	623	<b>1082</b>
01-4175/4	639	<b>1109</b>
01-4175/4	640	<b>1110</b>
01-4175/4	641	<b>1111</b>
01-4175/4	641	<b>1112</b>
01-4175/4	642	<b>1113</b>
01-4175/4	652	<b>1127</b>
01-4175/4	671	<b>1148</b>
01-4176/4	473	<b>842</b>
01-4176/4	473	<b>843</b>
01-4176/4	479	<b>852</b>
01-4176/4	500	<b>890</b>
01-4176/4	606	<b>1056</b>
01-4176/4	606	<b>1057</b>
01-4176/4	607	<b>1058</b>

		<b>9</b>
01-4176/4	608	<b>1059</b>
01-4176/4	608	<b>1060</b>
01-4176/4	609	<b>1061</b>
01-4176/4	610	<b>1062</b>
01-4176/4	610	<b>1063</b>
01-4176/4	611	<b>1064</b>
01-4176/4	612	<b>1065</b>
01-4176/4	613	<b>1066</b>
01-4176/4	614	<b>1067</b>
01-4176/4	615	<b>1068</b>
01-4176/4	616	<b>1069</b>
01-4176/4	616	<b>1070</b>
01-4176/4	617	<b>1071</b>
01-4176/4	617	<b>1072</b>
01-4176/4	617	<b>1073</b>
01-4178/4	493	<b>878</b>
01-4178/4	494	<b>879</b>
01-4178/4	494	<b>880</b>
01-4178/4	495	<b>881</b>
01-4178/4	495	<b>882</b>
01-4178/4	496	<b>883</b>
01-4178/4	496	<b>884</b>
01-4178/4	497	<b>885</b>
01-4178/4	601	<b>1048</b>
01-4178/4	601	<b>1049</b>
01-4178/4	603	<b>1051</b>
01-4178/4	603	<b>1052</b>
01-4178/4	604	<b>1053</b>
01-4178/4	604	<b>1054</b>
01-4178/4	713	<b>1216</b>
01-4178/4	714	<b>1217</b>
01-4178/4	715	<b>1218</b>
01-4178/4	716	<b>1219</b>
01-4178/4	716	<b>1220</b>
01-4181/4	765	<b>1273</b>
01-4181/4	827	<b>1321</b>
01-4188/4	493	<b>878</b>
01-4188/4	494	<b>879</b>
01-4188/4	495	<b>882</b>
01-4188/4	496	<b>883</b>
01-4188/4	497	<b>885</b>
01-4188/4	601	<b>1049</b>
01-4188/4	603	<b>1051</b>
01-4188/4	603	<b>1052</b>
01-4188/4	604	<b>1053</b>
01-4188/4	604	<b>1054</b>
01-4188/4	713	<b>1216</b>
01-4188/4	714	<b>1217</b>
01-4188/4	715	<b>1218</b>
01-4188/4	716	<b>1219</b>
01-4188/4	716	<b>1220</b>
01-4200/4	436	<b>764</b>
01-4200/4	560	<b>991</b>
01-4200/4	561	<b>992</b>
01-4200/4	587	<b>1024</b>
01-4200/4	588	<b>1025</b>
01-4200/4	590	<b>1028</b>
01-4200/4	591	<b>1029</b>
01-4207/4	472	<b>840</b>
01-4207/4	473	<b>841</b>

# NUMERICAL PARTS LIST

Numerische Teilenummernliste • Elenco riferimenti  
Liste des références produits

		9	
01-4207/4	474	<b>844</b>	
01-4207/4	475	<b>845</b>	
01-4207/4	476	<b>846</b>	
01-4207/4	477	<b>847</b>	
01-4207/4	477	<b>848</b>	
01-4207/4	477	<b>849</b>	
01-4207/4	491	<b>874</b>	
01-4207/4	491	<b>875</b>	
01-4207/4	695	<b>1185</b>	
01-4207/4	698	<b>1189</b>	
01-4298/4	687	<b>1175</b>	
01-4298/4	687	<b>1176</b>	
01-4298/4	688	<b>1177</b>	
01-4298/4	689	<b>1178</b>	
01-4298/4	690	<b>1179</b>	
01-4307/4	469	<b>833</b>	
01-4307/4	470	<b>834</b>	
01-4307/4	470	<b>835</b>	
01-4307/4	498	<b>886</b>	
01-4314/4	485	<b>863</b>	
01-4558/4	629	<b>1094</b>	
01-4558/4	630	<b>1095</b>	
01-4558/4	718	<b>1224</b>	
01-4558/4	719	<b>1225</b>	
01-4947/4	483	<b>858</b>	
08-104000-00	561	<b>992</b>	
08-104008-00	561	<b>992</b>	
08-105500-00	585	<b>1022</b>	
08-105500-00	586	<b>1023</b>	
08-105500-00	589	<b>1026</b>	
08-105507-00	585	<b>1022</b>	
08-105507-00	586	<b>1023</b>	
08-105507-00	589	<b>1026</b>	
08-105510-00	585	<b>1022</b>	
08-105510-00	586	<b>1023</b>	
08-105510-00	589	<b>1026</b>	
08-107100-00	631	<b>1096</b>	
08-107100-00	635	<b>1102</b>	
08-107100-00	635	<b>1103</b>	
08-107100-00	639	<b>1108</b>	
08-107100-10	631	<b>1096</b>	
08-107100-10	635	<b>1102</b>	
08-107100-10	635	<b>1103</b>	
08-107100-10	639	<b>1108</b>	
08-107800-10	493	<b>878</b>	
08-107800-10	494	<b>879</b>	
08-107800-10	494	<b>880</b>	
08-107800-10	495	<b>881</b>	
08-107800-10	497	<b>885</b>	
08-107900-00	530	<b>941</b>	
08-107900-00	531	<b>943</b>	
08-107900-00	536	<b>951</b>	
08-107900-00	538	<b>954</b>	
08-107900-00	543	<b>964</b>	
08-107900-00	551	<b>976</b>	
08-107900-00	559	<b>990</b>	
08-107908-00	530	<b>941</b>	
08-107908-00	531	<b>943</b>	
08-107908-00	536	<b>951</b>	
08-107908-00	538	<b>954</b>	

		9	
08-107908-00	543	<b>964</b>	
08-107908-00	551	<b>976</b>	
08-107908-00	559	<b>990</b>	
08-108000-00	527	<b>937</b>	
08-108000-00	549	<b>973</b>	
08-108000-00	550	<b>975</b>	
08-108008-00	527	<b>937</b>	
08-108008-00	549	<b>973</b>	
08-108008-00	550	<b>975</b>	
08-108200-00	843	<b>1343</b>	
08-108200-00	845	<b>1345</b>	
08-108208-00	843	<b>1343</b>	
08-108208-00	845	<b>1345</b>	
08-109000-10	601	<b>1048</b>	
08-109000-10	601	<b>1049</b>	
08-109000-10	602	<b>1050</b>	
08-109000-10	603	<b>1052</b>	
08-109008-10	601	<b>1048</b>	
08-109008-10	602	<b>1050</b>	
08-109008-10	603	<b>1052</b>	
08-110000-00	721	<b>1228</b>	
08-110100-00	729	<b>1245</b>	
08-110100-00	729	<b>1246</b>	
08-110100-00	730	<b>1248</b>	
08-110200-00	618	<b>1074</b>	
08-110200-00	629	<b>1093</b>	
08-110200-00	634	<b>1101</b>	
08-110200-00	636	<b>1105</b>	
08-110200-00	637	<b>1106</b>	
08-110200-00	671	<b>1149</b>	
08-110200-00	673	<b>1151</b>	
08-110300-00	713	<b>1216</b>	
08-110300-00	714	<b>1217</b>	
08-110300-00	716	<b>1219</b>	
08-110300-00	717	<b>1221</b>	
08-110500-00	725	<b>1237</b>	
08-110500-00	726	<b>1238</b>	
08-110500-00	726	<b>1239</b>	
08-110500-00	727	<b>1240</b>	
08-110500-00	728	<b>1243</b>	
08-110900-00	596	<b>1038</b>	
08-110900-00	599	<b>1042</b>	
08-110906-00	596	<b>1038</b>	
08-110906-00	599	<b>1042</b>	
08-114700-00	674	<b>1154</b>	
08-114700-00	677	<b>1160</b>	
08-114700-00	678	<b>1161</b>	
08-114700-00	678	<b>1162</b>	
08-114700-00	679	<b>1163</b>	
08-114700-00	680	<b>1164</b>	
08-114700-00	680	<b>1165</b>	
08-114700-00	683	<b>1169</b>	
08-114700-00	684	<b>1170</b>	
08-114700-00	685	<b>1171</b>	
08-114708-00	674	<b>1154</b>	
08-114708-00	677	<b>1160</b>	
08-114708-00	678	<b>1161</b>	
08-114708-00	678	<b>1162</b>	
08-114708-00	679	<b>1163</b>	

		9	
08-114708-00	680	<b>1164</b>	
08-114708-00	680	<b>1165</b>	
08-114708-00	683	<b>1169</b>	
08-114708-00	684	<b>1170</b>	
08-114708-00	685	<b>1171</b>	
08-118000-00	520	<b>926</b>	
08-118000-00	521	<b>927</b>	
08-118000-00	522	<b>928</b>	
08-118000-00	523	<b>929</b>	
08-118000-00	523	<b>930</b>	
08-118000-00	525	<b>933</b>	
08-118000-00	547	<b>970</b>	
08-118006-00	520	<b>926</b>	
08-118006-00	521	<b>927</b>	
08-118006-00	522	<b>928</b>	
08-118006-00	523	<b>929</b>	
08-118006-00	525	<b>933</b>	
08-118006-00	547	<b>970</b>	
08-118008-00	520	<b>926</b>	
08-118008-00	521	<b>927</b>	
08-118008-00	522	<b>928</b>	
08-118008-00	523	<b>929</b>	
08-118008-00	525	<b>933</b>	
08-118008-00	547	<b>970</b>	
08-122200-00	832	<b>1329</b>	
08-122200-00	833	<b>1331</b>	
08-122200-00	835	<b>1333</b>	
08-122200-00	836	<b>1334</b>	
08-122200-00	837	<b>1335</b>	
08-122200-00	838	<b>1336</b>	
08-122200-00	839	<b>1338</b>	
08-122200-00	840	<b>1339</b>	
08-122200-00	841	<b>1340</b>	
08-122200-00	842	<b>1342</b>	
08-122200-00	844	<b>1344</b>	
08-122208-00	832	<b>1329</b>	
08-122208-00	833	<b>1331</b>	
08-122208-00	835	<b>1333</b>	
08-122208-00	836	<b>1334</b>	
08-122208-00	837	<b>1335</b>	
08-122208-00	838	<b>1336</b>	
08-122208-00	839	<b>1338</b>	
08-122208-00	840	<b>1339</b>	
08-122208-00	841	<b>1340</b>	
08-122208-00	842	<b>1342</b>	
08-122208-00	844	<b>1344</b>	
08-124000-00	529	<b>939</b>	
08-124000-00	530	<b>941</b>	
08-124000-00	531	<b>942</b>	
08-124000-00	531	<b>943</b>	
08-124000-00	532	<b>944</b>	
08-124000-00	533	<b>945</b>	
08-124000-00	534	<b>947</b>	
08-124000-00	536	<b>950</b>	
08-124000-00	536	<b>951</b>	
08-124000-00	538	<b>953</b>	
08-124000-00	538	<b>954</b>	
08-124000-00	539	<b>955</b>	

		9	
08-124000-00	541	<b>957</b>	
08-124000-00	543	<b>964</b>	
08-124000-00	551	<b>976</b>	
08-124000-00	552	<b>977</b>	
08-124000-00	555	<b>982</b>	
08-124000-00	556	<b>983</b>	
08-124000-00	559	<b>990</b>	
08-124006-00	529	<b>939</b>	
08-124006-00	530	<b>941</b>	
08-124006-00	531	<b>942</b>	
08-124006-00	531	<b>943</b>	
08-124006-00	532	<b>944</b>	
08-124006-00	532	<b>944</b>	
08-124006-00	533	<b>945</b>	
08-124006-00	534	<b>947</b>	
08-124006-00	536	<b>950</b>	
08-124006-00	536	<b>951</b>	
08-124006-00	538	<b>953</b>	
08-124006-00	538	<b>954</b>	
08-124006-00	539	<b>955</b>	
08-124006-00	541	<b>957</b>	
08-124006-00	543	<b>964</b>	
08-124006-00	543	<b>964</b>	
08-124008-00	532	<b>944</b>	
08-124008-00	533	<b>945</b>	
08-124008-00	534	<b>947</b>	
08-124008-00	536	<b>950</b>	
08-124008-00	536	<b>951</b>	
08-124008-00	538	<b>953</b>	
08-124008-00	538	<b>954</b>	
08-124008-00	539	<b>955</b>	
08-124008-00	541	<b>957</b>	
08-124008-00	543	<b>964</b>	
08-124008-00	551	<b>976</b>	
08-124008-00	552	<b>977</b>	
08-124008-00	555	<b>982</b>	
08-124008-00	556	<b>983</b>	
08-124008-00	559	<b>990</b>	
08-124600-00	728	<b>1242</b>	
08-124700-00	598	<b>1040</b>	
08-124706-00	598	<b>1040</b>	
08-124708-00	598	<b>1040</b>	
08-124800-00	516	<b>916</b>	
08-124806-00	516	<b>916</b>	
08-124808-00	516	<b>916</b>	
08-126600-00	681	<b>1166</b>	
08-126600-00	682	<b>1167</b>	
08-126608-00	681	<b>1166</b>	
08-126608-00	682	<b>1167</b>	
08-137600-00	441	<b>773</b>	
08-137600-00	442	<b>776</b>	
08-137600-00	443	<b>777</b>	
08-137606-00	441	<b>773</b>	



# NUMERICAL PARTS LIST

Numerische Teilenummernliste • Elenco riferimenti  
Liste des références produits

			9
08-203108-00	501	891	
08-203108-00	502	893	
08-203108-00	502	895	
08-203108-00	503	896	
08-203108-00	504	897	
08-203108-00	507	904	
08-203108-00	508	905	
08-203108-00	509	906	
08-203110-00	488	871	
08-203110-00	489	872	
08-203110-00	498	887	
08-203110-00	499	888	
08-203110-00	500	889	
08-203110-00	501	891	
08-203110-00	502	893	
08-203110-00	502	895	
08-203110-00	503	896	
08-203110-00	504	897	
08-203110-00	507	904	
08-203110-00	508	905	
08-203110-00	509	906	
08-203111-00	488	871	
08-203111-00	489	872	
08-203111-00	498	887	
08-203111-00	499	888	
08-203111-00	500	889	
08-203111-00	501	891	
08-203111-00	502	893	
08-203111-00	502	895	
08-203111-00	503	896	
08-203111-00	504	897	
08-203111-00	507	904	
08-203111-00	508	905	
08-203111-00	509	906	
08-207200-00	846	1346	
08-207200-00	848	1349	
08-207208-00	846	1346	
08-207208-00	848	1349	
08-207600-00	605	1055	
08-207600-00	606	1056	
08-207600-00	607	1058	
08-207600-00	608	1059	
08-207600-00	608	1060	
08-207600-00	610	1062	
08-207600-00	610	1063	
08-207600-00	611	1064	
08-207600-00	612	1065	
08-207600-00	613	1066	
08-207600-00	614	1067	
08-207600-00	615	1068	
08-207600-00	619	1076	
08-207600-00	621	1079	
08-207600-00	639	1109	
08-207600-00	640	1110	
08-207600-00	641	1112	
08-207600-00	642	1113	
08-207600-00	643	1114	
08-207600-00	644	1115	
08-207600-00	646	1117	
08-207600-00	655	1130	
08-207600-00	657	1132	
08-207600-00	658	1133	
08-207600-00	659	1134	
08-207600-00	660	1135	
08-207600-00	661	1136	
08-207600-00	662	1137	
08-207600-00	663	1138	
08-207600-00	664	1139	
08-207600-00	665	1140	
08-207600-00	667	1142	
08-207600-00	668	1143	
08-207600-00	669	1144	
08-207600-00	670	1145	
08-207600-00	671	1146	
08-207600-00	672	1147	
08-207600-00	673	1148	
08-207600-00	674	1149	
08-207600-00	675	1150	
08-207600-00	676	1151	
08-207600-00	677	1152	
08-207600-00	678	1153	
08-207600-00	679	1154	
08-207600-00	680	1155	
08-207600-00	681	1156	
08-207600-00	682	1157	
08-207600-00	683	1158	
08-207600-00	684	1159	
08-207600-00	685	1160	
08-207600-00	686	1161	
08-207600-00	687	1162	
08-207600-00	688	1163	
08-207600-00	689	1164	
08-207600-00	690	1165	
08-207600-00	691	1166	
08-207600-00	692	1167	
08-207600-00	693	1168	
08-207600-00	694	1169	
08-207600-00	695	1170	
08-207600-00	696	1171	
08-207600-00	697	1172	
08-207600-00	698	1173	
08-207600-00	699	1174	
08-207600-00	700	1175	
08-207600-00	701	1176	
08-207600-00	702	1177	
08-207600-00	703	1178	
08-207600-00	704	1179	
08-207600-00	705	1180	
08-207600-00	706	1181	
08-207600-00	707	1182	
08-207600-00	708	1183	
08-207600-00	709	1184	
08-207600-00	710	1185	
08-207600-00	711	1186	
08-207600-00	712	1187	
08-207600-00	713	1188	
08-207600-00	714	1189	
08-207600-00	715	1190	
08-207600-00	716	1191	
08-207600-00	717	1192	
08-207600-00	718	1193	
08-207600-00	719	1194	
08-207600-00	720	1195	
08-207600-00	721	1196	
08-207600-00	722	1197	
08-207600-00	723	1198	
08-207600-00	724	1199	
08-207600-00	725	1200	
08-207600-00	726	1201	
08-207600-00	727	1202	
08-207600-00	728	1203	
08-207600-00	729	1204	
08-207600-00	730	1205	
08-207600-00	731	1206	
08-207600-00	732	1207	
08-207600-00	733	1208	
08-207600-00	734	1209	
08-207600-00	735	1210	
08-207600-00	736	1211	
08-207600-00	737	1212	
08-207600-00	738	1213	
08-207600-00	739	1214	
08-207600-00	740	1215	
08-207600-00	741	1216	
08-207600-00	742	1217	
08-207600-00	743	1218	
08-207600-00	744	1219	
08-207600-00	745	1220	
08-207600-00	746	1221	
08-207600-00	747	1222	
08-207600-00	748	1223	
08-207600-00	749	1224	
08-207600-00	750	1225	
08-207600-00	751	1226	
08-207600-00	752	1227	
08-207600-00	753	1228	
08-207600-00	754	1229	
08-207600-00	755	1230	
08-207600-00	756	1231	
08-207600-00	757	1232	
08-207600-00	758	1233	
08-207600-00	759	1234	
08-207600-00	760	1235	
08-207600-00	761	1236	
08-207600-00	762	1237	
08-207600-00	763	1238	
08-207600-00	764	1239	
08-207600-00	765	1240	
08-207600-00	766	1241	
08-207600-00	767	1242	
08-207600-00	768	1243	
08-207600-00	769	1244	
08-207600-00	770	1245	
08-207600-00	771	1246	
08-207600-00	772	1247	
08-207600-00	773	1248	
08-207600-00	774	1249	
08-207600-00	775	1250	
08-207600-00	776	1251	
08-207600-00	777	1252	
08-207600-00	778	1253	
08-207600-00	779	1254	
08-207600-00	780	1255	
08-207600-00	781	1256	
08-207600-00	782	1257	
08-207600-00	783	1258	
08-207600-00	784	1259	
08-207600-00	785	1260	
08-207600-00	786	1261	
08-207600-00	787	1262	
08-207600-00	788	1263	
08-207600-00	789	1264	
08-207600-00	790	1265	
08-207600-00	791	1266	
08-207600-00	792	1267	
08-207600-00	793	1268	
08-207600-00	794	1269	
08-207600-00	795	1270	
08-207600-00	796	1271	
08-207600-00	797	1272	
08-207600-00	798	1273	
08-207600-00	799	1274	
08-207600-00	800	1275	

			9
08-207600-00	649	1122	
08-207600-00	650	1123	
08-207600-00	652	1127	
08-207600-00	653	1128	
08-207600-00	654	1129	
08-207600-00	655	1130	
08-207600-00	657	1132	
08-207600-00	658	1133	
08-207600-00	659	1134	
08-207600-00	660	1135	
08-207600-00	661	1136	
08-207600-00	662	1137	
08-207600-00	663	1138	
08-207600-00	664	1139	
08-207600-00	665	1140	
08-207600-00	667	1142	
08-207600-00	668	1143	
08-207604-00	605	1055	
08-207604-00	606	1056	
08-207604-00	607	1058	
08-207604-00	608	1059	
08-207604-00	608	1060	
08-207604-00	610	1062	
08-207604-00	610	1063	
08-207604-00	611	1064	
08-207604-00	612	1065	
08-207604-00	613	1066	
08-207604-00	614	1067	
08-207604-00	615	1068	
08-207604-00	619	1076	
08-207604-00	621	1079	
08-207604-00	639	1109	
08-207604-00	640	1110	
08-207604-00	641	1112	
08-207604-00	642	1113	
08-207604-00	643	1114	
08-207604-00	644	1115	
08-207604-00	646	1117	
08-207604-00	649	1122	
08-207604-00	650	1123	
08-207604-00	652	1127	
08-207604-00	653	1128	
08-207604-00	654	1129	
08-207604-00	655	1130	
08-207604-00	657	1132	
08-207604-00	658	1133	
08-207604-00	659	1134	
08-207604-00	660	1135	
08-207604-00	661	1136	
08-207604-00	662	1137	
08-207604-00	663	1138	
08-207604-00	664	1139	
08-207604-00	665	1140	
08-207604-00	667	1142	
08-207604-00	668	1143	
08-207606-00	605	1055	
08-207606-00	606	1056	
08-207606-00	607	1058	
08-207606-00	608	1059	
08-207606-00	608	1060	
08-207606-00	610	1062	
08-207606-00	610	1063	
08-207606-00	611	1064	
08-207606-00	612	1065	
08-207606-00	613	1066	
08-207606-00	614	1067	
08-207606-00	615	1068	
08-207606-00	619	1076	
08-207606-00	621	1079	
08-207606-00	639	1109	
08-207606-00	640	1110	
08-207606-00	641	1112	
08-207606-00	642	1113	
08-207606-00	643	1114	
08-207606-00	644	1115	
08-207606-00	646	1117	
08-207606-00	649	1122	
08-207606-00	650	1123	
08-207606-00	652	1127	



		 <b>9</b>	
08-209806-00	433	<b>760</b>	
08-209806-00	433	<b>761</b>	
08-209806-00	434	<b>762</b>	
08-209806-00	436	<b>765</b>	
08-209806-00	437	<b>766</b>	
08-209806-00	471	<b>839</b>	
08-209808-00	426	<b>749</b>	
08-209808-00	427	<b>751</b>	
08-209808-00	428	<b>752</b>	
08-209808-00	429	<b>753</b>	
08-209808-00	429	<b>754</b>	
08-209808-00	430	<b>755</b>	
08-209808-00	431	<b>757</b>	
08-209808-00	432	<b>758</b>	
08-209808-00	433	<b>760</b>	
08-209808-00	433	<b>761</b>	
08-209808-00	434	<b>762</b>	
08-209808-00	436	<b>765</b>	
08-209808-00	437	<b>766</b>	
08-209808-00	471	<b>839</b>	
08-214400-10	731	<b>1250</b>	
08-214400-10	743	<b>1260</b>	
08-214400-10	747	<b>1262</b>	
08-214400-10	749	<b>1263</b>	
08-214400-10	751	<b>1264</b>	
08-214400-10	757	<b>1268</b>	
08-214400-10	759	<b>1269</b>	
08-214400-10	760	<b>1270</b>	
08-214500-10	731	<b>1250</b>	
08-214500-10	743	<b>1260</b>	
08-214500-10	745	<b>1261</b>	
08-214500-10	747	<b>1262</b>	
08-214500-10	749	<b>1263</b>	
08-214500-10	751	<b>1264</b>	
08-214500-10	757	<b>1267</b>	
08-214500-10	757	<b>1268</b>	
08-214500-10	759	<b>1269</b>	
08-214500-10	760	<b>1270</b>	
08-214508-10	731	<b>1250</b>	
08-214508-10	743	<b>1260</b>	
08-214508-10	745	<b>1261</b>	
08-214508-10	747	<b>1262</b>	
08-214508-10	749	<b>1263</b>	
08-214508-10	751	<b>1264</b>	
08-214508-10	757	<b>1267</b>	
08-214508-10	757	<b>1268</b>	
08-214508-10	759	<b>1269</b>	
08-214508-10	760	<b>1270</b>	
08-215100-10	584	<b>1018</b>	
08-215108-10	584	<b>1018</b>	
08-215110-10	584	<b>1018</b>	
08-215200-10	475	<b>845</b>	
08-215200-10	476	<b>846</b>	
08-215206-10	475	<b>845</b>	
08-215206-10	476	<b>846</b>	
08-215208-10	475	<b>845</b>	
08-215208-10	476	<b>846</b>	
08-215211-10	475	<b>845</b>	
08-215211-10	476	<b>846</b>	
08-215300-10	607	<b>1058</b>	



		 <b>9</b>	
08-215300-10	610	<b>1062</b>	
08-215300-10	611	<b>1064</b>	
08-215300-10	613	<b>1066</b>	
08-215300-10	614	<b>1067</b>	
08-215300-10	615	<b>1068</b>	
08-215300-10	619	<b>1076</b>	
08-215300-10	621	<b>1079</b>	
08-215300-10	642	<b>1113</b>	
08-215300-10	643	<b>1114</b>	
08-215300-10	644	<b>1115</b>	
08-215300-10	646	<b>1117</b>	
08-215300-10	652	<b>1127</b>	
08-215300-10	653	<b>1128</b>	
08-215300-10	654	<b>1129</b>	
08-215300-10	655	<b>1130</b>	
08-215300-10	657	<b>1132</b>	
08-215300-10	658	<b>1133</b>	
08-215300-10	659	<b>1134</b>	
08-215300-10	660	<b>1135</b>	
08-215300-10	661	<b>1136</b>	
08-215300-10	662	<b>1137</b>	
08-215300-10	663	<b>1138</b>	
08-215300-10	664	<b>1139</b>	
08-215300-10	665	<b>1140</b>	
08-215300-10	667	<b>1142</b>	
08-215300-10	668	<b>1143</b>	
08-215300-10	672	<b>1150</b>	
08-215306-10	607	<b>1058</b>	
08-215306-10	610	<b>1062</b>	
08-215306-10	611	<b>1064</b>	
08-215306-10	613	<b>1066</b>	
08-215306-10	614	<b>1067</b>	
08-215306-10	615	<b>1068</b>	
08-215306-10	619	<b>1076</b>	
08-215306-10	621	<b>1079</b>	
08-215306-10	642	<b>1113</b>	
08-215306-10	643	<b>1114</b>	
08-215306-10	644	<b>1115</b>	
08-215306-10	647	<b>1119</b>	
08-215306-10	652	<b>1127</b>	
08-215306-10	653	<b>1128</b>	
08-215306-10	654	<b>1129</b>	
08-215306-10	655	<b>1130</b>	
08-215306-10	657	<b>1132</b>	
08-215306-10	658	<b>1133</b>	
08-215306-10	659	<b>1134</b>	
08-215306-10	660	<b>1135</b>	
08-215306-10	661	<b>1136</b>	
08-215306-10	662	<b>1137</b>	
08-215306-10	663	<b>1138</b>	
08-215306-10	664	<b>1139</b>	
08-215306-10	665	<b>1140</b>	
08-215306-10	667	<b>1142</b>	
08-215306-10	668	<b>1143</b>	
08-215306-10	672	<b>1150</b>	
08-215308-10	607	<b>1058</b>	
08-215308-10	610	<b>1062</b>	
08-215308-10	611	<b>1064</b>	



		 <b>9</b>	
08-215308-10	613	<b>1066</b>	
08-215308-10	614	<b>1067</b>	
08-215308-10	615	<b>1068</b>	
08-215308-10	619	<b>1076</b>	
08-215308-10	621	<b>1079</b>	
08-215308-10	642	<b>1113</b>	
08-215308-10	643	<b>1114</b>	
08-215308-10	644	<b>1115</b>	
08-215308-10	646	<b>1117</b>	
08-215308-10	647	<b>1119</b>	
08-215308-10	652	<b>1127</b>	
08-215308-10	653	<b>1128</b>	
08-215308-10	654	<b>1129</b>	
08-215308-10	655	<b>1130</b>	
08-215308-10	657	<b>1132</b>	
08-215308-10	658	<b>1133</b>	
08-215308-10	659	<b>1134</b>	
08-215308-10	660	<b>1135</b>	
08-215308-10	661	<b>1136</b>	
08-215308-10	662	<b>1137</b>	
08-215308-10	663	<b>1138</b>	
08-215308-10	664	<b>1139</b>	
08-215308-10	665	<b>1140</b>	
08-215308-10	667	<b>1142</b>	
08-215308-10	668	<b>1143</b>	
08-215308-10	672	<b>1150</b>	
08-245200-00	733	<b>1251</b>	
08-245200-00	733	<b>1252</b>	
08-245200-00	735	<b>1253</b>	
08-245200-00	738	<b>1255</b>	
08-245200-00	740	<b>1256</b>	
08-245200-00	753	<b>1265</b>	
08-245200-00	755	<b>1266</b>	
08-245200-00	762	<b>1271</b>	
08-245200-00	764	<b>1272</b>	
08-245200-00	774	<b>1281</b>	
08-245200-00	776	<b>1282</b>	
08-245200-00	778	<b>1283</b>	
08-245200-00	779	<b>1284</b>	
08-245200-00	780	<b>1285</b>	
08-245200-00	781	<b>1286</b>	
08-245200-00	783	<b>1288</b>	
08-245200-00	785	<b>1289</b>	
08-245200-00	803	<b>1303</b>	
08-245200-00	804	<b>1304</b>	
08-245200-00	807	<b>1307</b>	
08-245200-00	809	<b>1308</b>	
08-245200-00	811	<b>1309</b>	
08-245200-00	814	<b>1311</b>	
08-245200-00	816	<b>1312</b>	
08-245200-00	824	<b>1319</b>	
08-245200-00	826	<b>1320</b>	
08-245200-00	827	<b>1321</b>	
08-245200-00	826	<b>1320</b>	
08-245208-00	733	<b>1251</b>	
08-245208-00	733	<b>1252</b>	
08-245208-00	735	<b>1253</b>	
08-245208-00	738	<b>1255</b>	
08-245208-00	740	<b>1256</b>	
08-245208-00	753	<b>1265</b>	
08-245208-00	755	<b>1266</b>	
08-245208-00	762	<b>1271</b>	



		 <b>9</b>	
08-245208-00	764	<b>1272</b>	
08-245208-00	774	<b>1281</b>	
08-245208-00	776	<b>1282</b>	
08-245208-00	778	<b>1283</b>	
08-245208-00	779	<b>1284</b>	
08-245208-00	780	<b>1285</b>	
08-245208-00	781	<b>1286</b>	
08-245208-00	783	<b>1288</b>	
08-245208-00	785	<b>1289</b>	
08-245208-00	803	<b>1303</b>	
08-245208-00	804	<b>1304</b>	
08-245208-00	807	<b>1307</b>	
08-245208-00	809	<b>1308</b>	
08-245208-00	811	<b>1309</b>	
08-245208-00	814	<b>1311</b>	
08-245208-00	816	<b>1312</b>	
08-245208-00	824	<b>1319</b>	
08-245208-00	826	<b>1320</b>	
08-269700-00	472	<b>840</b>	
08-269700-00	473	<b>843</b>	
08-269700-00	474	<b>844</b>	
08-269704-00	472	<b>840</b>	
08-269704-00	473	<b>843</b>	
08-269704-00	474	<b>844</b>	
08-269706-00	472	<b>840</b>	
08-269706-00	473	<b>843</b>	
08-269706-00	474	<b>844</b>	
08-269710-00	472	<b>840</b>	
08-269710-00	473	<b>843</b>	
08-269710-00	474	<b>844</b>	
08-313400-00	485	<b>863</b>	
08-315200-00	485	<b>863</b>	
08-316900-00	718	<b>1224</b>	
08-316900-00	719	<b>1225</b>	
08-316907-00	718	<b>1224</b>	
08-316907-00	719	<b>1225</b>	
08-323400-00	585	<b>1021</b>	
08-325500-00	585	<b>1022</b>	
08-325500-00	586	<b>1023</b>	
08-325500-00	589	<b>1026</b>	
08-325507-00	585	<b>1022</b>	
08-325507-00	586	<b>1023</b>	
08-325507-00	589	<b>1026</b>	
08-421600-00	849	<b>1351</b>	
08-421600-00	849	<b>1352</b>	
08-421600-00	850	<b>1354</b>	
08-424000-00	471	<b>838</b>	
08-424007-00	471	<b>838</b>	
08-424008-00	471	<b>838</b>	
08-425000-00	765	<b>1274</b>	
08-425000-00	766	<b>1275</b>	
08-425000-00	767	<b>1276</b>	
08-425000-00	772	<b>1279</b>	
08-425000-00	773	<b>1280</b>	
08-425000-00	800	<b>1300</b>	
08-425000-00	801	<b>1301</b>	
08-425000-00	802	<b>1302</b>	
08-425000-00	812	<b>1310</b>	
08-425000-00	819	<b>1314</b>	
08-425000-00	821	<b>1316</b>	



# NUMERICAL PARTS LIST

Numerische Teilenummernliste • Elenco riferimenti  
Liste des références produits

			
08-425008-00	765	1274	
08-425008-00	766	1275	
08-425008-00	767	1276	
08-425008-00	772	1279	
08-425008-00	773	1280	
08-425008-00	800	1300	
08-425008-00	801	1301	
08-425008-00	802	1302	
08-425008-00	812	1310	
08-425008-00	819	1314	
08-425008-00	821	1316	
08-425600-00	443	778	
08-425606-00	443	778	
08-425608-00	443	778	
08-427700-00	692	1181	
08-427700-00	692	1182	
08-427707-00	692	1181	
08-427707-00	692	1182	
08-429300-00	485	864	
08-429300-00	487	868	
08-433200-00	461	813	
08-433200-00	464	818	
08-433200-00	465	823	
08-433206-00	461	813	
08-433206-00	464	818	
08-433206-00	465	823	
08-435700-00	444	779	
08-435700-00	444	780	
08-435700-00	445	781	
08-435700-00	446	782	
08-435706-00	444	779	
08-435706-00	444	780	
08-435706-00	445	781	
08-435706-00	446	782	
08-436500-00	592	1030	
08-436500-00	592	1031	
08-436500-00	593	1032	
08-436500-00	593	1033	
08-436500-00	594	1034	
08-436500-00	595	1035	
08-436506-00	592	1030	
08-436506-00	592	1031	
08-436506-00	593	1032	
08-436506-00	593	1033	
08-436506-00	594	1034	
08-436506-00	595	1035	
08-436800-00	462	814	
08-436800-00	463	817	
08-436800-00	464	819	
08-436800-00	466	825	
08-436800-00	467	829	
08-436806-00	462	814	
08-436806-00	463	817	
08-436806-00	464	819	
08-436806-00	466	825	
08-436806-00	467	829	
08-520200-00	786	1290	
08-520200-00	788	1291	
08-520200-00	790	1292	
08-520200-00	790	1293	

			
08-520200-00	792	1294	
08-520200-00	794	1295	
08-520200-00	797	1297	
08-520200-00	798	1298	
08-520200-00	799	1299	
08-520200-00	817	1313	
08-523100-00	527	936	
08-523100-00	548	972	
08-523100-00	550	974	
08-523108-00	527	936	
08-523108-00	548	972	
08-523108-00	550	974	
08-524900-00	510	909	
08-524900-00	514	914	
08-527200-00	480	854	
08-527200-00	482	856	
08-527300-00	483	859	
08-527500-00	828	1322	
08-527500-00	830	1325	
08-527500-00	830	1326	
08-527600-00	440	772	
08-527606-00	440	772	
08-527608-00	440	772	
08-528300-00	440	771	
08-528306-00	440	771	
08-528400-00	468	831	
08-528406-00	468	831	
08-528408-00	468	831	
08-528500-00	505	898	
08-528500-00	506	900	
08-529300-00	544	965	
08-529306-00	544	965	
08-530400-00	470	835	
08-780700-00	509	907	
08-780700-00	510	908	
08-782300-00	561	993	
08-782300-00	563	994	
08-782308-00	561	993	
08-782308-00	563	994	
08-782600-00	438	767	
08-782600-00	438	768	
08-782600-00	439	769	
08-782600-00	439	770	
08-782606-00	438	767	
08-782606-00	438	768	
08-782606-00	439	769	
08-782606-00	439	770	
08-782608-00	438	767	
08-782608-00	438	768	
08-782608-00	439	769	
08-782608-00	439	770	
08-782700-00	427	750	
08-783200-00	480	853	
08-783300-00	804	1305	
08-783300-00	806	1306	
08-783300-00	821	1315	
08-783300-00	822	1318	
08-783308-00	804	1305	
08-783308-00	806	1306	
08-783308-00	821	1315	

			
08-783308-00	822	1318	
08-783400-00	571	1003	
08-783400-00	572	1004	
08-783600-00	511	910	
08-783600-00	512	911	
08-783600-00	513	912	
08-783600-00	514	913	
08-783600-00	515	915	
08-783606-00	511	910	
08-783606-00	512	911	
08-783606-00	513	912	
08-783606-00	514	913	
08-783606-00	515	915	
08-783608-00	511	910	
08-783608-00	512	911	
08-783608-00	513	912	
08-783608-00	514	913	
08-783608-00	515	915	
08-783610-00	511	910	
08-783610-00	512	911	
08-783610-00	513	912	
08-783610-00	514	913	
08-783610-00	515	915	
08-783611-00	511	910	
08-783611-00	512	911	
08-783611-00	513	912	
08-783611-00	514	913	
08-783611-00	515	915	
08-783700-00	703	1199	
08-783700-00	703	1200	
08-783700-00	705	1203	
08-783700-00	706	1204	
08-783700-00	711	1213	
08-783700-00	712	1214	
08-783700-00	713	1215	
08-783706-00	703	1199	
08-783706-00	703	1200	
08-783706-00	705	1203	
08-783706-00	706	1204	
08-783706-00	711	1213	
08-783706-00	712	1214	
08-783706-00	713	1215	
08-783708-00	703	1199	
08-783708-00	703	1200	
08-783708-00	705	1203	
08-783708-00	706	1204	
08-783708-00	711	1213	
08-783708-00	712	1214	
08-783708-00	713	1215	
08-783711-00	703	1199	
08-783711-00	703	1200	
08-783711-00	705	1203	
08-783711-00	706	1204	
08-783711-00	711	1213	
08-783711-00	712	1214	
08-783711-00	713	1215	
08-783800-00	564	996	
08-783800-00	565	997	
08-783800-00	566	998	
08-783800-00	568	1000	

			
08-783800-00	573	1006	
08-783800-00	574	1007	
08-783800-00	575	1008	
08-783800-00	578	1010	
08-783800-00	579	1011	
08-783800-00	581	1013	
08-783800-00	582	1014	
08-783808-00	564	996	
08-783808-00	565	997	
08-783808-00	566	998	
08-783808-00	568	1000	
08-783808-00	573	1006	
08-783808-00	574	1007	
08-783808-00	575	1008	
08-783808-00	578	1010	
08-783808-00	579	1011	
08-783808-00	581	1013	
08-783808-00	582	1014	
08-785400-00	561	993	
08-785400-00	563	994	
08-785400-00	569	1001	
08-785400-00	570	1002	
08-785400-00	576	1009	
08-785400-00	580	1012	
08-785408-00	561	993	
08-785408-00	563	994	
08-785408-00	569	1001	
08-785408-00	570	1002	
08-785408-00	576	1009	
08-785408-00	580	1012	
08-785500-00	478	850	
08-785500-00	479	851	
08-785506-00	478	850	
08-785506-00	479	851	
08-785507-00	478	850	
08-785507-00	479	851	
08-785508-00	478	850	
08-785508-00	479	851	
08-786700-00	511	910	
08-786700-00	512	911	
08-786700-00	513	912	
08-786700-00	514	913	
08-786700-00	515	915	
08-786800-00	707	1205	
08-786800-00	708	1208	
08-786800-00	709	1209	
08-786800-00	710	1210	
08-786806-00	707	1205	
08-786806-00	708	1208	
08-786806-00	709	1209	
08-786806-00	710	1210	
08-787000-00	518	923	
08-787000-00	519	924	
08-787000-00	545	966	
08-787000-00	545	967	
08-787000-00	546	968	
08-787006-00	518	923	
08-787006-00	519	924	
08-787006-00	545	966	
08-787006-00	545	967	





 9		
08-787006-00	546	968
08-854700-00	832	1329
08-854700-00	833	1331
08-854700-00	835	1333
08-854700-00	838	1336
08-854700-00	844	1344
08-854708-00	832	1329
08-854708-00	833	1331
08-854708-00	835	1333
08-854708-00	838	1336
08-854708-00	844	1344
14-010620-00	846	1346
14-010900-00	485	863
14-010991-00	447	785
14-010991-00	447	786
14-010991-00	448	787
14-010991-00	449	789
14-010991-00	451	793
14-010991-00	451	794
14-010991-00	452	795
14-011001-00	426	749
14-011001-00	427	750
14-011001-00	427	751
14-011001-00	428	752
14-011001-00	430	756
14-011001-00	432	758
14-011001-00	433	760
14-011001-00	433	761
14-011001-00	434	762
14-011001-00	435	763
14-011001-00	436	765
14-011001-00	437	766
14-011001-00	471	839
14-011041-00	613	1066
14-011041-00	619	1076
14-011041-00	622	1080
14-011041-00	623	1083
14-011041-00	624	1084
14-011041-00	624	1085
14-011041-00	625	1086
14-011041-00	626	1089
14-011041-00	627	1090
14-011041-00	642	1113
14-011041-00	643	1114
14-011041-00	644	1115
14-011041-00	646	1117
14-011041-00	647	1119
14-011041-00	648	1121
14-011041-00	651	1125
14-011041-00	652	1126
14-011041-00	652	1127
14-011041-00	653	1128
14-011041-00	654	1129
14-011041-00	655	1130
14-011041-00	656	1131
14-011041-00	657	1132
14-011041-00	658	1133
14-011041-00	659	1134
14-011041-00	660	1135
14-011041-00	661	1136

 9		
14-011041-00	662	1137
14-011041-00	664	1139
14-011041-00	665	1140
14-011041-00	666	1141
14-011041-00	668	1143
14-011041-00	670	1147
14-011041-00	672	1150
14-011041-00	673	1152
14-011061-00	846	1346
14-012470-00	475	845
14-012470-00	476	846
14-013481-00	827	1321
14-014720-00	584	1018
14-014730-00	561	993
14-014730-00	563	994
14-014730-00	569	1001
14-014730-00	570	1002
14-014730-00	571	1003
14-014730-00	572	1004
14-014730-00	573	1006
14-014730-00	576	1009
14-014730-00	578	1010
14-014730-00	580	1012
14-018920-00	488	871
14-018920-00	498	887
14-018920-00	499	888
14-020290-00	561	992
14-020530-00	585	1022
14-020530-00	587	1024
14-020530-00	588	1025
14-020530-00	589	1026
14-020530-00	590	1028
14-020530-00	591	1029
14-020900-00	471	838
14-021051-00	527	936
14-021051-00	527	937
14-021051-00	529	939
14-021051-00	530	941
14-021051-00	531	943
14-021051-00	532	944
14-021051-00	533	945
14-021051-00	534	946
14-021051-00	536	951
14-021051-00	538	953
14-021051-00	538	954
14-021051-00	539	955
14-021051-00	543	964
14-021051-00	548	972
14-021051-00	549	973
14-021051-00	550	974
14-021051-00	550	975
14-021051-00	551	976
14-021051-00	552	977
14-021051-00	553	978
14-021051-00	554	979
14-021051-00	555	982
14-021051-00	556	983
14-021051-00	556	984
14-021051-00	558	987
14-021051-00	558	988

 9		
14-021051-00	559	990
14-021080-00	457	806
14-021080-00	458	808
14-021080-00	459	809
14-021080-00	460	810
14-021080-00	460	811
14-021120-00	692	1181
14-021120-00	692	1182
14-021260-00	475	845
14-021260-00	476	846
14-021280-00	731	1250
14-021280-00	743	1260
14-021280-00	745	1261
14-021280-00	747	1262
14-021280-00	749	1263
14-021280-00	751	1264
14-021280-00	757	1267
14-021280-00	757	1268
14-021280-00	759	1269
14-021280-00	760	1270
14-021280-00	762	1271
14-021280-00	764	1272
14-021280-00	804	1305
14-021280-00	806	1306
14-021280-00	821	1315
14-021280-00	822	1318
14-021311-00	568	1000
14-021311-00	569	1001
14-021311-00	570	1002
14-021311-00	571	1003
14-021311-00	572	1004
14-021311-00	573	1006
14-021311-00	574	1007
14-021311-00	575	1008
14-021311-00	576	1009
14-021311-00	578	1010
14-021311-00	579	1011
14-021311-00	580	1012
14-021311-00	581	1013
14-021311-00	582	1014
14-021321-00	832	1329
14-021321-00	833	1331
14-021321-00	835	1333
14-021321-00	836	1334
14-021321-00	837	1335
14-021321-00	838	1336
14-021321-00	839	1338
14-021321-00	840	1339
14-021321-00	841	1340
14-021321-00	842	1342
14-021321-00	843	1343
14-021321-00	844	1344
14-021321-00	845	1345
14-021322-00	832	1329
14-021322-00	833	1331
14-021322-00	835	1333
14-021322-00	836	1334
14-021322-00	837	1335
14-021322-00	838	1336
14-021322-00	839	1338

 9		
14-021322-00	840	1339
14-021322-00	841	1340
14-021322-00	842	1342
14-021322-00	843	1343
14-021322-00	844	1344
14-021322-00	845	1345
14-021371-00	733	1251
14-021371-00	733	1252
14-021371-00	735	1253
14-021371-00	738	1255
14-021371-00	740	1256
14-021371-00	753	1265
14-021371-00	755	1266
14-021371-00	765	1274
14-021371-00	766	1275
14-021371-00	767	1276
14-021371-00	772	1279
14-021371-00	773	1280
14-021371-00	774	1281
14-021371-00	776	1282
14-021371-00	778	1283
14-021371-00	779	1284
14-021371-00	780	1285
14-021371-00	781	1286
14-021371-00	783	1288
14-021371-00	785	1289
14-021371-00	786	1290
14-021371-00	788	1291
14-021371-00	790	1292
14-021371-00	790	1293
14-021371-00	792	1294
14-021371-00	794	1295
14-021371-00	797	1297
14-021371-00	798	1298
14-021371-00	799	1299
14-021371-00	800	1300
14-021371-00	801	1301
14-021371-00	802	1302
14-021371-00	807	1307
14-021371-00	809	1308
14-021371-00	811	1309
14-021371-00	812	1310
14-021371-00	814	1311
14-021371-00	816	1312
14-021371-00	817	1313
14-021371-00	819	1314
14-021371-00	821	1316
14-021371-00	824	1319
14-021371-00	826	1320
14-021372-00	733	1251
14-021372-00	733	1252
14-021372-00	735	1253
14-021372-00	738	1255
14-021372-00	740	1256
14-021372-00	753	1265
14-021372-00	755	1266
14-021372-00	765	1274
14-021372-00	766	1275
14-021372-00	767	1276
14-021372-00	772	1279





 9			 9			 9			 9		
14-028960-00	538	953	55-4077	441	774	55-4186	738	1255	55-4186	841	1341
14-028960-00	538	954	55-4077	442	775	55-4186	741	1258	55-4186	842	1342
14-028960-00	539	955	55-4077	442	776	55-4186	742	1259	55-4186	843	1343
14-028960-00	543	964	55-4077	443	777	55-4186	743	1260	55-4186	844	1344
14-028960-00	548	972	55-4077	443	778	55-4186	745	1261	55-4186	845	1345
14-028960-00	549	973	55-4077	444	779	55-4186	747	1262	55-4190	561	993
14-028960-00	550	974	55-4077	444	780	55-4186	749	1263	55-4190	563	994
14-028960-00	550	975	55-4077	445	781	55-4186	751	1264	55-4190	564	995
14-028960-00	551	976	55-4077	446	783	55-4186	753	1265	55-4190	568	1000
14-028960-00	552	977	55-4078	462	815	55-4186	755	1266	55-4190	569	1001
14-028960-00	553	978	55-4078	463	816	55-4186	757	1268	55-4190	574	1007
14-028960-00	555	982	55-4078	467	828	55-4186	759	1269	55-4190	575	1008
14-028960-00	556	983	55-4134	629	1094	55-4186	760	1270	55-4190	579	1011
14-028960-00	556	984	55-4134	718	1224	55-4186	762	1271	55-4190	580	1012
14-028960-00	558	987	55-4134	719	1225	55-4186	764	1272	55-4190	581	1013
14-028960-00	558	988	55-4159	527	936	55-4186	766	1275	55-4190	583	1016
14-028960-00	559	990	55-4159	527	937	55-4186	767	1276	55-4190	583	1017
14-606670-00	629	1094	55-4159	528	938	55-4186	769	1277	55-4190	584	1018
14-636500-00	718	1224	55-4159	529	939	55-4186	772	1279	55-4193	501	891
14-636500-00	719	1225	55-4159	529	940	55-4186	773	1280	55-4193	501	892
14-676420-00	729	1245	55-4159	530	941	55-4186	774	1281	55-4193	502	895
14-676420-00	729	1246	55-4159	531	942	55-4186	776	1282	55-4193	503	896
14-676420-00	730	1248	55-4159	532	944	55-4186	778	1283	55-4193	606	1056
14-785400-00	561	993	55-4159	533	945	55-4186	781	1286	55-4193	606	1057
14-785400-00	563	994	55-4159	534	946	55-4186	783	1288	55-4193	619	1075
15-632000-00	631	1096	55-4159	534	947	55-4186	785	1289	55-4193	619	1076
15-632000-00	631	1097	55-4159	535	948	55-4186	786	1290	55-4193	620	1077
15-632000-00	633	1100	55-4159	536	950	55-4186	788	1291	55-4193	621	1078
15-632000-00	634	1101	55-4159	537	952	55-4186	790	1293	55-4193	621	1079
15-632000-00	635	1102	55-4159	538	953	55-4186	792	1294	55-4193	622	1081
15-632000-00	635	1103	55-4159	538	954	55-4186	794	1295	55-4193	623	1083
15-632000-00	636	1105	55-4159	539	955	55-4186	796	1296	55-4193	624	1084
15-632000-00	637	1106	55-4159	541	957	55-4186	797	1297	55-4193	626	1087
15-632000-00	638	1107	55-4159	541	958	55-4186	799	1299	55-4193	626	1088
15-632000-00	671	1149	55-4159	541	959	55-4186	800	1300	55-4193	627	1090
15-632000-00	673	1151	55-4159	542	960	55-4186	802	1302	55-4193	641	1111
15-632100-00	483	859	55-4159	542	961	55-4186	803	1303	55-4193	641	1112
15-632300-00	725	1237	55-4159	543	962	55-4186	804	1305	55-4193	642	1113
15-632300-00	726	1238	55-4159	543	963	55-4186	806	1306	55-4193	643	1114
15-632300-00	726	1239	55-4159	543	964	55-4186	807	1307	55-4193	644	1115
15-632300-00	727	1240	55-4159	548	972	55-4186	809	1308	55-4193	645	1116
15-632300-00	728	1243	55-4159	549	973	55-4186	811	1309	55-4193	646	1117
15-632400-00	830	1326	55-4159	550	974	55-4186	812	1310	55-4193	647	1118
15-632500-00	470	835	55-4159	550	975	55-4186	814	1311	55-4193	647	1119
15-632600-00	505	898	55-4159	551	976	55-4186	816	1312	55-4193	648	1120
15-632600-00	506	900	55-4159	552	977	55-4186	817	1313	55-4193	648	1121
55-3984	683	1168	55-4159	553	978	55-4186	819	1314	55-4193	649	1122
55-3984	683	1169	55-4159	554	979	55-4186	821	1316	55-4193	650	1123
55-3984	684	1170	55-4159	554	980	55-4186	822	1318	55-4193	650	1124
55-3984	685	1171	55-4159	555	981	55-4186	824	1319	55-4193	651	1125
55-3985	674	1154	55-4159	555	982	55-4186	826	1320	55-4193	652	1126
55-3985	676	1158	55-4159	559	990	55-4186	832	1329	55-4193	652	1127
55-3985	677	1159	55-4159	592	1030	55-4186	833	1331	55-4193	653	1128
55-3985	677	1160	55-4159	592	1031	55-4186	834	1332	55-4193	654	1129
55-3985	678	1161	55-4159	594	1034	55-4186	836	1334	55-4193	655	1130
55-3985	678	1162	55-4186	486	867	55-4186	837	1335	55-4193	656	1131
55-3985	679	1163	55-4186	731	1250	55-4186	838	1336	55-4193	657	1132
55-3985	680	1164	55-4186	733	1252	55-4186	839	1338	55-4193	658	1133
55-3985	680	1165	55-4186	735	1253	55-4186	840	1339	55-4193	659	1134
55-4077	441	773	55-4186	736	1254	55-4186	841	1340	55-4193	660	1135

# NUMERICAL PARTS LIST



Numerische Teilenummernliste • Elenco riferimenti  
Liste des références produits



		<b>9</b>
55-4193	661	1136
55-4193	662	1137
55-4193	663	1138
55-4193	664	1139
55-4193	665	1140
55-4193	666	1141
55-4193	667	1142
55-4193	668	1143
55-4193	669	1144
55-4193	669	1145
55-4193	670	1146
55-4193	670	1147
55-4193	671	1148
55-4193	672	1150
55-4193	673	1152
55-4201	436	764
55-4201	560	991
55-4201	561	992
55-4201	587	1024
55-4201	588	1025
55-4201	590	1028
55-4201	591	1029
55-4210	440	771
55-4210	440	772
55-4210	468	831
55-4210	469	832
55-4210	478	850
55-4210	479	851
55-4210	507	904
55-4210	508	905
55-4210	509	906
55-4211	846	1346
55-4211	847	1347
55-4230	847	1347
55-4231	846	1346
55-4231	847	1347
55-4231	848	1349
55-4232	568	1000
55-4232	573	1006
55-4232	574	1007
55-4232	576	1009
55-4232	578	1010
55-4232	579	1011
55-4232	581	1013
55-4232	582	1014
55-4232	583	1015
55-4233	564	996
55-4233	565	997
55-4233	566	998
55-4233	567	999
55-4233	568	1000
55-4233	570	1002
55-4233	571	1003
55-4233	572	1004
55-4233	573	1005
55-4233	574	1007
55-4233	576	1009
55-4233	579	1011
55-4233	581	1013
55-4235	721	1227



		<b>9</b>
55-4235	721	1228
55-4235	729	1245
55-4235	729	1246
55-4235	730	1248
55-4235	731	1249
55-4266	436	764
55-4275	847	1347
55-4280	469	833
55-4280	470	834
55-4280	470	835
55-4280	480	854
55-4280	481	855
55-4280	482	856
55-4280	482	857
55-4280	483	859
55-4280	484	860
55-4280	498	886
55-4280	505	898
55-4280	505	899
55-4280	506	900
55-4280	507	903
55-4280	599	1042
55-4280	600	1046
55-4280	600	1047
55-4280	628	1092
55-4280	629	1093
55-4280	631	1097
55-4280	632	1098
55-4280	632	1099
55-4280	633	1100
55-4280	634	1101
55-4280	635	1102
55-4280	635	1103
55-4280	636	1105
55-4280	637	1106
55-4280	638	1107
55-4280	639	1108
55-4280	671	1149
55-4280	673	1151
55-4280	725	1237
55-4280	726	1238
55-4280	726	1239
55-4280	727	1241
55-4280	728	1242
55-4280	728	1243
55-4280	828	1322
55-4280	829	1323
55-4280	829	1324
55-4280	830	1325
55-4280	830	1326
55-4280	831	1327
55-4280	831	1328
55-4288	468	830
55-4288	472	840
55-4288	473	841
55-4288	473	842
55-4288	473	843
55-4288	474	844
55-4288	477	847
55-4288	477	848



		<b>9</b>
55-4288	477	849
55-4288	479	852
55-4288	484	862
55-4288	488	870
55-4288	488	871
55-4288	489	872
55-4288	490	873
55-4288	491	874
55-4288	491	875
55-4288	492	876
55-4288	492	877
55-4288	498	887
55-4288	499	888
55-4288	500	889
55-4288	500	890
55-4288	501	891
55-4288	501	892
55-4288	502	894
55-4288	502	895
55-4288	503	896
55-4288	504	897
55-4288	509	907
55-4288	510	908
55-4288	510	909
55-4288	511	910
55-4288	512	911
55-4288	513	912
55-4288	514	913
55-4288	514	914
55-4288	515	915
55-4288	516	916
55-4288	605	1055
55-4288	607	1058
55-4288	608	1059
55-4288	608	1060
55-4288	609	1061
55-4288	610	1062
55-4288	610	1063
55-4288	611	1064
55-4288	612	1065
55-4288	613	1066
55-4288	614	1067
55-4288	615	1068
55-4288	616	1069
55-4288	616	1070
55-4288	617	1071
55-4288	617	1072
55-4288	617	1073
55-4288	619	1075
55-4288	619	1076
55-4288	620	1077
55-4288	621	1078
55-4288	623	1082
55-4288	639	1109
55-4288	640	1110
55-4288	641	1111
55-4288	641	1112
55-4288	642	1113
55-4288	652	1127
55-4288	671	1148

		<b>9</b>
55-4288	685	1172
55-4288	686	1173
55-4288	693	1183
55-4288	694	1184
55-4288	695	1185
55-4288	695	1186
55-4288	696	1187
55-4288	697	1188
55-4288	698	1189
55-4288	698	1190
55-4288	698	1191
55-4288	699	1192
55-4288	700	1193
55-4288	700	1194
55-4288	701	1195
55-4288	701	1196
55-4288	702	1197
55-4288	702	1198
55-4288	703	1199
55-4288	703	1200
55-4288	704	1201
55-4288	705	1202
55-4288	705	1203
55-4288	706	1204
55-4288	707	1205
55-4288	707	1206
55-4288	708	1207
55-4288	708	1208
55-4288	709	1209
55-4288	710	1210
55-4288	710	1211
55-4288	711	1212
55-4288	711	1213
55-4288	712	1214
55-4288	713	1215
55-4294	622	1080
55-4294	624	1085
55-4294	625	1086
55-4294	626	1089
55-4294	628	1091
55-4393	765	1273
55-4393	827	1321
55-4499	585	1022
55-4499	586	1023
55-4499	589	1026
55-4505	493	878
55-4505	494	879
55-4505	494	880
55-4505	495	881
55-4505	495	882
55-4505	496	883
55-4505	496	884
55-4505	497	885
55-4505	601	1048
55-4505	601	1049
55-4505	602	1050
55-4505	603	1051
55-4505	603	1052
55-4505	604	1053
55-4505	604	1054

 		
55-4505	618	1074
55-4505	713	1216
55-4505	714	1217
55-4505	715	1218
55-4505	716	1219
55-4505	716	1220
55-4505	717	1221
55-4540	518	923
55-4540	519	924
55-4540	519	925
55-4540	520	926
55-4540	521	927
55-4540	522	928
55-4540	523	929
55-4540	523	930
55-4540	524	931
55-4540	525	932
55-4540	525	933
55-4540	526	934
55-4540	544	965
55-4540	545	966
55-4540	545	967
55-4540	546	968
55-4540	547	970
55-4540	547	971
55-4540	596	1038
55-4540	597	1039
55-4540	598	1040
55-4540	598	1041
55-4540	600	1045
55-4779	485	864
55-4779	486	865
55-4779	486	867
55-4779	487	869
55-4779	584	1019
55-4970	517	920
55-4970	517	921
55-4970	518	922
71-3730/4	585	1022
71-3730/4	586	1023
71-3730/4	589	1026
71-3899/4	585	1022
71-3899/4	586	1023
71-3899/4	589	1026
71-3951/4	730	1247
71-3952/4	674	1154
71-3952/4	676	1158
71-3952/4	677	1159
71-3952/4	677	1160
71-3952/4	678	1161
71-3952/4	678	1162
71-3952/4	679	1163
71-3952/4	680	1164
71-3952/4	680	1165
71-3952/4	683	1168
71-3952/4	683	1169
71-3952/4	684	1170
71-3952/4	685	1171
71-3958/5	548	972
71-3958/5	549	973

 		
71-3958/5	551	976
71-3958/5	559	990
71-3994	527	937
71-3994	528	938
71-3994	529	939
71-3994	529	940
71-3994	530	941
71-3994	531	942
71-3994	532	944
71-3994	533	945
71-3994	534	946
71-3994	534	947
71-3994	535	948
71-3994	536	950
71-3994	537	952
71-3994	538	953
71-3994	538	954
71-3994	539	955
71-3994	541	957
71-3994	541	958
71-3994	541	959
71-3994	542	960
71-3994	542	961
71-3994	543	962
71-3994	543	963
71-3994	543	964
71-3994	548	972
71-3994	549	973
71-3994	550	974
71-3994	550	975
71-3994	551	976
71-3994	552	977
71-3994	553	978
71-3994	554	979
71-3994	554	980
71-3994	555	981
71-3994	555	982
71-3994	559	990
71-3994	594	1034
71-3994	595	1036
71-3994	596	1037
71-3996/4	519	924
71-3996/4	519	925
71-3996/4	520	926
71-3996/4	521	927
71-3996/4	522	928
71-4033/4	441	773
71-4033/4	441	774
71-4033/4	442	775
71-4033/4	442	776
71-4033/4	443	777
71-4033/4	443	778
71-4033/4	444	779
71-4033/4	444	780
71-4033/4	445	781
71-4033/4	446	783
71-4066/4	692	1181
71-4066/4	692	1182
71-4080/4	721	1229
71-4080/4	723	1232

 		
71-4080/4	724	1234
71-4080/4	725	1236
71-4082/4	849	1352
71-4082/4	850	1353
71-4082/4	850	1354
71-4118/4	568	1000
71-4118/4	579	1011
71-4118/4	580	1012
71-4118/4	644	1115
71-4118/4	647	1118
71-4118/4	647	1119
71-4118/4	649	1122
71-4118/4	650	1123
71-4118/4	654	1129
71-4118/4	655	1130
71-4118/4	656	1131
71-4118/4	665	1140
71-4118/4	666	1141
71-4118/4	668	1143
71-4118/4	669	1144
71-4118/4	672	1150
71-4120/4	622	1080
71-4120/4	623	1083
71-4120/4	624	1084
71-4120/4	624	1085
71-4120/4	625	1086
71-4120/4	626	1087
71-4120/4	626	1088
71-4120/4	626	1089
71-4120/4	627	1090
71-4120/4	628	1091
71-4120/4	643	1114
71-4120/4	648	1120
71-4120/4	653	1128
71-4120/4	658	1133
71-4120/4	659	1134
71-4120/4	660	1135
71-4120/4	661	1136
71-4120/4	662	1137
71-4121/4	480	853
71-4126/4	484	862
71-4126/4	509	907
71-4126/4	510	908
71-4130/4	731	1250
71-4130/4	735	1253
71-4130/4	736	1254
71-4130/4	738	1255
71-4130/4	741	1258
71-4130/4	742	1259
71-4130/4	743	1260
71-4130/4	745	1261
71-4130/4	747	1262
71-4130/4	749	1263
71-4130/4	751	1264
71-4130/4	753	1265
71-4130/4	755	1266
71-4130/4	757	1268
71-4130/4	759	1269
71-4130/4	760	1270
71-4130/4	762	1271

 		
71-4130/4	764	1272
71-4130/4	766	1275
71-4130/4	767	1276
71-4130/4	769	1277
71-4130/4	770	1278
71-4130/4	772	1279
71-4130/4	773	1280
71-4130/4	774	1281
71-4130/4	776	1282
71-4130/4	778	1283
71-4130/4	781	1286
71-4130/4	783	1288
71-4130/4	785	1289
71-4130/4	786	1290
71-4130/4	788	1291
71-4130/4	790	1293
71-4130/4	792	1294
71-4130/4	794	1295
71-4130/4	796	1296
71-4130/4	797	1297
71-4130/4	799	1299
71-4130/4	800	1300
71-4130/4	802	1302
71-4130/4	803	1303
71-4130/4	804	1305
71-4130/4	806	1306
71-4130/4	807	1307
71-4130/4	809	1308
71-4130/4	811	1309
71-4130/4	812	1310
71-4130/4	814	1311
71-4130/4	816	1312
71-4130/4	817	1313
71-4130/4	819	1314
71-4130/4	821	1316
71-4130/4	822	1318
71-4130/4	824	1319
71-4130/4	826	1320
71-4130/4	832	1329
71-4130/4	833	1331
71-4130/4	834	1332
71-4130/4	836	1334
71-4130/4	837	1335
71-4130/4	838	1336
71-4130/4	839	1338
71-4130/4	840	1339
71-4130/4	841	1340
71-4130/4	841	1341
71-4130/4	842	1342
71-4130/4	843	1343
71-4130/4	844	1344
71-4130/4	845	1345
71-4157/4	523	929
71-4157/4	523	930
71-4157/4	524	931
71-4157/4	525	932
71-4157/4	525	933
71-4157/4	526	934
71-4157/4	527	936
71-4157/4	531	943

# NUMERICAL PARTS LIST

Numerische Teilenummernliste • Elenco riferimenti  
 Liste des références produits

 <b>9</b>		
71-4157/4	536	<b>951</b>
71-4157/4	564	<b>996</b>
71-4157/4	565	<b>997</b>
71-4157/4	566	<b>998</b>
71-4157/4	567	<b>999</b>
71-4157/4	570	<b>1002</b>
71-4157/4	571	<b>1003</b>
71-4157/4	572	<b>1004</b>
71-4157/4	573	<b>1005</b>
71-4157/4	573	<b>1006</b>
71-4157/4	576	<b>1009</b>
71-4157/4	578	<b>1010</b>
71-4157/4	582	<b>1014</b>
71-4157/4	583	<b>1015</b>
71-4157/4	596	<b>1038</b>
71-4157/4	597	<b>1039</b>
71-4157/4	598	<b>1040</b>
71-4157/4	598	<b>1041</b>
71-4157/4	622	<b>1081</b>
71-4157/4	645	<b>1116</b>
71-4157/4	646	<b>1117</b>
71-4157/4	648	<b>1121</b>
71-4157/4	650	<b>1124</b>
71-4157/4	651	<b>1125</b>
71-4157/4	652	<b>1126</b>
71-4157/4	657	<b>1132</b>
71-4157/4	663	<b>1138</b>
71-4157/4	664	<b>1139</b>
71-4157/4	667	<b>1142</b>
71-4157/4	669	<b>1145</b>
71-4157/4	670	<b>1146</b>
71-4157/4	670	<b>1147</b>
71-4157/4	673	<b>1152</b>
71-4157/5	600	<b>1045</b>
71-4158/4	519	<b>925</b>
71-4158/4	520	<b>926</b>
71-4158/4	521	<b>927</b>
71-4158/4	522	<b>928</b>
71-4158/4	618	<b>1074</b>
71-4168/4	480	<b>854</b>
71-4168/4	481	<b>855</b>
71-4168/4	482	<b>856</b>
71-4168/4	482	<b>857</b>
71-4168/4	483	<b>859</b>
71-4168/4	484	<b>860</b>
71-4168/4	505	<b>898</b>
71-4168/4	505	<b>899</b>
71-4168/4	506	<b>900</b>
71-4168/4	599	<b>1042</b>
71-4168/4	600	<b>1046</b>
71-4168/4	600	<b>1047</b>
71-4168/4	628	<b>1092</b>
71-4168/4	629	<b>1093</b>
71-4168/4	631	<b>1097</b>
71-4168/4	632	<b>1098</b>
71-4168/4	632	<b>1099</b>
71-4168/4	633	<b>1100</b>
71-4168/4	634	<b>1101</b>
71-4168/4	635	<b>1102</b>
71-4168/4	635	<b>1103</b>

 <b>9</b>		
71-4168/4	636	<b>1105</b>
71-4168/4	637	<b>1106</b>
71-4168/4	638	<b>1107</b>
71-4168/4	639	<b>1108</b>
71-4168/4	671	<b>1149</b>
71-4168/4	673	<b>1151</b>
71-4185/4	731	<b>1250</b>
71-4185/4	733	<b>1252</b>
71-4185/4	735	<b>1253</b>
71-4185/4	736	<b>1254</b>
71-4185/4	738	<b>1255</b>
71-4185/4	741	<b>1258</b>
71-4185/4	742	<b>1259</b>
71-4185/4	743	<b>1260</b>
71-4185/4	745	<b>1261</b>
71-4185/4	747	<b>1262</b>
71-4185/4	749	<b>1263</b>
71-4185/4	751	<b>1264</b>
71-4185/4	753	<b>1265</b>
71-4185/4	755	<b>1266</b>
71-4185/4	757	<b>1268</b>
71-4185/4	759	<b>1269</b>
71-4185/4	760	<b>1270</b>
71-4185/4	762	<b>1271</b>
71-4185/4	764	<b>1272</b>
71-4185/4	774	<b>1281</b>
71-4185/4	786	<b>1290</b>
71-4185/4	794	<b>1295</b>
71-4185/4	796	<b>1296</b>
71-4185/4	800	<b>1300</b>
71-4185/4	804	<b>1305</b>
71-4185/4	806	<b>1306</b>
71-4185/4	807	<b>1307</b>
71-4185/4	809	<b>1308</b>
71-4185/4	811	<b>1309</b>
71-4185/4	814	<b>1311</b>
71-4185/4	816	<b>1312</b>
71-4185/4	817	<b>1313</b>
71-4185/4	819	<b>1314</b>
71-4185/4	822	<b>1318</b>
71-4185/4	824	<b>1319</b>
71-4185/4	826	<b>1320</b>
71-4209/5	544	<b>965</b>
71-4209/5	545	<b>966</b>
71-4209/5	545	<b>967</b>
71-4209/5	546	<b>968</b>
71-4209/5	547	<b>970</b>
71-4209/5	547	<b>971</b>
71-4218/6	507	<b>901</b>
71-4218/6	507	<b>902</b>
71-4218/6	507	<b>903</b>
71-4218/6	725	<b>1237</b>
71-4218/6	726	<b>1238</b>
71-4218/6	726	<b>1239</b>
71-4218/6	727	<b>1240</b>
71-4218/6	727	<b>1241</b>
71-4218/6	728	<b>1242</b>
71-4218/6	728	<b>1243</b>
71-4218/6	828	<b>1322</b>
71-4218/6	829	<b>1323</b>

 <b>9</b>		
71-4218/6	829	<b>1324</b>
71-4218/6	830	<b>1325</b>
71-4218/6	830	<b>1326</b>
71-4218/6	831	<b>1327</b>
71-4218/6	831	<b>1328</b>
71-4229	847	<b>1347</b>
71-4229	849	<b>1350</b>
71-4234	721	<b>1227</b>
71-4234	721	<b>1228</b>
71-4234	729	<b>1245</b>
71-4234	729	<b>1246</b>
71-4234	730	<b>1248</b>
71-4234	731	<b>1249</b>
71-4250/4	717	<b>1221</b>
71-4279/4	681	<b>1166</b>
71-4279/4	682	<b>1167</b>
71-4279/4	691	<b>1180</b>
71-4281	846	<b>1346</b>
71-4281	847	<b>1347</b>
71-4776/4	485	<b>864</b>
71-4776/4	486	<b>867</b>
71-4776/4	487	<b>869</b>
71-4776/4	584	<b>1019</b>
71-4780	537	<b>952</b>
71-4780	539	<b>955</b>
71-4780	556	<b>983</b>
71-4780	556	<b>984</b>
71-4780	557	<b>985</b>
71-4780	557	<b>986</b>
71-4780	558	<b>987</b>
71-4780	558	<b>988</b>
71-4780	592	<b>1030</b>
71-4780	592	<b>1031</b>
71-4780	594	<b>1034</b>
72-3995	534	<b>946</b>
72-3995	534	<b>947</b>
72-3995	535	<b>948</b>
72-3995	537	<b>952</b>
72-3995	539	<b>955</b>
72-3995	542	<b>961</b>
72-3995	543	<b>963</b>
72-3995	553	<b>978</b>
72-3995	554	<b>979</b>
72-3995	554	<b>980</b>
72-3995	555	<b>981</b>
72-3995	555	<b>982</b>
72-3995	556	<b>983</b>
72-3995	556	<b>984</b>
72-3995	557	<b>985</b>
72-3995	557	<b>986</b>
72-3995	558	<b>987</b>
72-3995	558	<b>988</b>
72-3995	592	<b>1030</b>
72-3995	592	<b>1031</b>
72-3995	594	<b>1034</b>
72-3995	595	<b>1036</b>
72-3995	596	<b>1037</b>
72-4547	674	<b>1154</b>
72-4547	847	<b>1347</b>
72-4547	848	<b>1348</b>

 <b>9</b>		
72-4547	848	<b>1349</b>
72-4547	849	<b>1350</b>
72-4550	674	<b>1154</b>
72-4550	846	<b>1346</b>
72-4550	847	<b>1347</b>
72-4550	848	<b>1348</b>
72-4550	849	<b>1350</b>
87-104000-00	561	<b>992</b>
87-104008-00	561	<b>992</b>
87-105500-00	585	<b>1022</b>
87-105500-00	589	<b>1026</b>
87-105507-00	585	<b>1022</b>
87-105507-00	589	<b>1026</b>
87-107100-30	631	<b>1096</b>
87-107100-40	635	<b>1103</b>
87-107806-10	497	<b>885</b>
87-107900-00	530	<b>941</b>
87-107900-00	538	<b>954</b>
87-107900-00	543	<b>964</b>
87-107900-00	551	<b>976</b>
87-107900-00	559	<b>990</b>
87-107908-00	530	<b>941</b>
87-107908-00	538	<b>954</b>
87-107908-00	543	<b>964</b>
87-107908-00	551	<b>976</b>
87-107908-00	559	<b>990</b>
87-108000-00	527	<b>937</b>
87-108000-00	549	<b>973</b>
87-108000-00	550	<b>975</b>
87-108008-00	527	<b>937</b>
87-108008-00	549	<b>973</b>
87-108008-00	550	<b>975</b>
87-108200-00	843	<b>1343</b>
87-108200-00	845	<b>1345</b>
87-108208-00	843	<b>1343</b>
87-108208-00	845	<b>1345</b>
87-110100-00	730	<b>1248</b>
87-110200-30	636	<b>1105</b>
87-110200-30	671	<b>1149</b>
87-110200-40	634	<b>1101</b>
87-110200-40	637	<b>1106</b>
87-110500-30	725	<b>1237</b>
87-110500-30	726	<b>1238</b>
87-110500-30	726	<b>1239</b>
87-110500-30	727	<b>1240</b>
87-110500-30	728	<b>1243</b>
87-110900-00	596	<b>1038</b>
87-110900-00	599	<b>1042</b>
87-110906-00	596	<b>1038</b>
87-110906-00	599	<b>1042</b>
87-114700-00	679	<b>1163</b>
87-114700-00	680	<b>1165</b>
87-114700-10	678	<b>1161</b>
87-114700-10	680	<b>1164</b>
87-114700-30	683	<b>1169</b>
87-114700-30	684	<b>1170</b>
87-114700-30	685	<b>1171</b>
87-114700-40	677	<b>1160</b>
87-114708-00	679	<b>1163</b>
87-114708-00	680	<b>1165</b>



 <b>9</b>		
87-114708-10	678	<b>1161</b>
87-114708-10	680	<b>1164</b>
87-114708-30	683	<b>1169</b>
87-114708-30	684	<b>1170</b>
87-114708-30	685	<b>1171</b>
87-118000-00	523	<b>929</b>
87-118000-00	523	<b>930</b>
87-118000-00	525	<b>933</b>
87-118000-10	520	<b>926</b>
87-118000-30	547	<b>970</b>
87-118006-00	523	<b>929</b>
87-118006-00	523	<b>930</b>
87-118006-00	525	<b>933</b>
87-118006-10	520	<b>926</b>
87-118006-30	547	<b>970</b>
87-122200-00	839	<b>1338</b>
87-122200-00	840	<b>1339</b>
87-122200-00	841	<b>1340</b>
87-122200-00	842	<b>1342</b>
87-122200-10	832	<b>1329</b>
87-122200-10	833	<b>1331</b>
87-122200-10	835	<b>1333</b>
87-122200-10	838	<b>1336</b>
87-122200-10	844	<b>1344</b>
87-122200-20	836	<b>1334</b>
87-122200-20	837	<b>1335</b>
87-122208-00	839	<b>1338</b>
87-122208-00	840	<b>1339</b>
87-122208-00	841	<b>1340</b>
87-122208-00	842	<b>1342</b>
87-122208-10	832	<b>1329</b>
87-122208-10	833	<b>1331</b>
87-122208-10	835	<b>1333</b>
87-122208-10	838	<b>1336</b>
87-122208-10	844	<b>1344</b>
87-124000-00	531	<b>943</b>
87-124000-00	536	<b>951</b>
87-124000-10	530	<b>941</b>
87-124000-10	543	<b>964</b>
87-124000-30	529	<b>939</b>
87-124000-30	533	<b>945</b>
87-124000-30	538	<b>953</b>
87-124000-30	538	<b>954</b>
87-124000-30	551	<b>976</b>
87-124000-30	552	<b>977</b>
87-124000-30	559	<b>990</b>
87-124008-00	531	<b>943</b>
87-124008-00	536	<b>951</b>
87-124008-10	530	<b>941</b>
87-124008-10	543	<b>964</b>
87-124008-30	529	<b>939</b>
87-124008-30	533	<b>945</b>
87-124008-30	538	<b>953</b>
87-124008-30	538	<b>954</b>
87-124008-30	551	<b>976</b>
87-124008-30	552	<b>977</b>
87-124008-30	559	<b>990</b>
87-124800-00	516	<b>916</b>
87-124806-00	516	<b>916</b>
87-126608-00	681	<b>1166</b>

 <b>9</b>		
87-126608-00	682	<b>1167</b>
87-137600-00	442	<b>776</b>
87-137600-00	443	<b>777</b>
87-137606-00	442	<b>776</b>
87-137606-00	443	<b>777</b>
87-138000-00	721	<b>1229</b>
87-138000-00	723	<b>1231</b>
87-138000-10	723	<b>1232</b>
87-138006-00	721	<b>1229</b>
87-138006-00	723	<b>1231</b>
87-138006-10	723	<b>1232</b>
87-138008-00	721	<b>1229</b>
87-138008-00	723	<b>1231</b>
87-138008-10	723	<b>1232</b>
87-138400-00	455	<b>801</b>
87-138400-00	455	<b>802</b>
87-138400-00	458	<b>807</b>
87-138400-10	453	<b>798</b>
87-138400-30	460	<b>810</b>
87-138400-30	460	<b>811</b>
87-138400-40	454	<b>799</b>
87-138400-40	456	<b>803</b>
87-138400-40	457	<b>805</b>
87-138400-40	458	<b>808</b>
87-138400-40	459	<b>809</b>
87-138406-00	455	<b>801</b>
87-138406-00	455	<b>802</b>
87-138406-00	458	<b>807</b>
87-138406-10	453	<b>798</b>
87-138406-30	460	<b>810</b>
87-138406-30	460	<b>811</b>
87-138406-40	454	<b>799</b>
87-138406-40	456	<b>803</b>
87-138406-40	457	<b>805</b>
87-138406-40	458	<b>808</b>
87-138406-40	458	<b>808</b>
87-138406-40	459	<b>809</b>
87-138408-10	453	<b>798</b>
87-142300-00	448	<b>787</b>
87-142300-00	449	<b>789</b>
87-142306-00	448	<b>787</b>
87-142306-00	449	<b>789</b>
87-142308-00	448	<b>787</b>
87-142308-00	449	<b>789</b>
87-142400-00	651	<b>1125</b>
87-142400-00	652	<b>1126</b>
87-142400-00	670	<b>1147</b>
87-142400-00	673	<b>1152</b>
87-142406-00	651	<b>1125</b>
87-142406-00	652	<b>1126</b>
87-142406-00	670	<b>1147</b>
87-142406-00	673	<b>1152</b>
87-145100-00	430	<b>756</b>
87-145100-00	435	<b>763</b>
87-145106-00	430	<b>756</b>
87-145106-00	435	<b>763</b>
87-145108-00	430	<b>756</b>
87-145108-00	435	<b>763</b>
87-145200-00	595	<b>1036</b>
87-145200-00	596	<b>1037</b>
87-145206-00	595	<b>1036</b>

 <b>9</b>		
87-145206-00	596	<b>1037</b>
87-145300-00	598	<b>1040</b>
87-145306-00	598	<b>1040</b>
87-145400-00	522	<b>928</b>
87-145400-30	521	<b>927</b>
87-145406-00	522	<b>928</b>
87-145406-30	521	<b>927</b>
87-146100-00	534	<b>946</b>
87-146100-00	553	<b>978</b>
87-146100-00	554	<b>979</b>
87-146100-10	558	<b>987</b>
87-146100-10	540	<b>956</b>
87-146106-10	540	<b>956</b>
87-146108-00	534	<b>946</b>
87-146108-00	553	<b>978</b>
87-146108-00	558	<b>987</b>
87-152000-10	587	<b>1024</b>
87-152000-10	591	<b>1029</b>
87-152007-10	587	<b>1024</b>
87-152007-10	591	<b>1029</b>
87-152010-10	587	<b>1024</b>
87-152010-10	591	<b>1029</b>
87-152700-00	827	<b>1321</b>
87-152707-00	827	<b>1321</b>
87-154200-00	451	<b>793</b>
87-154200-10	447	<b>785</b>
87-154200-30	447	<b>786</b>
87-154206-00	451	<b>793</b>
87-154206-10	447	<b>785</b>
87-154206-30	447	<b>786</b>
87-154208-00	451	<b>793</b>
87-154208-10	447	<b>785</b>
87-154208-30	447	<b>786</b>
87-154600-00	687	<b>1176</b>
87-154608-00	687	<b>1176</b>
87-203100-00	488	<b>871</b>
87-203106-00	488	<b>871</b>
87-203106-10	507	<b>904</b>
87-203106-10	508	<b>905</b>
87-203106-10	509	<b>906</b>
87-203108-00	488	<b>871</b>
87-203108-10	507	<b>904</b>
87-203108-10	508	<b>905</b>
87-203108-10	509	<b>906</b>
87-207200-00	846	<b>1346</b>
87-207208-00	846	<b>1346</b>
87-209800-00	427	<b>751</b>
87-209800-00	428	<b>752</b>
87-209800-00	432	<b>758</b>
87-209800-00	433	<b>760</b>
87-209800-00	436	<b>765</b>
87-209800-00	437	<b>766</b>
87-209800-00	471	<b>839</b>
87-209800-10	433	<b>761</b>
87-209800-10	434	<b>762</b>
87-209800-10	436	<b>765</b>
87-209800-10	436	<b>765</b>
87-209800-30	426	<b>749</b>
87-209806-00	427	<b>751</b>
87-209806-00	428	<b>752</b>
87-209806-00	432	<b>758</b>

 <b>9</b>		
87-209806-00	433	<b>760</b>
87-209806-00	436	<b>765</b>
87-209806-00	437	<b>766</b>
87-209806-00	471	<b>839</b>
87-209806-10	433	<b>761</b>
87-209806-10	434	<b>762</b>
87-209806-10	436	<b>765</b>
87-209806-30	426	<b>749</b>
87-209808-00	427	<b>751</b>
87-209808-00	428	<b>752</b>
87-209808-00	432	<b>758</b>
87-209808-00	433	<b>760</b>
87-209808-00	436	<b>765</b>
87-209808-00	437	<b>766</b>
87-209808-00	471	<b>839</b>
87-209808-10	433	<b>761</b>
87-209808-10	434	<b>762</b>
87-209808-10	436	<b>765</b>
87-214500-00	731	<b>1250</b>
87-214500-00	743	<b>1260</b>
87-214500-00	745	<b>1261</b>
87-214500-00	747	<b>1262</b>
87-214500-00	749	<b>1263</b>
87-214500-00	751	<b>1264</b>
87-214500-00	757	<b>1267</b>
87-214500-00	757	<b>1268</b>
87-214500-00	759	<b>1269</b>
87-214500-00	760	<b>1270</b>
87-214508-00	731	<b>1250</b>
87-214508-00	743	<b>1260</b>
87-214508-00	745	<b>1261</b>
87-214508-00	747	<b>1262</b>
87-214508-00	749	<b>1263</b>
87-214508-00	751	<b>1264</b>
87-214508-00	757	<b>1267</b>
87-214508-00	757	<b>1268</b>
87-214508-00	759	<b>1269</b>
87-214508-00	760	<b>1270</b>
87-215100-10	584	<b>1018</b>
87-215108-10	584	<b>1018</b>
87-215200-00	476	<b>846</b>
87-215300-00	646	<b>1117</b>
87-215300-00	667	<b>1142</b>
87-215300-10	644	<b>1115</b>
87-215300-10	647	<b>1119</b>
87-215300-10	654	<b>1129</b>
87-215300-10	665	<b>1140</b>
87-215300-10	668	<b>1143</b>
87-215300-10	672	<b>1150</b>
87-215306-00	646	<b>1117</b>
87-215306-00	667	<b>1142</b>
87-215308-00	646	<b>1117</b>
87-215308-00	667	<b>1142</b>
87-215308-10	644	<b>1115</b>
87-215308-10	647	<b>1119</b>
87-215308-10	654	<b>1129</b>
87-215308-10	665	<b>1140</b>
87-215308-10	668	<b>1143</b>
87-215308-10	672	<b>1150</b>

# NUMERICAL PARTS LIST

Numerische Teilenummernliste • Elenco riferimenti  
Liste des références produits

			9
87-245200-30	733	1251	
87-245200-30	733	1252	
87-245200-30	735	1253	
87-245200-30	738	1255	
87-245200-30	753	1265	
87-245200-30	755	1266	
87-245200-40	740	1257	
87-245200-40	776	1282	
87-245200-40	778	1283	
87-245200-40	779	1284	
87-245200-40	780	1285	
87-245200-40	781	1286	
87-245200-40	783	1288	
87-245200-40	785	1289	
87-245200-40	814	1311	
87-245200-40	816	1312	
87-245200-50	740	1257	
87-245200-50	776	1282	
87-245200-50	778	1283	
87-245200-50	779	1284	
87-245200-50	780	1285	
87-245200-50	781	1286	
87-245200-50	783	1288	
87-245200-50	785	1289	
87-245200-50	814	1311	
87-245200-50	816	1312	
87-245200-60	740	1256	
87-245208-30	733	1251	
87-245208-30	733	1252	
87-245208-30	735	1253	
87-245208-30	738	1255	
87-245208-30	753	1265	
87-245208-30	755	1266	
87-245208-40	740	1257	
87-245208-40	776	1282	
87-245208-40	778	1283	
87-245208-40	779	1284	
87-245208-40	780	1285	
87-245208-40	781	1286	
87-245208-40	783	1288	
87-245208-40	785	1289	
87-245208-40	814	1311	
87-245208-40	816	1312	
87-245208-50	740	1257	
87-245208-50	776	1282	
87-245208-50	778	1283	
87-245208-50	779	1284	
87-245208-50	780	1285	
87-245208-50	781	1286	
87-245208-50	783	1288	
87-245208-50	785	1289	
87-245208-50	814	1311	
87-245208-50	816	1312	
87-315200-00	485	863	
87-421600-00	850	1354	
87-425000-00	765	1274	
87-425000-00	766	1275	
87-425000-00	767	1276	
87-425000-00	773	1280	
87-425000-00	812	1310	

			9
87-425000-00	821	1316	
87-425000-10	800	1300	
87-425000-10	801	1301	
87-425000-10	802	1302	
87-425000-10	819	1314	
87-425008-00	765	1274	
87-425008-00	766	1275	
87-425008-00	767	1276	
87-425008-00	773	1280	
87-425008-00	812	1310	
87-425008-00	821	1316	
87-425008-10	800	1300	
87-425008-10	801	1301	
87-425008-10	802	1302	
87-425008-10	819	1314	
87-425600-00	443	778	
87-425606-00	443	778	
87-427700-10	692	1181	
87-427700-30	692	1182	
87-427707-10	692	1181	
87-436500-00	592	1030	
87-436500-00	592	1031	
87-436500-00	594	1034	
87-436500-00	595	1035	
87-436506-00	592	1030	
87-436506-00	592	1031	
87-436506-00	594	1034	
87-436506-00	595	1035	
87-436800-00	466	825	
87-436806-00	466	825	
87-520200-00	786	1290	
87-520200-00	788	1291	
87-520200-00	790	1292	
87-520200-00	790	1293	
87-520200-00	792	1294	
87-520200-00	794	1295	
87-520200-00	797	1297	
87-520200-00	798	1298	
87-520200-00	799	1299	
87-520200-00	817	1313	
87-523100-00	527	936	
87-523100-00	548	972	
87-523100-00	550	974	
87-523108-00	527	936	
87-523108-00	548	972	
87-523108-00	550	974	
87-527200-00	480	854	
87-527200-00	482	856	
87-527300-00	483	859	
87-527600-00	440	772	
87-527606-00	440	772	
87-527608-00	440	772	
87-528300-00	440	771	
87-528306-00	440	771	
87-528400-00	468	831	
87-528406-00	468	831	
87-528408-00	468	831	
87-528500-00	505	898	
87-528500-00	506	900	
87-529300-00	544	965	

			9
87-529306-00	544	965	
87-530400-00	470	835	
87-782300-00	563	994	
87-782308-00	563	994	
87-782606-00	438	767	
87-782608-00	438	767	
87-782700-00	427	750	
87-782708-00	427	750	
87-783300-00	804	1305	
87-783300-00	806	1306	
87-783300-00	821	1315	
87-783300-00	822	1318	
87-783308-00	804	1305	
87-783308-00	806	1306	
87-783308-00	821	1315	
87-783308-00	822	1318	
87-783400-00	572	1004	
87-783600-00	512	911	
87-783600-00	513	912	
87-783600-00	514	913	
87-783600-00	515	915	
87-783606-00	512	911	
87-783606-00	513	912	
87-783606-00	514	913	
87-783606-00	515	915	
87-783608-00	512	911	
87-783608-00	513	912	
87-783608-00	514	913	
87-783608-00	515	915	
87-783700-00	703	1199	
87-783700-00	703	1200	
87-783700-00	705	1203	
87-783700-00	706	1204	
87-783700-00	711	1213	
87-783700-00	712	1214	
87-783700-00	713	1215	
87-783706-00	703	1199	
87-783706-00	703	1200	
87-783706-00	705	1203	
87-783706-00	706	1204	
87-783706-00	711	1213	
87-783706-00	712	1214	
87-783706-00	713	1215	
87-783708-00	703	1199	
87-783708-00	703	1200	
87-783708-00	705	1203	
87-783708-00	706	1204	
87-783708-00	711	1213	
87-783708-00	712	1214	
87-783708-00	713	1215	
87-783800-00	564	996	
87-783800-00	566	998	
87-783800-10	565	997	
87-783800-10	573	1006	
87-783800-10	574	1007	
87-783800-10	575	1008	
87-783800-10	578	1010	
87-783800-10	582	1014	
87-783800-30	564	996	
87-783800-30	566	998	

			9
87-783800-30	573	1006	
87-783800-30	574	1007	
87-783800-30	575	1008	
87-783800-30	578	1010	
87-783800-30	581	1013	
87-783800-30	582	1014	
87-783808-00	564	996	
87-783808-00	566	998	
87-783808-10	565	997	
87-783808-10	573	1006	
87-783808-10	574	1007	
87-783808-10	575	1008	
87-783808-10	578	1010	
87-783808-10	582	1014	
87-783808-30	564	996	
87-783808-30	566	998	
87-783808-30	573	1006	
87-783808-30	574	1007	
87-783808-30	575	1008	
87-783808-30	578	1010	
87-783808-30	581	1013	
87-783808-30	582	1014	
87-785400-00	563	994	
87-785400-00	569	1001	
87-785400-00	576	1009	
87-785400-00	580	1012	
87-785408-00	563	994	
87-785408-00	569	1001	
87-785408-00	576	1009	
87-785408-00	580	1012	
87-785500-00	478	850	
87-785506-00	478	850	
87-785508-00	478	850	
87-786800-00	707	1205	
87-786800-00	708	1208	
87-786800-00	709	1209	
87-786800-00	710	1210	
87-786806-00	707	1205	
87-786806-00	708	1208	
87-786806-00	709	1209	
87-786806-00	710	1210	
87-787000-00	545	966	
87-787000-00	545	967	
87-787000-00	546	968	
87-787000-10	519	924	
87-787000-30	518	923	
87-787006-00	545	966	
87-787006-00	545	967	
87-787006-00	546	968	
87-787006-10	519	924	
87-787006-30	518	923	
87-854700-00	832	1329	
87-854700-00	833	1331	
87-854700-00	835	1333	
87-854700-00	838	1336	
87-854700-00	844	1344	
87-854708-00	832	1329	
87-854708-00	833	1331	
87-854708-00	835	1333	
87-854708-00	838	1336	

		<b>9</b>
87-854708-00	844	<b>1344</b>
88-152000-30	587	<b>1024</b>
88-152000-30	591	<b>1029</b>
88-527600-00	440	<b>772</b>
88-528300-00	440	<b>771</b>
88-528400-00	468	<b>831</b>
88-530300-00	526	<b>935</b>
88-785500-00	478	<b>850</b>
89-107100-30	631	<b>1096</b>
89-107100-40	635	<b>1103</b>
89-110100-00	730	<b>1248</b>
89-110200-30	636	<b>1105</b>
89-110200-30	671	<b>1149</b>
89-110200-40	634	<b>1101</b>
89-110200-40	637	<b>1106</b>
89-110500-30	725	<b>1237</b>
89-110500-30	726	<b>1238</b>
89-110500-30	726	<b>1239</b>
89-110500-30	727	<b>1240</b>
89-110500-30	728	<b>1243</b>
89-316900-00	719	<b>1225</b>
89-316900-10	719	<b>1225</b>
89-527200-00	480	<b>854</b>
89-527200-00	482	<b>856</b>
89-527300-00	483	<b>859</b>
89-528500-00	505	<b>898</b>
89-528500-00	506	<b>900</b>
89-530400-00	470	<b>835</b>
A160/4	560	<b>991</b>
A160/4	561	<b>992</b>
A161/2	675	<b>1155</b>
A161/2	676	<b>1156</b>
A161/2	676	<b>1157</b>
A178/4	469	<b>833</b>
A178/4	470	<b>834</b>
A178/4	470	<b>835</b>
A178/4	480	<b>854</b>
A178/4	481	<b>855</b>
A178/4	482	<b>856</b>
A178/4	482	<b>857</b>
A178/4	483	<b>859</b>
A178/4	484	<b>860</b>
A178/4	498	<b>886</b>
A178/4	505	<b>898</b>
A178/4	505	<b>899</b>
A178/4	506	<b>900</b>
A178/4	599	<b>1042</b>
A178/4	600	<b>1046</b>
A178/4	600	<b>1047</b>
A178/4	628	<b>1092</b>
A178/4	629	<b>1093</b>
A178/4	631	<b>1097</b>
A178/4	632	<b>1098</b>
A178/4	632	<b>1099</b>
A178/4	633	<b>1100</b>
A178/4	634	<b>1101</b>
A178/4	635	<b>1102</b>
A178/4	635	<b>1103</b>
A178/4	636	<b>1105</b>
A178/4	637	<b>1106</b>

		<b>9</b>
A178/4	638	<b>1107</b>
A178/4	639	<b>1108</b>
A178/4	671	<b>1149</b>
A178/4	673	<b>1151</b>
A182/2	426	<b>748</b>
A182/2	426	<b>749</b>
A182/2	427	<b>751</b>
A182/2	428	<b>752</b>
A182/2	429	<b>753</b>
A182/2	429	<b>754</b>
A182/2	430	<b>755</b>
A182/2	430	<b>756</b>
A182/2	431	<b>757</b>
A182/2	432	<b>758</b>
A182/2	432	<b>759</b>
A182/2	433	<b>760</b>
A182/2	433	<b>761</b>
A182/2	434	<b>762</b>
A182/2	435	<b>763</b>
A182/2	436	<b>765</b>
A182/2	437	<b>766</b>
A182/2	439	<b>769</b>
A182/2	439	<b>770</b>
A182/2	471	<b>839</b>
A188/4	585	<b>1022</b>
A188/4	586	<b>1023</b>
A188/4	588	<b>1025</b>
A188/4	589	<b>1026</b>
A188/4	590	<b>1028</b>
A188/4	591	<b>1029</b>
A188/4	681	<b>1166</b>
A188/4	682	<b>1167</b>
A188/4	687	<b>1175</b>
A188/4	687	<b>1176</b>
A188/4	688	<b>1177</b>
A188/4	689	<b>1178</b>
A188/4	690	<b>1179</b>
A188/4	691	<b>1180</b>
A190/2	518	<b>923</b>
A190/2	519	<b>924</b>
A190/2	519	<b>925</b>
A190/2	520	<b>926</b>
A190/2	521	<b>927</b>
A190/2	522	<b>928</b>
A190/2	523	<b>929</b>
A190/2	523	<b>930</b>
A190/2	524	<b>931</b>
A190/2	525	<b>932</b>
A190/2	525	<b>933</b>
A190/2	526	<b>934</b>
A190/2	527	<b>936</b>
A190/2	531	<b>943</b>
A190/2	536	<b>951</b>
A190/2	596	<b>1037</b>
A190/2	596	<b>1038</b>
A190/2	597	<b>1039</b>
A190/2	598	<b>1040</b>
A190/2	598	<b>1041</b>
A190/2	618	<b>1074</b>
A191/2	527	<b>937</b>

		<b>9</b>
A191/2	528	<b>938</b>
A191/2	529	<b>939</b>
A191/2	529	<b>940</b>
A191/2	530	<b>941</b>
A191/2	531	<b>942</b>
A191/2	532	<b>944</b>
A191/2	533	<b>945</b>
A191/2	534	<b>946</b>
A191/2	534	<b>947</b>
A191/2	535	<b>948</b>
A191/2	536	<b>950</b>
A191/2	537	<b>952</b>
A191/2	538	<b>953</b>
A191/2	538	<b>954</b>
A191/2	539	<b>955</b>
A191/2	541	<b>957</b>
A191/2	541	<b>958</b>
A191/2	541	<b>959</b>
A191/2	542	<b>960</b>
A191/2	542	<b>961</b>
A191/2	543	<b>962</b>
A191/2	543	<b>963</b>
A191/2	543	<b>964</b>
A191/2	544	<b>965</b>
A191/2	545	<b>966</b>
A191/2	545	<b>967</b>
A191/2	546	<b>968</b>
A191/2	547	<b>970</b>
A191/2	547	<b>971</b>
A191/2	548	<b>972</b>
A191/2	549	<b>973</b>
A191/2	550	<b>974</b>
A191/2	550	<b>975</b>
A191/2	551	<b>976</b>
A191/2	552	<b>977</b>
A191/2	553	<b>978</b>
A191/2	554	<b>979</b>
A191/2	554	<b>980</b>
A191/2	555	<b>981</b>
A191/2	555	<b>982</b>
A191/2	559	<b>990</b>
A191/2	592	<b>1030</b>
A191/2	592	<b>1031</b>
A191/2	594	<b>1034</b>
A191/2	595	<b>1036</b>
A191/2	600	<b>1045</b>
A192/4	846	<b>1346</b>
A192/4	847	<b>1347</b>
A193/4	846	<b>1346</b>
A193/4	847	<b>1347</b>
A197/2	468	<b>830</b>
A198/2	468	<b>830</b>
A198/2	484	<b>862</b>
A198/2	488	<b>870</b>
A198/2	488	<b>871</b>
A198/2	489	<b>872</b>
A198/2	490	<b>873</b>
A198/2	492	<b>876</b>
A198/2	492	<b>877</b>
A198/2	498	<b>887</b>

		<b>9</b>
A198/2	499	<b>888</b>
A198/2	500	<b>889</b>
A198/2	504	<b>897</b>
A198/2	509	<b>907</b>
A198/2	510	<b>908</b>
A198/2	510	<b>909</b>
A198/2	511	<b>910</b>
A198/2	512	<b>911</b>
A198/2	513	<b>912</b>
A198/2	514	<b>913</b>
A198/2	514	<b>914</b>
A198/2	515	<b>915</b>
A198/2	516	<b>916</b>
A198/2	685	<b>1172</b>
A198/2	686	<b>1173</b>
A198/2	693	<b>1183</b>
A198/2	694	<b>1184</b>
A198/2	695	<b>1186</b>
A198/2	696	<b>1187</b>
A198/2	697	<b>1188</b>
A198/2	698	<b>1190</b>
A198/2	698	<b>1191</b>
A198/2	699	<b>1192</b>
A198/2	700	<b>1193</b>
A198/2	700	<b>1194</b>
A198/2	701	<b>1195</b>
A198/2	701	<b>1196</b>
A198/2	702	<b>1197</b>
A198/2	702	<b>1198</b>
A198/2	703	<b>1199</b>
A198/2	703	<b>1200</b>
A198/2	704	<b>1201</b>
A198/2	705	<b>1202</b>
A198/2	705	<b>1203</b>
A198/2	706	<b>1204</b>
A198/2	707	<b>1205</b>
A198/2	707	<b>1206</b>
A198/2	708	<b>1207</b>
A198/2	708	<b>1208</b>
A198/2	709	<b>1209</b>
A198/2	710	<b>1210</b>
A198/2	710	<b>1211</b>
A198/2	711	<b>1212</b>
A198/2	711	<b>1213</b>
A198/2	712	<b>1214</b>
A198/2	713	<b>1215</b>
A199/4	629	<b>1094</b>
A199/4	718	<b>1224</b>
A199/4	719	<b>1225</b>
A201/2	473	<b>842</b>
A201/2	473	<b>843</b>
A201/2	479	<b>852</b>
A201/2	480	<b>853</b>
A201/2	500	<b>890</b>
A201/2	501	<b>891</b>
A201/2	501	<b>892</b>
A201/2	502	<b>894</b>
A201/2	502	<b>895</b>
A201/2	503	<b>896</b>
A201/2	561	<b>993</b>

# NUMERICAL PARTS LIST

Numerische Teilenummernliste • Elenco riferimenti  
Liste des références produits

 <b>9</b>		
A201/2	563	<b>994</b>
A201/2	564	<b>995</b>
A201/2	564	<b>996</b>
A201/2	565	<b>997</b>
A201/2	566	<b>998</b>
A201/2	567	<b>999</b>
A201/2	568	<b>1000</b>
A201/2	569	<b>1001</b>
A201/2	570	<b>1002</b>
A201/2	571	<b>1003</b>
A201/2	572	<b>1004</b>
A201/2	573	<b>1005</b>
A201/2	573	<b>1006</b>
A201/2	574	<b>1007</b>
A201/2	575	<b>1008</b>
A201/2	576	<b>1009</b>
A201/2	578	<b>1010</b>
A201/2	579	<b>1011</b>
A201/2	580	<b>1012</b>
A201/2	581	<b>1013</b>
A201/2	582	<b>1014</b>
A201/2	583	<b>1015</b>
A201/2	583	<b>1016</b>
A201/2	583	<b>1017</b>
A201/2	584	<b>1018</b>
A201/2	605	<b>1055</b>
A201/2	606	<b>1056</b>
A201/2	606	<b>1057</b>
A201/2	607	<b>1058</b>
A201/2	608	<b>1059</b>
A201/2	608	<b>1060</b>
A201/2	609	<b>1061</b>
A201/2	610	<b>1062</b>
A201/2	610	<b>1063</b>
A201/2	611	<b>1064</b>
A201/2	612	<b>1065</b>
A201/2	613	<b>1066</b>
A201/2	614	<b>1067</b>
A201/2	615	<b>1068</b>
A201/2	616	<b>1069</b>
A201/2	616	<b>1070</b>
A201/2	617	<b>1071</b>
A201/2	617	<b>1072</b>
A201/2	617	<b>1073</b>
A201/2	619	<b>1075</b>
A201/2	619	<b>1076</b>
A201/2	620	<b>1077</b>
A201/2	621	<b>1078</b>
A201/2	621	<b>1079</b>
A201/2	622	<b>1080</b>
A201/2	622	<b>1081</b>
A201/2	623	<b>1082</b>
A201/2	623	<b>1083</b>
A201/2	624	<b>1084</b>
A201/2	624	<b>1085</b>
A201/2	625	<b>1086</b>
A201/2	626	<b>1087</b>
A201/2	626	<b>1088</b>
A201/2	626	<b>1089</b>
A201/2	627	<b>1090</b>

 <b>9</b>		
A201/2	628	<b>1091</b>
A201/2	639	<b>1109</b>
A201/2	640	<b>1110</b>
A201/2	641	<b>1111</b>
A201/2	641	<b>1112</b>
A201/2	642	<b>1113</b>
A201/2	643	<b>1114</b>
A201/2	644	<b>1115</b>
A201/2	645	<b>1116</b>
A201/2	646	<b>1117</b>
A201/2	647	<b>1118</b>
A201/2	647	<b>1119</b>
A201/2	648	<b>1120</b>
A201/2	648	<b>1121</b>
A201/2	649	<b>1122</b>
A201/2	650	<b>1123</b>
A201/2	650	<b>1124</b>
A201/2	651	<b>1125</b>
A201/2	652	<b>1126</b>
A201/2	652	<b>1127</b>
A201/2	653	<b>1128</b>
A201/2	654	<b>1129</b>
A201/2	655	<b>1130</b>
A201/2	656	<b>1131</b>
A201/2	657	<b>1132</b>
A201/2	658	<b>1133</b>
A201/2	659	<b>1134</b>
A201/2	660	<b>1135</b>
A201/2	661	<b>1136</b>
A201/2	662	<b>1137</b>
A201/2	663	<b>1138</b>
A201/2	664	<b>1139</b>
A201/2	665	<b>1140</b>
A201/2	666	<b>1141</b>
A201/2	667	<b>1142</b>
A201/2	668	<b>1143</b>
A201/2	669	<b>1144</b>
A201/2	669	<b>1145</b>
A201/2	670	<b>1146</b>
A201/2	670	<b>1147</b>
A201/2	671	<b>1148</b>
A201/2	672	<b>1150</b>
A201/2	673	<b>1152</b>
A203/2	471	<b>837</b>
A205/2	493	<b>878</b>
A205/2	494	<b>879</b>
A205/2	494	<b>880</b>
A205/2	495	<b>881</b>
A205/2	495	<b>882</b>
A205/2	496	<b>883</b>
A205/2	496	<b>884</b>
A205/2	497	<b>885</b>
A205/2	601	<b>1048</b>
A205/2	601	<b>1049</b>
A205/2	602	<b>1050</b>
A205/2	603	<b>1051</b>
A205/2	603	<b>1052</b>
A205/2	604	<b>1053</b>
A205/2	604	<b>1054</b>
A205/2	713	<b>1216</b>

 <b>9</b>		
A205/2	714	<b>1217</b>
A205/2	715	<b>1218</b>
A205/2	716	<b>1219</b>
A205/2	716	<b>1220</b>
A205/2	717	<b>1221</b>
A206/2	438	<b>767</b>
A206/2	438	<b>768</b>
A213/4	765	<b>1273</b>
A213/4	827	<b>1321</b>
A214/4	436	<b>764</b>
A214/4	585	<b>1021</b>
A214/4	587	<b>1024</b>
A214/4	674	<b>1154</b>
A214/4	676	<b>1158</b>
A214/4	677	<b>1159</b>
A214/4	677	<b>1160</b>
A214/4	678	<b>1161</b>
A214/4	678	<b>1162</b>
A214/4	679	<b>1163</b>
A214/4	680	<b>1164</b>
A214/4	680	<b>1165</b>
A214/4	683	<b>1168</b>
A214/4	683	<b>1169</b>
A214/4	684	<b>1170</b>
A214/4	685	<b>1171</b>
A221/2	472	<b>840</b>
A221/2	473	<b>841</b>
A221/2	474	<b>844</b>
A221/2	475	<b>845</b>
A221/2	476	<b>846</b>
A221/2	477	<b>847</b>
A221/2	477	<b>848</b>
A221/2	477	<b>849</b>
A221/2	491	<b>874</b>
A221/2	491	<b>875</b>
A221/2	695	<b>1185</b>
A221/2	698	<b>1189</b>
A227/2	721	<b>1227</b>
A227/2	721	<b>1228</b>
A227/2	729	<b>1245</b>
A227/2	729	<b>1246</b>
A227/2	730	<b>1248</b>
A227/2	731	<b>1249</b>
A241/2	687	<b>1175</b>
A241/2	687	<b>1176</b>
A241/2	688	<b>1177</b>
A241/2	689	<b>1178</b>
A241/2	690	<b>1179</b>
A291/2	485	<b>864</b>
A291/2	486	<b>865</b>
A291/2	486	<b>867</b>
A291/2	487	<b>869</b>
A291/2	584	<b>1019</b>
A316/2	483	<b>858</b>
A321/2	517	<b>921</b>
A321/2	518	<b>922</b>
AA5420	94	<b>190</b>
AA5420	95	<b>191</b>
AA5420	101	<b>198</b>
AA5420	102	<b>199</b>

 <b>9</b>		
AA5420	104	<b>201</b>
AA5420	104	<b>202</b>
AA5420	106	<b>204</b>
AA5420	207	<b>345</b>
AA5420	209	<b>348</b>
AA5420	211	<b>350</b>
AA5420	212	<b>351</b>
AA5520	244	<b>417</b>
AA5520	245	<b>422</b>
AA5550	328	<b>568</b>
AA5550	328	<b>569</b>
AA5561	112	<b>211</b>
AA5561	113	<b>212</b>
AA5561	114	<b>213</b>
AA5561	115	<b>214</b>
AA5561	116	<b>216</b>
AA5561	118	<b>218</b>
AA5561	119	<b>219</b>
AA5561	120	<b>220</b>
AA5561	121	<b>221</b>
AA5561	122	<b>222</b>
AA5561	128	<b>231</b>
AA5561	128	<b>232</b>
AA5561	129	<b>233</b>
AA5561	130	<b>235</b>
AA5561	131	<b>236</b>
AA5561	132	<b>237</b>
AA5561	135	<b>244</b>
AA5561	143	<b>255</b>
AA5561	144	<b>256</b>
AA5571	112	<b>211</b>
AA5571	113	<b>212</b>
AA5571	114	<b>213</b>
AA5571	115	<b>214</b>
AA5571	116	<b>216</b>
AA5571	118	<b>218</b>
AA5571	119	<b>219</b>
AA5571	120	<b>220</b>
AA5571	121	<b>221</b>
AA5571	122	<b>222</b>
AA5571	128	<b>231</b>
AA5571	128	<b>232</b>
AA5571	129	<b>233</b>
AA5571	130	<b>235</b>
AA5571	131	<b>236</b>
AA5571	132	<b>237</b>
AA5571	135	<b>244</b>
AA5571	143	<b>255</b>
AA5571	144	<b>256</b>
AA5581	112	<b>211</b>
AA5581	113	<b>212</b>
AA5581	114	<b>213</b>
AA5581	115	<b>214</b>
AA5581	116	<b>216</b>
AA5581	118	<b>218</b>
AA5581	119	<b>219</b>
AA5581	120	<b>220</b>
AA5581	121	<b>221</b>
AA5581	122	<b>222</b>
AA5581	128	<b>231</b>

			<b>9</b>
AA5581	128	<b>232</b>	
AA5581	129	<b>233</b>	
AA5581	130	<b>235</b>	
AA5581	131	<b>236</b>	
AA5581	132	<b>237</b>	
AA5581	135	<b>244</b>	
AA5581	143	<b>255</b>	
AA5581	144	<b>256</b>	
AA5590	151	<b>264</b>	
AA5590	152	<b>265</b>	
AA5590	213	<b>354</b>	
AA5720	156	<b>269</b>	
AA5720	158	<b>271</b>	
AA5730	156	<b>269</b>	
AA5730	158	<b>271</b>	
AA5740	156	<b>269</b>	
AA5740	158	<b>271</b>	
AA5780	161	<b>274</b>	
AA5780	162	<b>275</b>	
AA5780	163	<b>276</b>	
AA5780	164	<b>277</b>	
AA5790	161	<b>274</b>	
AA5790	162	<b>275</b>	
AA5790	163	<b>276</b>	
AA5790	164	<b>277</b>	
AA5800	161	<b>274</b>	
AA5800	162	<b>275</b>	
AA5800	163	<b>276</b>	
AA5800	164	<b>277</b>	
AA5830	172	<b>294</b>	
AA5840	172	<b>294</b>	
AA5850	172	<b>294</b>	
AA5860	172	<b>294</b>	
AA5870	172	<b>294</b>	
AA5880	172	<b>294</b>	
AB5101	347	<b>614</b>	
AB5101	349	<b>617</b>	
AB5101	363	<b>635</b>	
AB5101	363	<b>636</b>	
AB5101	364	<b>637</b>	
AB5101	367	<b>641</b>	
AB5101	370	<b>646</b>	
AB5101	371	<b>648</b>	
AB5101	372	<b>650</b>	
AB5101	373	<b>652</b>	
AB5101	374	<b>653</b>	
AB5101	376	<b>658</b>	
AB5101	378	<b>660</b>	
AB5101	380	<b>663</b>	
AB5101	385	<b>672</b>	
AB5101	386	<b>674</b>	
AB5101	387	<b>675</b>	
AB5111	347	<b>614</b>	
AB5111	348	<b>615</b>	
AB5111	349	<b>617</b>	
AB5111	363	<b>635</b>	
AB5111	363	<b>636</b>	
AB5111	364	<b>637</b>	
AB5111	367	<b>641</b>	
AB5111	368	<b>642</b>	

			<b>9</b>
AB5111	369	<b>645</b>	
AB5111	372	<b>650</b>	
AB5111	373	<b>652</b>	
AB5111	374	<b>653</b>	
AB5111	374	<b>654</b>	
AB5111	375	<b>655</b>	
AB5111	376	<b>658</b>	
AB5111	377	<b>659</b>	
AB5111	378	<b>660</b>	
AB5111	380	<b>663</b>	
AB5111	385	<b>672</b>	
AB5111	386	<b>674</b>	
AB5111	387	<b>675</b>	
AB5150	88	<b>180</b>	
AB5150	89	<b>181</b>	
AB5720	332	<b>580</b>	
AB5720	333	<b>581</b>	
AB5720	333	<b>582</b>	
AB5720	334	<b>583</b>	
AB5720	334	<b>585</b>	
AB5720	335	<b>586</b>	
AB5720	336	<b>588</b>	
AB5720	336	<b>589</b>	
AB5720	337	<b>591</b>	
AB5720	350	<b>618</b>	
AB5730	332	<b>580</b>	
AB5730	333	<b>581</b>	
AB5730	333	<b>582</b>	
AB5730	334	<b>583</b>	
AB5730	334	<b>585</b>	
AB5730	335	<b>586</b>	
AB5730	336	<b>588</b>	
AB5730	336	<b>589</b>	
AB5730	337	<b>591</b>	
AB5730	350	<b>618</b>	
AB5740	332	<b>580</b>	
AB5740	333	<b>581</b>	
AB5740	333	<b>582</b>	
AB5740	334	<b>583</b>	
AB5740	334	<b>585</b>	
AB5740	335	<b>586</b>	
AB5740	336	<b>588</b>	
AB5740	336	<b>589</b>	
AB5740	337	<b>591</b>	
AB5740	350	<b>618</b>	
AC5012	285	<b>494</b>	
AC5012	287	<b>497</b>	
AC5012	288	<b>498</b>	
AC5020	285	<b>494</b>	
AC5020	287	<b>497</b>	
AC5020	288	<b>498</b>	
AC5032	285	<b>494</b>	
AC5032	287	<b>497</b>	
AC5032	288	<b>498</b>	
AC5040	285	<b>494</b>	
AC5040	287	<b>497</b>	
AC5040	288	<b>498</b>	
AC5052	285	<b>494</b>	
AC5052	287	<b>497</b>	
AC5052	288	<b>498</b>	

			<b>9</b>
AC5140	173	<b>296</b>	
AC5140	174	<b>298</b>	
AC5140	176	<b>301</b>	
AC5140	177	<b>302</b>	
AC5140	178	<b>303</b>	
AC5140	180	<b>306</b>	
AC5140	183	<b>311</b>	
AC5140	185	<b>313</b>	
AC5140	187	<b>315</b>	
AC5140	189	<b>318</b>	
AC5140	190	<b>319</b>	
AC5140	196	<b>325</b>	
AC5140	197	<b>326</b>	
AC5150	173	<b>296</b>	
AC5150	174	<b>298</b>	
AC5150	176	<b>301</b>	
AC5150	177	<b>302</b>	
AC5150	178	<b>303</b>	
AC5150	180	<b>306</b>	
AC5150	183	<b>311</b>	
AC5150	184	<b>312</b>	
AC5150	185	<b>313</b>	
AC5150	187	<b>315</b>	
AC5150	189	<b>318</b>	
AC5150	190	<b>319</b>	
AC5150	196	<b>325</b>	
AC5150	197	<b>326</b>	
AC5160	173	<b>296</b>	
AC5160	174	<b>298</b>	
AC5160	176	<b>301</b>	
AC5160	177	<b>302</b>	
AC5160	178	<b>303</b>	
AC5160	180	<b>306</b>	
AC5160	183	<b>311</b>	
AC5160	184	<b>312</b>	
AC5160	185	<b>313</b>	
AC5160	187	<b>315</b>	
AC5160	189	<b>318</b>	
AC5180	173	<b>296</b>	
AC5180	174	<b>298</b>	
AC5180	176	<b>301</b>	
AC5180	177	<b>302</b>	
AC5180	178	<b>303</b>	
AC5180	180	<b>306</b>	
AC5180	183	<b>311</b>	
AC5180	184	<b>312</b>	
AC5180	185	<b>313</b>	
AC5180	187	<b>315</b>	
AC5180	189	<b>318</b>	
AC5180	190	<b>319</b>	
AC5180	196	<b>325</b>	
AC5180	197	<b>326</b>	
AD5130	47	<b>86</b>	
AD5140	47	<b>86</b>	
AD5150	47	<b>86</b>	
AD5160	47	<b>86</b>	
AD5170	47	<b>86</b>	

			<b>9</b>
AD5190	165	<b>279</b>	
AD5190	166	<b>283</b>	
AD5300	282	<b>485</b>	
AD5300	282	<b>486</b>	
AD5300	283	<b>487</b>	
AD5490	283	<b>489</b>	
AD5490	284	<b>490</b>	
AD5490	284	<b>492</b>	
AD5490	285	<b>493</b>	
AD5490	286	<b>496</b>	
AD5490	291	<b>504</b>	
AD5490	291	<b>505</b>	
AD5500	283	<b>489</b>	
AD5500	284	<b>492</b>	
AD5500	285	<b>493</b>	
AD5500	286	<b>495</b>	
AD5500	286	<b>496</b>	
AD5500	291	<b>504</b>	
AD5500	291	<b>505</b>	
AD5510	283	<b>489</b>	
AD5510	284	<b>492</b>	
AD5510	285	<b>493</b>	
AD5510	286	<b>495</b>	
AD5510	286	<b>496</b>	
AD5510	291	<b>504</b>	
AD5510	291	<b>505</b>	
AD5520	283	<b>489</b>	
AD5520	284	<b>490</b>	
AD5520	284	<b>492</b>	
AD5520	285	<b>493</b>	
AD5520	286	<b>495</b>	
AD5520	286	<b>496</b>	
AD5520	291	<b>504</b>	
AD5520	291	<b>505</b>	
AD5701	46	<b>85</b>	
AD5800	10	<b>22</b>	
AD5800	11	<b>24</b>	
AD5800	11	<b>25</b>	
AD5800	12	<b>26</b>	
AD5800	12	<b>27</b>	
AD5800	13	<b>28</b>	
AD5800	13	<b>29</b>	
AD5800	14	<b>30</b>	
AD5800	14	<b>31</b>	
AD5800	14	<b>32</b>	
AD5800	15	<b>33</b>	
AD5810	10	<b>22</b>	
AD5810	11	<b>24</b>	
AD5810	11	<b>25</b>	
AD5810	12	<b>26</b>	
AD5810	12	<b>27</b>	
AD5810	13	<b>28</b>	
AD5810	13	<b>29</b>	
AD5810	14	<b>30</b>	
AD5810	14	<b>31</b>	
AD5810	14	<b>32</b>	
AD5810	15	<b>33</b>	
AD5820	10	<b>22</b>	
AD5820	11	<b>24</b>	

# NUMERICAL PARTS LIST

Numerische Teilenummernliste • Elenco riferimenti  
 Liste des références produits

		<b>9</b>
AD5820	11	25
AD5820	12	26
AD5820	12	27
AD5820	13	28
AD5820	13	29
AD5820	14	30
AD5820	14	31
AD5820	14	32
AD5820	15	33
AD5830	28	51
AD5830	28	52
AD5830	31	57
AD5830	34	60
AD5830	35	61
AD5840	123	223
AD5840	124	224
AD5840	132	238
AD5840	133	239
AD5840	133	240
AD5840	134	241
AD5840	134	242
AD5840	136	245
AD5840	138	248
AD5840	139	249
AD5840	140	251
AD5840	140	252
AD5850	123	223
AD5850	124	224
AD5850	132	238
AD5850	133	239
AD5850	133	240
AD5850	134	241
AD5850	134	242
AD5850	136	245
AD5850	138	248
AD5850	139	249
AD5850	140	251
AD5850	140	252
AD5860	123	223
AD5860	124	224
AD5860	132	238
AD5860	133	239
AD5860	133	240
AD5860	134	241
AD5860	134	242
AD5860	136	245
AD5860	138	248
AD5860	139	249
AD5860	140	251
AD5860	140	252
AD5870	206	343
AD5870	206	344
AD5910	164	278
AD5910	165	281
AD5910	166	282
AD5920	164	278
AD5920	165	279
AD5920	165	281
AD5920	166	282
AD5920	166	283

		<b>9</b>
AD5930	164	278
AD5930	165	279
AD5930	165	281
AD5930	166	282
AD5930	166	283
AD5950	207	345
AD5950	209	348
AD5960	155	268
AD5960	216	357
AD5970	88	180
AD5970	89	181
AE5240	24	47
AE5240	25	48
AE5240	26	49
AE5240	27	50
AE5240	29	53
AE5240	29	54
AE5240	30	55
AE5240	32	58
AE5240	33	59
AE5240	36	62
AE5240	37	63
AE5550	24	47
AE5550	25	48
AE5550	26	49
AE5550	27	50
AE5550	29	53
AE5550	29	54
AE5550	30	55
AE5550	30	56
AE5550	32	58
AE5550	33	59
AE5550	37	63
AE5550	38	64
AF240	46	84
AF370	57	108
AF370	57	110
AG6050	422	743
AG6050	423	746
AG6050	423	747
AG6060	174	299
AG6060	422	743
AG6060	423	746
AG6060	423	747
AG6220	38	65
AG6220	39	66
AG6220	39	67
AG6220	41	71
AG6220	44	77
AG7300	174	299
AG7300	422	743
AG7300	423	746
AG7300	423	747
AG7310	34	60
AG7310	39	66
AG7310	39	67
AG7310	41	72
AG7310	42	73
AG7310	44	77
AG7310	45	81

		<b>9</b>
AG7310	45	82
AG7380	23	45
AG7380	23	46
AG7380	36	62
AG7380	42	74
AG7380	43	76
AG7390	115	215
AG7390	116	216
AG7390	118	218
AG7390	119	219
AG7390	120	220
AG7390	121	221
AG7390	122	222
AG7390	124	225
AG7390	125	226
AG7390	125	227
AG7390	126	228
AG7390	126	229
AG7390	128	231
AG7390	128	232
AG7390	129	233
AG7390	135	243
AG7390	135	244
AG7390	136	246
AG7390	137	247
AG7390	139	250
AG7390	145	257
AG7400	115	215
AG7400	116	216
AG7400	118	218
AG7400	119	219
AG7400	120	220
AG7400	121	221
AG7400	122	222
AG7400	124	225
AG7400	125	226
AG7400	125	227
AG7400	126	228
AG7400	126	229
AG7400	128	231
AG7400	128	232
AG7400	129	233
AG7400	135	243
AG7400	135	244
AG7400	136	246
AG7400	137	247
AG7400	139	250
AG7400	145	257
AG7400	166	284
AG7400	167	285
AG7400	167	286
AG7400	168	287
AG7400	168	288
AG7400	168	289
AG7400	168	290
AG7400	168	291
AG7400	168	292
AG7400	168	293
AG7400	168	294
AG7400	168	295
AG7400	168	296
AG7400	168	297
AG7400	168	298
AG7400	168	299
AG7400	168	300
AG7400	168	301
AG7400	168	302
AG7400	168	303
AG7400	168	304
AG7400	168	305
AG7400	168	306
AG7400	168	307
AG7400	168	308
AG7400	168	309
AG7400	168	310
AG7400	168	311
AG7400	168	312
AG7400	168	313
AG7400	168	314
AG7400	168	315
AG7400	168	316
AG7400	168	317
AG7400	168	318
AG7400	168	319
AG7400	168	320
AG7400	168	321
AG7400	168	322
AG7400	168	323
AG7400	168	324
AG7400	168	325
AG7400	168	326
AG7400	168	327
AG7400	168	328
AG7400	168	329
AG7400	168	330
AG7400	168	331
AG7400	168	332
AG7400	168	333
AG7400	168	334
AG7400	168	335
AG7400	168	336
AG7400	168	337
AG7400	168	338
AG7400	168	339
AG7400	168	340
AG7400	168	341
AG7400	168	342
AG7400	168	343
AG7400	168	344
AG7400	168	345
AG7400	168	346
AG7400	168	347
AG7400	168	348
AG7400	168	349
AG7400	168	350
AG7400	168	351
AG7400	168	352
AG7400	168	353
AG7400	168	354
AG7400	168	355
AG7400	168	356
AG7400	168	357
AG7400	168	358
AG7400	168	359
AG7400	168	360
AG7400	168	361
AG7400	168	362
AG7400	168	363
AG7400	168	364
AG7400	168	365
AG7400	168	366
AG7400	168	367
AG7400	168	368
AG7400	168	369
AG7400	168	370
AG7400	168	371
AG7400	168	372
AG7400	168	373
AG7400	168	374
AG7400	168	375
AG7400	168	376
AG7400	168	377
AG7400	168	378
AG7400	168	379
AG7400	168	380
AG7400	168	381
AG7400	168	382
AG7400	168	383
AG7400	168	384
AG7400	168	385
AG7400	168	386
AG7400	168	387
AG7400	168	388
AG7400	168	389
AG7400	168	390
AG7400	168	391
AG7400	168	392
AG7400	168	393
AG7400	168	394
AG7400	168	395
AG7400	168	396
AG7400	168	397
AG7400	168	398
AG7400	168	399
AG7400	168	400
AG7400	168	401
AG7400	168	402
AG7400	168	403
AG7400	168	404
AG7400	168	405
AG7400	168	406
AG7400	168	407
AG7400	168	408
AG7400	168	409
AG7400	168	410
AG7400	168	411
AG7400	168	412
AG7400	168	413
AG7400	168	414
AG7400	168	415
AG7400	168	416
AG7400	168	417
AG7400	168	418
AG7400	168	419
AG7400	168	420
AG7400	168	421
AG7400	168	422
AG7400	168	423
AG7400	168	424
AG7400	168	425
AG7400	168	426
AG7400	168	427
AG7400	168	428
AG7400	168	429
AG7400	168	430
AG7400	168	431
AG7400	168	432
AG7400	168	433
AG7400	168	434
AG7400	168	435
AG7400	168	436
AG7400	168	437
AG7400	168	438
AG7400	168	439
AG7400	168	440
AG7400	168	441
AG7400	168	442
AG7400	168	443
AG7400	168	444
AG7400	168	445
AG7400	168	446
AG7400	168	447
AG7400	168	448
AG7400	168	449
AG7400	168	450
AG7400	168	451
AG7400	168	452
AG7400	168	453
AG7400	168	454
AG7400	168	455
AG7400	168	456
AG7400	168	457
AG7400	168	458
AG7400	168	459
AG7400	168	460
AG7400	168	461
AG7400	168	462
AG7400	168	463
AG7400	168	464
AG7400	168	465
AG7400	168	466
AG7400	168	467
AG7400	168	468
AG7400	168	469
AG7400	168	470
AG7400	168	471
AG7400	168	472
AG7400	168	473
AG7400	168	474
AG7400	168	475
AG7400	168	476
AG7400	168	477
AG7400	168	478
AG7400	168	479
AG7400	168	480
AG7400	168	481
AG7400	168	482
AG7400	168	483
AG7400	168	484
AG7400	168	485
AG7400	168	486
AG7400	168	487
AG7400	168	488
AG7400	168	489
AG7400	168	490
AG7400	168	491
AG7400	168	492
AG7400	168	493
AG7400	168	494
AG7400	168	495
AG7400	168	496
AG7400	168	497
AG7400	168	498
AG7400	168	499
AG7400	168	500
AG7400	168	501
AG7400	168	502
AG7400	168	503
AG7400	168	504
AG7400	168	505

			<b>9</b>
AH7380	205	<b>340</b>	
AH7380	205	<b>341</b>	
AH7390	205	<b>340</b>	
AH7390	205	<b>341</b>	
AM870	10	<b>21</b>	
AN300	243	<b>414</b>	
AN300	244	<b>415</b>	
AN300	244	<b>416</b>	
AN300	244	<b>419</b>	
AN300	245	<b>420</b>	
AN300	245	<b>421</b>	
AN300	246	<b>424</b>	
AN300	246	<b>425</b>	
AN300	342	<b>606</b>	
AN350	68	<b>132</b>	
AN350	69	<b>137</b>	
AN350	70	<b>138</b>	
AN350	71	<b>140</b>	
AY070	295	<b>512</b>	
AY290	353	<b>621</b>	
AY290	381	<b>666</b>	
AY290	382	<b>667</b>	
AY290	383	<b>668</b>	
AY290	384	<b>670</b>	
AY290	388	<b>676</b>	
AY290	389	<b>677</b>	
AY290	390	<b>679</b>	
AY290	391	<b>680</b>	
AY290	392	<b>681</b>	
AY290	393	<b>682</b>	
AY290	394	<b>683</b>	
AY290	394	<b>684</b>	
AY300	353	<b>621</b>	
AY300	379	<b>662</b>	
AY300	380	<b>663</b>	
AY300	381	<b>666</b>	
AY300	382	<b>667</b>	
AY300	383	<b>668</b>	
AY300	384	<b>670</b>	
AY300	388	<b>676</b>	
AY300	389	<b>677</b>	
AY300	390	<b>679</b>	
AY300	391	<b>680</b>	
AY300	392	<b>681</b>	
AY300	393	<b>682</b>	
AY300	394	<b>683</b>	
AY300	394	<b>684</b>	
AY310	353	<b>621</b>	
AY310	381	<b>666</b>	
AY310	382	<b>667</b>	
AY310	383	<b>668</b>	
AY310	384	<b>670</b>	
AY310	388	<b>676</b>	
AY310	389	<b>677</b>	
AY310	390	<b>679</b>	
AY310	391	<b>680</b>	
AY310	392	<b>681</b>	
AY310	393	<b>682</b>	
AY310	394	<b>683</b>	
AY310	394	<b>684</b>	

			<b>9</b>
AY320	146	<b>258</b>	
AY320	147	<b>259</b>	
AY400	331	<b>578</b>	
AY400	332	<b>579</b>	
AY400	342	<b>606</b>	
AY400	342	<b>607</b>	
AY400	343	<b>608</b>	
AY400	343	<b>609</b>	
AY400	344	<b>611</b>	
AY410	331	<b>578</b>	
AY410	332	<b>579</b>	
AY410	342	<b>606</b>	
AY410	342	<b>607</b>	
AY410	343	<b>608</b>	
AY410	343	<b>609</b>	
AY410	344	<b>611</b>	
AY420	331	<b>578</b>	
AY420	332	<b>579</b>	
AY420	342	<b>606</b>	
AY420	342	<b>607</b>	
AY420	343	<b>608</b>	
AY420	343	<b>609</b>	
AY420	343	<b>609</b>	
AY420	344	<b>610</b>	
AY420	344	<b>611</b>	
AY430	4	<b>5</b>	
AY430	7	<b>14</b>	
AY430	8	<b>15</b>	
AY460	311	<b>540</b>	
AY460	312	<b>541</b>	
AY460	312	<b>542</b>	
AY460	313	<b>543</b>	
AY460	314	<b>545</b>	
AY460	314	<b>546</b>	
AY460	315	<b>547</b>	
AY460	321	<b>558</b>	
AY460	322	<b>559</b>	
AY460	323	<b>560</b>	
AY460	324	<b>561</b>	
AY460	325	<b>562</b>	
AY470	315	<b>548</b>	
AY470	316	<b>549</b>	
AY470	316	<b>550</b>	
AY470	317	<b>551</b>	
AY470	317	<b>552</b>	
AY470	318	<b>553</b>	
AY470	318	<b>554</b>	
AY470	319	<b>555</b>	
AY470	319	<b>556</b>	
AY470	320	<b>557</b>	
AY480	90	<b>184</b>	
AY480	91	<b>185</b>	
AY480	91	<b>186</b>	
AY500	93	<b>189</b>	
AY500	95	<b>192</b>	
AY500	96	<b>193</b>	
AY500	97	<b>194</b>	
AY500	98	<b>195</b>	
AY500	99	<b>196</b>	
AY500	100	<b>197</b>	
AY500	103	<b>200</b>	

			<b>9</b>
AY500	104	<b>201</b>	
AY500	104	<b>202</b>	
AY500	105	<b>203</b>	
AY500	107	<b>205</b>	
AY500	108	<b>206</b>	
AY500	241	<b>408</b>	
AY510	92	<b>187</b>	
AY520	111	<b>210</b>	
AY520	141	<b>253</b>	
AY520	142	<b>254</b>	
AY530	111	<b>210</b>	
AY530	141	<b>253</b>	
AY530	142	<b>254</b>	
AY540	111	<b>210</b>	
AY540	141	<b>253</b>	
AY540	142	<b>254</b>	
AY550	157	<b>270</b>	
AY550	159	<b>272</b>	
AY550	160	<b>273</b>	
AY550	169	<b>289</b>	
AY550	170	<b>290</b>	
AY560	157	<b>270</b>	
AY560	159	<b>272</b>	
AY560	160	<b>273</b>	
AY560	169	<b>289</b>	
AY560	170	<b>290</b>	
AY570	157	<b>270</b>	
AY570	159	<b>272</b>	
AY570	160	<b>273</b>	
AY570	170	<b>290</b>	
AY581	347	<b>614</b>	
AY581	349	<b>617</b>	
AY581	363	<b>635</b>	
AY581	363	<b>636</b>	
AY581	364	<b>637</b>	
AY581	367	<b>641</b>	
AY581	370	<b>647</b>	
AY581	372	<b>650</b>	
AY581	373	<b>652</b>	
AY581	374	<b>653</b>	
AY581	376	<b>658</b>	
AY581	378	<b>660</b>	
AY581	380	<b>663</b>	
AY581	385	<b>672</b>	
AY581	386	<b>674</b>	
AY581	387	<b>675</b>	
AY591	347	<b>614</b>	
AY591	348	<b>616</b>	
AY591	349	<b>617</b>	
AY591	363	<b>635</b>	
AY591	363	<b>636</b>	
AY591	364	<b>637</b>	
AY591	364	<b>638</b>	
AY591	367	<b>641</b>	
AY591	368	<b>642</b>	
AY591	368	<b>643</b>	
AY591	369	<b>645</b>	
AY591	370	<b>647</b>	
AY591	371	<b>649</b>	
AY591	372	<b>650</b>	

			<b>9</b>
AY591	372	<b>651</b>	
AY591	373	<b>652</b>	
AY591	374	<b>653</b>	
AY591	374	<b>654</b>	
AY591	375	<b>656</b>	
AY591	376	<b>658</b>	
AY591	378	<b>660</b>	
AY591	379	<b>661</b>	
AY591	380	<b>663</b>	
AY591	384	<b>671</b>	
AY591	385	<b>672</b>	
AY591	386	<b>674</b>	
AY591	387	<b>675</b>	
AY591	389	<b>678</b>	
AY610	78	<b>160</b>	
AY620	338	<b>597</b>	
AY631	338	<b>597</b>	
AY641	339	<b>598</b>	
AY641	339	<b>599</b>	
AY641	395	<b>687</b>	
AY641	398	<b>692</b>	
AY641	398	<b>693</b>	
AY641	399	<b>694</b>	
AY641	400	<b>696</b>	
AY641	403	<b>703</b>	
AY641	404	<b>707</b>	
AY641	404	<b>708</b>	
AY641	405	<b>709</b>	
AY680	417	<b>733</b>	
AY680	418	<b>734</b>	
AY680	420	<b>737</b>	
AY690	417	<b>733</b>	
AY690	418	<b>734</b>	
AY690	420	<b>737</b>	
AY700	417	<b>733</b>	
AY700	418	<b>734</b>	
AY700	420	<b>737</b>	
BC370	56	<b>107</b>	
BC370	58	<b>112</b>	
BD790	54	<b>102</b>	
BD800	46	<b>83</b>	
BE440	109	<b>208</b>	
BE440	110	<b>209</b>	
BE450	109	<b>208</b>	
BE450	110	<b>209</b>	
BE460	109	<b>208</b>	
BE460	110	<b>209</b>	
BE580	345	<b>612</b>	
BE580	351	<b>619</b>	
BE580	352	<b>620</b>	
BE580	353	<b>621</b>	
BE580	354	<b>622</b>	
BE580	354	<b>623</b>	
BE580	358	<b>628</b>	
BE580	359	<b>630</b>	
BE580	360	<b>632</b>	
BE620	217	<b>360</b>	
BE620	218	<b>361</b>	
BE620	219	<b>363</b>	
BE620	219	<b>364</b>	

# NUMERICAL PARTS LIST

Nummerische Teilenummernliste • Elenco riferimenti  
Liste des références produits

 <b>9</b>		
BE620	220	<b>365</b>
BE620	221	<b>367</b>
BE620	222	<b>369</b>
BE620	222	<b>370</b>
BE620	232	<b>393</b>
BG820	197	<b>327</b>
BG820	198	<b>328</b>
BG830	197	<b>327</b>
BG830	198	<b>328</b>
BH850	75	<b>154</b>
BH850	75	<b>155</b>
BH850	76	<b>157</b>
BH850	76	<b>158</b>
BJ850	62	<b>121</b>
BJ850	62	<b>122</b>
BJ850	63	<b>123</b>
BJ850	64	<b>124</b>
BJ850	65	<b>125</b>
BJ860	50	<b>94</b>
BJ860	51	<b>95</b>
BJ860	52	<b>96</b>
BJ870	50	<b>94</b>
BJ870	51	<b>95</b>
BJ870	52	<b>96</b>
BJ880	50	<b>94</b>
BJ880	51	<b>95</b>
BJ880	52	<b>96</b>
BK540	73	<b>149</b>
BK540	223	<b>373</b>
BK540	224	<b>374</b>
BK540	225	<b>376</b>
BK540	225	<b>377</b>
BK540	226	<b>378</b>
BK540	226	<b>379</b>
BK540	247	<b>427</b>
BK540	247	<b>428</b>
BK540	248	<b>431</b>
BK540	257	<b>446</b>
BK570	331	<b>578</b>
BK570	332	<b>579</b>
BK570	341	<b>604</b>
BK570	341	<b>605</b>
BK570	342	<b>607</b>
BK570	344	<b>611</b>
BK580	331	<b>578</b>
BK580	332	<b>579</b>
BK580	341	<b>604</b>
BK580	341	<b>605</b>
BK580	342	<b>607</b>
BK580	344	<b>611</b>
BL650	199	<b>330</b>
BM530	330	<b>574</b>
BM530	330	<b>575</b>
BM530	331	<b>576</b>
BP030	2	<b>1</b>
BP030	5	<b>8</b>
BP030	6	<b>10</b>
BP030	6	<b>11</b>
BP030	7	<b>13</b>
BP030	55	<b>103</b>

 <b>9</b>		
BP050	55	<b>103</b>
BP060	47	<b>88</b>
BP070	60	<b>118</b>
BP070	61	<b>119</b>
BP110	292	<b>506</b>
BP110	292	<b>507</b>
BP110	298	<b>519</b>
BP110	298	<b>520</b>
BP110	301	<b>523</b>
BP110	301	<b>524</b>
BP110	303	<b>527</b>
BP110	303	<b>528</b>
BP110	306	<b>532</b>
BP130	223	<b>372</b>
BP130	232	<b>394</b>
BP130	233	<b>396</b>
BP190	223	<b>371</b>
BP190	224	<b>375</b>
BP190	247	<b>429</b>
BP190	279	<b>479</b>
BP260	331	<b>578</b>
BP260	332	<b>579</b>
BP260	341	<b>604</b>
BP260	341	<b>605</b>
BP260	342	<b>606</b>
BP260	342	<b>607</b>
BP260	343	<b>608</b>
BP260	344	<b>610</b>
BP260	344	<b>611</b>
BP280	15	<b>35</b>
BP280	16	<b>36</b>
BP280	17	<b>37</b>
BP280	18	<b>38</b>
BP280	19	<b>39</b>
BP280	20	<b>40</b>
BP280	21	<b>41</b>
BP280	22	<b>43</b>
BP280	22	<b>44</b>
BP280	66	<b>128</b>
BP290	49	<b>91</b>
BP290	49	<b>93</b>
BP290	54	<b>101</b>
BP290	65	<b>125</b>
BP290	65	<b>126</b>
BP290	66	<b>127</b>
BP290	299	<b>521</b>
BP300	81	<b>166</b>
BP300	81	<b>167</b>
BP500	9	<b>20</b>
BP510	9	<b>20</b>
BP520	2	<b>1</b>
BP520	3	<b>4</b>
BP520	5	<b>8</b>
BP520	6	<b>10</b>
BP520	6	<b>11</b>
BP520	7	<b>13</b>
BP520	8	<b>16</b>
BP520	9	<b>17</b>
BP660	2	<b>2</b>
BP660	3	<b>3</b>

 <b>9</b>		
BP860	300	<b>522</b>
BP860	302	<b>526</b>
BP860	304	<b>529</b>
BP860	305	<b>530</b>
BP860	307	<b>533</b>
BP860	308	<b>534</b>
BP860	309	<b>535</b>
BP860	310	<b>538</b>
BP860	311	<b>539</b>
BP990	325	<b>563</b>
BP990	326	<b>564</b>
BP990	326	<b>565</b>
BP990	327	<b>566</b>
BP990	327	<b>567</b>
BR071	348	<b>615</b>
BR071	355	<b>624</b>
BR071	356	<b>625</b>
BR071	357	<b>626</b>
BR090	361	<b>633</b>
BR090	362	<b>634</b>
BR510	199	<b>330</b>
BR620	84	<b>172</b>
BR620	85	<b>173</b>
BR620	85	<b>174</b>
BR620	86	<b>176</b>
BR620	87	<b>177</b>
BR620	87	<b>178</b>
BR620	239	<b>405</b>
BR620	242	<b>410</b>
BR630	312	<b>542</b>
BR630	313	<b>543</b>
BR630	314	<b>545</b>
BR630	314	<b>546</b>
BR630	315	<b>547</b>
BR630	321	<b>558</b>
BR630	322	<b>559</b>
BR630	325	<b>562</b>
BR680	175	<b>300</b>
BR680	177	<b>302</b>
BR680	178	<b>303</b>
BR680	181	<b>307</b>
BR680	183	<b>311</b>
BR680	184	<b>312</b>
BR680	188	<b>316</b>
BR680	189	<b>318</b>
BR680	190	<b>319</b>
BR680	191	<b>320</b>
BR680	192	<b>321</b>
BR680	193	<b>322</b>
BR680	194	<b>323</b>
BR680	195	<b>324</b>
BR700	179	<b>305</b>
BR700	188	<b>316</b>
BR700	189	<b>318</b>
BR700	191	<b>320</b>
BR700	192	<b>321</b>
BR700	193	<b>322</b>
BR700	194	<b>323</b>
BR700	195	<b>324</b>

 <b>9</b>		
BT230	173	<b>296</b>
BT230	173	<b>297</b>
BT230	174	<b>298</b>
BT230	174	<b>299</b>
BT230	176	<b>301</b>
BT230	179	<b>304</b>
BT230	181	<b>308</b>
BT230	185	<b>313</b>
BT240	173	<b>296</b>
BT240	173	<b>297</b>
BT240	174	<b>298</b>
BT240	174	<b>299</b>
BT240	176	<b>301</b>
BT240	179	<b>304</b>
BT240	181	<b>308</b>
BT240	185	<b>313</b>
BT240	275	<b>472</b>
BT260	4	<b>5</b>
BT260	4	<b>6</b>
BT260	7	<b>14</b>
BT260	8	<b>15</b>
BT300	182	<b>310</b>
BT320	182	<b>310</b>
BT340	328	<b>568</b>
BT340	328	<b>569</b>
BT381	339	<b>598</b>
BT381	339	<b>599</b>
BT381	395	<b>687</b>
BT381	398	<b>692</b>
BT381	398	<b>693</b>
BT381	399	<b>694</b>
BT381	400	<b>696</b>
BT381	401	<b>700</b>
BT381	403	<b>703</b>
BT381	403	<b>704</b>
BT381	404	<b>707</b>
BT381	404	<b>708</b>
BT381	405	<b>709</b>
BT390	401	<b>700</b>
BT401	82	<b>168</b>
BT401	82	<b>169</b>
BT401	83	<b>171</b>
BT401	86	<b>175</b>
BT410	228	<b>382</b>
BT410	237	<b>402</b>
BT410	240	<b>407</b>
BT410	251	<b>436</b>
BT410	255	<b>442</b>
BT410	259	<b>448</b>
BT410	262	<b>453</b>
BT410	264	<b>455</b>
BT410	269	<b>462</b>
BT420	230	<b>388</b>
BT420	232	<b>392</b>
BT420	237	<b>402</b>
BT420	240	<b>406</b>
BT420	251	<b>435</b>
BT420	251	<b>436</b>
BT420	252	<b>437</b>
BT420	253	<b>438</b>



		<b>9</b>
BT420	260	450
BT420	262	453
BT420	264	455
BT420	266	457
BT420	270	464
BT420	274	471
BT420	280	480
BT440	229	386
BT440	234	398
BT440	235	399
BT440	236	400
BT440	238	403
BT440	239	404
BT440	241	408
BT440	241	409
BT440	254	439
BT440	254	440
BT440	255	441
BT440	256	443
BT440	258	447
BT440	261	452
BT440	268	460
BT440	269	462
BT440	271	465
BT440	272	467
BT440	273	468
BT440	273	469
BT440	274	470
BT440	275	473
BT440	276	474
BT440	277	475
BT440	278	476
BT440	279	478
BT440	280	480
BT440	281	482
BT440	296	514
BT510	250	434
BT510	253	438
BT520	250	434
BT520	253	438
BT860	80	164
BT860	80	165
BV140	294	510
BV140	294	511
BV140	295	512
BV140	295	513
BV670	24	47
BV670	25	48
BV670	26	49
BV670	27	50
BV670	29	53
BV670	29	54
BV670	30	55
BV670	30	56
BV670	32	58
BV670	33	59
BV670	37	63
BV670	38	64
BV680	175	300
BV680	177	302

		<b>9</b>
BV680	178	303
BV680	180	306
BV680	181	307
BV680	183	311
BV680	184	312
BV680	186	314
BV680	187	315
BV680	188	317
BV680	189	318
BV680	190	319
BV680	191	320
BV680	193	322
BV680	196	325
BV680	197	326
BV690	175	300
BV690	177	302
BV690	178	303
BV690	180	306
BV690	181	307
BV690	183	311
BV690	184	312
BV690	186	314
BV690	187	315
BV690	188	317
BV690	189	318
BV690	190	319
BV690	191	320
BV690	196	325
BV690	197	326
BV700	175	300
BV700	177	302
BV700	178	303
BV700	180	306
BV700	181	307
BV700	183	311
BV700	184	312
BV700	186	314
BV700	187	315
BV700	188	317
BV700	189	318
BV700	190	319
BV700	191	320
BV700	196	325
BV700	197	326
BV940	15	35
BV940	16	36
BV940	17	37
BV940	18	38
BV940	19	39
BV940	20	40
BV940	21	41
BV940	22	43
BV940	22	44
BV940	66	128
BW290	77	159
BW290	78	161
BW290	79	162
BW290	79	163
BW321	148	260
BW321	149	261

		<b>9</b>
BW321	150	262
BW321	151	263
BW321	153	266
BW321	154	267
BW321	215	356
BW330	214	355
BW340	156	269
BW340	158	271
BW350	156	269
BW350	158	271
BW360	156	269
BW360	158	271
BW410	213	353
BW410	216	358
BW410	217	359
BW410	243	412
BW410	280	481
BW710	208	346
BW710	208	347
BW710	210	349
BW710	212	352
BW720	93	189
BW720	94	190
BW720	95	192
BW720	96	193
BW720	97	194
BW720	98	195
BW720	99	196
BW720	100	197
BW720	103	200
BW720	104	201
BW720	104	202
BW720	105	203
BW720	107	205
BW720	108	206
BW980	175	300
BW980	177	302
BW980	178	303
BW980	180	306
BW980	181	307
BW980	183	311
BW980	184	312
BW980	186	314
BW980	187	315
BW980	190	319
BW980	191	320
BW980	196	325
BW980	197	326
BX030	315	548
BX030	316	549
BX030	316	550
BX030	317	551
BX030	317	552
BX030	318	553
BX030	318	554
BX030	319	555
BX030	319	556
BX030	320	557
BX040	90	184
BX040	91	185

		<b>9</b>
BX040	91	186
BX391	406	711
BX391	413	724
BX391	414	726
BX391	415	727
BX391	416	730
BX391	416	731
BX391	417	732
BX391	419	736
BX401	405	710
BX401	406	711
BX401	409	715
BX401	410	717
BX401	411	719
BX401	411	720
BX401	413	724
BX401	414	725
BX401	414	726
BX401	415	727
BX401	415	728
BX401	416	730
BX401	416	731
BX401	417	732
BX401	419	736
BX411	405	710
BX411	406	711
BX411	408	713
BX411	409	715
BX411	410	717
BX411	411	720
BX411	413	723
BX411	413	724
BX411	414	725
BX411	414	726
BX411	415	727
BX411	415	728
BX411	415	729
BX411	416	730
BX411	416	731
BX411	417	732
BX411	419	736
BX421	405	710
BX421	406	711
BX421	409	715
BX421	410	717
BX421	411	720
BX421	412	721
BX421	412	722
BX421	413	724
BX421	414	725
BX421	414	726
BX421	415	727
BX421	415	728
BX421	416	730
BX421	416	731
BX421	417	732
BX421	419	736
BX880	201	333
BX880	202	334
BX880	204	339

# NUMERICAL PARTS LIST

Numerische Teilenummernliste • Elenco riferimenti  
Liste des références produits

		 <b>9</b>
BX890	201	333
BX890	202	334
BX890	204	339
BX900	201	333
BX900	202	334
BX900	204	339
BX910	201	333
BX910	202	334
BX910	204	339
BX920	201	333
BX920	202	334
BX920	204	339
BX930	200	331
BX930	200	332
BX930	202	335
BX930	203	336
BX930	203	337
BX940	200	331
BX940	200	332
BX940	202	335
BX940	203	336
BX940	203	337
BX950	200	331
BX950	200	332
BX950	202	335
BX950	203	336
BX950	203	337
BX960	200	331
BX960	200	332
BX960	202	335
BX960	203	336
BX960	203	337
BX970	200	331
BX970	200	332
BX970	202	335
BX970	203	336
BX970	203	337
BX980	200	331
BX980	200	332
BX980	202	335
BX980	203	336
BX980	203	337
BY310	296	514
BY310	296	515
BY320	293	509
BY320	294	510
BY320	295	513
BY320	296	514
BY380	28	51
BY380	28	52
BY380	31	57
BY380	34	60
BY380	35	61
BY390	92	187
BY410	109	208
BY410	110	209
BY420	109	208
BY420	110	209
BY430	109	208
BY430	110	209

		 <b>9</b>
BY942	288	499
BY942	289	500
BY950	288	499
BY950	289	500
BY962	288	499
BY962	289	500
BY970	288	499
BY970	289	500
BY982	288	499
BY982	289	500
BZ791	117	217
BZ791	127	230
BZ801	117	217
BZ801	127	230
BZ811	117	217
BZ811	127	230
CA5420	94	190
CA5420	95	191
CA5420	106	204
CA5420	209	348
CA5420	211	350
CA5420	212	351
CA5421	101	198
CA5421	102	199
CA5421	104	201
CA5421	104	202
CA5560	112	211
CA5560	113	212
CA5560	114	213
CA5560	115	214
CA5560	116	216
CA5560	118	218
CA5560	119	219
CA5560	120	220
CA5560	121	221
CA5560	122	222
CA5560	125	226
CA5560	128	231
CA5560	128	232
CA5560	129	233
CA5560	130	235
CA5560	131	236
CA5560	132	237
CA5560	135	244
CA5560	143	255
CA5560	144	256
CA5561	112	211
CA5561	113	212
CA5561	114	213
CA5561	115	214
CA5561	115	215
CA5561	116	216
CA5561	118	218
CA5561	119	219
CA5561	120	220
CA5561	121	221
CA5561	122	222
CA5561	124	225
CA5561	125	226
CA5561	128	231

		 <b>9</b>
CA5561	128	232
CA5561	129	233
CA5561	130	235
CA5561	131	236
CA5561	132	237
CA5561	135	244
CA5561	143	255
CA5561	144	256
CA5590	151	264
CA5590	152	265
CA5590	213	354
CA5780	161	274
CA5780	162	275
CA5780	163	276
CA5780	164	277
CA5830	172	294
CAM354	201	333
CAM354	204	339
CAM373	201	333
CAM373	204	339
CAM391	51	95
CAM391	52	96
CAM417	178	303
CAM417	179	304
CAM517	60	118
CAM517	292	506
CAM517	298	519
CAM517	298	520
CAM517	303	527
CAM517	303	528
CAM517	304	529
CAM517	305	530
CAM641	176	301
CAM648	90	184
CAM648	91	185
CAM648	91	186
CAM649	109	208
CAM649	110	209
CAM651	111	210
CAM651	114	213
CAM651	115	214
CAM651	141	253
CAM651	142	254
CAM652	157	270
CAM652	158	271
CAM652	159	272
CAM652	160	273
CAM652	161	274
CAM652	162	275
CAM652	169	289
CAM653	116	216
CAM653	117	217
CAM653	118	218
CAM653	126	228
CAM653	127	230
CAM654	112	211
CAM654	113	212
CAM654	115	215
CAM654	119	219
CAM654	120	220

		 <b>9</b>
CAM654	121	221
CAM654	122	222
CAM654	124	225
CAM654	125	226
CAM654	126	229
CAM654	128	231
CAM654	130	235
CAM654	131	236
CAM654	135	243
CAM654	136	246
CAM654	137	247
CAM654	139	250
CAM654	143	255
CAM654	144	256
CAM654	145	257
CAM679	285	494
CAM679	287	497
CAM681	383	668
CAM681	385	672
CAM681	416	731
CAM681	419	736
CAM709	315	548
CAM709	317	551
CAM709	319	555
CAM709	319	556
CAM709	320	557
CAM710	315	548
CAM710	317	551
CAM710	319	555
CAM710	319	556
CAM710	320	557
CAM711	10	22
CAM711	12	26
CAM711	13	28
CAM711	13	29
CAM711	15	33
CAM712	10	22
CAM712	12	26
CAM712	13	28
CAM712	13	29
CAM712	15	33
CAM713	34	60
CAM713	35	61
CAM714	34	60
CAM714	35	61
CAM716	89	181
CAM717	89	181
CAM718	388	676
CAM718	390	679
CAM718	418	734
CAM718	420	737
CAM719	84	172
CAM719	86	176
CAM719	313	543
CAM719	324	561
CAM719	325	562
CAM750	284	490
CAM750	286	495
CAM750	286	496
CAM750	290	503

		<b>9</b>
CAM750	291	504
CAM750	291	505
CAM751	284	490
CAM751	286	495
CAM751	286	496
CAM751	290	503
CAM751	291	504
CAM751	291	505
CB5150	88	180
CB5150	89	181
CB5720	332	580
CB5720	333	581
CB5720	333	582
CB5720	334	583
CB5720	334	585
CB5720	335	587
CB5720	336	588
CB5720	336	589
CB5720	336	590
CB5720	337	591
CB5720	350	618
CC5010	284	490
CC5010	285	494
CC5010	287	497
CC5010	288	498
CD5140	47	86
CD5300	282	485
CD5490	284	490
CD5490	286	495
CD5490	291	504
CD5490	291	505
CD5500	283	489
CD5500	284	492
CD5500	285	493
CD5810	10	22
CD5810	11	25
CD5810	12	26
CD5810	14	30
CD5820	12	27
CD5820	13	28
CD5820	13	29
CD5820	14	31
CD5820	14	32
CD5820	15	33
CD5840	123	223
CD5840	124	224
CD5840	132	238
CD5840	133	239
CD5840	133	240
CD5840	134	241
CD5840	134	242
CD5840	136	245
CD5910	164	278
CD5910	165	279
CD5910	165	281
CD5910	166	282
CD5910	166	283
CD5960	155	268
CD5970	88	180
CD5970	89	181

		<b>9</b>
CE5180	28	51
CE5180	28	52
CE5180	31	57
CE5181	34	60
CE5181	35	61
CE5241	32	58
CE5241	33	59
CE5241	37	63
CE5242	30	55
CE5242	32	58
CE5242	33	59
CE5242	36	62
CF24N	57	108
CF24N	57	109
CG01A	5	8
CG01A	6	10
CG01A	6	11
CG01A	7	12
CG01A	7	13
CG6220	38	65
CG6220	39	66
CG6220	39	67
CG6220	44	77
CG7300	421	742
CG7300	422	743
CG7300	423	746
CG7300	423	747
CG7310	34	60
CG7310	39	66
CG7310	39	67
CG7310	44	77
CG7380	23	45
CG7380	23	46
CG7380	42	74
CG7380	43	76
CG7381	33	59
CG7381	37	63
CG7390	121	221
CG7390	122	222
CG7390	124	225
CG7390	125	227
CG7390	126	228
CG7390	126	229
CG7390	135	243
CG7390	135	244
CG7390	136	246
CG7390	137	247
CG7390	139	250
CG7390	145	257
CG7410	140	251
CG7410	140	252
CG7410	167	285
CG7410	167	286
CG7410	168	287
CG7410	168	288
CG7490	115	215
CH5040	329	571
CH5040	329	572
CH5060	329	571
CH5060	329	572

		<b>9</b>
CH5240	89	182
CH5242	415	728
CH6390	297	516
CKS2373	201	333
CKS2373	204	339
CKS2648	90	184
CKS2648	91	185
CKS2648	91	186
CKS3648	90	184
CKS3648	91	185
CKS3648	91	186
CM870	10	21
CN306	243	414
CN306	244	415
CN306	244	417
CN306	244	418
CN306	245	420
CN306	245	421
CN306	246	425
CN306	342	606
CN353	67	130
CN353	67	131
CN353	68	132
CN353	68	133
CN353	68	134
CN353	69	136
CN353	69	137
CN353	70	138
CN353	71	140
CN353	71	141
CN353	217	360
CN400	46	83
CY081	293	509
CY081	295	513
CY082	294	510
CY131	199	330
CY320	146	258
CY320	147	259
CY470	315	548
CY470	316	549
CY470	316	550
CY470	317	551
CY470	317	552
CY470	318	553
CY470	318	554
CY470	319	555
CY470	319	556
CY470	320	557
CY520	157	270
CY520	159	272
CY520	160	273
CY520	169	289
CY520	170	290
CY550	111	210
CY550	141	253
CY550	142	254
CY610	78	160
CY611	78	160
CY620	338	597
CY620	339	598

		<b>9</b>
CY620	339	599
CY640	395	687
CY640	398	692
CY640	398	693
CY640	399	694
CY640	400	696
CY640	404	707
CY640	404	708
CY640	405	709
CY680	417	733
CY680	418	734
CY680	420	737
DC372	56	107
DC372	57	110
DC372	58	112
DC372	58	113
DC373	56	107
DC373	58	112
DC373	74	152
DC373	243	414
DC373	342	606
DD790	54	102
DE588	345	612
DE588	351	619
DE588	358	628
DE588	359	630
DE588	359	631
DE588	381	666
DE588	388	676
DE588	389	677
DE588	390	679
DE622	71	141
DE622	217	360
DE622	218	361
DE622	219	363
DE622	219	364
DE622	220	365
DE622	221	367
DE623	222	369
DE623	222	370
DE623	232	393
DG811	197	327
DG811	198	328
DH854	75	154
DH854	76	157
DH854	76	158
DJ720	200	331
DJ720	201	333
DJ720	202	334
DJ720	203	336
DJ720	204	339
DJ851	60	118
DJ851	61	119
DJ851	61	120
DJ851	64	124
DJ851	65	125
DJ851	292	506
DJ851	292	507
DJ851	298	519
DJ851	298	520

# NUMERICAL PARTS LIST

Nummerische Teilenummernliste • Elenco riferimenti  
Liste des références produits

		 <b>9</b>
DJ851	300	522
DJ851	302	526
DJ851	309	535
DJ851	310	538
DJ852	62	121
DJ852	62	122
DJ852	63	123
DJ852	64	124
DJ852	65	125
DJ872	50	94
DJ872	51	95
DJ872	52	96
DK570	331	578
DK570	332	579
DK570	342	606
DK570	342	607
DK570	343	608
DK570	343	609
DK570	344	610
DK570	344	611
DK572	341	604
DM530	331	576
DM533	330	574
DM533	330	575
DM533	331	576
DM710	243	413
DP011	5	8
DP011	6	10
DP011	6	11
DP011	7	13
DP013	3	4
DP021	8	16
DP021	9	17
DP022	9	20
DP051	55	103
DP070	60	118
DP070	61	119
DP110	292	506
DP110	292	507
DP110	298	519
DP110	298	520
DP110	303	527
DP110	303	528
DP110	306	532
DP130	223	372
DP130	223	373
DP130	225	376
DP130	226	378
DP130	226	379
DP130	232	394
DP130	233	396
DP130	247	427
DP130	248	430
DP133	225	377
DP133	229	385
DP133	247	427
DP133	247	428
DP133	248	431
DP133	257	445
DP190	223	371

		 <b>9</b>
DP190	224	375
DP190	279	479
DP273	361	633
DP273	362	634
DP273	382	667
DP273	383	668
DP273	384	670
DP273	391	680
DP273	392	681
DP286	20	40
DP292	49	93
DP292	54	101
DP293	65	126
DP293	66	127
DP293	299	521
DP294	49	91
DP660	2	2
DP660	3	3
DP688	250	434
DP689	314	546
DP860	304	529
DP860	307	533
DP860	308	534
DP860	310	538
DP861	305	530
DP861	309	535
DP861	311	539
DP871	300	522
DP871	302	526
DP871	309	535
DR040	341	605
DR073	348	616
DR073	372	650
DR073	385	672
DR073	385	673
DR100	56	106
DR480	80	164
DR610	3	4
DR610	5	8
DR610	5	9
DR610	6	10
DR610	6	11
DR610	7	13
DR611	2	1
DR611	55	103
DR620	83	171
DR620	84	172
DR620	85	173
DR620	85	174
DR620	86	176
DR620	87	177
DR630	311	540
DR630	312	541
DR630	312	542
DR630	313	543
DR630	321	558
DR630	322	559
DR630	323	560
DR630	325	562
DR631	314	545

		 <b>9</b>
DR631	315	547
DR632	321	558
DR632	322	559
DR632	324	561
DS381	347	614
DS381	348	615
DS381	348	616
DS381	349	617
DS381	353	621
DS381	355	624
DS381	356	625
DS381	363	635
DS381	364	637
DS381	364	638
DS381	366	640
DS381	367	641
DS381	368	642
DS381	368	643
DS381	369	645
DS381	370	647
DS381	372	650
DS381	372	651
DS381	373	652
DS381	374	653
DS381	375	655
DS381	375	656
DS381	376	658
DS381	378	660
DS381	380	663
DS381	384	671
DS381	385	672
DS381	386	674
DS381	387	675
DS435	186	314
DS435	203	336
DS570	2	1
DS570	55	103
DS820	293	509
DT260	4	5
DT260	4	6
DT260	7	14
DT260	8	15
DT270	80	165
DT290	179	305
DT290	181	308
DT290	192	321
DT290	193	322
DT300	181	309
DT300	182	310
DT340	328	568
DT340	328	569
DT350	244	417
DT350	245	422
DT400	82	168
DT400	82	169
DT401	86	175
DT410	236	401
DT410	237	402
DT410	240	406
DT410	251	436

		 <b>9</b>
DT410	262	453
DT411	228	382
DT411	229	386
DT411	231	390
DT411	231	391
DT411	255	442
DT411	258	447
DT413	253	438
DT413	262	453
DT413	263	454
DT413	264	455
DT413	267	458
DT413	269	462
DT413	270	464
DT420	251	435
DT420	252	437
DT420	253	438
DT420	264	455
DT420	266	457
DT420	269	462
DT420	270	464
DT420	280	480
DT423	228	382
DT423	231	390
DT423	232	392
DT423	259	449
DT423	260	450
DT423	274	471
DT423	275	472
DT440	235	399
DT440	254	440
DT440	273	469
DT440	275	473
DT441	236	400
DT441	254	439
DT441	268	460
DT441	268	461
DT442	271	465
DT442	273	468
DT443	272	467
DT443	277	475
DT443	278	476
DT446	234	398
DT446	235	399
DT446	238	403
DT446	254	440
DT446	255	441
DT446	274	470
DT446	314	546
DT447	256	443
DT447	261	452
DT447	276	474
DT447	281	482
DT448	272	467
DT448	278	476
DT448	279	478
DT449	238	403
DT449	239	404
DT449	241	408
DT449	241	409

						9
DT449	255	<b>441</b>				
DT752	382	<b>667</b>				
DV150	288	<b>499</b>				
DV150	289	<b>500</b>				
DV672	30	<b>55</b>				
DV672	32	<b>58</b>				
DV672	33	<b>59</b>				
DV672	37	<b>63</b>				
DV672	38	<b>64</b>				
DV675	15	<b>35</b>				
DV675	16	<b>36</b>				
DV675	17	<b>37</b>				
DV675	18	<b>38</b>				
DV675	19	<b>39</b>				
DV675	21	<b>41</b>				
DV675	22	<b>43</b>				
DV675	22	<b>44</b>				
DV675	24	<b>47</b>				
DV675	25	<b>48</b>				
DV675	26	<b>49</b>				
DV675	27	<b>50</b>				
DV675	29	<b>53</b>				
DV675	29	<b>54</b>				
DV675	30	<b>55</b>				
DV675	30	<b>56</b>				
DV675	66	<b>128</b>				
DV680	172	<b>295</b>				
DV680	173	<b>296</b>				
DV680	174	<b>298</b>				
DV680	174	<b>299</b>				
DV680	175	<b>300</b>				
DV680	176	<b>301</b>				
DV680	177	<b>302</b>				
DV680	178	<b>303</b>				
DV680	179	<b>304</b>				
DV680	180	<b>306</b>				
DV680	181	<b>307</b>				
DV680	183	<b>311</b>				
DV680	184	<b>312</b>				
DV680	185	<b>313</b>				
DV680	186	<b>314</b>				
DV680	187	<b>315</b>				
DV680	188	<b>316</b>				
DV680	188	<b>317</b>				
DV680	189	<b>318</b>				
DV680	190	<b>319</b>				
DV680	191	<b>320</b>				
DV680	194	<b>323</b>				
DV680	195	<b>324</b>				
DV680	196	<b>325</b>				
DV680	197	<b>326</b>				
DW260	396	<b>688</b>				
DW260	396	<b>689</b>				
DW261	397	<b>691</b>				
DW280	78	<b>161</b>				
DW280	79	<b>162</b>				
DW280	79	<b>163</b>				
DW281	77	<b>159</b>				
DW282	77	<b>159</b>				
DW320	148	<b>260</b>				

						9
DW320	153	<b>266</b>				
DW322	149	<b>261</b>				
DW322	150	<b>262</b>				
DW322	151	<b>263</b>				
DW322	154	<b>267</b>				
DW340	156	<b>269</b>				
DW340	158	<b>271</b>				
DW410	213	<b>353</b>				
DW410	216	<b>358</b>				
DW410	217	<b>359</b>				
DW410	243	<b>412</b>				
DW410	280	<b>481</b>				
DW710	207	<b>345</b>				
DW710	212	<b>352</b>				
DW711	208	<b>346</b>				
DW711	212	<b>352</b>				
DW712	208	<b>346</b>				
DW712	208	<b>347</b>				
DW712	210	<b>349</b>				
DW720	97	<b>194</b>				
DW720	98	<b>195</b>				
DW721	93	<b>189</b>				
DW721	95	<b>192</b>				
DW721	96	<b>193</b>				
DW722	93	<b>189</b>				
DW722	95	<b>192</b>				
DW722	96	<b>193</b>				
DW722	105	<b>203</b>				
DW722	107	<b>205</b>				
DW722	108	<b>206</b>				
DW723	97	<b>194</b>				
DW723	99	<b>196</b>				
DW723	100	<b>197</b>				
DW723	103	<b>200</b>				
DW723	104	<b>201</b>				
DW723	104	<b>202</b>				
DX030	315	<b>548</b>				
DX030	316	<b>549</b>				
DX030	316	<b>550</b>				
DX030	317	<b>551</b>				
DX030	317	<b>552</b>				
DX030	318	<b>553</b>				
DX030	318	<b>554</b>				
DX030	319	<b>555</b>				
DX030	319	<b>556</b>				
DX030	320	<b>557</b>				
DX040	90	<b>184</b>				
DX040	91	<b>185</b>				
DX040	91	<b>186</b>				
DX390	405	<b>710</b>				
DX390	406	<b>711</b>				
DX390	410	<b>717</b>				
DX391	405	<b>710</b>				
DX391	406	<b>711</b>				
DX391	413	<b>724</b>				
DX391	416	<b>730</b>				
DX391	416	<b>731</b>				
DX391	417	<b>732</b>				
DX391	419	<b>736</b>				
DX392	414	<b>726</b>				

						9
DX392	415	<b>727</b>				
DX392	416	<b>731</b>				
DX400	411	<b>720</b>				
DY310	296	<b>514</b>				
DY382	28	<b>51</b>				
DY382	28	<b>52</b>				
DY382	31	<b>57</b>				
DY383	34	<b>60</b>				
DY383	35	<b>61</b>				
DY390	92	<b>187</b>				
DY391	92	<b>187</b>				
DY410	109	<b>208</b>				
DY410	110	<b>209</b>				
DZ790	117	<b>217</b>				
DZ790	127	<b>230</b>				
EA5420	521	<b>927</b>				
EA5420	522	<b>928</b>				
EA5420	523	<b>930</b>				
EA5420	524	<b>931</b>				
EA5420	525	<b>932</b>				
EA5420	525	<b>933</b>				
EA5420	598	<b>1040</b>				
EA5780	551	<b>976</b>				
EA5780	552	<b>977</b>				
EA5830	560	<b>991</b>				
EA5830	561	<b>992</b>				
EA5830	679	<b>1163</b>				
EA5830	680	<b>1165</b>				
EB5150	516	<b>916</b>				
EB5150	707	<b>1206</b>				
EB5150	708	<b>1207</b>				
EB5150	708	<b>1208</b>				
EB5150	710	<b>1210</b>				
EB5150	711	<b>1212</b>				
ED5130	471	<b>838</b>				
ED5490	683	<b>1169</b>				
ED5490	684	<b>1170</b>				
ED5500	677	<b>1160</b>				
ED5500	678	<b>1161</b>				
ED5500	678	<b>1162</b>				
ED5800	442	<b>776</b>				
ED5800	445	<b>781</b>				
ED5810	441	<b>773</b>				
ED5810	442	<b>775</b>				
ED5810	443	<b>777</b>				
ED5810	444	<b>780</b>				
ED5820	443	<b>778</b>				
ED5820	444	<b>779</b>				
ED5820	446	<b>782</b>				
ED5820	446	<b>783</b>				
ED5820	446	<b>784</b>				
ED5910	553	<b>978</b>				
ED5910	554	<b>979</b>				
ED5910	554	<b>980</b>				
ED5910	555	<b>981</b>				
ED5910	555	<b>982</b>				
ED5910	556	<b>983</b>				
ED5910	556	<b>984</b>				
ED5910	557	<b>985</b>				
ED5960	545	<b>967</b>				

						9
ED5960	547	<b>970</b>				
ED5960	547	<b>971</b>				
ED5960	599	<b>1044</b>				
ED5960	600	<b>1045</b>				
EE5180	453	<b>797</b>				
EE5180	455	<b>801</b>				
EE5180	456	<b>803</b>				
EE5180	456	<b>804</b>				
EE5180	458	<b>807</b>				
EE5180	460	<b>810</b>				
EE5180	462	<b>815</b>				
EE5180	464	<b>818</b>				
EE5180	464	<b>819</b>				
EE5181	528	<b>938</b>				
EE5181	529	<b>939</b>				
EE5181	530	<b>941</b>				
EE5181	531	<b>942</b>				
EE5181	534	<b>946</b>				
EE5181	534	<b>947</b>				
EE5181	535	<b>948</b>				
EE5181	535	<b>949</b>				
EE5181	536	<b>951</b>				
EE5181	538	<b>953</b>				
EE5181	538	<b>954</b>				
EE5181	539	<b>955</b>				
EE5181	540	<b>956</b>				
EE5181	543	<b>964</b>				
EE5242	449	<b>789</b>				
EE5242	453	<b>798</b>				
EE5242	455	<b>802</b>				
EE5242	456	<b>803</b>				
EE5242	456	<b>804</b>				
EE5242	457	<b>805</b>				
EE5242	458	<b>808</b>				
EE5242	459	<b>809</b>				
EE5242	460	<b>811</b>				
EE5242	461	<b>813</b>				
EE5242	463	<b>816</b>				
EE5242	463	<b>817</b>				
EE5242	466	<b>825</b>				
EE5242	467	<b>827</b>				
EE5242	532	<b>944</b>				
EG7390	533	<b>945</b>				
EG7390	536	<b>950</b>				
EG7390	541	<b>957</b>				
EG7390	541	<b>958</b>				
EG7390	542	<b>960</b>				
EG7410	557	<b>986</b>				
EG7410	558	<b>987</b>				
EG7410	558	<b>988</b>				
EG7410	559	<b>989</b>				
EG7450	541	<b>959</b>				
EG7450	542	<b>961</b>				
EG7450	543	<b>962</b>				
EG7450	543	<b>963</b>				
EG9750	676	<b>1156</b>				
EG9750	676	<				

# NUMERICAL PARTS LIST





Nummerische Teilenummernliste • Elenco riferimenti  
Liste des références produits

 <span style="border: 1px solid black; padding: 2px;">9</span>		
EL890	585	1022
EL890	587	1024
EL890	588	1025
EL890	589	1026
EL890	590	1027
EL890	590	1028
EL890	591	1029
EM531	719	1225
EP280	427	750
EP280	447	785
EP280	447	786
EP280	448	787
EP280	449	790
EP280	451	793
EP280	452	795
ES381	733	1252
ES381	741	1258
ES381	798	1298
ES820	687	1175
ES820	687	1176
ES820	690	1179
ET400	510	909
ET400	511	910
ET400	512	911
ET400	513	912
ET400	514	913
ET400	514	914
ET400	515	915
ET400	702	1198
ET400	703	1199
ET400	703	1200
ET400	704	1201
ET400	705	1202
ET400	705	1203
ET400	706	1204
ET400	707	1205
ET400	711	1213
ET400	712	1214
ET400	713	1215
EV140	688	1177
EV140	689	1178
EV150	681	1166
EV150	682	1167
EV670	454	799
EV670	454	800
EV670	459	809
EV684	561	993
EV684	563	994
EV684	564	995
EV684	564	996
EV684	565	997
EV684	566	998
EV684	568	1000
EV684	569	1001
EV684	570	1002
EV684	573	1006
EV684	576	1009
EV684	578	1010
EV684	582	1014
EW091	802	1302

 <span style="border: 1px solid black; padding: 2px;">9</span>		
EW320	546	968
FA5560	112	211
FA5560	113	212
FA5560	114	213
FA5560	115	214
FA5560	116	216
FA5560	118	218
FA5560	119	219
FA5560	120	220
FA5560	121	221
FA5560	122	222
FA5560	128	231
FA5560	128	232
FA5560	129	233
FA5560	130	235
FA5560	131	236
FA5560	132	237
FA5560	135	243
FA5560	135	244
FA5560	143	255
FA5560	144	256
FB5100	347	614
FB5100	348	615
FB5100	349	617
FB5100	355	624
FB5100	356	625
FB5100	357	626
FB5100	370	647
FB5100	387	675
FB5101	363	635
FB5101	364	637
FB5101	367	641
FB5101	373	652
FB5101	374	653
FB5101	376	658
FB5101	378	660
FB5101	386	674
FB5102	348	616
FB5102	372	650
FB5102	385	672
FB5721	332	580
FB5721	333	582
FB5721	334	583
FB5721	350	618
FB5721	353	621
FB5722	332	580
FB5722	333	581
FB5722	334	585
FB5722	336	589
FB5722	337	591
FB5722	361	633
FD5810	10	22
FD5810	11	25
FD5810	12	26
FD5810	14	30
FD5820	12	27
FD5820	13	28
FD5820	13	29
FD5820	14	31
FD5820	14	32

 <span style="border: 1px solid black; padding: 2px;">9</span>		
FD5820	15	33
FD5970	88	180
FD5970	89	181
FE5240	29	53
FE5240	29	54
FE5240	30	55
FE5240	30	56
FE5240	32	58
FE5240	37	63
FF24R	46	84
FF24R	57	109
FF24R	57	110
FG615	72	144
FM872	10	21
FN402	46	83
FOL38	229	386
FOL38	230	389
FOL38	231	391
FOL38	239	405
FOL38	241	408
FOL38	242	410
FOL38	258	447
FOL38	273	468
FOL73	172	294
FOL73	200	331
FOL100	90	184
FOL100	91	185
FOL100	91	186
FOL101	90	184
FOL101	91	185
FOL101	91	186
FOL104	51	95
FOL104	52	96
FOL104	60	118
FOL104	73	148
FOL104	73	149
FOL104	84	172
FOL104	86	175
FOL104	86	176
FOL104	109	208
FOL104	110	209
FOL104	111	210
FOL104	112	211
FOL104	113	212
FOL104	114	213
FOL104	115	214
FOL104	115	215
FOL104	116	216
FOL104	117	217
FOL104	118	218
FOL104	119	219
FOL104	120	220
FOL104	121	221
FOL104	122	222
FOL104	124	225
FOL104	125	226
FOL104	126	228
FOL104	126	229
FOL104	127	230
FOL104	128	231

 <span style="border: 1px solid black; padding: 2px;">9</span>		
FOL104	129	233
FOL104	130	235
FOL104	131	236
FOL104	135	243
FOL104	135	244
FOL104	136	246
FOL104	137	247
FOL104	139	250
FOL104	141	253
FOL104	142	254
FOL104	143	255
FOL104	144	256
FOL104	145	257
FOL104	157	270
FOL104	158	271
FOL104	159	272
FOL104	160	273
FOL104	161	274
FOL104	162	275
FOL104	163	276
FOL104	164	277
FOL104	169	289
FOL104	170	290
FOL104	171	291
FOL104	172	295
FOL104	173	296
FOL104	174	299
FOL104	175	300
FOL104	176	301
FOL104	177	302
FOL104	178	303
FOL104	179	304
FOL104	179	305
FOL104	180	306
FOL104	181	307
FOL104	185	313
FOL104	186	314
FOL104	187	315
FOL104	190	319
FOL104	191	320
FOL104	192	321
FOL104	194	323
FOL104	198	328
FOL104	225	376
FOL104	226	378
FOL104	229	385
FOL104	233	396
FOL104	263	454
FOL104	265	456
FOL104	271	465
FOL104	272	466
FOL104	278	476
FOL104	292	506
FOL104	292	507
FOL104	298	519
FOL104	298	520
FOL104	300	522
FOL104	301	523
FOL104	301	524
FOL104	302	525

 9			 9			 9			 9		
FOL104	302	526	FOL106	209	348	FOL145	102	199	FOL168	34	60
FOL104	303	527	FOL106	210	349	FOL145	103	200	FOL168	35	61
FOL104	303	528	FOL106	211	350	FOL145	104	201	FOL169	385	672
FOL104	304	529	FOL106	212	351	FOL145	104	202	FOL169	416	731
FOL104	305	530	FOL106	212	352	FOL145	105	203	FOL169	419	736
FOL104	305	531	FOL106	213	353	FOL145	106	204	FOL171	80	165
FOL104	307	533	FOL106	213	354	FOL145	107	205	FOL187	10	22
FOL104	308	534	FOL106	214	355	FOL145	108	206	FOL187	12	26
FOL104	309	535	FOL106	215	356	FOL145	108	207	FOL187	12	27
FOL104	309	536	FOL106	216	357	FOL145	147	259	FOL187	13	28
FOL104	310	538	FOL106	256	444	FOL145	150	262	FOL187	13	29
FOL104	311	539	FOL106	261	452	FOL145	152	265	FOL187	14	30
FOL104	311	540	FOL106	276	474	FOL145	153	266	FOL187	14	32
FOL104	312	541	FOL106	279	478	FOL145	154	267	FOL187	15	33
FOL104	312	542	FOL106	315	548	FOL145	155	268	FOL187	59	116
FOL104	313	543	FOL106	316	549	FOL145	207	345	FOL187	123	223
FOL104	313	544	FOL106	316	550	FOL145	208	346	FOL187	124	224
FOL104	314	545	FOL106	317	551	FOL145	208	347	FOL187	129	234
FOL104	314	546	FOL106	317	552	FOL145	209	348	FOL187	132	238
FOL104	315	547	FOL106	318	553	FOL145	210	349	FOL187	133	239
FOL104	321	558	FOL106	318	554	FOL145	211	350	FOL187	133	240
FOL104	322	559	FOL106	319	555	FOL145	212	351	FOL187	134	241
FOL104	323	560	FOL106	319	556	FOL145	212	352	FOL187	134	242
FOL104	324	561	FOL106	320	557	FOL145	213	353	FOL187	136	245
FOL104	325	562	FOL109	288	499	FOL145	213	354	FOL187	138	248
FOL106	88	179	FOL115	291	504	FOL145	214	355	FOL187	139	249
FOL106	88	180	FOL115	291	505	FOL145	215	356	FOL187	140	251
FOL106	89	181	FOL119	4	6	FOL145	216	357	FOL187	164	278
FOL106	92	187	FOL119	7	14	FOL145	256	444	FOL187	165	279
FOL106	92	188	FOL123	28	52	FOL145	261	452	FOL187	165	281
FOL106	93	189	FOL126	16	36	FOL145	279	478	FOL187	166	282
FOL106	94	190	FOL126	18	38	FOL145	315	548	FOL187	166	284
FOL106	95	191	FOL126	19	39	FOL145	316	549	FOL187	167	285
FOL106	95	192	FOL126	26	49	FOL145	316	550	FOL187	167	286
FOL106	96	193	FOL126	27	50	FOL145	317	551	FOL187	168	287
FOL106	97	194	FOL126	29	53	FOL145	317	552	FOL187	168	288
FOL106	98	195	FOL126	32	58	FOL145	318	553	FOL187	198	329
FOL106	100	197	FOL126	33	59	FOL145	318	554	FOL187	205	341
FOL106	101	198	FOL126	37	63	FOL145	319	555	FOL187	205	342
FOL106	102	199	FOL126	148	260	FOL145	319	556	FOL190	286	495
FOL106	103	200	FOL126	325	563	FOL145	320	557	FOL190	286	496
FOL106	104	201	FOL129	396	688	FOL150	172	294	FOL190	288	498
FOL106	104	202	FOL129	397	690	FOL150	200	331	FOL190	290	502
FOL106	105	203	FOL129	397	691	FOL150	201	333	FOL190	290	503
FOL106	106	204	FOL129	401	698	FOL150	202	334	FY291	345	612
FOL106	107	205	FOL129	402	701	FOL150	203	336	FY291	351	619
FOL106	108	206	FOL130	326	565	FOL150	203	337	FY291	352	620
FOL106	108	207	FOL130	327	566	FOL150	204	338	FY291	354	622
FOL106	146	258	FOL145	88	179	FOL150	204	339	FY291	358	628
FOL106	147	259	FOL145	89	181	FOL151	21	41	FY291	359	630
FOL106	148	260	FOL145	92	187	FOL154	285	494	FY291	381	666
FOL106	149	261	FOL145	92	188	FOL154	287	497	FY291	389	677
FOL106	150	262	FOL145	93	189	FOL161	4	5	FY291	390	679
FOL106	152	265	FOL145	94	190	FOL161	4	6	FY291	394	684
FOL106	153	266	FOL145	95	191	FOL163	285	494	FY320	146	258
FOL106	154	267	FOL145	95	192	FOL163	286	495	FY320	147	259
FOL106	155	268	FOL145	96	193	FOL163	286	496	FY520	157	270
FOL106	207	345	FOL145	97	194	FOL163	287	497	FY520	159	272
FOL106	208	346	FOL145	100	197	FOL164	329	570	FY520	160	273
FOL106	208	347	FOL145	101	198	FOL168	28	51	FY520	169	289

# NUMERICAL PARTS LIST

Nummerische Teilenummernliste • Elenco riferimenti  
Liste des références produits

			<b>9</b>
FY520	170	290	
FY550	111	210	
FY550	141	253	
FY550	142	254	
FY610	78	160	
FY611	78	160	
FY620	338	597	
FY620	339	598	
FY620	339	599	
FY640	395	687	
FY640	398	692	
FY640	398	693	
FY640	399	694	
FY640	400	696	
FY640	404	707	
FY640	404	708	
FY640	405	709	
FY690	417	733	
FY691	420	737	
GC374	56	107	
GC374	58	112	
GD671	54	102	
GD790	54	102	
GH857	56	107	
GH857	58	112	
GH857	342	606	
GJ720	200	331	
GJ720	200	332	
GJ720	201	333	
GJ720	202	334	
GJ720	202	335	
GJ720	204	339	
GJ852	62	121	
GJ852	62	122	
GJ852	64	124	
GJ852	65	125	
GJ872	50	94	
GJ872	51	95	
GJ872	52	96	
GK570	331	578	
GK570	332	579	
GK570	342	606	
GK570	342	607	
GK571	341	604	
GK572	344	611	
GK573	343	608	
GK573	343	609	
GK573	344	610	
GK573	401	700	
GK590	65	126	
GK590	66	127	
GK590	299	521	
GM533	331	576	
GP011	4	5	
GP011	5	8	
GP011	6	10	
GP011	6	11	
GP011	7	13	
GP011	8	16	
GP011	9	17	

			<b>9</b>
GP013	3	4	
GP021	9	19	
GP022	9	20	
GP051	55	103	
GP070	60	118	
GP070	61	119	
GP070	61	120	
GP282	15	35	
GP282	16	36	
GP282	17	37	
GP282	18	38	
GP282	20	40	
GP282	21	41	
GP282	22	43	
GP282	22	44	
GP282	66	128	
GP285	19	39	
GP286	20	40	
GP660	2	2	
GP660	3	3	
GP861	303	527	
GP861	304	529	
GP861	305	530	
GP861	306	532	
GP861	307	533	
GP861	308	534	
GP861	309	535	
GP861	310	538	
GP861	311	539	
GP871	300	522	
GP871	302	526	
GR100	56	106	
GR480	80	164	
GR611	2	1	
GR611	55	103	
GR620	83	171	
GR620	84	172	
GR620	85	173	
GR620	85	174	
GR620	86	176	
GR620	87	177	
GR630	312	542	
GR630	313	543	
GR630	325	562	
GS435	203	336	
GT260	4	5	
GT260	4	6	
GT260	7	14	
GT260	8	15	
GT270	80	165	
GT300	181	309	
GT300	182	310	
GT340	328	568	
GT340	328	569	
GT350	245	422	
GT400	82	168	
GT400	82	169	
GT401	86	175	
GT410	237	402	
GT410	251	436	

			<b>9</b>
GT410	262	453	
GT423	240	407	
GT423	258	447	
GT423	259	448	
GT423	259	449	
GT423	260	450	
GT423	274	471	
GT423	275	472	
GT440	235	399	
GT440	252	437	
GT440	266	457	
GT440	273	469	
GT441	268	460	
GT442	271	465	
GT446	234	398	
GT446	274	470	
GT446	312	541	
GT446	314	546	
GT447	256	443	
GT447	261	452	
GT447	276	474	
GT447	281	482	
GV680	173	296	
GV680	173	297	
GV680	174	298	
GV680	174	299	
GV680	175	300	
GV680	176	301	
GV680	177	302	
GV680	178	303	
GV680	179	304	
GV680	179	305	
GV680	180	306	
GV680	181	307	
GV680	183	311	
GV680	184	312	
GV680	185	313	
GV680	186	314	
GV680	187	315	
GV680	188	316	
GV680	188	317	
GV680	189	318	
GV680	190	319	
GV680	191	320	
GV680	192	321	
GV680	193	322	
GV680	194	323	
GV680	195	324	
GV680	196	325	
GV680	197	326	
GW280	78	161	
GW280	79	162	
GW280	79	163	
GW281	77	159	
GW282	77	159	
GW321	148	260	
GW341	156	269	
GW341	158	271	
GW410	213	353	
GW410	216	358	

			<b>9</b>
GW410	217	359	
GW410	243	412	
GW410	280	481	
GW711	208	346	
GW712	208	346	
GW712	208	347	
GW712	210	349	
GW713	207	345	
GW721	95	192	
GW721	96	193	
GW721	105	203	
GW721	107	205	
GW721	108	206	
GW722	93	189	
GW722	95	192	
GW722	96	193	
GW722	105	203	
GW722	107	205	
GW722	108	206	
GW723	99	196	
GW723	100	197	
GW723	103	200	
GW723	104	201	
GW723	104	202	
GW724	97	194	
GW724	98	195	
GX030	315	548	
GX030	316	549	
GX030	316	550	
GX030	317	551	
GX030	318	553	
GX030	318	554	
GX030	319	555	
GX030	319	556	
GX030	320	557	
GX041	90	184	
GX041	91	185	
GX041	91	186	
GX390	413	724	
GX390	417	732	
GX392	414	726	
GX392	415	727	
GX392	416	730	
GX392	416	731	
GX410	406	711	
GX410	419	736	
GY383	28	51	
GY383	28	52	
GY383	31	57	
GY383	34	60	
GY383	35	61	
GY390	92	187	
GY391	92	187	
GY411	109	208	
GY411	110	209	
GZ790	117	217	
GZ790	127	230	
H086/5	675	1155	
H086/5	676	1156	
H086/5	676	1157	



			<b>9</b>
H1011/5	441	<b>773</b>	
H1011/5	441	<b>774</b>	
H1011/5	442	<b>775</b>	
H1011/5	442	<b>776</b>	
H1011/5	443	<b>777</b>	
H1011/5	443	<b>778</b>	
H1011/5	444	<b>779</b>	
H1011/5	444	<b>780</b>	
H1011/5	445	<b>781</b>	
H1011/5	446	<b>783</b>	
H1018/5	692	<b>1181</b>	
H1018/5	692	<b>1182</b>	
H1020/5	721	<b>1229</b>	
H1020/5	723	<b>1232</b>	
H1020/5	724	<b>1234</b>	
H1020/5	725	<b>1236</b>	
H1028/5	468	<b>830</b>	
H1028/5	488	<b>870</b>	
H1028/5	488	<b>871</b>	
H1028/5	489	<b>872</b>	
H1028/5	490	<b>873</b>	
H1028/5	492	<b>876</b>	
H1028/5	492	<b>877</b>	
H1028/5	498	<b>887</b>	
H1028/5	499	<b>888</b>	
H1028/5	500	<b>889</b>	
H1028/5	504	<b>897</b>	
H1028/5	685	<b>1172</b>	
H1028/5	686	<b>1173</b>	
H1028/5	693	<b>1183</b>	
H1028/5	694	<b>1184</b>	
H1028/5	695	<b>1186</b>	
H1028/5	696	<b>1187</b>	
H1028/5	697	<b>1188</b>	
H1030/5	469	<b>833</b>	
H1030/5	470	<b>834</b>	
H1030/5	470	<b>835</b>	
H1030/5	480	<b>854</b>	
H1030/5	481	<b>855</b>	
H1030/5	482	<b>856</b>	
H1030/5	482	<b>857</b>	
H1030/5	483	<b>859</b>	
H1030/5	484	<b>860</b>	
H1030/5	498	<b>886</b>	
H1030/5	505	<b>898</b>	
H1030/5	505	<b>899</b>	
H1030/5	506	<b>900</b>	
H1030/5	599	<b>1042</b>	
H1030/5	600	<b>1046</b>	
H1030/5	600	<b>1047</b>	
H1030/5	628	<b>1092</b>	
H1030/5	629	<b>1093</b>	
H1030/5	631	<b>1097</b>	
H1030/5	632	<b>1098</b>	
H1030/5	632	<b>1099</b>	
H1030/5	633	<b>1100</b>	
H1030/5	634	<b>1101</b>	
H1030/5	635	<b>1102</b>	
H1030/5	635	<b>1103</b>	
H1030/5	636	<b>1105</b>	

			<b>9</b>
H1030/5	637	<b>1106</b>	
H1030/5	638	<b>1107</b>	
H1030/5	639	<b>1108</b>	
H1030/5	671	<b>1149</b>	
H1030/5	673	<b>1151</b>	
H1039/3	426	<b>748</b>	
H1039/3	426	<b>749</b>	
H1039/3	427	<b>751</b>	
H1039/3	428	<b>752</b>	
H1039/3	429	<b>753</b>	
H1039/3	429	<b>754</b>	
H1039/3	430	<b>755</b>	
H1039/3	430	<b>756</b>	
H1039/3	432	<b>758</b>	
H1039/3	433	<b>760</b>	
H1039/3	433	<b>761</b>	
H1039/3	435	<b>763</b>	
H1039/3	436	<b>765</b>	
H1039/3	437	<b>766</b>	
H1039/3	439	<b>769</b>	
H1039/3	439	<b>770</b>	
H1039/3	471	<b>839</b>	
H1041/4	729	<b>1244</b>	
H1043/5	473	<b>842</b>	
H1043/5	473	<b>843</b>	
H1043/5	479	<b>852</b>	
H1043/5	500	<b>890</b>	
H1043/5	501	<b>891</b>	
H1043/5	501	<b>892</b>	
H1043/5	502	<b>894</b>	
H1043/5	502	<b>895</b>	
H1043/5	503	<b>896</b>	
H1043/5	561	<b>993</b>	
H1043/5	563	<b>994</b>	
H1043/5	564	<b>995</b>	
H1043/5	569	<b>1001</b>	
H1043/5	575	<b>1008</b>	
H1043/5	576	<b>1009</b>	
H1043/5	583	<b>1016</b>	
H1043/5	583	<b>1017</b>	
H1043/5	584	<b>1018</b>	
H1043/5	605	<b>1055</b>	
H1043/5	606	<b>1056</b>	
H1043/5	606	<b>1057</b>	
H1043/5	607	<b>1058</b>	
H1043/5	608	<b>1059</b>	
H1043/5	608	<b>1060</b>	
H1043/5	609	<b>1061</b>	
H1043/5	610	<b>1062</b>	
H1043/5	610	<b>1063</b>	
H1043/5	611	<b>1064</b>	
H1043/5	612	<b>1065</b>	
H1043/5	613	<b>1066</b>	
H1043/5	614	<b>1067</b>	
H1043/5	615	<b>1068</b>	
H1043/5	616	<b>1069</b>	
H1043/5	617	<b>1072</b>	
H1043/5	619	<b>1075</b>	
H1043/5	619	<b>1076</b>	
H1043/5	620	<b>1077</b>	

			<b>9</b>
H1043/5	621	<b>1078</b>	
H1043/5	621	<b>1079</b>	
H1043/5	622	<b>1080</b>	
H1043/5	623	<b>1082</b>	
H1043/5	623	<b>1083</b>	
H1043/5	624	<b>1084</b>	
H1043/5	624	<b>1085</b>	
H1043/5	625	<b>1086</b>	
H1043/5	626	<b>1087</b>	
H1043/5	626	<b>1088</b>	
H1043/5	626	<b>1089</b>	
H1043/5	627	<b>1090</b>	
H1043/5	628	<b>1091</b>	
H1043/5	639	<b>1109</b>	
H1043/5	640	<b>1110</b>	
H1043/5	641	<b>1111</b>	
H1043/5	641	<b>1112</b>	
H1043/5	642	<b>1113</b>	
H1043/5	645	<b>1116</b>	
H1043/5	646	<b>1117</b>	
H1043/5	649	<b>1122</b>	
H1043/5	650	<b>1123</b>	
H1043/5	652	<b>1127</b>	
H1043/5	653	<b>1128</b>	
H1043/5	658	<b>1133</b>	
H1043/5	659	<b>1134</b>	
H1043/5	660	<b>1135</b>	
H1043/5	661	<b>1136</b>	
H1043/5	662	<b>1137</b>	
H1043/5	663	<b>1138</b>	
H1043/5	664	<b>1139</b>	
H1043/5	667	<b>1142</b>	
H1043/5	671	<b>1148</b>	
H1044/3	493	<b>878</b>	
H1044/3	494	<b>879</b>	
H1044/3	494	<b>880</b>	
H1044/3	495	<b>881</b>	
H1044/3	495	<b>882</b>	
H1044/3	496	<b>883</b>	
H1044/3	496	<b>884</b>	
H1044/3	497	<b>885</b>	
H1044/3	601	<b>1048</b>	
H1044/3	601	<b>1049</b>	
H1044/3	602	<b>1050</b>	
H1044/3	603	<b>1051</b>	
H1044/3	603	<b>1052</b>	
H1044/3	604	<b>1053</b>	
H1044/3	604	<b>1054</b>	
H1044/3	713	<b>1216</b>	
H1044/3	714	<b>1217</b>	
H1044/3	715	<b>1218</b>	
H1044/3	716	<b>1219</b>	
H1044/3	716	<b>1220</b>	
H1049/5	720	<b>1226</b>	
H1049/5	731	<b>1250</b>	
H1049/5	733	<b>1252</b>	
H1049/5	735	<b>1253</b>	
H1049/5	736	<b>1254</b>	
H1049/5	738	<b>1255</b>	
H1049/5	741	<b>1258</b>	

			<b>9</b>
H1049/5	742	<b>1259</b>	
H1049/5	743	<b>1260</b>	
H1049/5	745	<b>1261</b>	
H1049/5	747	<b>1262</b>	
H1049/5	749	<b>1263</b>	
H1049/5	751	<b>1264</b>	
H1049/5	753	<b>1265</b>	
H1049/5	755	<b>1266</b>	
H1049/5	757	<b>1268</b>	
H1049/5	759	<b>1269</b>	
H1049/5	760	<b>1270</b>	
H1049/5	762	<b>1271</b>	
H1049/5	764	<b>1272</b>	
H1049/5	766	<b>1275</b>	
H1049/5	767	<b>1276</b>	
H1049/5	769	<b>1277</b>	
H1049/5	770	<b>1278</b>	
H1049/5	772	<b>1279</b>	
H1049/5	773	<b>1280</b>	
H1049/5	774	<b>1281</b>	
H1049/5	776	<b>1282</b>	
H1049/5	778	<b>1283</b>	
H1049/5	781	<b>1286</b>	
H1049/5	783	<b>1288</b>	
H1049/5	785	<b>1289</b>	
H1049/5	786	<b>1290</b>	
H1049/5	788	<b>1291</b>	
H1049/5	790	<b>1293</b>	
H1049/5	792	<b>1294</b>	
H1049/5	794	<b>1295</b>	
H1049/5	796	<b>1296</b>	
H1049/5	797	<b>1297</b>	
H1049/5	799	<b>1299</b>	
H1049/5	800	<b>1300</b>	
H1049/5	803	<b>1303</b>	
H1049/5	804	<b>1305</b>	
H1049/5	806	<b>1306</b>	
H1049/5	807	<b>1307</b>	
H1049/5	809	<b>1308</b>	
H1049/5	811	<b>1309</b>	
H1049/5	812	<b>1310</b>	
H1049/5	814	<b>1311</b>	
H1049/5	816	<b>1312</b>	
H1049/5	817	<b>1313</b>	
H1049/5	819	<b>1314</b>	
H1049/5	822	<b>1318</b>	
H1049/5	824	<b>1319</b>	
H1049/5	826	<b>1320</b>	
H1057/5	436	<b>764</b>	
H1057/5	560	<b>991</b>	
H1057/5	561	<b>992</b>	
H1057/5	585	<b>1022</b>	
H1057/5	586	<b>1023</b>	
H1057/5	587	<b>1024</b>	
H1057/5	588	<b>1025</b>	
H1057/5	589	<b>1026</b>	
H1057/5	590	<b>1028</b>	
H1057/5	591	<b>1029</b>	
H1057/5	674	<b>1154</b>	
H1057/5	676	<b>1158</b>	

# NUMERICAL PARTS LIST

Numerische Teilenummernliste • Elenco riferimenti  
Liste des références produits

 <b>9</b>		
H1057/5	677	1159
H1057/5	677	1160
H1057/5	678	1161
H1057/5	678	1162
H1057/5	679	1163
H1057/5	680	1164
H1057/5	680	1165
H1057/5	681	1166
H1057/5	682	1167
H1057/5	683	1168
H1057/5	683	1169
H1057/5	684	1170
H1057/5	685	1171
H1057/5	687	1175
H1057/5	687	1176
H1057/5	688	1177
H1057/5	689	1178
H1057/5	690	1179
H1057/5	691	1180
H1067/5	427	750
H1067/5	447	785
H1067/5	447	786
H1067/5	448	787
H1067/5	449	790
H1067/5	450	791
H1067/5	451	793
H1067/5	451	794
H1067/5	452	795
H1069/5	472	840
H1069/5	473	841
H1069/5	474	844
H1069/5	475	845
H1069/5	476	846
H1069/5	477	847
H1069/5	477	848
H1069/5	477	849
H1069/5	491	874
H1069/5	491	875
H1069/5	695	1185
H1069/5	698	1189
H1071/5	471	837
H1074/5	585	1021
H1075/5	484	862
H1075/5	509	907
H1075/5	510	908
H1075/5	510	909
H1075/5	511	910
H1075/5	512	911
H1075/5	513	912
H1075/5	514	913
H1075/5	514	914
H1075/5	515	915
H1075/5	516	916
H1075/5	701	1195
H1075/5	702	1198
H1075/5	703	1199
H1075/5	703	1200
H1075/5	704	1201
H1075/5	705	1202
H1075/5	705	1203

 <b>9</b>		
H1075/5	706	1204
H1075/5	707	1205
H1075/5	707	1206
H1075/5	708	1207
H1075/5	708	1208
H1075/5	709	1209
H1075/5	710	1210
H1075/5	710	1211
H1075/5	711	1212
H1075/5	711	1213
H1075/5	712	1214
H1075/5	713	1215
H1081/3	717	1221
H1082/4	507	901
H1082/4	507	902
H1082/4	507	903
H1082/4	725	1237
H1082/4	726	1238
H1082/4	726	1239
H1082/4	727	1240
H1082/4	727	1241
H1082/4	728	1242
H1082/4	728	1243
H1082/4	828	1322
H1082/4	829	1323
H1082/4	829	1324
H1082/4	830	1325
H1082/4	830	1326
H1082/4	831	1327
H1082/4	831	1328
H1084/5	480	853
H1084/5	564	996
H1084/5	565	997
H1084/5	566	998
H1084/5	567	999
H1084/5	568	1000
H1084/5	570	1002
H1084/5	571	1003
H1084/5	572	1004
H1084/5	573	1005
H1084/5	573	1006
H1084/5	574	1007
H1084/5	578	1010
H1084/5	579	1011
H1084/5	580	1012
H1084/5	581	1013
H1084/5	582	1014
H1084/5	583	1015
H1084/5	616	1070
H1084/5	617	1071
H1084/5	617	1073
H1084/5	622	1081
H1084/5	643	1114
H1084/5	644	1115
H1084/5	647	1118
H1084/5	647	1119
H1084/5	648	1120
H1084/5	648	1121
H1084/5	650	1124
H1084/5	651	1125

 <b>9</b>		
H1084/5	652	1126
H1084/5	654	1129
H1084/5	655	1130
H1084/5	656	1131
H1084/5	657	1132
H1084/5	665	1140
H1084/5	666	1141
H1084/5	668	1143
H1084/5	669	1144
H1084/5	669	1145
H1084/5	670	1146
H1084/5	670	1147
H1084/5	672	1150
H1084/5	673	1152
H1089/5	765	1273
H1089/5	827	1321
H1091/5	427	750
H1091/5	447	785
H1091/5	447	786
H1091/5	448	787
H1091/5	449	790
H1091/5	450	791
H1091/5	451	793
H1091/5	451	794
H1091/5	452	795
H1092/5	449	789
H1092/5	453	797
H1092/5	453	798
H1092/5	454	799
H1092/5	454	800
H1092/5	455	801
H1092/5	455	802
H1092/5	456	803
H1092/5	456	804
H1092/5	457	805
H1092/5	458	807
H1092/5	458	808
H1092/5	459	809
H1092/5	460	810
H1092/5	460	811
H1092/5	461	813
H1092/5	462	815
H1092/5	463	816
H1092/5	463	817
H1092/5	464	818
H1092/5	464	819
H1092/5	465	821
H1092/5	466	825
H1092/5	467	828
H1092/5	467	829
H1094/5	486	867
H1094/5	720	1226
H1094/5	731	1250
H1094/5	733	1252
H1094/5	735	1253
H1094/5	736	1254
H1094/5	738	1255
H1094/5	741	1258
H1094/5	742	1259
H1094/5	743	1260

 <b>9</b>		
H1094/5	745	1261
H1094/5	747	1262
H1094/5	749	1263
H1094/5	751	1264
H1094/5	753	1265
H1094/5	755	1266
H1094/5	757	1268
H1094/5	759	1269
H1094/5	760	1270
H1094/5	762	1271
H1094/5	764	1272
H1094/5	766	1275
H1094/5	767	1276
H1094/5	769	1277
H1094/5	772	1279
H1094/5	773	1280
H1094/5	774	1281
H1094/5	778	1283
H1094/5	781	1286
H1094/5	783	1288
H1094/5	785	1289
H1094/5	786	1290
H1094/5	788	1291
H1094/5	790	1293
H1094/5	792	1294
H1094/5	794	1295
H1094/5	796	1296
H1094/5	797	1297
H1094/5	799	1299
H1094/5	800	1300
H1094/5	803	1303
H1094/5	804	1305
H1094/5	806	1306
H1094/5	807	1307
H1094/5	809	1308
H1094/5	811	1309
H1094/5	812	1310
H1094/5	814	1311
H1094/5	816	1312
H1094/5	817	1313
H1094/5	819	1314
H1094/5	822	1318
H1094/5	824	1319
H1094/5	826	1320
H1095/5	527	937
H1095/5	528	938
H1095/5	529	939
H1095/5	529	940
H1095/5	530	941
H1095/5	531	942
H1095/5	532	944
H1095/5	533	945
H1095/5	536	950
H1095/5	538	953
H1095/5	538	954
H1095/5	542	960
H1095/5	543	962
H1095/5	543	964
H1095/6	544	965
H1095/6	545	966

			<b>9</b>
H1095/6	545	<b>967</b>	
H1095/6	546	<b>968</b>	
H1095/6	547	<b>970</b>	
H1095/6	547	<b>971</b>	
H1095/6	548	<b>972</b>	
H1095/6	549	<b>973</b>	
H1095/6	550	<b>974</b>	
H1095/6	550	<b>975</b>	
H1095/6	551	<b>976</b>	
H1095/6	552	<b>977</b>	
H1095/6	559	<b>990</b>	
H1095/6	600	<b>1045</b>	
H1096/5	518	<b>923</b>	
H1096/5	519	<b>924</b>	
H1096/5	519	<b>925</b>	
H1096/5	520	<b>926</b>	
H1096/5	521	<b>927</b>	
H1096/5	522	<b>928</b>	
H1096/5	523	<b>929</b>	
H1096/5	523	<b>930</b>	
H1096/5	524	<b>931</b>	
H1096/5	525	<b>932</b>	
H1096/5	525	<b>933</b>	
H1096/5	526	<b>934</b>	
H1096/5	527	<b>936</b>	
H1096/5	531	<b>943</b>	
H1096/5	536	<b>951</b>	
H1096/5	596	<b>1038</b>	
H1096/5	597	<b>1039</b>	
H1096/5	598	<b>1040</b>	
H1096/5	598	<b>1041</b>	
H1096/5	618	<b>1074</b>	
H1096/5	698	<b>1190</b>	
H1096/5	698	<b>1191</b>	
H1096/5	699	<b>1192</b>	
H1096/5	700	<b>1193</b>	
H1096/5	700	<b>1194</b>	
H1096/5	701	<b>1196</b>	
H1096/5	702	<b>1197</b>	
H1104/5	770	<b>1278</b>	
H1104/5	776	<b>1282</b>	
H1104/5	778	<b>1283</b>	
H1104/5	788	<b>1291</b>	
H1104/5	790	<b>1293</b>	
H1104/5	792	<b>1294</b>	
H1104/5	802	<b>1302</b>	
H1104/5	821	<b>1316</b>	
H1104/5	832	<b>1329</b>	
H1104/5	833	<b>1331</b>	
H1104/5	834	<b>1332</b>	
H1104/5	836	<b>1334</b>	
H1104/5	837	<b>1335</b>	
H1104/5	838	<b>1336</b>	
H1104/5	839	<b>1338</b>	
H1104/5	840	<b>1339</b>	
H1104/5	841	<b>1340</b>	
H1104/5	841	<b>1341</b>	
H1104/5	842	<b>1342</b>	
H1104/5	843	<b>1343</b>	
H1104/5	844	<b>1344</b>	

			<b>9</b>
H1104/5	845	<b>1345</b>	
H1138/3	485	<b>863</b>	
H1178/3	438	<b>767</b>	
H1178/3	438	<b>768</b>	
H1240/5	629	<b>1094</b>	
H1240/5	718	<b>1224</b>	
H1240/5	719	<b>1225</b>	
H1241/5	629	<b>1094</b>	
H1241/5	630	<b>1095</b>	
H1241/5	718	<b>1224</b>	
H1241/5	719	<b>1225</b>	
H1293/5	485	<b>864</b>	
H1293/5	486	<b>865</b>	
H1293/5	486	<b>867</b>	
H1293/5	487	<b>869</b>	
H1293/5	584	<b>1019</b>	
H1331/5	483	<b>858</b>	
HA5005	88	<b>180</b>	
HA5005	89	<b>181</b>	
HA5005	316	<b>549</b>	
HA5005	316	<b>550</b>	
HA5005	317	<b>551</b>	
HA5005	317	<b>552</b>	
HA5005	318	<b>553</b>	
HA5005	318	<b>554</b>	
HA5008	172	<b>294</b>	
HA5030	47	<b>86</b>	
HA5031	47	<b>86</b>	
HA5053	23	<b>45</b>	
HA5053	23	<b>46</b>	
HA5053	36	<b>62</b>	
HA5053	39	<b>66</b>	
HA5053	39	<b>67</b>	
HA5053	42	<b>74</b>	
HA5053	43	<b>76</b>	
HBS011	174	<b>298</b>	
HBS011	227	<b>380</b>	
HBS011	227	<b>381</b>	
HBS011	305	<b>530</b>	
HBS011	307	<b>533</b>	
HBS011	310	<b>538</b>	
HBS011	311	<b>539</b>	
HBS011	345	<b>612</b>	
HBS011	347	<b>614</b>	
HBS011	348	<b>615</b>	
HBS011	348	<b>616</b>	
HBS011	349	<b>617</b>	
HBS011	351	<b>619</b>	
HBS011	352	<b>620</b>	
HBS011	354	<b>622</b>	
HBS011	355	<b>624</b>	
HBS011	356	<b>625</b>	
HBS011	357	<b>626</b>	
HBS011	358	<b>628</b>	
HBS011	359	<b>630</b>	
HBS011	359	<b>631</b>	
HBS011	361	<b>633</b>	
HBS011	362	<b>634</b>	
HBS011	363	<b>635</b>	
HBS011	363	<b>636</b>	

			<b>9</b>
HBS011	364	<b>637</b>	
HBS011	367	<b>641</b>	
HBS011	372	<b>650</b>	
HBS011	373	<b>652</b>	
HBS011	374	<b>653</b>	
HBS011	376	<b>658</b>	
HBS011	378	<b>660</b>	
HBS011	380	<b>663</b>	
HBS011	381	<b>666</b>	
HBS011	382	<b>667</b>	
HBS011	383	<b>668</b>	
HBS011	384	<b>670</b>	
HBS011	385	<b>672</b>	
HBS011	386	<b>674</b>	
HBS011	387	<b>675</b>	
HBS011	388	<b>676</b>	
HBS011	389	<b>677</b>	
HBS011	390	<b>679</b>	
HBS011	391	<b>680</b>	
HBS011	392	<b>681</b>	
HBS011	393	<b>682</b>	
HBS011	394	<b>683</b>	
HBS011	394	<b>684</b>	
HBS011	406	<b>711</b>	
HBS011	410	<b>717</b>	
HBS011	411	<b>720</b>	
HBS011	413	<b>724</b>	
HBS011	415	<b>727</b>	
HBS011	416	<b>730</b>	
HBS011	417	<b>732</b>	
HBS033	238	<b>403</b>	
HBS038	330	<b>574</b>	
HBS038	330	<b>575</b>	
HBS038	331	<b>576</b>	
HBS039	46	<b>85</b>	
HBS051	62	<b>121</b>	
HBS051	62	<b>122</b>	
HBS051	63	<b>123</b>	
HBS051	64	<b>124</b>	
HBS051	67	<b>129</b>	
HBS051	81	<b>166</b>	
HBS051	81	<b>167</b>	
HBS051	82	<b>168</b>	
HBS051	82	<b>169</b>	
HBS051	83	<b>171</b>	
HBS051	84	<b>172</b>	
HBS051	85	<b>173</b>	
HBS051	85	<b>174</b>	
HBS051	86	<b>175</b>	
HBS051	86	<b>176</b>	
HBS051	87	<b>177</b>	
HBS051	87	<b>178</b>	
HBS051	227	<b>380</b>	
HBS051	227	<b>381</b>	
HBS051	229	<b>386</b>	
HBS051	231	<b>390</b>	
HBS051	231	<b>391</b>	
HBS051	298	<b>519</b>	
HBS051	298	<b>520</b>	
HBS051	300	<b>522</b>	

			<b>9</b>
HBS051	301	<b>523</b>	
HBS051	302	<b>526</b>	
HBS051	303	<b>527</b>	
HBS051	303	<b>528</b>	
HBS051	304	<b>529</b>	
HBS051	307	<b>533</b>	
HBS051	308	<b>534</b>	
HBS051	309	<b>535</b>	
HBS051	311	<b>540</b>	
HBS051	312	<b>541</b>	
HBS051	312	<b>542</b>	
HBS051	313	<b>543</b>	
HBS051	314	<b>545</b>	
HBS051	314	<b>546</b>	
HBS051	315	<b>547</b>	
HBS051	321	<b>558</b>	
HBS051	322	<b>559</b>	
HBS051	324	<b>561</b>	
HBS051	325	<b>562</b>	
HBS052	2	<b>2</b>	
HBS052	3	<b>3</b>	
HBS052	15	<b>35</b>	
HBS052	16	<b>36</b>	
HBS052	17	<b>37</b>	
HBS052	18	<b>38</b>	
HBS052	19	<b>39</b>	
HBS052	20	<b>40</b>	
HBS052	21	<b>41</b>	
HBS052	22	<b>43</b>	
HBS052	22	<b>44</b>	
HBS052	23	<b>45</b>	
HBS052	23	<b>46</b>	
HBS052	24	<b>47</b>	
HBS052	25	<b>48</b>	
HBS052	26	<b>49</b>	
HBS052	27	<b>50</b>	
HBS052	29	<b>53</b>	
HBS052	29	<b>54</b>	
HBS052	30	<b>55</b>	
HBS052	30	<b>56</b>	
HBS052	32	<b>58</b>	
HBS052	33	<b>59</b>	
HBS052	36	<b>62</b>	
HBS052	37	<b>63</b>	
HBS052	38	<b>64</b>	
HBS052	42	<b>74</b>	
HBS052	43	<b>76</b>	
HBS052	52	<b>97</b>	
HBS052	66	<b>128</b>	
HBS052	306	<b>532</b>	
HBS055	89	<b>182</b>	
HBS084	172	<b>294</b>	
HBS084	201	<b>333</b>	
HBS084	202	<b>334</b>	
HBS084	204	<b>339</b>	
HBS084	294	<b>510</b>	
HBS084	295	<b>513</b>	
HBS084	296	<b>514</b>	
HBS087	294	<b>511</b>	
HBS087	295	<b>512</b>	

# NUMERICAL PARTS LIST

Nummerische Teilenummernliste • Elenco riferimenti  
Liste des références produits

 <b>9</b>		
HBS092	228	<b>382</b>
HBS092	228	<b>383</b>
HBS092	230	<b>387</b>
HBS092	232	<b>392</b>
HBS092	234	<b>398</b>
HBS092	235	<b>399</b>
HBS092	237	<b>402</b>
HBS092	238	<b>403</b>
HBS092	239	<b>404</b>
HBS092	240	<b>406</b>
HBS092	241	<b>408</b>
HBS092	241	<b>409</b>
HBS092	242	<b>410</b>
HBS092	250	<b>434</b>
HBS092	251	<b>435</b>
HBS092	251	<b>436</b>
HBS092	252	<b>437</b>
HBS092	253	<b>438</b>
HBS092	259	<b>449</b>
HBS092	260	<b>450</b>
HBS092	262	<b>453</b>
HBS092	264	<b>455</b>
HBS092	265	<b>456</b>
HBS092	266	<b>457</b>
HBS092	267	<b>458</b>
HBS092	267	<b>459</b>
HBS092	270	<b>464</b>
HBS092	273	<b>469</b>
HBS092	274	<b>470</b>
HBS092	274	<b>471</b>
HBS092	275	<b>472</b>
HBS092	275	<b>473</b>
HBS092	280	<b>480</b>
HBS092	321	<b>558</b>
HBS092	322	<b>559</b>
HBS092	323	<b>560</b>
HBS093	236	<b>400</b>
HBS093	254	<b>439</b>
HBS093	254	<b>440</b>
HBS093	255	<b>441</b>
HBS093	255	<b>442</b>
HBS093	256	<b>443</b>
HBS093	256	<b>444</b>
HBS093	260	<b>451</b>
HBS093	261	<b>452</b>
HBS093	268	<b>460</b>
HBS093	268	<b>461</b>
HBS093	271	<b>465</b>
HBS093	272	<b>467</b>
HBS093	273	<b>468</b>
HBS093	276	<b>474</b>
HBS093	277	<b>475</b>
HBS093	278	<b>476</b>
HBS093	279	<b>478</b>
HBS093	281	<b>482</b>
HBS095	56	<b>106</b>
HBS095	172	<b>295</b>
HBS095	173	<b>296</b>
HBS095	173	<b>297</b>
HBS095	174	<b>298</b>

 <b>9</b>		
HBS095	174	<b>299</b>
HBS095	175	<b>300</b>
HBS095	176	<b>301</b>
HBS095	177	<b>302</b>
HBS095	178	<b>303</b>
HBS095	179	<b>304</b>
HBS095	179	<b>305</b>
HBS095	180	<b>306</b>
HBS095	181	<b>307</b>
HBS095	181	<b>308</b>
HBS095	183	<b>311</b>
HBS095	184	<b>312</b>
HBS095	185	<b>313</b>
HBS095	186	<b>314</b>
HBS095	187	<b>315</b>
HBS095	188	<b>316</b>
HBS095	188	<b>317</b>
HBS095	189	<b>318</b>
HBS095	190	<b>319</b>
HBS095	191	<b>320</b>
HBS095	192	<b>321</b>
HBS095	193	<b>322</b>
HBS095	194	<b>323</b>
HBS095	195	<b>324</b>
HBS095	196	<b>325</b>
HBS095	197	<b>326</b>
HBS097	182	<b>310</b>
HBS098	65	<b>125</b>
HBS098	65	<b>126</b>
HBS098	66	<b>127</b>
HBS105	331	<b>578</b>
HBS105	332	<b>579</b>
HBS105	342	<b>606</b>
HBS105	342	<b>607</b>
HBS105	343	<b>608</b>
HBS105	343	<b>609</b>
HBS105	344	<b>610</b>
HBS105	344	<b>611</b>
HBS106	341	<b>604</b>
HBS107	341	<b>605</b>
HBS108	343	<b>608</b>
HBS108	344	<b>611</b>
HBS125	288	<b>499</b>
HBS125	289	<b>500</b>
HBS130	90	<b>184</b>
HBS130	91	<b>185</b>
HBS130	91	<b>186</b>
HBS131	88	<b>180</b>
HBS131	89	<b>181</b>
HBS131	315	<b>548</b>
HBS131	316	<b>549</b>
HBS131	316	<b>550</b>
HBS131	317	<b>551</b>
HBS131	317	<b>552</b>
HBS131	318	<b>553</b>
HBS131	318	<b>554</b>
HBS131	319	<b>555</b>
HBS131	319	<b>556</b>
HBS131	320	<b>557</b>
HBS132	93	<b>189</b>

 <b>9</b>		
HBS132	95	<b>192</b>
HBS132	96	<b>193</b>
HBS132	97	<b>194</b>
HBS132	98	<b>195</b>
HBS132	99	<b>196</b>
HBS132	100	<b>197</b>
HBS132	101	<b>198</b>
HBS132	102	<b>199</b>
HBS132	103	<b>200</b>
HBS132	104	<b>201</b>
HBS132	104	<b>202</b>
HBS132	105	<b>203</b>
HBS132	107	<b>205</b>
HBS132	108	<b>206</b>
HBS132	206	<b>344</b>
HBS132	208	<b>346</b>
HBS132	209	<b>348</b>
HBS132	210	<b>349</b>
HBS132	211	<b>350</b>
HBS133	146	<b>258</b>
HBS133	147	<b>259</b>
HBS133	148	<b>260</b>
HBS133	149	<b>261</b>
HBS133	150	<b>262</b>
HBS133	151	<b>263</b>
HBS133	151	<b>264</b>
HBS133	152	<b>265</b>
HBS133	153	<b>266</b>
HBS133	154	<b>267</b>
HBS133	155	<b>268</b>
HBS133	213	<b>354</b>
HBS133	214	<b>355</b>
HBS133	216	<b>357</b>
HBS186	57	<b>108</b>
HBS186	74	<b>153</b>
HBS186	75	<b>156</b>
HBS186	76	<b>157</b>
HBS186	76	<b>158</b>
HBS227	109	<b>208</b>
HBS227	110	<b>209</b>
HBS227	111	<b>210</b>
HBS227	112	<b>211</b>
HBS227	113	<b>212</b>
HBS227	114	<b>213</b>
HBS227	115	<b>214</b>
HBS227	115	<b>215</b>
HBS227	116	<b>216</b>
HBS227	117	<b>217</b>
HBS227	118	<b>218</b>
HBS227	119	<b>219</b>
HBS227	120	<b>220</b>
HBS227	121	<b>221</b>
HBS227	122	<b>222</b>
HBS227	124	<b>225</b>
HBS227	125	<b>226</b>
HBS227	125	<b>227</b>
HBS227	126	<b>228</b>
HBS227	126	<b>229</b>
HBS227	127	<b>230</b>
HBS227	128	<b>231</b>

 <b>9</b>		
HBS227	128	<b>232</b>
HBS227	129	<b>233</b>
HBS227	130	<b>235</b>
HBS227	131	<b>236</b>
HBS227	132	<b>237</b>
HBS227	135	<b>243</b>
HBS227	135	<b>244</b>
HBS227	136	<b>246</b>
HBS227	137	<b>247</b>
HBS227	139	<b>250</b>
HBS227	141	<b>253</b>
HBS227	142	<b>254</b>
HBS227	143	<b>255</b>
HBS227	144	<b>256</b>
HBS227	145	<b>257</b>
HBS245	172	<b>294</b>
HBS245	293	<b>509</b>
HBS247	28	<b>51</b>
HBS247	28	<b>52</b>
HBS247	31	<b>57</b>
HBS247	34	<b>60</b>
HBS247	35	<b>61</b>
HBS247	38	<b>65</b>
HBS247	39	<b>66</b>
HBS247	39	<b>67</b>
HBS247	40	<b>68</b>
HBS247	40	<b>69</b>
HBS247	41	<b>70</b>
HBS247	41	<b>72</b>
HBS247	42	<b>73</b>
HBS247	42	<b>75</b>
HBS247	44	<b>77</b>
HBS247	44	<b>78</b>
HBS247	45	<b>79</b>
HBS247	45	<b>81</b>
HBS247	45	<b>82</b>
HBS251	332	<b>580</b>
HBS251	333	<b>581</b>
HBS251	333	<b>582</b>
HBS251	334	<b>583</b>
HBS251	334	<b>585</b>
HBS251	335	<b>586</b>
HBS251	336	<b>588</b>
HBS251	336	<b>589</b>
HBS251	337	<b>591</b>
HBS251	350	<b>618</b>
HBS255	406	<b>711</b>
HBS255	414	<b>726</b>
HBS255	416	<b>731</b>
HBS255	417	<b>733</b>
HBS255	419	<b>736</b>
HBS255	420	<b>737</b>
HBS257	156	<b>269</b>
HBS257	157	<b>270</b>
HBS257	158	<b>271</b>
HBS257	159	<b>272</b>
HBS257	160	<b>273</b>
HBS257	161	<b>274</b>
HBS257	162	<b>275</b>
HBS257	163	<b>276</b>

			<b>9</b>
HBS257	164	<b>277</b>	
HBS257	169	<b>289</b>	
HBS257	170	<b>290</b>	
HBS257	171	<b>291</b>	
HBS259	282	<b>485</b>	
HBS259	282	<b>486</b>	
HBS259	283	<b>487</b>	
HBS260	199	<b>330</b>	
HBS261	283	<b>489</b>	
HBS261	284	<b>490</b>	
HBS261	284	<b>492</b>	
HBS261	285	<b>493</b>	
HBS261	285	<b>494</b>	
HBS261	286	<b>495</b>	
HBS261	286	<b>496</b>	
HBS261	287	<b>497</b>	
HBS261	288	<b>498</b>	
HBS261	291	<b>504</b>	
HBS261	291	<b>505</b>	
HBS262	92	<b>187</b>	
HBS262	94	<b>190</b>	
HBS262	95	<b>191</b>	
HBS262	106	<b>204</b>	
HBS272	329	<b>570</b>	
HBS272	329	<b>572</b>	
HBS272	395	<b>687</b>	
HBS277	200	<b>331</b>	
HBS277	200	<b>332</b>	
HBS277	202	<b>335</b>	
HBS277	203	<b>336</b>	
HBS279	5	<b>8</b>	
HBS279	5	<b>9</b>	
HBS279	47	<b>88</b>	
HBS297	2	<b>1</b>	
HBS297	4	<b>5</b>	
HBS297	4	<b>6</b>	
HBS297	6	<b>10</b>	
HBS297	6	<b>11</b>	
HBS297	7	<b>13</b>	
HBS297	7	<b>14</b>	
HBS297	8	<b>15</b>	
HBS353	10	<b>22</b>	
HBS353	11	<b>24</b>	
HBS353	11	<b>25</b>	
HBS353	12	<b>26</b>	
HBS353	12	<b>27</b>	
HBS353	13	<b>28</b>	
HBS353	13	<b>29</b>	
HBS353	14	<b>30</b>	
HBS353	14	<b>31</b>	
HBS353	14	<b>32</b>	
HBS353	15	<b>33</b>	
HBS359	47	<b>86</b>	
HBS370	123	<b>223</b>	
HBS370	124	<b>224</b>	
HBS370	132	<b>238</b>	
HBS370	133	<b>239</b>	
HBS370	133	<b>240</b>	
HBS370	134	<b>241</b>	
HBS370	134	<b>242</b>	

			<b>9</b>
HBS370	136	<b>245</b>	
HBS370	138	<b>248</b>	
HBS370	139	<b>249</b>	
HBS370	140	<b>251</b>	
HBS370	140	<b>252</b>	
HBS371	164	<b>278</b>	
HBS371	165	<b>279</b>	
HBS371	165	<b>281</b>	
HBS371	166	<b>282</b>	
HBS371	166	<b>283</b>	
HBS371	167	<b>285</b>	
HBS371	167	<b>286</b>	
HBS371	168	<b>287</b>	
HBS371	168	<b>288</b>	
HBS416	297	<b>517</b>	
HBS464	422	<b>743</b>	
HBS465	138	<b>248</b>	
HBS465	139	<b>249</b>	
HBS465	140	<b>251</b>	
HBS465	140	<b>252</b>	
HBS497	58	<b>111</b>	
HBS535	281	<b>484</b>	
HC027	428	<b>752</b>	
HC027	429	<b>753</b>	
HC027	432	<b>758</b>	
HC027	433	<b>760</b>	
HC027	433	<b>761</b>	
HC027	434	<b>762</b>	
HC027	439	<b>770</b>	
HC027	471	<b>839</b>	
HL700	92	<b>187</b>	
HL700	94	<b>190</b>	
HL700	95	<b>192</b>	
HL700	96	<b>193</b>	
HL700	105	<b>203</b>	
HL700	107	<b>205</b>	
HL700	108	<b>206</b>	
HL700	207	<b>345</b>	
HL700	208	<b>346</b>	
HL700	210	<b>349</b>	
HL700	212	<b>351</b>	
HL701	97	<b>194</b>	
HL701	98	<b>195</b>	
HL701	99	<b>196</b>	
HL701	100	<b>197</b>	
HL701	101	<b>198</b>	
HL701	102	<b>199</b>	
HL701	103	<b>200</b>	
HL701	104	<b>201</b>	
HL701	104	<b>202</b>	
HM5289	283	<b>489</b>	
HM5289	284	<b>490</b>	
HM5289	284	<b>492</b>	
HM5289	285	<b>493</b>	
HM5369	290	<b>503</b>	
HR300	248	<b>432</b>	
HR300	292	<b>507</b>	
HR363	71	<b>140</b>	
HR363	81	<b>166</b>	
HR363	81	<b>167</b>	

			<b>9</b>
HR363	82	<b>168</b>	
HR363	82	<b>169</b>	
HR363	84	<b>172</b>	
HR363	85	<b>173</b>	
HR363	85	<b>174</b>	
HR363	86	<b>175</b>	
HR363	86	<b>176</b>	
HR363	87	<b>177</b>	
HR363	109	<b>208</b>	
HR363	110	<b>209</b>	
HR363	111	<b>210</b>	
HR363	112	<b>211</b>	
HR363	113	<b>212</b>	
HR363	114	<b>213</b>	
HR363	115	<b>214</b>	
HR363	116	<b>216</b>	
HR363	117	<b>217</b>	
HR363	118	<b>218</b>	
HR363	119	<b>219</b>	
HR363	120	<b>220</b>	
HR363	121	<b>221</b>	
HR363	122	<b>222</b>	
HR363	125	<b>226</b>	
HR363	125	<b>227</b>	
HR363	126	<b>228</b>	
HR363	126	<b>229</b>	
HR363	127	<b>230</b>	
HR363	128	<b>231</b>	
HR363	128	<b>232</b>	
HR363	129	<b>233</b>	
HR363	130	<b>235</b>	
HR363	131	<b>236</b>	
HR363	132	<b>237</b>	
HR363	135	<b>243</b>	
HR363	135	<b>244</b>	
HR363	136	<b>246</b>	
HR363	137	<b>247</b>	
HR363	139	<b>250</b>	
HR363	141	<b>253</b>	
HR363	142	<b>254</b>	
HR363	143	<b>255</b>	
HR363	144	<b>256</b>	
HR363	145	<b>257</b>	
HR363	156	<b>269</b>	
HR363	157	<b>270</b>	
HR363	158	<b>271</b>	
HR363	159	<b>272</b>	
HR363	160	<b>273</b>	
HR363	161	<b>274</b>	
HR363	162	<b>275</b>	
HR363	163	<b>276</b>	
HR363	164	<b>277</b>	
HR363	170	<b>290</b>	
HR363	179	<b>305</b>	
HR363	181	<b>309</b>	
HR363	189	<b>318</b>	
HR363	190	<b>319</b>	
HR363	197	<b>326</b>	
HR363	213	<b>353</b>	
HR363	216	<b>358</b>	

			<b>9</b>
HR363	217	<b>359</b>	
HR363	222	<b>369</b>	
HR363	222	<b>370</b>	
HR363	223	<b>372</b>	
HR363	226	<b>379</b>	
HR363	227	<b>380</b>	
HR363	227	<b>381</b>	
HR363	231	<b>390</b>	
HR363	232	<b>393</b>	
HR363	234	<b>398</b>	
HR363	235	<b>399</b>	
HR363	237	<b>402</b>	
HR363	238	<b>403</b>	
HR363	240	<b>406</b>	
HR363	241	<b>409</b>	
HR363	243	<b>412</b>	
HR363	244	<b>417</b>	
HR363	245	<b>422</b>	
HR363	251	<b>436</b>	
HR363	255	<b>441</b>	
HR363	262	<b>453</b>	
HR363	264	<b>455</b>	
HR363	266	<b>457</b>	
HR363	270	<b>464</b>	
HR363	273	<b>469</b>	
HR363	280	<b>480</b>	
HR363	280	<b>481</b>	
HR363	301	<b>524</b>	
HR363	312	<b>541</b>	
HR363	312	<b>542</b>	
HR363	313	<b>543</b>	
HR363	314	<b>545</b>	
HR363	315	<b>547</b>	
HR363	321	<b>558</b>	
HR363	324	<b>561</b>	
HR363	325	<b>562</b>	
HR363	325	<b>563</b>	
HR363	326	<b>564</b>	
HR363	326	<b>565</b>	
HR397	441	<b>773</b>	
HR397	442	<b>775</b>	
HR397	442	<b>776</b>	
HR397	443	<b>777</b>	
HR397	443	<b>778</b>	
HR397	444	<b>779</b>	
HR397	444	<b>780</b>	
HR397	445	<b>781</b>	
HR397	446	<b>782</b>	
HR397	446	<b>783</b>	
HR397	446	<b>784</b>	
HR397	447	<b>785</b>	
HR397	447	<b>786</b>	
HR397	448	<b>787</b>	
HR397	449	<b>789</b>	
HR397	449	<b>790</b>	
HR397	451	<b>793</b>	
HR397	452	<b>795</b>	
HR397	453	<b>797</b>	
HR397	453	<b>798</b>	
HR397	454	<b>799</b>	

# NUMERICAL PARTS LIST

Numerische Teilenummernliste • Elenco riferimenti  
Liste des références produits

 9		
HR397	454	800
HR397	455	801
HR397	455	802
HR397	456	803
HR397	456	804
HR397	457	805
HR397	458	807
HR397	458	808
HR397	459	809
HR397	460	810
HR397	460	811
HR397	461	813
HR397	462	815
HR397	463	816
HR397	463	817
HR397	464	818
HR397	464	819
HR397	465	821
HR397	465	822
HR397	466	824
HR397	466	825
HR397	471	838
HR397	492	876
HR397	516	916
HR397	516	917
HR397	517	918
HR397	518	923
HR397	519	924
HR397	520	926
HR397	521	927
HR397	522	928
HR397	523	929
HR397	523	930
HR397	524	931
HR397	525	932
HR397	525	933
HR397	527	936
HR397	527	937
HR397	528	938
HR397	529	939
HR397	530	941
HR397	531	942
HR397	531	943
HR397	532	944
HR397	533	945
HR397	534	946
HR397	534	947
HR397	535	948
HR397	535	949
HR397	536	950
HR397	536	951
HR397	537	952
HR397	538	953
HR397	538	954
HR397	539	955
HR397	540	956
HR397	541	957
HR397	541	958
HR397	541	959
HR397	542	960

 9		
HR397	542	961
HR397	543	962
HR397	543	963
HR397	543	964
HR397	544	965
HR397	545	966
HR397	545	967
HR397	546	968
HR397	547	969
HR397	547	970
HR397	547	971
HR397	548	972
HR397	549	973
HR397	550	974
HR397	550	975
HR397	551	976
HR397	552	977
HR397	553	978
HR397	554	979
HR397	554	980
HR397	555	981
HR397	555	982
HR397	556	983
HR397	556	984
HR397	557	985
HR397	557	986
HR397	558	987
HR397	558	988
HR397	559	989
HR397	559	990
HR397	592	1030
HR397	593	1032
HR397	594	1034
HR397	595	1035
HR397	595	1036
HR397	596	1037
HR397	596	1038
HR397	597	1039
HR397	598	1040
HR397	599	1042
HR397	599	1043
HR397	599	1044
HR397	600	1045
HR397	673	1151
HR397	674	1153
HR397	674	1154
HR397	675	1155
HR397	676	1156
HR397	676	1157
HR397	676	1158
HR397	677	1160
HR397	678	1161
HR397	678	1162
HR397	679	1163
HR397	680	1164
HR397	680	1165
HR397	683	1168
HR397	683	1169
HR397	684	1170
HR397	686	1174

 9		
HR397	688	1177
HR397	689	1178
HR397	692	1182
HR397	707	1205
HR397	707	1206
HR397	708	1207
HR397	709	1209
HR397	717	1222
HR397	718	1223
HR397	728	1243
HR569	53	98
HR569	61	120
HR569	72	143
HR569	72	144
HR569	73	150
HR569	74	151
HR569	83	170
HR569	85	174
HR569	172	294
HR569	182	310
HR569	200	331
HR569	201	333
HR569	202	334
HR569	203	336
HR569	204	339
HR569	223	371
HR569	247	428
HR569	251	435
HR569	252	437
HR569	253	438
HR569	254	440
HR569	292	506
HR569	292	507
HR569	314	546
HR569	325	562
HR569	331	576
HR596	49	92
HR596	50	94
HR596	51	95
HR596	52	96
HR596	53	98
HR596	55	103
HR596	56	106
HR596	60	118
HR596	61	119
HR596	62	121
HR596	62	122
HR596	63	123
HR596	64	124
HR596	65	125
HR596	65	126
HR596	66	127
HR596	83	171
HR596	173	296
HR596	173	297
HR596	174	298
HR596	174	299
HR596	175	300
HR596	176	301
HR596	177	302

 9		
HR596	178	303
HR596	179	304
HR596	180	306
HR596	181	307
HR596	181	308
HR596	185	313
HR596	191	320
HR596	192	321
HR596	193	322
HR596	196	325
HR596	198	328
HR596	224	375
HR596	228	384
HR596	233	396
HR596	250	434
HR596	279	479
HR596	298	520
HR596	299	521
HR596	300	522
HR596	301	523
HR596	302	526
HR596	303	527
HR596	303	528
HR596	304	529
HR596	305	530
HR596	306	532
HR596	307	533
HR596	310	538
HR596	311	539
HR599	2	1
HR599	2	2
HR599	3	3
HR599	3	4
HR599	4	5
HR599	4	6
HR599	5	7
HR599	5	8
HR599	5	9
HR599	6	10
HR599	6	11
HR599	7	12
HR599	7	13
HR599	7	14
HR599	8	15
HR599	9	20
HR599	15	35
HR599	16	36
HR599	17	37
HR599	18	38
HR599	19	39
HR599	20	40
HR599	21	41
HR599	21	42
HR599	22	43
HR599	22	44
HR599	24	47
HR599	25	48
HR599	26	49
HR599	27	50
HR599	29	53

			<b>9</b>
HR599	29	<b>54</b>	
HR599	30	<b>55</b>	
HR599	30	<b>56</b>	
HR599	33	<b>59</b>	
HR599	37	<b>63</b>	
HR599	38	<b>64</b>	
HR599	47	<b>87</b>	
HR599	47	<b>88</b>	
HR599	52	<b>97</b>	
HR599	66	<b>128</b>	
HR599	92	<b>187</b>	
HR599	93	<b>189</b>	
HR599	94	<b>190</b>	
HR599	95	<b>191</b>	
HR599	95	<b>192</b>	
HR599	96	<b>193</b>	
HR599	98	<b>195</b>	
HR599	99	<b>196</b>	
HR599	103	<b>200</b>	
HR599	104	<b>201</b>	
HR599	104	<b>202</b>	
HR599	105	<b>203</b>	
HR599	106	<b>204</b>	
HR599	107	<b>205</b>	
HR599	108	<b>206</b>	
HR599	207	<b>345</b>	
HR599	208	<b>346</b>	
HR599	208	<b>347</b>	
HR599	209	<b>348</b>	
HR599	210	<b>349</b>	
HR599	211	<b>350</b>	
HR599	212	<b>351</b>	
HR599	236	<b>400</b>	
HR599	254	<b>439</b>	
HR599	255	<b>442</b>	
HR599	256	<b>443</b>	
HR599	256	<b>444</b>	
HR599	260	<b>451</b>	
HR599	261	<b>452</b>	
HR599	268	<b>460</b>	
HR599	268	<b>461</b>	
HR599	271	<b>465</b>	
HR599	272	<b>466</b>	
HR599	272	<b>467</b>	
HR599	273	<b>468</b>	
HR599	276	<b>474</b>	
HR599	277	<b>475</b>	
HR599	281	<b>482</b>	
HR599	316	<b>550</b>	
HR599	318	<b>554</b>	
HR599	319	<b>555</b>	
HR599	319	<b>556</b>	
HR599	320	<b>557</b>	
HR599	385	<b>673</b>	
HR602	67	<b>131</b>	
HR602	69	<b>136</b>	
HR602	69	<b>137</b>	
HR602	70	<b>138</b>	
HR602	71	<b>140</b>	
HR602	215	<b>356</b>	

			<b>9</b>
HR602	345	<b>612</b>	
HR602	347	<b>614</b>	
HR602	348	<b>615</b>	
HR602	348	<b>616</b>	
HR602	349	<b>617</b>	
HR602	350	<b>618</b>	
HR602	351	<b>619</b>	
HR602	352	<b>620</b>	
HR602	353	<b>621</b>	
HR602	355	<b>624</b>	
HR602	356	<b>625</b>	
HR602	357	<b>626</b>	
HR602	359	<b>630</b>	
HR602	361	<b>633</b>	
HR602	362	<b>634</b>	
HR602	363	<b>635</b>	
HR602	364	<b>637</b>	
HR602	367	<b>641</b>	
HR602	373	<b>652</b>	
HR602	374	<b>653</b>	
HR602	376	<b>658</b>	
HR602	378	<b>660</b>	
HR602	380	<b>663</b>	
HR602	381	<b>666</b>	
HR602	385	<b>672</b>	
HR602	386	<b>674</b>	
HR602	387	<b>675</b>	
HR602	388	<b>676</b>	
HR602	389	<b>677</b>	
HR602	390	<b>679</b>	
HR602	394	<b>684</b>	
HR602	406	<b>711</b>	
HR602	410	<b>717</b>	
HR602	411	<b>720</b>	
HR602	413	<b>724</b>	
HR602	414	<b>726</b>	
HR602	415	<b>727</b>	
HR602	416	<b>730</b>	
HR602	416	<b>731</b>	
HR602	417	<b>732</b>	
HR602	417	<b>733</b>	
HR602	418	<b>734</b>	
HR602	419	<b>736</b>	
HR602	420	<b>737</b>	
HR646	212	<b>352</b>	
HR662	90	<b>184</b>	
HR662	91	<b>185</b>	
HR662	91	<b>186</b>	
HR662	358	<b>628</b>	
HR662	395	<b>686</b>	
HR662	395	<b>687</b>	
HR662	404	<b>706</b>	
HR662	404	<b>707</b>	
HR662	404	<b>708</b>	
HR662	405	<b>709</b>	
HR782	359	<b>630</b>	
HR791	12	<b>27</b>	
HR791	13	<b>28</b>	
HR791	13	<b>29</b>	
HR791	14	<b>31</b>	

			<b>9</b>
HR791	14	<b>32</b>	
HR791	15	<b>33</b>	
HR800	32	<b>58</b>	
HR800	88	<b>180</b>	
HR800	89	<b>181</b>	
HR800	97	<b>194</b>	
HR800	100	<b>197</b>	
HR800	101	<b>198</b>	
HR800	102	<b>199</b>	
HR800	146	<b>258</b>	
HR800	147	<b>259</b>	
HR800	148	<b>260</b>	
HR800	149	<b>261</b>	
HR800	150	<b>262</b>	
HR800	151	<b>263</b>	
HR800	151	<b>264</b>	
HR800	152	<b>265</b>	
HR800	153	<b>266</b>	
HR800	154	<b>267</b>	
HR800	213	<b>354</b>	
HR800	214	<b>355</b>	
HR800	278	<b>476</b>	
HR800	315	<b>548</b>	
HR800	316	<b>549</b>	
HR800	317	<b>551</b>	
HR800	317	<b>552</b>	
HR800	318	<b>553</b>	
HR800	328	<b>568</b>	
HR800	328	<b>569</b>	
HR800	401	<b>700</b>	
HR801	388	<b>676</b>	
HR805	53	<b>99</b>	
HR805	288	<b>499</b>	
HR814	28	<b>51</b>	
HR814	28	<b>52</b>	
HR814	31	<b>57</b>	
HR814	34	<b>60</b>	
HR814	35	<b>61</b>	
HR814	40	<b>68</b>	
HR814	40	<b>69</b>	
HR814	41	<b>70</b>	
HR814	41	<b>72</b>	
HR814	42	<b>73</b>	
HR814	42	<b>75</b>	
HR814	44	<b>77</b>	
HR814	44	<b>78</b>	
HR814	45	<b>79</b>	
HR814	45	<b>81</b>	
HR815	77	<b>159</b>	
HR815	78	<b>160</b>	
HR815	397	<b>691</b>	
HR816	216	<b>357</b>	
HR5046	283	<b>489</b>	
HR5046	284	<b>490</b>	
HR5046	285	<b>493</b>	
HR5046	285	<b>494</b>	
HR5046	286	<b>495</b>	
HR5046	291	<b>505</b>	
HR5062	329	<b>570</b>	
HR5062	329	<b>572</b>	

			<b>9</b>
HR5064	284	<b>490</b>	
HR5064	287	<b>497</b>	
HR5082	297	<b>516</b>	
HR5088	10	<b>22</b>	
HR5088	11	<b>25</b>	
HR5088	12	<b>26</b>	
HR5088	14	<b>30</b>	
HR5095	123	<b>223</b>	
HR5095	124	<b>224</b>	
HR5095	132	<b>238</b>	
HR5095	133	<b>239</b>	
HR5095	133	<b>240</b>	
HR5095	134	<b>241</b>	
HR5095	134	<b>242</b>	
HR5095	136	<b>245</b>	
HR5095	138	<b>248</b>	
HR5095	139	<b>249</b>	
HR5095	140	<b>251</b>	
HR5095	140	<b>252</b>	
JA752	10	<b>21</b>	
JA752	46	<b>83</b>	
JA752	54	<b>102</b>	
JA752	55	<b>103</b>	
JA755	10	<b>21</b>	
JA757	73	<b>149</b>	
JA757	223	<b>372</b>	
JA757	223	<b>373</b>	
JA757	224	<b>374</b>	
JA757	225	<b>376</b>	
JA757	225	<b>377</b>	
JA757	226	<b>378</b>	
JA757	226	<b>379</b>	
JA757	227	<b>380</b>	
JA757	227	<b>381</b>	
JA757	231	<b>390</b>	
JA757	233	<b>396</b>	
JA757	235	<b>399</b>	
JA757	237	<b>402</b>	
JA757	239	<b>405</b>	
JA757	240	<b>406</b>	
JA757	240	<b>407</b>	
JA757	242	<b>410</b>	
JA757	250	<b>434</b>	
JA757	251	<b>436</b>	
JA757	252	<b>437</b>	
JA757	253	<b>438</b>	
JA757	259	<b>448</b>	
JA757	262	<b>453</b>	
JA757	266	<b>457</b>	
JA757	270	<b>464</b>	
JA757	273	<b>469</b>	
JA757	312	<b>541</b>	
JA757	314	<b>546</b>	
JA777	73	<b>149</b>	
JA777	223	<b>372</b>	
JA777	223	<b>373</b>	
JA777	224	<b>374</b>	
JA777	225	<b>376</b>	
JA777	226	<b>378</b>	
JA777	226	<b>379</b>	

# NUMERICAL PARTS LIST

Numerische Teilenummernliste • Elenco riferimenti  
Liste des références produits

			<b>9</b>
JA777	233	<b>396</b>	
JA829	46	<b>84</b>	
JA829	56	<b>107</b>	
JA829	57	<b>110</b>	
JA829	58	<b>112</b>	
JA829	71	<b>142</b>	
JA829	74	<b>152</b>	
JA829	75	<b>154</b>	
JA829	75	<b>155</b>	
JA829	76	<b>157</b>	
JA829	76	<b>158</b>	
JA829	243	<b>414</b>	
JA829	244	<b>415</b>	
JA829	244	<b>416</b>	
JA829	244	<b>418</b>	
JA829	244	<b>419</b>	
JA829	245	<b>420</b>	
JA829	245	<b>421</b>	
JA829	246	<b>424</b>	
JA829	246	<b>425</b>	
JA829	342	<b>606</b>	
JA840	56	<b>107</b>	
JA840	57	<b>110</b>	
JA840	58	<b>112</b>	
JA840	71	<b>142</b>	
JA840	74	<b>152</b>	
JA840	75	<b>154</b>	
JA840	75	<b>155</b>	
JA840	243	<b>414</b>	
JA840	244	<b>419</b>	
JA840	245	<b>420</b>	
JA840	246	<b>424</b>	
JA840	246	<b>425</b>	
JA840	246	<b>426</b>	
JA840	342	<b>606</b>	
JA899	67	<b>130</b>	
JA899	67	<b>131</b>	
JA899	68	<b>132</b>	
JA899	69	<b>136</b>	
JA899	69	<b>137</b>	
JA899	70	<b>138</b>	
JA899	71	<b>140</b>	
JA899	217	<b>360</b>	
JA899	218	<b>361</b>	
JA899	219	<b>363</b>	
JA899	219	<b>364</b>	
JA899	221	<b>367</b>	
JA899	222	<b>369</b>	
JA899	222	<b>370</b>	
JA899	232	<b>393</b>	
JA899	325	<b>563</b>	
JA899	326	<b>564</b>	
JA899	326	<b>565</b>	
JA899	327	<b>567</b>	
JA5005	34	<b>60</b>	
JA5005	35	<b>61</b>	
JA5006	34	<b>60</b>	
JA5006	35	<b>61</b>	
JA5006	38	<b>65</b>	
JA5006	39	<b>66</b>	

			<b>9</b>
JA5006	39	<b>67</b>	
JA5006	44	<b>77</b>	
JA5007	97	<b>194</b>	
JA5007	103	<b>200</b>	
JA5007	104	<b>201</b>	
JA5007	104	<b>202</b>	
JA5008	117	<b>217</b>	
JA5010	20	<b>40</b>	
JA5010	32	<b>58</b>	
JA5010	33	<b>59</b>	
JA5010	37	<b>63</b>	
JA5010	38	<b>64</b>	
JA5011	117	<b>217</b>	
JA5011	127	<b>230</b>	
JA5035	111	<b>210</b>	
JA5035	112	<b>211</b>	
JA5035	113	<b>212</b>	
JA5035	114	<b>213</b>	
JA5035	115	<b>214</b>	
JA5035	115	<b>215</b>	
JA5035	116	<b>216</b>	
JA5035	118	<b>218</b>	
JA5035	119	<b>219</b>	
JA5035	120	<b>220</b>	
JA5035	121	<b>221</b>	
JA5035	122	<b>222</b>	
JA5035	128	<b>231</b>	
JA5035	128	<b>232</b>	
JA5035	129	<b>233</b>	
JA5035	130	<b>235</b>	
JA5035	131	<b>236</b>	
JA5035	132	<b>237</b>	
JA5035	135	<b>243</b>	
JA5035	135	<b>244</b>	
JA5035	141	<b>253</b>	
JA5035	142	<b>254</b>	
JA5035	143	<b>255</b>	
JA5035	144	<b>256</b>	
JA5036	157	<b>270</b>	
JA5036	159	<b>272</b>	
JA5036	160	<b>273</b>	
JA5036	161	<b>274</b>	
JA5036	162	<b>275</b>	
JA5036	163	<b>276</b>	
JA5036	164	<b>277</b>	
JA5036	169	<b>289</b>	
JA5036	170	<b>290</b>	
JB841	330	<b>575</b>	
JB841	331	<b>576</b>	
JB851	330	<b>574</b>	
JC054	345	<b>612</b>	
JC054	347	<b>614</b>	
JC054	348	<b>615</b>	
JC054	348	<b>616</b>	
JC054	349	<b>617</b>	
JC054	351	<b>619</b>	
JC054	352	<b>620</b>	
JC054	353	<b>621</b>	
JC054	354	<b>622</b>	
JC054	354	<b>623</b>	

			<b>9</b>
JC054	355	<b>624</b>	
JC054	356	<b>625</b>	
JC054	357	<b>626</b>	
JC054	358	<b>628</b>	
JC054	358	<b>629</b>	
JC054	359	<b>630</b>	
JC054	360	<b>632</b>	
JC054	361	<b>633</b>	
JC054	362	<b>634</b>	
JC054	363	<b>635</b>	
JC054	363	<b>636</b>	
JC054	364	<b>637</b>	
JC054	364	<b>638</b>	
JC054	366	<b>640</b>	
JC054	367	<b>641</b>	
JC054	368	<b>642</b>	
JC054	368	<b>643</b>	
JC054	369	<b>645</b>	
JC054	370	<b>647</b>	
JC054	372	<b>650</b>	
JC054	372	<b>651</b>	
JC054	373	<b>652</b>	
JC054	374	<b>653</b>	
JC054	374	<b>654</b>	
JC054	375	<b>655</b>	
JC054	376	<b>658</b>	
JC054	377	<b>659</b>	
JC054	378	<b>660</b>	
JC054	379	<b>661</b>	
JC054	379	<b>662</b>	
JC054	380	<b>663</b>	
JC054	380	<b>664</b>	
JC054	381	<b>665</b>	
JC054	381	<b>666</b>	
JC054	382	<b>667</b>	
JC054	383	<b>668</b>	
JC054	384	<b>670</b>	
JC054	384	<b>671</b>	
JC054	385	<b>672</b>	
JC054	385	<b>673</b>	
JC054	386	<b>674</b>	
JC054	387	<b>675</b>	
JC054	388	<b>676</b>	
JC054	389	<b>677</b>	
JC054	389	<b>678</b>	
JC054	390	<b>679</b>	
JC054	391	<b>680</b>	
JC054	393	<b>682</b>	
JC054	394	<b>683</b>	
JC054	394	<b>684</b>	
JC054	405	<b>710</b>	
JC054	406	<b>711</b>	
JC054	409	<b>715</b>	
JC054	410	<b>717</b>	
JC054	411	<b>720</b>	
JC054	413	<b>724</b>	
JC054	414	<b>725</b>	
JC054	415	<b>727</b>	
JC054	416	<b>730</b>	
JC054	416	<b>731</b>	

			<b>9</b>
JC054	417	<b>732</b>	
JC054	417	<b>733</b>	
JC054	418	<b>734</b>	
JC054	419	<b>736</b>	
JC054	420	<b>737</b>	
JC055	345	<b>612</b>	
JC055	347	<b>614</b>	
JC055	349	<b>617</b>	
JC055	351	<b>619</b>	
JC055	352	<b>620</b>	
JC055	353	<b>621</b>	
JC055	354	<b>622</b>	
JC055	355	<b>624</b>	
JC055	357	<b>626</b>	
JC055	358	<b>628</b>	
JC055	359	<b>630</b>	
JC055	359	<b>631</b>	
JC055	361	<b>633</b>	
JC055	362	<b>634</b>	
JC055	363	<b>635</b>	
JC055	363	<b>636</b>	
JC055	364	<b>637</b>	
JC055	364	<b>638</b>	
JC055	367	<b>641</b>	
JC055	368	<b>642</b>	
JC055	368	<b>643</b>	
JC055	369	<b>645</b>	
JC055	370	<b>647</b>	
JC055	372	<b>650</b>	
JC055	372	<b>651</b>	
JC055	373	<b>652</b>	
JC055	374	<b>653</b>	
JC055	374	<b>654</b>	
JC055	375	<b>656</b>	
JC055	376	<b>658</b>	
JC055	378	<b>660</b>	
JC055	379	<b>661</b>	
JC055	379	<b>662</b>	
JC055	381	<b>666</b>	
JC055	383	<b>668</b>	
JC055	384	<b>670</b>	
JC055	384	<b>671</b>	
JC055	380	<b>663</b>	
JC055	380	<b>664</b>	
JC055	381	<b>666</b>	
JC055	383	<b>668</b>	
JC055	384	<b>670</b>	
JC055	384	<b>671</b>	
JC055	385	<b>672</b>	
JC055	386	<b>674</b>	
JC055	387	<b>675</b>	
JC055	388	<b>676</b>	
JC055	389	<b>677</b>	
JC055	389	<b>678</b>	
JC055	394	<b>683</b>	
JC055	394	<b>684</b>	
JC055	405	<b>710</b>	
JC055	406	<b>711</b>	
JC055	409	<b>715</b>	
JC055	392	<b>681</b>	
JC055	393	<b>682</b>	
JC055	394	<b>683</b>	
JC055	394	<b>684</b>	
JC055	405	<b>710</b>	
JC055	406	<b>711</b>	
JC055	409	<b>715</b>	
JC055	410	<b>717</b>	



		<b>9</b>
JC055	411	<b>720</b>
JC055	413	<b>724</b>
JC055	414	<b>725</b>
JC055	414	<b>726</b>
JC055	415	<b>727</b>
JC055	415	<b>728</b>
JC055	416	<b>730</b>
JC055	416	<b>731</b>
JC055	417	<b>732</b>
JC055	417	<b>733</b>
JC055	418	<b>734</b>
JC055	419	<b>736</b>
JC055	420	<b>737</b>
JC287	228	<b>384</b>
JC415	199	<b>330</b>
JC423	200	<b>331</b>
JC423	201	<b>333</b>
JC423	202	<b>334</b>
JC423	203	<b>336</b>
JC423	204	<b>338</b>
JC423	204	<b>339</b>
JC497	56	<b>107</b>
JC497	58	<b>112</b>
JC497	244	<b>415</b>
JC497	342	<b>606</b>
JC660	2	<b>2</b>
JC660	3	<b>3</b>
JC662	231	<b>390</b>
JC662	234	<b>398</b>
JC662	235	<b>399</b>
JC662	237	<b>402</b>
JC662	238	<b>403</b>
JC662	239	<b>404</b>
JC662	241	<b>409</b>
JC662	251	<b>435</b>
JC662	251	<b>436</b>
JC662	252	<b>437</b>
JC662	253	<b>438</b>
JC662	255	<b>441</b>
JC662	262	<b>453</b>
JC662	266	<b>457</b>
JC662	270	<b>464</b>
JC662	273	<b>469</b>
JC662	275	<b>472</b>
JC662	280	<b>480</b>
JC706	357	<b>626</b>
JC723	54	<b>102</b>
JC723	80	<b>164</b>
JC738	173	<b>296</b>
JC738	173	<b>297</b>
JC738	174	<b>298</b>
JC738	174	<b>299</b>
JC738	175	<b>300</b>
JC738	176	<b>301</b>
JC738	177	<b>302</b>
JC738	178	<b>303</b>
JC738	179	<b>304</b>
JC738	179	<b>305</b>
JC738	180	<b>306</b>
JC738	181	<b>307</b>

		<b>9</b>
JC738	183	<b>311</b>
JC738	184	<b>312</b>
JC738	185	<b>313</b>
JC738	186	<b>314</b>
JC738	187	<b>315</b>
JC738	188	<b>316</b>
JC738	188	<b>317</b>
JC738	189	<b>318</b>
JC738	190	<b>319</b>
JC738	191	<b>320</b>
JC738	192	<b>321</b>
JC738	193	<b>322</b>
JC738	194	<b>323</b>
JC738	195	<b>324</b>
JC738	196	<b>325</b>
JC738	197	<b>326</b>
JC759	200	<b>331</b>
JC759	203	<b>336</b>
JC928	331	<b>578</b>
JC928	332	<b>579</b>
JC928	341	<b>604</b>
JC928	341	<b>605</b>
JC928	342	<b>607</b>
JC928	344	<b>611</b>
JC973	2	<b>1</b>
JC973	3	<b>4</b>
JC973	4	<b>5</b>
JC973	4	<b>6</b>
JC973	5	<b>8</b>
JC973	6	<b>10</b>
JC973	6	<b>11</b>
JC973	7	<b>13</b>
JC973	7	<b>14</b>
JC973	8	<b>15</b>
JC973	9	<b>20</b>
JC973	47	<b>88</b>
JC973	55	<b>103</b>
JC991	203	<b>336</b>
JD013	181	<b>309</b>
JD013	182	<b>310</b>
JD014	328	<b>568</b>
JD014	328	<b>569</b>
JD015	213	<b>353</b>
JD015	216	<b>358</b>
JD015	217	<b>359</b>
JD015	243	<b>412</b>
JD015	245	<b>422</b>
JD015	280	<b>481</b>
JD018	76	<b>157</b>
JD018	76	<b>158</b>
JD018	244	<b>416</b>
JD019	234	<b>398</b>
JD019	238	<b>403</b>
JD019	239	<b>404</b>
JD019	241	<b>409</b>
JD019	251	<b>435</b>
JD019	255	<b>441</b>
JD019	275	<b>472</b>
JD019	280	<b>480</b>
JD021	81	<b>166</b>

		<b>9</b>
JD021	81	<b>167</b>
JD022	82	<b>168</b>
JD022	82	<b>169</b>
JD022	86	<b>175</b>
JD025	331	<b>578</b>
JD025	332	<b>579</b>
JD025	341	<b>604</b>
JD025	341	<b>605</b>
JD025	342	<b>607</b>
JD067	80	<b>165</b>
JD146	60	<b>118</b>
JD146	61	<b>119</b>
JD146	62	<b>121</b>
JD146	62	<b>122</b>
JD146	63	<b>123</b>
JD146	64	<b>124</b>
JD146	65	<b>125</b>
JD146	65	<b>126</b>
JD146	66	<b>127</b>
JD146	83	<b>171</b>
JD146	84	<b>172</b>
JD146	85	<b>173</b>
JD146	85	<b>174</b>
JD146	86	<b>176</b>
JD146	87	<b>177</b>
JD146	292	<b>506</b>
JD146	298	<b>519</b>
JD146	298	<b>520</b>
JD146	300	<b>522</b>
JD146	301	<b>523</b>
JD146	301	<b>524</b>
JD146	302	<b>526</b>
JD146	303	<b>527</b>
JD146	303	<b>528</b>
JD146	304	<b>529</b>
JD146	305	<b>530</b>
JD146	306	<b>532</b>
JD146	307	<b>533</b>
JD146	310	<b>538</b>
JD146	311	<b>539</b>
JD146	312	<b>541</b>
JD146	312	<b>542</b>
JD146	313	<b>543</b>
JD146	314	<b>545</b>
JD146	315	<b>547</b>
JD146	321	<b>558</b>
JD146	324	<b>561</b>
JD146	325	<b>562</b>
JD148	2	<b>2</b>
JD148	3	<b>3</b>
JD148	15	<b>35</b>
JD148	16	<b>36</b>
JD148	17	<b>37</b>
JD148	18	<b>38</b>
JD148	19	<b>39</b>
JD148	21	<b>41</b>
JD148	22	<b>43</b>
JD148	22	<b>44</b>
JD148	24	<b>47</b>
JD148	66	<b>128</b>

		<b>9</b>
JD150	25	<b>48</b>
JD150	26	<b>49</b>
JD150	27	<b>50</b>
JD150	29	<b>53</b>
JD150	29	<b>54</b>
JD150	30	<b>55</b>
JD150	30	<b>56</b>
JD151	236	<b>400</b>
JD151	254	<b>439</b>
JD151	255	<b>442</b>
JD151	256	<b>443</b>
JD151	261	<b>452</b>
JD151	268	<b>460</b>
JD151	271	<b>465</b>
JD151	272	<b>467</b>
JD151	276	<b>474</b>
JD151	277	<b>475</b>
JD151	278	<b>476</b>
JD151	279	<b>478</b>
JD151	281	<b>482</b>
JD151	296	<b>514</b>
JD152	256	<b>443</b>
JD152	276	<b>474</b>
JD153	236	<b>400</b>
JD153	254	<b>439</b>
JD153	255	<b>442</b>
JD153	268	<b>460</b>
JD153	271	<b>465</b>
JD153	272	<b>467</b>
JD153	277	<b>475</b>
JD153	278	<b>476</b>
JD153	279	<b>478</b>
JD153	296	<b>514</b>
JD198	80	<b>164</b>
JD198	80	<b>165</b>
JD221	222	<b>369</b>
JD221	222	<b>370</b>
JD221	232	<b>393</b>
JD221	326	<b>564</b>
JD221	326	<b>565</b>
JD221	77	<b>159</b>
JD222	78	<b>160</b>
JD222	78	<b>161</b>
JD222	79	<b>162</b>
JD222	79	<b>163</b>
JD222	337	<b>592</b>
JD222	340	<b>601</b>
JD222	395	<b>685</b>
JD222	396	<b>688</b>
JD222	396	<b>689</b>
JD222	397	<b>691</b>
JD223	337	<b>592</b>
JD223	337	<b>594</b>
JD223	340	<b>601</b>
JD223	396	<b>688</b>
JD223	396	<b>689</b>
JD223	397	<b>691</b>
JD224	77	<b>159</b>
JD224	78	<b>160</b>
JD224	78	<b>161</b>

# NUMERICAL PARTS LIST





Numerische Teilenummernliste • Elenco riferimenti  
Liste des références produits

		<b>9</b>
JD224	79	<b>162</b>
JD224	79	<b>163</b>
JD224	337	<b>593</b>
JD224	338	<b>595</b>
JD224	340	<b>601</b>
JD224	340	<b>602</b>
JD224	341	<b>603</b>
JD224	396	<b>688</b>
JD224	396	<b>689</b>
JD224	397	<b>690</b>
JD224	397	<b>691</b>
JD224	400	<b>697</b>
JD224	401	<b>698</b>
JD224	402	<b>701</b>
JD224	403	<b>705</b>
JD225	146	<b>258</b>
JD225	147	<b>259</b>
JD225	148	<b>260</b>
JD225	149	<b>261</b>
JD225	150	<b>262</b>
JD225	151	<b>263</b>
JD225	151	<b>264</b>
JD225	152	<b>265</b>
JD225	153	<b>266</b>
JD225	154	<b>267</b>
JD225	213	<b>354</b>
JD225	215	<b>356</b>
JD225	216	<b>357</b>
JD226	146	<b>258</b>
JD226	147	<b>259</b>
JD226	148	<b>260</b>
JD226	149	<b>261</b>
JD226	150	<b>262</b>
JD226	151	<b>263</b>
JD226	151	<b>264</b>
JD226	152	<b>265</b>
JD226	153	<b>266</b>
JD226	154	<b>267</b>
JD226	213	<b>354</b>
JD226	214	<b>355</b>
JD226	215	<b>356</b>
JD226	216	<b>357</b>
JD227	156	<b>269</b>
JD227	158	<b>271</b>
JD228	156	<b>269</b>
JD228	157	<b>270</b>
JD228	158	<b>271</b>
JD228	159	<b>272</b>
JD228	160	<b>273</b>
JD228	161	<b>274</b>
JD228	162	<b>275</b>
JD228	163	<b>276</b>
JD228	164	<b>277</b>
JD228	169	<b>289</b>
JD228	170	<b>290</b>
JD230	288	<b>499</b>
JD230	289	<b>500</b>
JD235	213	<b>353</b>
JD235	216	<b>358</b>
JD235	217	<b>359</b>

		<b>9</b>
JD235	243	<b>412</b>
JD235	280	<b>481</b>
JD271	93	<b>189</b>
JD271	94	<b>190</b>
JD271	95	<b>191</b>
JD271	95	<b>192</b>
JD271	96	<b>193</b>
JD271	97	<b>194</b>
JD271	98	<b>195</b>
JD271	99	<b>196</b>
JD271	100	<b>197</b>
JD271	101	<b>198</b>
JD271	102	<b>199</b>
JD271	105	<b>203</b>
JD271	106	<b>204</b>
JD271	107	<b>205</b>
JD271	108	<b>206</b>
JD271	207	<b>345</b>
JD271	208	<b>346</b>
JD271	208	<b>347</b>
JD271	209	<b>348</b>
JD271	210	<b>349</b>
JD271	212	<b>351</b>
JD271	212	<b>352</b>
JD273	92	<b>187</b>
JD273	93	<b>189</b>
JD273	94	<b>190</b>
JD273	95	<b>191</b>
JD273	95	<b>192</b>
JD273	96	<b>193</b>
JD273	97	<b>194</b>
JD273	98	<b>195</b>
JD273	99	<b>196</b>
JD273	100	<b>197</b>
JD273	101	<b>198</b>
JD273	102	<b>199</b>
JD273	103	<b>200</b>
JD273	104	<b>201</b>
JD273	104	<b>202</b>
JD273	105	<b>203</b>
JD273	106	<b>204</b>
JD273	107	<b>205</b>
JD273	108	<b>206</b>
JD273	138	<b>248</b>
JD273	139	<b>249</b>
JD273	140	<b>251</b>
JD273	140	<b>252</b>
JD273	206	<b>343</b>
JD273	206	<b>344</b>
JD273	207	<b>345</b>
JD273	208	<b>346</b>
JD273	208	<b>347</b>
JD273	209	<b>348</b>
JD273	210	<b>349</b>
JD273	212	<b>351</b>
JD273	212	<b>352</b>
JD340	319	<b>555</b>
JD340	319	<b>556</b>
JD340	320	<b>557</b>
JD342	90	<b>184</b>



		<b>9</b>
JD342	91	<b>185</b>
JD342	91	<b>186</b>
JD343	90	<b>184</b>
JD343	91	<b>185</b>
JD343	91	<b>186</b>
JD464	28	<b>51</b>
JD464	28	<b>52</b>
JD464	31	<b>57</b>
JD465	28	<b>51</b>
JD465	28	<b>52</b>
JD465	31	<b>57</b>
JD466	92	<b>187</b>
JD467	109	<b>208</b>
JD467	110	<b>209</b>
JD468	109	<b>208</b>
JD468	110	<b>209</b>
JD468	111	<b>210</b>
JD468	112	<b>211</b>
JD468	113	<b>212</b>
JD468	114	<b>213</b>
JD468	115	<b>214</b>
JD468	115	<b>215</b>
JD468	116	<b>216</b>
JD468	117	<b>217</b>
JD468	118	<b>218</b>
JD468	119	<b>219</b>
JD468	120	<b>220</b>
JD468	121	<b>221</b>
JD468	122	<b>222</b>
JD468	125	<b>226</b>
JD468	125	<b>227</b>
JD468	126	<b>228</b>
JD468	126	<b>229</b>
JD468	127	<b>230</b>
JD468	128	<b>231</b>
JD468	128	<b>232</b>
JD468	129	<b>233</b>
JD468	130	<b>235</b>
JD468	131	<b>236</b>
JD468	132	<b>237</b>
JD468	135	<b>243</b>
JD468	135	<b>244</b>
JD468	136	<b>246</b>
JD468	137	<b>247</b>
JD468	139	<b>250</b>
JD468	141	<b>253</b>
JD468	142	<b>254</b>
JD468	143	<b>255</b>
JD468	144	<b>256</b>
JD468	145	<b>257</b>
JD519	199	<b>330</b>
JD529	289	<b>500</b>
JD536	282	<b>485</b>
JD536	294	<b>511</b>
JD539	282	<b>485</b>
JD565	328	<b>568</b>
JD565	328	<b>569</b>
JD586	338	<b>597</b>
JD586	339	<b>598</b>
JD586	339	<b>599</b>



		<b>9</b>
JD586	398	<b>692</b>
JD586	398	<b>693</b>
JD586	399	<b>694</b>
JD586	400	<b>696</b>
JD586	404	<b>707</b>
JD586	404	<b>708</b>
JD586	405	<b>709</b>
JD587	338	<b>597</b>
JD587	339	<b>598</b>
JD587	339	<b>599</b>
JD587	398	<b>692</b>
JD587	398	<b>693</b>
JD587	399	<b>694</b>
JD587	400	<b>696</b>
JD587	404	<b>707</b>
JD587	404	<b>708</b>
JD587	405	<b>709</b>
JD5143	88	<b>180</b>
JD5143	89	<b>181</b>
JD5143	315	<b>548</b>
JD5143	316	<b>549</b>
JD5143	316	<b>550</b>
JD5143	317	<b>551</b>
JD5143	317	<b>552</b>
JD5143	318	<b>553</b>
JD5143	318	<b>554</b>
JD5143	319	<b>555</b>
JD5143	319	<b>556</b>
JD5143	320	<b>557</b>
JD5144	331	<b>578</b>
JD5144	332	<b>579</b>
JD5144	341	<b>604</b>
JD5144	341	<b>605</b>
JD5144	342	<b>606</b>
JD5144	342	<b>607</b>
JD5144	343	<b>608</b>
JD5144	343	<b>609</b>
JD5144	344	<b>610</b>
JD5144	344	<b>611</b>
JD5155	49	<b>91</b>
JD5155	49	<b>93</b>
JD5155	50	<b>94</b>
JD5155	51	<b>95</b>
JD5155	52	<b>96</b>
JD5155	53	<b>100</b>
JD5155	54	<b>101</b>
JD5155	65	<b>126</b>
JD5155	66	<b>127</b>
JD5155	299	<b>521</b>
JD5190	285	<b>493</b>
JD5190	285	<b>494</b>
JD5190	287	<b>497</b>
JD5190	288	<b>498</b>
JD5191	287	<b>497</b>
JD5191	288	<b>498</b>
JD5192	172	<b>294</b>
JD5291	285	<b>494</b>
JD5291	288	<b>499</b>
JD5337	332	<b>580</b>
JD5337	333	<b>581</b>



 <b>9</b>			 <b>9</b>			 <b>9</b>			 <b>9</b>		
JD5337	333	582	JD5411	14	30	JE390	224	375	JF145	25	48
JD5337	334	583	JD5411	14	31	JE390	226	378	JF145	26	49
JD5337	334	585	JD5411	14	32	JE390	279	479	JF145	27	50
JD5337	335	586	JD5411	15	33	JE390	292	506	JF145	29	53
JD5337	336	588	JD5413	10	22	JE390	298	519	JF145	29	54
JD5337	336	589	JD5413	11	25	JE390	298	520	JF145	30	55
JD5337	337	591	JD5413	12	26	JE390	300	522	JF145	30	56
JD5337	350	618	JD5413	12	27	JE390	302	526	JF145	32	58
JD5338	332	580	JD5413	13	28	JE390	303	527	JF145	66	128
JD5338	333	581	JD5413	13	29	JE390	303	528	JF150	84	172
JD5338	333	582	JD5413	14	30	JE390	304	529	JF150	85	173
JD5338	334	583	JD5413	14	31	JE390	305	530	JF150	85	174
JD5338	334	585	JD5413	14	32	JE390	306	532	JF150	86	176
JD5338	335	586	JD5413	15	33	JE390	307	533	JF150	87	177
JD5338	336	588	JD5810	170	290	JE390	310	538	JF150	313	543
JD5338	336	589	JD5829	47	86	JE390	311	539	JF150	321	558
JD5338	337	591	JD5868	297	517	JE480	10	21	JF150	325	562
JD5338	350	618	JD5868	297	518	JE480	46	83	JF184	28	51
JD5375	15	35	JD5881	283	489	JE480	54	102	JF184	28	52
JD5375	16	36	JD5881	284	490	JE647	331	576	JF184	31	57
JD5375	17	37	JD5881	284	492	JE696	56	107	JH111	503	896
JD5375	18	38	JD5881	286	495	JE696	58	112	JH111	605	1055
JD5375	19	39	JD5906	329	571	JE696	68	132	JH111	606	1056
JD5375	20	40	JD5906	329	572	JE696	76	157	JH111	607	1058
JD5375	21	41	JD5907	329	571	JE696	76	158	JH111	608	1059
JD5375	22	43	JD5907	329	572	JE696	244	417	JH111	608	1060
JD5375	22	44	JD5965	58	111	JE696	245	422	JH111	611	1064
JD5375	23	45	JD5972	201	333	JE744	69	137	JH111	612	1065
JD5375	23	46	JD5972	202	334	JE744	70	138	JH111	615	1068
JD5375	24	47	JD5972	204	339	JE744	70	139	JH111	616	1069
JD5375	25	48	JD5981	421	742	JE744	71	140	JH111	617	1073
JD5375	26	49	JD5981	422	743	JE744	71	141	JH111	626	1087
JD5375	27	50	JD5981	422	744	JE744	225	377	JH111	640	1110
JD5375	29	53	JD5981	422	745	JE744	326	564	JH111	652	1127
JD5375	29	54	JD5981	423	746	JE744	326	565	JH111	653	1128
JD5375	30	55	JD5981	423	747	JE744	327	566	JH111	654	1129
JD5375	30	56	JD5982	89	182	JF123	331	578	JH111	656	1131
JD5375	32	58	JD5993	12	27	JF123	332	579	JH111	669	1144
JD5375	33	59	JD5993	13	28	JF123	341	605	JH111	669	1145
JD5375	36	62	JD5993	13	29	JF123	342	607	JH111	671	1148
JD5375	37	63	JD5997	230	387	JF123	347	614	JH310	440	772
JD5375	38	64	JD5997	236	400	JF123	349	617	JH310	468	831
JD5375	42	74	JD5997	260	451	JF123	370	647	JH310	478	850
JD5375	43	76	JD5997	261	452	JF123	372	650	JH310	479	851
JD5375	66	128	JD5997	268	460	JF123	378	660	JH494	488	871
JD5376	123	223	JD5997	268	461	JF123	385	672	JH494	490	873
JD5376	124	224	JD5997	272	466	JF123	413	724	JH494	491	874
JD5376	132	238	JD5997	272	467	JF123	416	731	JH494	685	1172
JD5376	133	239	JD5997	273	468	JF123	419	736	JH494	694	1184
JD5376	133	240	JD5997	277	475	JF123	420	737	JH494	698	1191
JD5376	134	241	JD5997	278	476	JF145	15	35	JH494	700	1194
JD5376	134	242	JD5997	279	478	JF145	16	36	JH494	701	1196
JD5376	136	245	JD6023	171	292	JF145	17	37	JH565	493	878
JD5376	138	248	JD6023	171	293	JF145	18	38	JH565	494	880
JD5376	139	249	JD6023	172	294	JF145	19	39	JH565	495	882
JD5376	140	251	JE390	60	118	JF145	20	40	JH565	497	885
JD5376	140	252	JE390	61	119	JF145	21	41	JH565	601	1048
JD5411	10	22	JE390	72	144	JF145	22	43	JH565	601	1049
JD5411	11	25	JE390	223	371	JF145	22	44	JH565	604	1053
JD5411	12	26	JE390	223	372	JF145	24	47	JH565	713	1216



# NUMERICAL PARTS LIST

Numerische Teilenummernliste • Elenco riferimenti  
 Liste des références produits

				
JH565	714	1217		
JH565	716	1220		
JH565	717	1221		
JH5077	721	1229		
JH5077	723	1232		
JH5077	724	1233		
JH5077	724	1235		
JH5077	725	1236		
JH5077	743	1260		
JH5178	733	1252		
JH5178	741	1258		
JH5178	766	1275		
JH5178	770	1278		
JH5178	778	1283		
JH5178	779	1284		
JH5178	788	1291		
JH5178	790	1292		
JH5178	790	1293		
JH5178	797	1297		
JH5178	798	1298		
JH5178	802	1302		
JH5178	817	1313		
JH5178	819	1314		
JH5178	833	1331		
JH5178	842	1342		
JH5178	844	1344		
JH5178	845	1345		
JJ078	473	841		
JJ078	474	844		
JJ078	475	845		
JJ078	477	849		
JJ078	491	875		
JJ078	695	1185		
JJ100	731	1250		
JJ100	735	1253		
JJ100	738	1255		
JJ100	745	1261		
JJ100	747	1262		
JJ100	749	1263		
JJ100	753	1265		
JJ100	755	1266		
JJ100	757	1268		
JJ100	760	1270		
JJ100	767	1276		
JJ100	783	1288		
JJ100	792	1294		
JJ100	799	1299		
JJ100	804	1305		
JJ100	821	1316		
JJ100	822	1317		
JJ100	822	1318		
JJ100	827	1321		
JJ136	583	1016		
JJ136	584	1018		
JJ283	585	1021		
JJ283	585	1022		
JJ283	587	1024		
JJ283	588	1025		
JJ283	589	1026		
JJ283	590	1027		

				
JJ283	590	1028		
JJ283	591	1029		
JJ283	681	1166		
JJ283	682	1167		
JJ283	687	1175		
JJ283	687	1176		
JJ283	690	1179		
JJ298	480	853		
JJ298	561	993		
JJ298	563	994		
JJ298	564	995		
JJ298	564	996		
JJ298	565	997		
JJ298	566	998		
JJ298	568	1000		
JJ298	569	1001		
JJ298	570	1002		
JJ298	571	1003		
JJ298	573	1006		
JJ298	574	1007		
JJ298	575	1008		
JJ298	576	1009		
JJ298	578	1010		
JJ298	579	1011		
JJ298	580	1012		
JJ298	581	1013		
JJ298	582	1014		
JJ298	614	1067		
JJ298	616	1070		
JJ298	617	1072		
JJ298	622	1080		
JJ298	639	1109		
JJ298	643	1114		
JJ298	644	1115		
JJ298	650	1123		
JJ298	655	1130		
JJ298	657	1132		
JJ298	658	1133		
JJ298	659	1134		
JJ298	665	1140		
JJ298	705	1203		
JJ317	762	1271		
JJ317	809	1308		
JJ398	480	853		
JJ398	561	993		
JJ398	563	994		
JJ398	564	996		
JJ398	565	997		
JJ398	566	998		
JJ398	568	1000		
JJ398	569	1001		
JJ398	570	1002		
JJ398	573	1006		
JJ398	576	1009		
JJ398	578	1010		
JJ398	579	1011		
JJ398	580	1012		
JJ398	581	1013		
JJ413	612	1065		
JJ413	622	1081		

				
JJ413	624	1085		
JJ413	626	1089		
JJ413	627	1090		
JJ413	643	1114		
JJ413	644	1115		
JJ413	645	1116		
JJ413	646	1117		
JJ413	647	1119		
JJ413	648	1121		
JJ413	650	1124		
JJ413	651	1125		
JJ413	658	1133		
JJ413	662	1137		
JJ413	663	1138		
JJ413	666	1141		
JJ413	667	1142		
JJ413	668	1143		
JJ413	670	1147		
JJ413	672	1150		
JJ413	673	1152		
JJ413	705	1203		
JJ440	476	846		
JJ449	426	749		
JJ449	435	763		
JJ450	604	1054		
JJ450	618	1074		
JJ451	671	1149		
JJ452	480	854		
JJ452	483	859		
JJ452	505	899		
JJ452	506	900		
JJ452	633	1100		
JJ452	634	1101		
JJ452	636	1105		
JJ452	637	1106		
JJ452	729	1246		
JJ453	510	909		
JJ453	511	910		
JJ453	512	911		
JJ453	513	912		
JJ453	514	913		
JJ453	514	914		
JJ453	515	915		
JJ453	695	1186		
JJ453	697	1188		
JJ453	700	1193		
JJ453	701	1196		
JJ453	702	1197		
JJ453	703	1199		
JJ453	703	1200		
JJ453	704	1201		
JJ453	705	1202		
JJ453	706	1204		
JJ453	708	1208		
JJ453	710	1210		
JJ453	710	1211		
JJ453	711	1212		
JJ453	711	1213		
JJ453	713	1215		
JJ471	507	904		

				
JJ471	508	905		
JJ515	830	1325		
JJ519	731	1250		
JJ519	733	1252		
JJ519	735	1253		
JJ519	738	1255		
JJ519	741	1258		
JJ519	742	1259		
JJ519	745	1261		
JJ519	751	1264		
JJ519	757	1268		
JJ519	766	1275		
JJ519	770	1278		
JJ519	773	1280		
JJ519	776	1282		
JJ519	778	1283		
JJ519	779	1284		
JJ519	780	1285		
JJ519	781	1286		
JJ519	782	1287		
JJ519	783	1288		
JJ519	788	1291		
JJ519	790	1292		
JJ519	790	1293		
JJ519	794	1295		
JJ519	797	1297		
JJ519	798	1298		
JJ519	801	1301		
JJ519	802	1302		
JJ519	803	1303		
JJ519	804	1305		
JJ519	806	1306		
JJ519	812	1310		
JJ519	814	1311		
JJ519	822	1318		
JJ519	827	1321		
JJ519	832	1329		
JJ519	833	1331		
JJ519	835	1333		
JJ605	430	755		
JJ605	430	756		
JJ605	435	763		
JJ613	837	1335		
JJ613	838	1336		
JJ613	839	1337		
JJ613	840	1339		
JJ613	841	1341		
JJ613	842	1342		
JJ613	843	1343		
JJ613	845	1345		
JM085	72	143		
JM085	72	146		
JM085	72	147		
JM085	73	148		
JM085	73	149		
JM085	73	150		
JM085	74	151		
JM085	223	373		
JM085	224	374		
JM085	224	375		

			<b>9</b>
JM085	225	<b>376</b>	
JM085	226	<b>378</b>	
JM085	226	<b>379</b>	
JM085	233	<b>396</b>	
JM085	233	<b>397</b>	
JM085	247	<b>427</b>	
JM085	247	<b>428</b>	
JM085	248	<b>430</b>	
JM085	248	<b>431</b>	
JM085	248	<b>432</b>	
JM085	249	<b>433</b>	
JM333	2	<b>1</b>	
JM333	5	<b>8</b>	
JM333	6	<b>10</b>	
JM333	6	<b>11</b>	
JM333	7	<b>13</b>	
JM333	9	<b>20</b>	
JM333	47	<b>88</b>	
JM490	10	<b>21</b>	
JM490	46	<b>83</b>	
JM508	73	<b>149</b>	
JM508	223	<b>373</b>	
JM508	224	<b>374</b>	
JM508	225	<b>376</b>	
JM508	225	<b>377</b>	
JM508	226	<b>378</b>	
JM508	226	<b>379</b>	
JM508	233	<b>396</b>	
JM663	60	<b>118</b>	
JM663	61	<b>119</b>	
JM663	61	<b>120</b>	
JM663	81	<b>166</b>	
JM663	81	<b>167</b>	
JM663	257	<b>445</b>	
JM663	292	<b>506</b>	
JM663	292	<b>507</b>	
JM663	298	<b>519</b>	
JM663	298	<b>520</b>	
JM663	301	<b>524</b>	
JM663	303	<b>527</b>	
JM663	303	<b>528</b>	
JM663	306	<b>532</b>	
JM663	310	<b>537</b>	
JM674	10	<b>21</b>	
JM674	46	<b>83</b>	
JM674	54	<b>102</b>	
JM674	55	<b>103</b>	
JM5002	93	<b>189</b>	
JM5002	94	<b>190</b>	
JM5002	95	<b>191</b>	
JM5002	105	<b>203</b>	
JM5002	106	<b>204</b>	
JM5002	208	<b>346</b>	
JM5002	208	<b>347</b>	
JM5002	209	<b>348</b>	
JM5002	210	<b>349</b>	
JM5002	211	<b>350</b>	
JM5003	117	<b>217</b>	
JM5003	127	<b>230</b>	
JM5018	149	<b>261</b>	

			<b>9</b>
JM5018	150	<b>262</b>	
JM5018	151	<b>263</b>	
JM5018	151	<b>264</b>	
JM5018	152	<b>265</b>	
JM5018	154	<b>267</b>	
JM5018	213	<b>354</b>	
JM5019	20	<b>40</b>	
JM5019	29	<b>53</b>	
JM5019	29	<b>54</b>	
JM5019	30	<b>55</b>	
JM5019	30	<b>56</b>	
JM5019	32	<b>58</b>	
JM5019	33	<b>59</b>	
JM5019	37	<b>63</b>	
JM5023	77	<b>159</b>	
JM5023	78	<b>160</b>	
JM5023	397	<b>691</b>	
JM5024	77	<b>159</b>	
JM5024	78	<b>160</b>	
JM5024	397	<b>691</b>	
JM5028	112	<b>211</b>	
JM5028	113	<b>212</b>	
JM5028	114	<b>213</b>	
JM5028	115	<b>214</b>	
JM5028	116	<b>216</b>	
JM5028	118	<b>218</b>	
JM5028	119	<b>219</b>	
JM5028	120	<b>220</b>	
JM5028	121	<b>221</b>	
JM5028	122	<b>222</b>	
JM5028	125	<b>226</b>	
JM5028	128	<b>231</b>	
JM5028	128	<b>232</b>	
JM5028	129	<b>233</b>	
JM5028	130	<b>235</b>	
JM5028	131	<b>236</b>	
JM5028	132	<b>237</b>	
JM5028	135	<b>244</b>	
JM5028	143	<b>255</b>	
JM5028	144	<b>256</b>	
JM5029	161	<b>274</b>	
JM5029	162	<b>275</b>	
JM5029	163	<b>276</b>	
JM5029	164	<b>277</b>	
JM5087	285	<b>493</b>	
JM5087	285	<b>494</b>	
JM5087	287	<b>497</b>	
JM5088	172	<b>294</b>	
JM5089	172	<b>294</b>	
JM5139	282	<b>485</b>	
JM5141	286	<b>495</b>	
JM5141	286	<b>496</b>	
JM5141	291	<b>504</b>	
JM5141	291	<b>505</b>	
JM5176	28	<b>51</b>	
JM5176	28	<b>52</b>	
JM5176	31	<b>57</b>	
JM5176	34	<b>60</b>	
JM5176	35	<b>61</b>	
JM5176	38	<b>65</b>	

			<b>9</b>
JM5176	39	<b>66</b>	
JM5176	39	<b>67</b>	
JM5176	40	<b>68</b>	
JM5176	40	<b>69</b>	
JM5176	41	<b>70</b>	
JM5176	41	<b>72</b>	
JM5176	42	<b>73</b>	
JM5176	44	<b>77</b>	
JM5201	332	<b>580</b>	
JM5201	333	<b>582</b>	
JM5201	334	<b>583</b>	
JM5201	335	<b>586</b>	
JM5201	336	<b>588</b>	
JM5201	350	<b>618</b>	
JM5202	332	<b>580</b>	
JM5202	333	<b>582</b>	
JM5202	334	<b>583</b>	
JM5202	334	<b>585</b>	
JM5202	335	<b>586</b>	
JM5202	336	<b>588</b>	
JM5202	336	<b>589</b>	
JM5202	337	<b>591</b>	
JM5204	112	<b>211</b>	
JM5204	113	<b>212</b>	
JM5204	114	<b>213</b>	
JM5204	115	<b>214</b>	
JM5204	115	<b>215</b>	
JM5204	116	<b>216</b>	
JM5204	118	<b>218</b>	
JM5204	119	<b>219</b>	
JM5204	120	<b>220</b>	
JM5204	121	<b>221</b>	
JM5204	122	<b>222</b>	
JM5204	125	<b>226</b>	
JM5204	125	<b>227</b>	
JM5204	126	<b>228</b>	
JM5204	126	<b>229</b>	
JM5204	128	<b>231</b>	
JM5204	128	<b>232</b>	
JM5204	129	<b>233</b>	
JM5204	130	<b>235</b>	
JM5204	131	<b>236</b>	
JM5204	132	<b>237</b>	
JM5204	135	<b>243</b>	
JM5204	135	<b>244</b>	
JM5204	136	<b>246</b>	
JM5204	137	<b>247</b>	
JM5204	139	<b>250</b>	
JM5204	143	<b>255</b>	
JM5204	144	<b>256</b>	
JM5204	145	<b>257</b>	
JM5259	10	<b>22</b>	
JM5259	11	<b>24</b>	
JM5259	11	<b>25</b>	
JM5259	12	<b>27</b>	
JM5259	13	<b>28</b>	
JM5259	13	<b>29</b>	
JM5259	14	<b>30</b>	
JM5259	14	<b>31</b>	
JM5259	14	<b>32</b>	

			<b>9</b>
JM5259	15	<b>33</b>	
JM5283	282	<b>485</b>	
JM5299	12	<b>26</b>	
JM7034	47	<b>86</b>	
JM7055	123	<b>223</b>	
JM7055	124	<b>224</b>	
JM7055	132	<b>238</b>	
JM7055	133	<b>239</b>	
JM7055	133	<b>240</b>	
JM7055	134	<b>241</b>	
JM7055	134	<b>242</b>	
JM7055	136	<b>245</b>	
JM7055	138	<b>248</b>	
JM7055	139	<b>249</b>	
JM7055	140	<b>251</b>	
JM7055	140	<b>252</b>	
JM7099	23	<b>45</b>	
JM7099	23	<b>46</b>	
JM7099	32	<b>58</b>	
JM7099	33	<b>59</b>	
JM7099	36	<b>62</b>	
JM7099	42	<b>74</b>	
JM7099	43	<b>76</b>	
JM7102	297	<b>517</b>	
JM7103	89	<b>182</b>	
JM7117	164	<b>278</b>	
JM7117	165	<b>279</b>	
JM7117	165	<b>280</b>	
JM7117	165	<b>281</b>	
JM7117	166	<b>282</b>	
JM7117	166	<b>283</b>	
JM7117	166	<b>284</b>	
JM7117	167	<b>285</b>	
JM7117	167	<b>286</b>	
JM7117	168	<b>287</b>	
JM7117	168	<b>288</b>	
JM7121	294	<b>511</b>	
JM7121	295	<b>512</b>	
JN244	330	<b>574</b>	
JN244	330	<b>575</b>	
JN244	331	<b>576</b>	
JN283	47	<b>88</b>	
JN283	48	<b>89</b>	
JN283	48	<b>90</b>	
JN283	53	<b>100</b>	
JN283	65	<b>125</b>	
JN283	65	<b>126</b>	
JN283	66	<b>127</b>	
JN283	299	<b>521</b>	
JN333	3	<b>4</b>	
JN406	8	<b>16</b>	
JN406	9	<b>17</b>	
JN406	9	<b>18</b>	
JN459	56	<b>106</b>	
JN459	173	<b>296</b>	
JN459	173	<b>297</b>	
JN459	174	<b>298</b>	
JN459	174	<b>299</b>	
JN459	175	<b>300</b>	
JN459	176	<b>301</b>	

# NUMERICAL PARTS LIST

Numerische Teilenummernliste • Elenco riferimenti  
Liste des références produits

 <b>9</b>		
JN459	177	302
JN459	178	303
JN459	179	304
JN459	179	305
JN459	180	306
JN459	181	307
JN459	183	311
JN459	184	312
JN459	185	313
JN459	186	314
JN459	187	315
JN459	188	316
JN459	188	317
JN459	189	318
JN459	190	319
JN459	191	320
JN459	194	323
JN459	195	324
JN459	196	325
JN459	197	326
JN459	224	375
JN462	345	612
JN462	353	621
JN462	358	628
JN462	381	666
JN462	390	679
JN462	394	684
JN544	200	331
JN544	200	332
JN544	201	333
JN544	202	334
JN544	203	336
JN544	204	339
JN547	199	330
JN547	293	509
JN547	296	514
JN568	192	321
JN568	193	322
JN581	341	604
JN585	361	633
JN585	362	634
JN585	382	667
JN585	383	668
JN585	384	670
JN585	391	680
JN585	392	681
JN587	49	91
JN588	67	130
JN588	67	131
JN588	68	132
JN588	69	136
JN588	69	137
JN588	70	138
JN588	71	140
JN588	217	360
JN588	218	361
JN588	219	363
JN588	219	364
JN588	221	367
JN588	222	369

 <b>9</b>		
JN588	222	370
JN588	232	393
JN594	345	612
JN594	347	614
JN594	348	615
JN594	348	616
JN594	349	617
JN594	351	619
JN594	352	620
JN594	353	621
JN594	354	622
JN594	355	624
JN594	356	625
JN594	357	626
JN594	358	628
JN594	359	630
JN594	359	631
JN594	363	635
JN594	364	637
JN594	364	638
JN594	367	641
JN594	368	642
JN594	368	643
JN594	369	645
JN594	372	650
JN594	372	651
JN594	373	652
JN594	374	653
JN594	374	654
JN594	375	656
JN594	376	658
JN594	378	660
JN594	380	663
JN594	380	664
JN594	381	666
JN594	384	671
JN594	385	672
JN594	386	674
JN594	389	678
JN596	388	676
JN596	405	710
JN643	225	377
JN643	231	390
JN643	234	398
JN643	237	402
JN643	250	434
JN643	251	435
JN643	251	436
JN643	252	437
JN643	253	438
JN643	262	453
JN643	266	457
JN643	270	464
JN643	275	472
JN643	280	480
JN643	314	546
JN644	227	381
JN645	231	390
JN658	46	85
JN666	80	164

 <b>9</b>		
JN667	2	2
JN667	3	3
JN667	15	35
JN667	16	36
JN667	17	37
JN667	18	38
JN667	19	39
JN667	21	41
JN667	22	43
JN667	22	44
JN667	24	47
JN667	25	48
JN667	26	49
JN667	27	50
JN667	29	53
JN667	29	54
JN667	30	55
JN667	30	56
JN667	38	64
JN667	66	128
JN669	50	94
JN669	51	95
JN669	52	96
JN803	4	5
JN803	4	6
JN803	7	14
JN803	8	15
JN804	80	165
JN805	60	118
JN805	61	119
JN805	61	120
JN805	62	121
JN805	62	122
JN805	63	123
JN805	64	124
JN805	65	125
JN805	65	126
JN805	81	166
JN805	81	167
JN805	82	168
JN805	82	169
JN805	83	170
JN805	83	171
JN805	84	172
JN805	85	173
JN805	85	174
JN805	86	175
JN805	86	176
JN805	87	177
JN805	87	178
JN805	292	506
JN805	292	507
JN805	298	519
JN805	298	520
JN805	300	522
JN805	301	523
JN805	302	526
JN805	303	527
JN805	303	528
JN805	304	529

 <b>9</b>		
JN805	305	530
JN805	305	531
JN805	306	532
JN805	307	533
JN805	309	535
JN805	310	538
JN805	311	539
JN805	311	540
JN805	312	541
JN805	312	542
JN805	313	543
JN805	313	544
JN805	314	546
JN805	315	547
JN805	321	558
JN805	322	559
JN805	323	560
JN805	324	561
JN805	325	562
JN806	75	156
JN806	76	157
JN806	76	158
JN806	244	416
JN807	77	159
JN807	78	160
JN807	78	161
JN807	79	162
JN807	79	163
JN807	337	592
JN807	337	594
JN807	340	601
JN807	395	685
JN807	396	688
JN807	396	689
JN808	77	159
JN808	78	160
JN808	78	161
JN808	79	162
JN808	79	163
JN808	337	592
JN808	337	594
JN808	340	601
JN808	395	685
JN808	396	688
JN808	396	689
JN809	182	310
JN810	328	568
JN810	328	569
JN811	328	568
JN811	328	569
JN812	244	417
JN812	245	422
JN813	401	700
JN814	401	700
JN819	234	398
JN928	236	400
JN928	254	439
JN928	255	442
JN928	256	443
JN928	261	452

			<b>9</b>
JN928	268	<b>460</b>	
JN928	271	<b>465</b>	
JN928	272	<b>467</b>	
JN928	276	<b>474</b>	
JN928	277	<b>475</b>	
JN928	278	<b>476</b>	
JN928	279	<b>478</b>	
JN928	281	<b>482</b>	
JN933	146	<b>258</b>	
JN933	147	<b>259</b>	
JN933	148	<b>260</b>	
JN933	153	<b>266</b>	
JN933	214	<b>355</b>	
JN934	156	<b>269</b>	
JN934	158	<b>271</b>	
JN940	213	<b>353</b>	
JN940	216	<b>358</b>	
JN940	217	<b>359</b>	
JN940	243	<b>412</b>	
JN940	280	<b>481</b>	
JN948	234	<b>398</b>	
JN948	235	<b>399</b>	
JN948	237	<b>402</b>	
JN948	238	<b>403</b>	
JN948	241	<b>409</b>	
JN948	266	<b>457</b>	
JN948	270	<b>464</b>	
JN956	385	<b>672</b>	
JN956	386	<b>674</b>	
JN956	387	<b>675</b>	
JN956	388	<b>676</b>	
JN956	409	<b>715</b>	
JN956	410	<b>717</b>	
JN956	411	<b>720</b>	
JN956	413	<b>724</b>	
JN956	414	<b>725</b>	
JN956	414	<b>726</b>	
JN956	415	<b>727</b>	
JN956	416	<b>730</b>	
JN956	417	<b>732</b>	
JN956	419	<b>736</b>	
JN969	393	<b>682</b>	
JN969	394	<b>683</b>	
JN972	90	<b>184</b>	
JN972	91	<b>185</b>	
JN972	91	<b>186</b>	
JN973	88	<b>180</b>	
JN973	89	<b>181</b>	
JN973	315	<b>548</b>	
JN973	316	<b>549</b>	
JN973	316	<b>550</b>	
JN973	317	<b>551</b>	
JN973	317	<b>552</b>	
JN973	318	<b>553</b>	
JN973	318	<b>554</b>	
JN973	319	<b>555</b>	
JN973	319	<b>556</b>	
JN973	320	<b>557</b>	
JP004	56	<b>107</b>	
JP004	58	<b>112</b>	

			<b>9</b>
JP019	109	<b>208</b>	
JP019	110	<b>209</b>	
JP024	314	<b>545</b>	
JP045	288	<b>499</b>	
JP049	62	<b>121</b>	
JP049	62	<b>122</b>	
JP049	63	<b>123</b>	
JP049	64	<b>124</b>	
JP049	65	<b>125</b>	
JP049	65	<b>126</b>	
JP049	82	<b>168</b>	
JP049	82	<b>169</b>	
JP049	83	<b>170</b>	
JP049	83	<b>171</b>	
JP049	84	<b>172</b>	
JP049	85	<b>173</b>	
JP049	85	<b>174</b>	
JP049	86	<b>175</b>	
JP049	86	<b>176</b>	
JP049	87	<b>177</b>	
JP049	87	<b>178</b>	
JP049	300	<b>522</b>	
JP049	302	<b>526</b>	
JP049	304	<b>529</b>	
JP049	305	<b>530</b>	
JP049	305	<b>531</b>	
JP049	306	<b>532</b>	
JP049	307	<b>533</b>	
JP049	309	<b>535</b>	
JP049	310	<b>538</b>	
JP049	311	<b>539</b>	
JP049	311	<b>540</b>	
JP049	312	<b>541</b>	
JP049	312	<b>542</b>	
JP049	313	<b>543</b>	
JP049	313	<b>544</b>	
JP049	314	<b>546</b>	
JP049	315	<b>547</b>	
JP049	321	<b>558</b>	
JP049	322	<b>559</b>	
JP049	323	<b>560</b>	
JP049	324	<b>561</b>	
JP049	325	<b>562</b>	
JP063	111	<b>210</b>	
JP063	141	<b>253</b>	
JP063	142	<b>254</b>	
JP064	157	<b>270</b>	
JP064	159	<b>272</b>	
JP064	160	<b>273</b>	
JP064	170	<b>290</b>	
JP068	343	<b>608</b>	
JP068	343	<b>609</b>	
JP068	344	<b>610</b>	
JP068	401	<b>700</b>	
JP069	416	<b>731</b>	
JP069	417	<b>733</b>	
JP069	420	<b>737</b>	
JP070	338	<b>597</b>	
JP070	339	<b>598</b>	
JP070	339	<b>599</b>	

			<b>9</b>
JP070	395	<b>687</b>	
JP070	398	<b>692</b>	
JP070	398	<b>693</b>	
JP070	399	<b>694</b>	
JP070	400	<b>696</b>	
JP070	404	<b>707</b>	
JP070	404	<b>708</b>	
JP070	405	<b>709</b>	
JP071	338	<b>597</b>	
JP071	339	<b>598</b>	
JP071	339	<b>599</b>	
JP071	395	<b>687</b>	
JP071	398	<b>692</b>	
JP071	398	<b>693</b>	
JP071	399	<b>694</b>	
JP071	400	<b>696</b>	
JP071	404	<b>707</b>	
JP071	404	<b>708</b>	
JP071	405	<b>709</b>	
KG393	10	<b>21</b>	
KG393	46	<b>83</b>	
KG393	54	<b>102</b>	
KG393	55	<b>103</b>	
KG5157	680	<b>1165</b>	
KG5337	297	<b>517</b>	
KG5337	297	<b>518</b>	
KV086	633	<b>1100</b>	
KV086	634	<b>1101</b>	
KV086	726	<b>1239</b>	
KV086	729	<b>1246</b>	
KV086	831	<b>1328</b>	
KV102	244	<b>416</b>	
LB414	227	<b>380</b>	
LB414	227	<b>381</b>	
LB414	250	<b>434</b>	
LB414	251	<b>436</b>	
LB414	253	<b>438</b>	
LB414	262	<b>453</b>	
LB414	270	<b>464</b>	
LK5001	460	<b>810</b>	
LK5001	460	<b>811</b>	
LK5001	461	<b>812</b>	
LK5001	461	<b>813</b>	
LK5001	462	<b>814</b>	
LK5001	462	<b>815</b>	
LK5001	463	<b>816</b>	
LK5001	463	<b>817</b>	
LK5001	464	<b>818</b>	
LK5001	465	<b>820</b>	
LK5001	465	<b>821</b>	
LK5001	465	<b>822</b>	
LK5001	466	<b>826</b>	
LK5001	467	<b>827</b>	
LK5001	467	<b>829</b>	
LS856	743	<b>1260</b>	
LT439	81	<b>166</b>	
LT439	81	<b>167</b>	
LT439	82	<b>168</b>	
LT439	82	<b>169</b>	
N151/6	640	<b>1110</b>	

			<b>9</b>
N151/6	675	<b>1155</b>	
N151/6	676	<b>1156</b>	
N151/6	677	<b>1159</b>	
N151/6	677	<b>1160</b>	
N151/6	678	<b>1161</b>	
N151/6	678	<b>1162</b>	
N151/6	679	<b>1163</b>	
N151/6	680	<b>1164</b>	
N151/6	680	<b>1165</b>	
N151/6	683	<b>1168</b>	
N151/6	683	<b>1169</b>	
N151/6	684	<b>1170</b>	
N151/6	685	<b>1171</b>	
N153/3	846	<b>1346</b>	
N153/3	847	<b>1347</b>	
NA784	502	<b>895</b>	
NA784	503	<b>896</b>	
NA5001	395	<b>686</b>	
NA5001	400	<b>697</b>	
NA5001	404	<b>707</b>	
NA5001	404	<b>708</b>	
NA5001	405	<b>709</b>	
NA5030	692	<b>1182</b>	
NA5031	692	<b>1182</b>	
NA5035	281	<b>483</b>	
NA5035	283	<b>488</b>	
NA5035	283	<b>489</b>	
NA5035	284	<b>490</b>	
NA5035	284	<b>491</b>	
NA5035	285	<b>493</b>	
NA5035	285	<b>494</b>	
NA5035	286	<b>495</b>	
NA5035	286	<b>496</b>	
NA5035	287	<b>497</b>	
NA5035	288	<b>498</b>	
NA5035	289	<b>501</b>	
NA5035	290	<b>502</b>	
NA5035	290	<b>503</b>	
NA5035	291	<b>504</b>	
NA5035	291	<b>505</b>	
NA5045	440	<b>772</b>	
NA5045	468	<b>831</b>	
NA5045	478	<b>850</b>	
NA5045	507	<b>904</b>	
NA5049	426	<b>749</b>	
NA5049	432	<b>758</b>	
NA5049	433	<b>760</b>	
NA5049	433	<b>761</b>	
NA5049	434	<b>762</b>	
NA5049	439	<b>770</b>	
NA5049	479	<b>851</b>	
NA5049	488	<b>871</b>	
NA5049	490	<b>873</b>	
NA5049	491	<b>874</b>	
NA5049	512	<b>911</b>	
NA5049	514	<b>913</b>	
NA5049	694	<b>1184</b>	
NA5049	695	<b>1186</b>	
NA5049	697	<b>1188</b>	
NA5049	698	<b>1191</b>	

# NUMERICAL PARTS LIST

Nummerische Teilenummernliste • Elenco riferimenti  
Liste des références produits

			<b>9</b>
NA5049	700	<b>1193</b>	
NA5049	700	<b>1194</b>	
NA5049	701	<b>1196</b>	
NA5049	702	<b>1197</b>	
NA5049	703	<b>1199</b>	
NA5049	705	<b>1202</b>	
NA5049	705	<b>1203</b>	
NA5049	713	<b>1215</b>	
NA5050	480	<b>853</b>	
NA5050	499	<b>888</b>	
NA5050	503	<b>896</b>	
NA5050	607	<b>1058</b>	
NA5050	608	<b>1059</b>	
NA5050	614	<b>1067</b>	
NA5050	619	<b>1076</b>	
NA5050	640	<b>1110</b>	
NA5051	475	<b>845</b>	
NA5051	476	<b>846</b>	
NA5051	510	<b>909</b>	
NA5051	511	<b>910</b>	
NA5051	513	<b>912</b>	
NA5051	515	<b>915</b>	
NA5051	516	<b>916</b>	
NA5051	685	<b>1172</b>	
NA5051	703	<b>1199</b>	
NA5051	703	<b>1200</b>	
NA5051	705	<b>1202</b>	
NA5051	705	<b>1203</b>	
NA5051	707	<b>1205</b>	
NA5051	707	<b>1206</b>	
NA5051	708	<b>1207</b>	
NA5051	708	<b>1208</b>	
NA5051	710	<b>1211</b>	
NA5051	711	<b>1212</b>	
NA5051	713	<b>1215</b>	
NA5052	475	<b>845</b>	
NA5052	476	<b>846</b>	
NA5053	2	<b>2</b>	
NA5053	3	<b>3</b>	
NA5053	15	<b>34</b>	
NA5053	15	<b>35</b>	
NA5053	16	<b>36</b>	
NA5053	17	<b>37</b>	
NA5053	18	<b>38</b>	
NA5053	19	<b>39</b>	
NA5053	20	<b>40</b>	
NA5053	21	<b>41</b>	
NA5053	22	<b>43</b>	
NA5053	22	<b>44</b>	
NA5053	24	<b>47</b>	
NA5053	25	<b>48</b>	
NA5053	26	<b>49</b>	
NA5053	27	<b>50</b>	
NA5053	29	<b>53</b>	
NA5053	29	<b>54</b>	
NA5053	30	<b>55</b>	
NA5053	30	<b>56</b>	
NA5053	32	<b>58</b>	
NA5053	33	<b>59</b>	
NA5053	36	<b>62</b>	

			<b>9</b>
NA5053	37	<b>63</b>	
NA5053	38	<b>64</b>	
NA5053	52	<b>97</b>	
NA5053	66	<b>128</b>	
NA5053	90	<b>184</b>	
NA5053	91	<b>185</b>	
NA5053	91	<b>186</b>	
NA5053	92	<b>187</b>	
NA5053	93	<b>189</b>	
NA5053	94	<b>190</b>	
NA5053	95	<b>191</b>	
NA5053	95	<b>192</b>	
NA5053	96	<b>193</b>	
NA5053	97	<b>194</b>	
NA5053	98	<b>195</b>	
NA5053	99	<b>196</b>	
NA5053	100	<b>197</b>	
NA5053	101	<b>198</b>	
NA5053	102	<b>199</b>	
NA5053	103	<b>200</b>	
NA5053	104	<b>201</b>	
NA5053	104	<b>202</b>	
NA5053	105	<b>203</b>	
NA5053	106	<b>204</b>	
NA5053	107	<b>205</b>	
NA5053	108	<b>206</b>	
NA5053	109	<b>208</b>	
NA5053	110	<b>209</b>	
NA5053	111	<b>210</b>	
NA5053	112	<b>211</b>	
NA5053	113	<b>212</b>	
NA5053	114	<b>213</b>	
NA5053	115	<b>214</b>	
NA5053	115	<b>215</b>	
NA5053	116	<b>216</b>	
NA5053	117	<b>217</b>	
NA5053	118	<b>218</b>	
NA5053	119	<b>219</b>	
NA5053	120	<b>220</b>	
NA5053	121	<b>221</b>	
NA5053	122	<b>222</b>	
NA5053	123	<b>223</b>	
NA5053	124	<b>224</b>	
NA5053	124	<b>225</b>	
NA5053	125	<b>226</b>	
NA5053	125	<b>227</b>	
NA5053	126	<b>228</b>	
NA5053	126	<b>229</b>	
NA5053	127	<b>230</b>	
NA5053	128	<b>231</b>	
NA5053	128	<b>232</b>	
NA5053	129	<b>233</b>	
NA5053	130	<b>235</b>	
NA5053	131	<b>236</b>	
NA5053	132	<b>237</b>	
NA5053	132	<b>238</b>	
NA5053	133	<b>239</b>	
NA5053	133	<b>240</b>	
NA5053	134	<b>241</b>	
NA5053	134	<b>242</b>	

			<b>9</b>
NA5053	135	<b>243</b>	
NA5053	135	<b>244</b>	
NA5053	136	<b>245</b>	
NA5053	136	<b>246</b>	
NA5053	137	<b>247</b>	
NA5053	138	<b>248</b>	
NA5053	139	<b>249</b>	
NA5053	139	<b>250</b>	
NA5053	140	<b>251</b>	
NA5053	140	<b>252</b>	
NA5053	141	<b>253</b>	
NA5053	142	<b>254</b>	
NA5053	143	<b>255</b>	
NA5053	144	<b>256</b>	
NA5053	145	<b>257</b>	
NA5053	146	<b>258</b>	
NA5053	147	<b>259</b>	
NA5053	148	<b>260</b>	
NA5053	149	<b>261</b>	
NA5053	150	<b>262</b>	
NA5053	151	<b>263</b>	
NA5053	151	<b>264</b>	
NA5053	152	<b>265</b>	
NA5053	153	<b>266</b>	
NA5053	154	<b>267</b>	
NA5053	155	<b>268</b>	
NA5053	156	<b>269</b>	
NA5053	157	<b>270</b>	
NA5053	158	<b>271</b>	
NA5053	159	<b>272</b>	
NA5053	160	<b>273</b>	
NA5053	161	<b>274</b>	
NA5053	162	<b>275</b>	
NA5053	163	<b>276</b>	
NA5053	164	<b>277</b>	
NA5053	169	<b>289</b>	
NA5053	170	<b>290</b>	
NA5053	181	<b>309</b>	
NA5053	182	<b>310</b>	
NA5053	206	<b>343</b>	
NA5053	206	<b>344</b>	
NA5053	207	<b>345</b>	
NA5053	208	<b>346</b>	
NA5053	208	<b>347</b>	
NA5053	209	<b>348</b>	
NA5053	210	<b>349</b>	
NA5053	211	<b>350</b>	
NA5053	212	<b>351</b>	
NA5053	212	<b>352</b>	
NA5053	213	<b>354</b>	
NA5053	214	<b>355</b>	
NA5053	215	<b>356</b>	
NA5053	216	<b>357</b>	
NA5053	236	<b>400</b>	
NA5053	254	<b>439</b>	
NA5053	255	<b>442</b>	
NA5053	256	<b>443</b>	
NA5053	256	<b>444</b>	
NA5053	260	<b>451</b>	
NA5053	261	<b>452</b>	

			<b>9</b>
NA5053	268	<b>460</b>	
NA5053	268	<b>461</b>	
NA5053	271	<b>465</b>	
NA5053	272	<b>466</b>	
NA5053	272	<b>467</b>	
NA5053	273	<b>468</b>	
NA5053	276	<b>474</b>	
NA5053	277	<b>475</b>	
NA5053	278	<b>476</b>	
NA5053	278	<b>477</b>	
NA5053	279	<b>478</b>	
NA5053	281	<b>482</b>	
NA5055	757	<b>1268</b>	
NA5055	783	<b>1288</b>	
NA5055	785	<b>1289</b>	
NA5055	821	<b>1316</b>	
NA5057	441	<b>774</b>	
NA5057	449	<b>789</b>	
NA5057	450	<b>792</b>	
NA5057	452	<b>796</b>	
NA5057	453	<b>797</b>	
NA5057	455	<b>801</b>	
NA5057	455	<b>802</b>	
NA5057	456	<b>803</b>	
NA5057	456	<b>804</b>	
NA5057	457	<b>806</b>	
NA5057	458	<b>807</b>	
NA5057	458	<b>808</b>	
NA5057	459	<b>809</b>	
NA5057	460	<b>810</b>	
NA5057	460	<b>811</b>	
NA5057	461	<b>812</b>	
NA5057	461	<b>813</b>	
NA5057	462	<b>814</b>	
NA5057	462	<b>815</b>	
NA5057	463	<b>816</b>	
NA5057	463	<b>817</b>	
NA5057	464	<b>818</b>	
NA5057	464	<b>819</b>	
NA5057	465	<b>820</b>	
NA5057	465	<b>821</b>	
NA5057	465	<b>822</b>	
NA5057	466	<b>824</b>	
NA5057	466	<b>825</b>	
NA5057	467	<b>827</b>	
NA5057	467	<b>829</b>	
NA5058	11	<b>23</b>	
NA5058	23	<b>45</b>	
NA5058	23	<b>46</b>	
NA5058	28	<b>51</b>	
NA5058	28	<b>52</b>	
NA5058	31	<b>57</b>	
NA5058	34	<b>60</b>	
NA5058	35	<b>61</b>	
NA5058	38	<b>65</b>	
NA5058	39	<b>66</b>	
NA5058	39	<b>67</b>	
NA5058	40	<b>68</b>	
NA5058	40	<b>69</b>	
NA5058	41	<b>70</b>	



			9
NA5058	41	<b>72</b>	
NA5058	42	<b>73</b>	
NA5058	42	<b>74</b>	
NA5058	42	<b>75</b>	
NA5058	43	<b>76</b>	
NA5058	44	<b>77</b>	
NA5058	198	<b>329</b>	
NA5061	441	<b>774</b>	
NA5061	448	<b>787</b>	
NA5061	449	<b>789</b>	
NA5061	452	<b>796</b>	
NA5061	453	<b>797</b>	
NA5061	453	<b>798</b>	
NA5061	454	<b>799</b>	
NA5061	454	<b>800</b>	
NA5061	455	<b>801</b>	
NA5061	455	<b>802</b>	
NA5061	456	<b>803</b>	
NA5061	456	<b>804</b>	
NA5061	457	<b>805</b>	
NA5061	458	<b>807</b>	
NA5061	458	<b>808</b>	
NA5061	459	<b>809</b>	
NA5061	464	<b>819</b>	
NA5061	466	<b>824</b>	
NA5061	466	<b>825</b>	
NA5061	492	<b>876</b>	
NA5063	493	<b>878</b>	
NA5063	494	<b>880</b>	
NA5063	495	<b>882</b>	
NA5063	497	<b>885</b>	
NA5063	601	<b>1048</b>	
NA5063	601	<b>1049</b>	
NA5063	604	<b>1053</b>	
NA5063	604	<b>1054</b>	
NA5063	713	<b>1216</b>	
NA5063	714	<b>1217</b>	
NA5063	716	<b>1220</b>	
NA5063	717	<b>1221</b>	
NA5064	67	<b>130</b>	
NA5064	67	<b>131</b>	
NA5064	68	<b>132</b>	
NA5064	68	<b>133</b>	
NA5064	68	<b>135</b>	
NA5064	69	<b>136</b>	
NA5064	69	<b>137</b>	
NA5064	70	<b>138</b>	
NA5064	71	<b>140</b>	
NA5064	71	<b>141</b>	
NA5064	217	<b>360</b>	
NA5064	218	<b>361</b>	
NA5064	219	<b>363</b>	
NA5064	219	<b>364</b>	
NA5064	220	<b>365</b>	
NA5064	221	<b>367</b>	
NA5064	222	<b>369</b>	
NA5064	222	<b>370</b>	
NA5064	232	<b>393</b>	
NA5064	325	<b>563</b>	
NA5064	326	<b>564</b>	

			9
NA5064	326	<b>565</b>	
NA5064	327	<b>567</b>	
NA5065	493	<b>878</b>	
NA5065	494	<b>880</b>	
NA5065	495	<b>882</b>	
NA5065	497	<b>885</b>	
NA5065	599	<b>1042</b>	
NA5065	601	<b>1048</b>	
NA5065	601	<b>1049</b>	
NA5065	604	<b>1053</b>	
NA5065	604	<b>1054</b>	
NA5065	673	<b>1151</b>	
NA5065	714	<b>1217</b>	
NA5065	716	<b>1220</b>	
NA5065	717	<b>1221</b>	
NA5066	469	<b>833</b>	
NA5066	470	<b>835</b>	
NA5066	470	<b>836</b>	
NA5066	480	<b>854</b>	
NA5066	482	<b>856</b>	
NA5066	482	<b>857</b>	
NA5066	483	<b>859</b>	
NA5066	484	<b>860</b>	
NA5066	484	<b>861</b>	
NA5066	498	<b>886</b>	
NA5066	505	<b>898</b>	
NA5066	505	<b>899</b>	
NA5066	506	<b>900</b>	
NA5066	599	<b>1042</b>	
NA5066	631	<b>1097</b>	
NA5066	632	<b>1098</b>	
NA5066	633	<b>1100</b>	
NA5066	634	<b>1101</b>	
NA5066	635	<b>1102</b>	
NA5066	635	<b>1103</b>	
NA5066	636	<b>1104</b>	
NA5066	636	<b>1105</b>	
NA5066	637	<b>1106</b>	
NA5066	639	<b>1108</b>	
NA5066	671	<b>1149</b>	
NA5066	673	<b>1151</b>	
NA5069	93	<b>189</b>	
NA5069	94	<b>190</b>	
NA5069	95	<b>191</b>	
NA5069	95	<b>192</b>	
NA5069	96	<b>193</b>	
NA5069	97	<b>194</b>	
NA5069	98	<b>195</b>	
NA5069	99	<b>196</b>	
NA5069	100	<b>197</b>	
NA5069	101	<b>198</b>	
NA5069	102	<b>199</b>	
NA5069	103	<b>200</b>	
NA5069	105	<b>203</b>	
NA5069	106	<b>204</b>	
NA5069	107	<b>205</b>	
NA5069	108	<b>206</b>	
NA5069	146	<b>258</b>	
NA5069	147	<b>259</b>	
NA5069	148	<b>260</b>	

			9
NA5069	149	<b>261</b>	
NA5069	150	<b>262</b>	
NA5069	151	<b>263</b>	
NA5069	151	<b>264</b>	
NA5069	152	<b>265</b>	
NA5069	153	<b>266</b>	
NA5069	154	<b>267</b>	
NA5069	212	<b>352</b>	
NA5069	213	<b>354</b>	
NA5070	485	<b>864</b>	
NA5070	486	<b>865</b>	
NA5070	486	<b>866</b>	
NA5070	486	<b>867</b>	
NA5070	487	<b>869</b>	
NA5070	518	<b>922</b>	
NA5070	518	<b>923</b>	
NA5070	519	<b>924</b>	
NA5070	520	<b>926</b>	
NA5070	521	<b>927</b>	
NA5070	522	<b>928</b>	
NA5070	523	<b>929</b>	
NA5070	523	<b>930</b>	
NA5070	524	<b>931</b>	
NA5070	525	<b>932</b>	
NA5070	525	<b>933</b>	
NA5070	527	<b>936</b>	
NA5070	527	<b>937</b>	
NA5070	528	<b>938</b>	
NA5070	529	<b>939</b>	
NA5070	530	<b>941</b>	
NA5070	531	<b>942</b>	
NA5070	531	<b>943</b>	
NA5070	532	<b>944</b>	
NA5070	533	<b>945</b>	
NA5070	534	<b>946</b>	
NA5070	534	<b>947</b>	
NA5070	535	<b>948</b>	
NA5070	535	<b>949</b>	
NA5070	536	<b>950</b>	
NA5070	536	<b>951</b>	
NA5070	537	<b>952</b>	
NA5070	538	<b>953</b>	
NA5070	538	<b>954</b>	
NA5070	539	<b>955</b>	
NA5070	540	<b>956</b>	
NA5070	541	<b>957</b>	
NA5070	541	<b>958</b>	
NA5070	541	<b>959</b>	
NA5070	542	<b>960</b>	
NA5070	542	<b>961</b>	
NA5070	543	<b>962</b>	
NA5070	543	<b>963</b>	
NA5070	543	<b>964</b>	
NA5070	544	<b>965</b>	
NA5070	545	<b>966</b>	
NA5070	545	<b>967</b>	
NA5070	546	<b>968</b>	
NA5070	547	<b>969</b>	
NA5070	547	<b>970</b>	
NA5070	547	<b>971</b>	

			9
NA5070	548	<b>972</b>	
NA5070	549	<b>973</b>	
NA5070	550	<b>974</b>	
NA5070	550	<b>975</b>	
NA5070	551	<b>976</b>	
NA5070	552	<b>977</b>	
NA5070	553	<b>978</b>	
NA5070	554	<b>979</b>	
NA5070	554	<b>980</b>	
NA5070	555	<b>981</b>	
NA5070	555	<b>982</b>	
NA5070	556	<b>983</b>	
NA5070	556	<b>984</b>	
NA5070	557	<b>985</b>	
NA5070	557	<b>986</b>	
NA5070	558	<b>987</b>	
NA5070	558	<b>988</b>	
NA5070	559	<b>989</b>	
NA5070	559	<b>990</b>	
NA5070	584	<b>1019</b>	
NA5070	585	<b>1020</b>	
NA5070	592	<b>1030</b>	
NA5070	593	<b>1032</b>	
NA5070	594	<b>1034</b>	
NA5070	595	<b>1035</b>	
NA5070	595	<b>1036</b>	
NA5070	596	<b>1037</b>	
NA5070	596	<b>1038</b>	
NA5070	597	<b>1039</b>	
NA5070	598	<b>1040</b>	
NA5070	599	<b>1043</b>	
NA5070	599	<b>1044</b>	
NA5070	600	<b>1045</b>	
NA5104	507	<b>902</b>	
NA5108	686	<b>1174</b>	
NA5163	77	<b>159</b>	
NA5163	78	<b>161</b>	
NA5163	79	<b>162</b>	
NA5163	79	<b>163</b>	
NA5163	164	<b>277</b>	
NA5163	164	<b>278</b>	
NA5163	165	<b>279</b>	
NA5163	165	<b>281</b>	
NA5163	166	<b>282</b>	
NA5163	166	<b>283</b>	
NA5163	169	<b>289</b>	
NA5163	210	<b>349</b>	
NA5163	213	<b>353</b>	
NA5163	280	<b>481</b>	
NA5163	337	<b>593</b>	
NA5163	337	<b>594</b>	
NA5163	338	<b>595</b>	
NA5163	338	<b>597</b>	
NA5163	339	<b>598</b>	
NA5163	339	<b>599</b>	
NA5163	340	<b>600</b>	
NA5163	340	<b>601</b>	
NA5163	340	<b>602</b>	
NA5163	395	<b>685</b>	
NA5163	395	<b>687</b>	

# NUMERICAL PARTS LIST

Nummerische Teilenummernliste • Elenco riferimenti  
Liste des références produits

 <span style="border: 1px solid black; padding: 2px;">9</span>		
NA5163	396	<b>688</b>
NA5163	396	<b>689</b>
NA5163	397	<b>690</b>
NA5163	397	<b>691</b>
NA5163	398	<b>692</b>
NA5163	398	<b>693</b>
NA5163	399	<b>694</b>
NA5163	400	<b>696</b>
NA5163	401	<b>698</b>
NA5163	401	<b>700</b>
NA5163	402	<b>701</b>
NA5163	403	<b>703</b>
NA5163	403	<b>704</b>
NA5163	725	<b>1237</b>
NA5163	726	<b>1239</b>
NA5163	830	<b>1325</b>
NA5174	516	<b>917</b>
NA5174	517	<b>918</b>
NA5177	430	<b>755</b>
NA5177	430	<b>756</b>
NA5177	435	<b>763</b>
NA5177	718	<b>1223</b>
NA5187	51	<b>95</b>
NA5187	52	<b>96</b>
NA5187	55	<b>104</b>
NA5187	55	<b>105</b>
NA5187	56	<b>106</b>
NA5187	60	<b>118</b>
NA5187	61	<b>119</b>
NA5187	62	<b>121</b>
NA5187	62	<b>122</b>
NA5187	63	<b>123</b>
NA5187	64	<b>124</b>
NA5187	65	<b>125</b>
NA5187	65	<b>126</b>
NA5187	66	<b>127</b>
NA5187	73	<b>149</b>
NA5187	81	<b>166</b>
NA5187	81	<b>167</b>
NA5187	82	<b>168</b>
NA5187	82	<b>169</b>
NA5187	83	<b>171</b>
NA5187	84	<b>172</b>
NA5187	85	<b>173</b>
NA5187	85	<b>174</b>
NA5187	86	<b>175</b>
NA5187	86	<b>176</b>
NA5187	87	<b>177</b>
NA5187	88	<b>180</b>
NA5187	89	<b>181</b>
NA5187	173	<b>296</b>
NA5187	173	<b>297</b>
NA5187	174	<b>299</b>
NA5187	175	<b>300</b>
NA5187	176	<b>301</b>
NA5187	177	<b>302</b>
NA5187	178	<b>303</b>
NA5187	179	<b>304</b>
NA5187	180	<b>306</b>
NA5187	181	<b>307</b>

 <span style="border: 1px solid black; padding: 2px;">9</span>		
NA5187	181	<b>308</b>
NA5187	183	<b>311</b>
NA5187	184	<b>312</b>
NA5187	185	<b>313</b>
NA5187	186	<b>314</b>
NA5187	187	<b>315</b>
NA5187	188	<b>316</b>
NA5187	189	<b>318</b>
NA5187	190	<b>319</b>
NA5187	191	<b>320</b>
NA5187	192	<b>321</b>
NA5187	193	<b>322</b>
NA5187	194	<b>323</b>
NA5187	195	<b>324</b>
NA5187	196	<b>325</b>
NA5187	197	<b>326</b>
NA5187	198	<b>328</b>
NA5187	223	<b>372</b>
NA5187	223	<b>373</b>
NA5187	224	<b>374</b>
NA5187	225	<b>376</b>
NA5187	225	<b>377</b>
NA5187	226	<b>378</b>
NA5187	228	<b>384</b>
NA5187	232	<b>394</b>
NA5187	234	<b>398</b>
NA5187	235	<b>399</b>
NA5187	238	<b>403</b>
NA5187	241	<b>409</b>
NA5187	242	<b>410</b>
NA5187	247	<b>427</b>
NA5187	250	<b>434</b>
NA5187	252	<b>437</b>
NA5187	253	<b>438</b>
NA5187	254	<b>440</b>
NA5187	255	<b>441</b>
NA5187	266	<b>457</b>
NA5187	270	<b>464</b>
NA5187	273	<b>469</b>
NA5187	275	<b>472</b>
NA5187	280	<b>480</b>
NA5187	292	<b>506</b>
NA5187	298	<b>519</b>
NA5187	298	<b>520</b>
NA5187	299	<b>521</b>
NA5187	300	<b>522</b>
NA5187	302	<b>526</b>
NA5187	303	<b>527</b>
NA5187	303	<b>528</b>
NA5187	304	<b>529</b>
NA5187	305	<b>530</b>
NA5187	306	<b>532</b>
NA5187	307	<b>533</b>
NA5187	310	<b>538</b>
NA5187	311	<b>539</b>
NA5187	311	<b>540</b>
NA5187	312	<b>541</b>
NA5187	312	<b>542</b>
NA5187	313	<b>543</b>
NA5187	314	<b>545</b>

 <span style="border: 1px solid black; padding: 2px;">9</span>		
NA5187	314	<b>546</b>
NA5187	315	<b>547</b>
NA5187	315	<b>548</b>
NA5187	316	<b>549</b>
NA5187	317	<b>551</b>
NA5187	317	<b>552</b>
NA5187	318	<b>553</b>
NA5187	318	<b>554</b>
NA5187	319	<b>555</b>
NA5187	319	<b>556</b>
NA5187	320	<b>557</b>
NA5187	321	<b>558</b>
NA5187	325	<b>562</b>
NA5191	560	<b>991</b>
NA5191	561	<b>992</b>
NA5191	585	<b>1021</b>
NA5191	585	<b>1022</b>
NA5191	587	<b>1024</b>
NA5191	588	<b>1025</b>
NA5191	589	<b>1026</b>
NA5191	590	<b>1027</b>
NA5191	590	<b>1028</b>
NA5191	591	<b>1029</b>
NA5191	629	<b>1094</b>
NA5191	674	<b>1153</b>
NA5191	674	<b>1154</b>
NA5191	675	<b>1155</b>
NA5191	676	<b>1158</b>
NA5191	677	<b>1160</b>
NA5191	678	<b>1161</b>
NA5191	678	<b>1162</b>
NA5191	679	<b>1163</b>
NA5191	680	<b>1164</b>
NA5191	680	<b>1165</b>
NA5191	681	<b>1166</b>
NA5191	682	<b>1167</b>
NA5191	683	<b>1168</b>
NA5191	683	<b>1169</b>
NA5191	684	<b>1170</b>
NA5191	687	<b>1175</b>
NA5191	687	<b>1176</b>
NA5191	689	<b>1178</b>
NA5191	690	<b>1179</b>
NA5191	718	<b>1224</b>
NA5191	719	<b>1225</b>
NA5192	560	<b>991</b>
NA5192	561	<b>992</b>
NA5192	585	<b>1021</b>
NA5192	585	<b>1022</b>
NA5192	587	<b>1024</b>
NA5192	588	<b>1025</b>
NA5192	589	<b>1026</b>
NA5192	590	<b>1027</b>
NA5192	590	<b>1028</b>
NA5192	591	<b>1029</b>
NA5192	674	<b>1153</b>
NA5192	674	<b>1154</b>
NA5192	675	<b>1155</b>
NA5192	676	<b>1158</b>
NA5192	677	<b>1160</b>

 <span style="border: 1px solid black; padding: 2px;">9</span>		
NA5192	678	<b>1161</b>
NA5192	678	<b>1162</b>
NA5192	679	<b>1163</b>
NA5192	680	<b>1165</b>
NA5192	682	<b>1167</b>
NA5192	683	<b>1168</b>
NA5192	683	<b>1169</b>
NA5192	687	<b>1175</b>
NA5192	687	<b>1176</b>
NA5192	690	<b>1179</b>
NA5192	719	<b>1225</b>
NA5201	332	<b>580</b>
NA5201	333	<b>582</b>
NA5201	334	<b>583</b>
NA5201	334	<b>585</b>
NA5201	335	<b>586</b>
NA5201	336	<b>588</b>
NA5201	336	<b>589</b>
NA5201	337	<b>591</b>
NA5202	721	<b>1229</b>
NA5202	723	<b>1232</b>
NA5202	724	<b>1233</b>
NA5202	724	<b>1235</b>
NA5202	725	<b>1236</b>
NA5223	441	<b>773</b>
NA5223	442	<b>775</b>
NA5223	442	<b>776</b>
NA5223	443	<b>777</b>
NA5223	443	<b>778</b>
NA5223	444	<b>779</b>
NA5223	444	<b>780</b>
NA5223	445	<b>781</b>
NA5223	446	<b>782</b>
NA5223	446	<b>783</b>
NA5223	446	<b>784</b>
NA5230	441	<b>773</b>
NA5230	442	<b>775</b>
NA5230	442	<b>776</b>
NA5230	443	<b>777</b>
NA5230	443	<b>778</b>
NA5230	444	<b>779</b>
NA5230	444	<b>780</b>
NA5230	445	<b>781</b>
NA5230	446	<b>782</b>
NA5230	446	<b>783</b>
NA5230	446	<b>784</b>
NA5256	676	<b>1156</b>
NA5256	676	<b>1157</b>
NA5258	47	<b>86</b>
NA5258	399	<b>695</b>
NA5260	329	<b>570</b>
NA5260	329	<b>571</b>
NA5260	329	<b>572</b>
NA5260	717	<b>1222</b>
NA5305	770	<b>1278</b>
NA5321	44	<b>78</b>
NA5321	45	<b>79</b>
NA5321	45	<b>81</b>
NA5321	45	<b>82</b>
NA5325	471	<b>838</b>

			<b>9</b>
NB698	484	862	
NB698	517	919	
NB728	479	851	
NB732	561	993	
NB732	563	994	
NB732	564	995	
NB732	564	996	
NB732	565	997	
NB732	566	998	
NB732	568	1000	
NB732	569	1001	
NB732	570	1002	
NB732	571	1003	
NB732	572	1004	
NB732	573	1005	
NB732	573	1006	
NB732	574	1007	
NB732	575	1008	
NB732	576	1009	
NB732	578	1010	
NB732	579	1011	
NB732	580	1012	
NB732	581	1013	
NB732	582	1014	
NB732	584	1018	
NB732	616	1069	
NB732	622	1081	
NB732	624	1085	
NB732	626	1087	
NB732	626	1089	
NB732	627	1090	
NB732	639	1109	
NB732	643	1114	
NB732	644	1115	
NB732	645	1116	
NB732	646	1117	
NB732	648	1121	
NB732	650	1124	
NB732	651	1125	
NB732	652	1127	
NB732	653	1128	
NB732	654	1129	
NB732	655	1130	
NB732	656	1131	
NB732	657	1132	
NB732	658	1133	
NB732	659	1134	
NB732	661	1136	
NB732	662	1137	
NB732	663	1138	
NB732	665	1140	
NB732	666	1141	
NB732	667	1142	
NB732	669	1144	
NB732	669	1145	
NB732	670	1147	
NB732	672	1150	
NB732	673	1152	
NB742	480	853	
NB742	561	993	

			<b>9</b>
NB742	563	994	
NB742	564	995	
NB742	564	996	
NB742	565	997	
NB742	566	998	
NB742	568	1000	
NB742	569	1001	
NB742	570	1002	
NB742	571	1003	
NB742	572	1004	
NB742	573	1005	
NB742	573	1006	
NB742	574	1007	
NB742	575	1008	
NB742	576	1009	
NB742	578	1010	
NB742	579	1011	
NB742	580	1012	
NB742	581	1013	
NB742	582	1014	
NB742	614	1067	
NB742	622	1080	
NB742	622	1081	
NB742	624	1085	
NB742	626	1089	
NB742	627	1090	
NB742	643	1114	
NB742	644	1115	
NB742	645	1116	
NB742	646	1117	
NB742	647	1119	
NB742	648	1121	
NB742	650	1123	
NB742	650	1124	
NB742	653	1128	
NB742	654	1129	
NB742	655	1130	
NB742	658	1133	
NB742	661	1136	
NB742	662	1137	
NB742	665	1140	
NB742	666	1141	
NB742	667	1142	
NB742	669	1144	
NB742	670	1147	
NB742	672	1150	
NB806	686	1174	
NB808	430	755	
NB808	430	756	
NB808	432	758	
NB808	433	760	
NB808	433	761	
NB808	434	762	
NB808	435	763	
NB808	436	765	
NB808	437	766	
NB808	471	839	
NB808	510	909	
NB808	511	910	
NB808	513	912	

			<b>9</b>
NB808	515	915	
NB808	713	1215	
NB814	427	750	
NB814	447	785	
NB814	447	786	
NB814	448	787	
NB814	449	790	
NB814	451	793	
NB814	452	795	
NB814	477	847	
NB815	427	750	
NB815	447	785	
NB815	447	786	
NB815	448	787	
NB815	449	788	
NB815	449	789	
NB815	449	790	
NB815	451	793	
NB815	452	795	
NB815	453	798	
NB815	454	799	
NB815	454	800	
NB815	456	803	
NB815	456	804	
NB815	457	805	
NB815	458	808	
NB815	459	809	
NB815	466	826	
NB815	477	847	
NB815	492	876	
NB818	488	871	
NB818	490	873	
NB818	491	874	
NB818	491	875	
NB818	499	888	
NB818	503	896	
NB818	509	907	
NB818	510	909	
NB818	511	910	
NB818	512	911	
NB818	513	912	
NB818	514	913	
NB818	514	914	
NB818	515	915	
NB818	516	916	
NB818	584	1018	
NB818	607	1058	
NB818	608	1059	
NB818	619	1076	
NB818	639	1109	
NB818	694	1184	
NB818	695	1185	
NB818	695	1186	
NB818	697	1188	
NB818	698	1191	
NB818	700	1193	
NB818	700	1194	
NB818	701	1196	
NB818	702	1197	
NB818	703	1200	

			<b>9</b>
NB818	706	1204	
NB818	707	1205	
NB818	707	1206	
NB818	708	1207	
NB818	708	1208	
NB818	709	1209	
NB818	710	1210	
NB818	710	1211	
NB818	711	1212	
NB818	713	1215	
NB825	624	1085	
NB825	626	1087	
NB825	626	1089	
NB825	650	1123	
NB825	651	1125	
NB825	656	1131	
NB825	657	1132	
NB825	659	1134	
NB825	663	1138	
NB825	669	1145	
NB825	673	1152	
NB866	47	87	
NB946	731	1250	
NB946	735	1253	
NB946	742	1259	
NB946	743	1260	
NB946	751	1264	
NB946	753	1265	
NB946	764	1272	
NB946	814	1311	
NB946	817	1313	
NB946	819	1314	
NB946	822	1318	
NB946	827	1321	
NC006	59	114	
NC006	89	182	
NC006	90	183	
NF722	600	1046	
NF722	600	1047	
NF722	628	1092	
NF722	629	1093	
NF817	46	85	
NF817	199	330	
NF817	281	484	
NF817	282	485	
NF817	282	486	
NF817	283	487	
NF817	293	509	
NF817	294	510	
NF817	294	511	
NF817	295	512	
NF817	295	513	
NF817	296	514	
NF817	296	515	
NF833	731	1250	
NF833	741	1258	
NF833	743	1260	
NF833	745	1261	
NF833	747	1262	
NF833	749	1263	

# NUMERICAL PARTS LIST

Nummerische Teilenummernliste • Elenco riferimenti  
Liste des références produits

 <span style="border: 1px solid black; padding: 2px;">9</span>		
NF833	753	1265
NF833	755	1266
NF833	760	1270
NF833	778	1283
NF833	779	1284
NF833	804	1305
NF841	171	292
NF841	171	293
NF841	172	294
NF841	200	331
NF841	200	332
NF841	201	333
NF841	202	334
NF841	202	335
NF841	203	336
NF841	203	337
NF841	204	338
NF841	204	339
NF841	288	499
NF841	289	500
NF841	361	633
NF841	382	667
NF841	383	669
NF841	392	681
NF853	733	1252
NF853	738	1255
NF853	762	1271
NF853	764	1272
NF853	785	1289
NF853	790	1292
NF853	790	1293
NF853	803	1303
NF853	807	1307
NF853	809	1308
NF853	814	1311
NF853	817	1313
NF853	819	1314
NF853	822	1318
NF853	824	1319
NF853	827	1321
NF853	833	1331
NF857	471	837
NF867	717	1222
NF867	718	1223
NF870	471	837
NF883	733	1252
NF883	766	1275
NF883	767	1276
NF883	783	1288
NF883	788	1291
NF883	797	1297
NF883	798	1298
NF883	799	1299
NF883	798	1298
NF883	799	1299
NF883	801	1301
NF883	802	1302
NF883	821	1316
NF883	832	1329
NF883	833	1330
NF883	833	1331
NF883	835	1333
NF883	837	1335
NF883	838	1336
NF883	839	1337
NF883	840	1339
NF883	841	1340
NF883	841	1341
NF883	842	1342
NF883	843	1343
NF883	844	1344
NF883	845	1345
NF883	733	1252
NF883	766	1275
NF883	767	1276
NF883	779	1284
NF883	783	1288
NF883	788	1291
NF883	797	1297
NF883	798	1298
NF883	799	1299
NF883	801	1301
NF883	802	1302
NF883	821	1316
NF883	832	1329
NF883	833	1330
NF883	833	1331
NF883	835	1333
NF883	837	1335
NF883	838	1336
NF883	839	1337
NF883	840	1339
NF883	841	1340
NF883	841	1341
NF883	842	1342
NF883	843	1343
NF883	844	1344
NF883	845	1345
NF886	733	1252
NF886	766	1275
NF886	767	1276
NF886	779	1284
NF886	783	1288
NF886	788	1291
NF886	797	1297
NF886	833	1331
NF887	514	914
NF887	516	916
NF887	704	1201
NF887	706	1204
NF887	707	1205
NF887	707	1206
NF887	708	1208
NF887	709	1209
NF887	710	1210
NF887	710	1211
NF887	711	1212
NF887	711	1213
NF888	485	864
NF888	486	865
NF888	486	866
NF888	486	867

 <span style="border: 1px solid black; padding: 2px;">9</span>		
NF888	487	869
NF888	518	923
NF888	519	924
NF888	520	926
NF888	521	927
NF888	522	928
NF888	523	929
NF888	523	930
NF888	524	931
NF888	525	932
NF888	525	933
NF888	527	936
NF888	527	937
NF888	528	938
NF888	529	939
NF888	530	941
NF888	531	942
NF888	531	943
NF888	532	944
NF888	533	945
NF888	534	946
NF888	534	947
NF888	535	948
NF888	535	949
NF888	536	950
NF888	536	951
NF888	537	952
NF888	538	953
NF888	538	954
NF888	539	955
NF888	540	956
NF888	541	957
NF888	541	958
NF888	541	959
NF888	542	960
NF888	542	961
NF888	543	962
NF888	543	963
NF888	543	964
NF888	544	965
NF888	545	966
NF888	545	967
NF888	546	968
NF888	547	969
NF888	547	970
NF888	547	971
NF888	548	972
NF888	549	973
NF888	550	974
NF888	550	975
NF888	551	976
NF888	552	977
NF888	553	978
NF888	554	979
NF888	554	980
NF888	555	981
NF888	555	982
NF888	556	983
NF888	556	984
NF888	557	985

 <span style="border: 1px solid black; padding: 2px;">9</span>		
NF888	557	986
NF888	558	987
NF888	558	988
NF888	559	989
NF888	559	990
NF888	584	1019
NF888	585	1020
NF888	592	1030
NF888	593	1032
NF888	594	1034
NF888	595	1035
NF888	595	1036
NF888	596	1037
NF888	596	1038
NF888	597	1039
NF888	598	1040
NF888	599	1043
NF888	599	1044
NF888	600	1045
NJ951	78	160
NJ951	340	601
NJ951	340	602
NJ951	341	603
NJ951	397	691
NJ951	402	701
NJ951	728	1243
NJ951	831	1327
NP067	347	614
NP067	348	616
NP067	351	619
NP067	352	620
NP067	357	626
NP067	363	635
NP067	363	636
NP067	370	647
NP067	372	650
NP067	373	652
NP067	376	658
NP067	389	677
NP067	406	711
NP067	413	724
NP067	668	1143
NP067	733	1252
NP067	738	1255
NP067	747	1262
NP067	749	1263
NP067	755	1266
NP067	760	1270
NP067	766	1275
NP067	767	1276
NP067	770	1278
NP067	773	1280
NP067	779	1284
NP067	780	1285
NP067	781	1286
NP067	782	1287
NP067	783	1288
NP067	785	1289
NP067	788	1291
NP067	792	1294

 <span style="border: 1px solid black; padding: 2px;">9</span>		
NF888	487	869
NF888	518	923
NF888	519	924
NF888	520	926
NF888	521	927
NF888	522	928
NF888	523	929
NF888	523	930
NF888	524	931
NF888	525	932
NF888	525	933
NF888	527	936
NF888	527	937
NF888	528	938
NF888	529	939
NF888	530	941
NF888	531	942
NF888	531	943
NF888	532	944
NF888	533	945
NF888	534	946
NF888	534	947
NF888	535	948
NF888	535	949
NF888	536	950
NF888	536	951
NF888	537	952
NF888	538	953
NF888	538	954
NF888	539	955
NF888	540	956
NF888	541	957
NF888	541	958
NF888	541	959
NF888	542	960
NF888	542	961
NF888	543	962
NF888	543	963
NF888	543	964
NF888	544	965
NF888	545	966
NF888	545	967
NF888	546	968
NF888	547	969
NF888	547	970
NF888	547	971
NF888	548	972
NF888	549	973
NF888	550	974
NF888	550	975
NF888	551	976
NF888	552	977
NF888	553	978
NF888	554	979
NF888	554	980
NF888	555	981
NF888	555	982
NF888	556	983
NF888	556	984
NF888	557	985

		9
NP067	794	<b>1295</b>
NP067	797	<b>1297</b>
NP067	798	<b>1298</b>
NP067	799	<b>1299</b>
NP067	801	<b>1301</b>
NP067	802	<b>1302</b>
NP067	811	<b>1309</b>
NP067	812	<b>1310</b>
NP067	822	<b>1317</b>
NP067	832	<b>1329</b>
NP067	833	<b>1331</b>
NP067	835	<b>1333</b>
NP067	838	<b>1336</b>
NP067	839	<b>1337</b>
NP067	840	<b>1339</b>
NP067	841	<b>1341</b>
NP067	843	<b>1343</b>
NP068	274	<b>470</b>
NP068	345	<b>612</b>
NP068	347	<b>614</b>
NP068	348	<b>615</b>
NP068	348	<b>616</b>
NP068	349	<b>617</b>
NP068	350	<b>618</b>
NP068	351	<b>619</b>
NP068	353	<b>621</b>
NP068	354	<b>622</b>
NP068	354	<b>623</b>
NP068	355	<b>624</b>
NP068	356	<b>625</b>
NP068	357	<b>626</b>
NP068	358	<b>628</b>
NP068	359	<b>630</b>
NP068	359	<b>631</b>
NP068	361	<b>633</b>
NP068	362	<b>634</b>
NP068	363	<b>635</b>
NP068	363	<b>636</b>
NP068	364	<b>637</b>
NP068	364	<b>638</b>
NP068	367	<b>641</b>
NP068	369	<b>645</b>
NP068	370	<b>646</b>
NP068	371	<b>648</b>
NP068	371	<b>649</b>
NP068	372	<b>650</b>
NP068	372	<b>651</b>
NP068	373	<b>652</b>
NP068	374	<b>653</b>
NP068	375	<b>655</b>
NP068	376	<b>657</b>
NP068	376	<b>658</b>
NP068	378	<b>660</b>
NP068	380	<b>663</b>
NP068	381	<b>665</b>
NP068	381	<b>666</b>
NP068	382	<b>667</b>
NP068	383	<b>668</b>
NP068	384	<b>670</b>
NP068	385	<b>672</b>

		9
NP068	386	<b>674</b>
NP068	387	<b>675</b>
NP068	388	<b>676</b>
NP068	389	<b>677</b>
NP068	390	<b>679</b>
NP068	391	<b>680</b>
NP068	392	<b>681</b>
NP068	393	<b>682</b>
NP068	394	<b>683</b>
NP068	394	<b>684</b>
NP068	405	<b>710</b>
NP068	406	<b>711</b>
NP068	407	<b>712</b>
NP068	408	<b>713</b>
NP068	408	<b>714</b>
NP068	410	<b>717</b>
NP068	410	<b>718</b>
NP068	411	<b>719</b>
NP068	412	<b>721</b>
NP068	412	<b>722</b>
NP068	413	<b>723</b>
NP068	414	<b>725</b>
NP068	414	<b>726</b>
NP068	415	<b>727</b>
NP068	415	<b>729</b>
NP068	416	<b>730</b>
NP068	416	<b>731</b>
NP068	417	<b>732</b>
NP068	418	<b>734</b>
NP068	419	<b>736</b>
NP068	420	<b>737</b>
NP068	762	<b>1271</b>
NP068	824	<b>1319</b>
NP068	826	<b>1320</b>
PA349	587	<b>1024</b>
PA349	588	<b>1025</b>
PA349	682	<b>1167</b>
PA349	687	<b>1176</b>
PA349	719	<b>1225</b>
PA5025	42	<b>74</b>
PA5025	43	<b>76</b>
PB907	560	<b>991</b>
PB907	561	<b>992</b>
PB907	585	<b>1021</b>
PB907	589	<b>1026</b>
PB907	590	<b>1027</b>
PB907	680	<b>1165</b>
PB907	682	<b>1167</b>
PB907	687	<b>1176</b>
TB106	68	<b>132</b>
TB106	69	<b>136</b>
TB106	69	<b>137</b>
TB106	70	<b>138</b>
TB106	217	<b>360</b>
TB106	218	<b>361</b>
TB106	219	<b>363</b>
TB106	219	<b>364</b>
TB106	220	<b>365</b>
TB106	220	<b>366</b>
TB106	221	<b>367</b>

		9
TB106	221	<b>368</b>
TB106	222	<b>369</b>
TB106	222	<b>370</b>
TB106	325	<b>563</b>
TB112	226	<b>378</b>
TB112	226	<b>379</b>
TB112	227	<b>380</b>
TB112	227	<b>381</b>
TB112	228	<b>383</b>
TB112	229	<b>386</b>
TB112	230	<b>387</b>
TB114	48	<b>90</b>
TB114	62	<b>121</b>
TB114	62	<b>122</b>
TB114	63	<b>123</b>
TB114	64	<b>124</b>
TB114	65	<b>125</b>
TB114	67	<b>129</b>
TB114	298	<b>519</b>
TB114	300	<b>522</b>
TB114	301	<b>523</b>
TB114	301	<b>524</b>
TB114	302	<b>526</b>
TB121	47	<b>88</b>
TB121	48	<b>89</b>
TB121	48	<b>90</b>
TB121	53	<b>99</b>
TB122	248	<b>430</b>
TB122	248	<b>431</b>
TB122	249	<b>433</b>
TB126	81	<b>166</b>
TB126	81	<b>167</b>
TB126	300	<b>522</b>
TB126	302	<b>526</b>
TB126	303	<b>527</b>
TB126	303	<b>528</b>
TB126	304	<b>529</b>
TB126	305	<b>530</b>
TB126	305	<b>531</b>
TB126	306	<b>532</b>
TB126	307	<b>533</b>
TB126	308	<b>534</b>
TB126	309	<b>535</b>
TB126	309	<b>536</b>
TB126	310	<b>538</b>
TB126	311	<b>539</b>
TB129	2	<b>1</b>
TB129	2	<b>2</b>
TB129	3	<b>3</b>
TB129	15	<b>35</b>
TB129	16	<b>36</b>
TB129	17	<b>37</b>
TB129	18	<b>38</b>
TB129	19	<b>39</b>
TB129	20	<b>40</b>
TB129	21	<b>41</b>
TB129	64	<b>124</b>
TB129	66	<b>128</b>
TB134	78	<b>161</b>
TB134	79	<b>163</b>

		9
TB134	337	<b>593</b>
TB134	337	<b>594</b>
TB134	338	<b>595</b>
TB134	396	<b>688</b>
TB134	396	<b>689</b>
TB134	397	<b>690</b>
TB134	400	<b>697</b>
TB134	401	<b>698</b>
TB135	345	<b>612</b>
TB135	350	<b>618</b>
TB135	352	<b>620</b>
TB135	359	<b>631</b>
TB135	390	<b>679</b>
TB135	394	<b>684</b>
TB143	50	<b>94</b>
TB143	51	<b>95</b>
TB143	52	<b>96</b>
TB146	331	<b>577</b>
TB148	226	<b>378</b>
TB148	248	<b>430</b>
TB148	248	<b>431</b>
TB150	198	<b>328</b>
TB175	201	<b>333</b>
TB186	180	<b>306</b>
TB192	243	<b>414</b>
TB192	246	<b>424</b>
TB200	226	<b>378</b>
TB200	226	<b>379</b>
TB200	227	<b>380</b>
TB200	227	<b>381</b>
TB200	228	<b>383</b>
TB200	229	<b>386</b>
TB200	230	<b>387</b>
TB246	228	<b>384</b>
TB247	49	<b>93</b>
TB247	53	<b>100</b>
TB247	54	<b>101</b>
TB247	299	<b>521</b>
TB248	49	<b>91</b>
TB248	53	<b>98</b>
TB248	65	<b>125</b>
TB248	65	<b>126</b>
TB248	66	<b>127</b>
TB248	300	<b>522</b>
TB248	302	<b>526</b>
TB248	303	<b>527</b>
TB248	303	<b>528</b>
TB248	304	<b>529</b>
TB248	305	<b>530</b>
TB248	306	<b>532</b>
TB248	307	<b>533</b>
TB249	226	<b>379</b>
TB249	227	<b>380</b>
TB249	227	<b>381</b>
TB249	228	<b>382</b>
TB249	228	<b>383</b>
TB249	230	<b>388</b>
TB249	230	<b>389</b>
TB249	231	<b>390</b>
TB249	231	<b>391</b>

# NUMERICAL PARTS LIST

Numerische Teilenummernliste • Elenco riferimenti  
Liste des références produits

			<b>9</b>
TB249	232	<b>392</b>	
TB250	347	<b>614</b>	
TB250	349	<b>617</b>	
TB250	355	<b>624</b>	
TB250	357	<b>626</b>	
TB250	363	<b>635</b>	
TB250	364	<b>637</b>	
TB250	367	<b>641</b>	
TB250	373	<b>652</b>	
TB250	378	<b>660</b>	
TB250	380	<b>663</b>	
TB274	328	<b>568</b>	
TB274	328	<b>569</b>	
TB278	189	<b>318</b>	
TB278	190	<b>319</b>	
TB278	191	<b>320</b>	
TB286	181	<b>307</b>	
TB286	182	<b>310</b>	
TB298	236	<b>400</b>	
TB299	234	<b>398</b>	
TB299	235	<b>399</b>	
TB299	238	<b>403</b>	
TB299	241	<b>409</b>	
TB303	234	<b>398</b>	
TB303	235	<b>399</b>	
TB303	236	<b>401</b>	
TB303	237	<b>402</b>	
TB303	238	<b>403</b>	
TB303	239	<b>404</b>	
TB303	239	<b>405</b>	
TB303	240	<b>406</b>	
TB303	240	<b>407</b>	
TB303	241	<b>408</b>	
TB303	241	<b>409</b>	
TB303	242	<b>410</b>	
TB303	250	<b>434</b>	
TB303	251	<b>435</b>	
TB303	251	<b>436</b>	
TB303	252	<b>437</b>	
TB303	253	<b>438</b>	
TB303	254	<b>440</b>	
TB303	255	<b>441</b>	
TB303	258	<b>447</b>	
TB303	259	<b>448</b>	
TB303	259	<b>449</b>	
TB303	262	<b>453</b>	
TB303	263	<b>454</b>	
TB303	264	<b>455</b>	
TB303	265	<b>456</b>	
TB303	266	<b>457</b>	
TB303	267	<b>458</b>	
TB303	268	<b>460</b>	
TB303	269	<b>462</b>	
TB303	269	<b>463</b>	
TB303	270	<b>464</b>	
TB303	272	<b>466</b>	
TB303	273	<b>469</b>	
TB303	274	<b>470</b>	
TB303	274	<b>471</b>	
TB303	275	<b>472</b>	

			<b>9</b>
TB303	275	<b>473</b>	
TB305	82	<b>168</b>	
TB305	82	<b>169</b>	
TB305	83	<b>170</b>	
TB305	83	<b>171</b>	
TB305	84	<b>172</b>	
TB305	85	<b>173</b>	
TB305	85	<b>174</b>	
TB305	86	<b>175</b>	
TB305	86	<b>176</b>	
TB305	87	<b>177</b>	
TB305	87	<b>178</b>	
TB305	310	<b>538</b>	
TB305	311	<b>539</b>	
TB305	311	<b>540</b>	
TB305	312	<b>541</b>	
TB305	312	<b>542</b>	
TB305	313	<b>543</b>	
TB305	313	<b>544</b>	
TB305	314	<b>545</b>	
TB305	314	<b>546</b>	
TB305	315	<b>547</b>	
TB305	321	<b>558</b>	
TB305	322	<b>559</b>	
TB305	323	<b>560</b>	
TB305	324	<b>561</b>	
TB305	325	<b>562</b>	
TB306	173	<b>296</b>	
TB306	181	<b>308</b>	
TB307	183	<b>311</b>	
TB307	184	<b>312</b>	
TB307	185	<b>313</b>	
TB307	186	<b>314</b>	
TB307	187	<b>315</b>	
TB307	188	<b>316</b>	
TB307	194	<b>323</b>	
TB307	195	<b>324</b>	
TB307	196	<b>325</b>	
TB307	197	<b>326</b>	
TB320	288	<b>499</b>	
TB320	289	<b>500</b>	
TB337	172	<b>295</b>	
TB337	174	<b>299</b>	
TB337	175	<b>300</b>	
TB337	176	<b>301</b>	
TB337	177	<b>302</b>	
TB337	178	<b>303</b>	
TB337	179	<b>304</b>	
TB338	70	<b>139</b>	
TB338	71	<b>140</b>	
TB338	219	<b>364</b>	
TB338	221	<b>368</b>	
TB338	222	<b>369</b>	
TB338	232	<b>393</b>	
TB338	325	<b>563</b>	
TB338	326	<b>564</b>	
TB338	326	<b>565</b>	
TB338	327	<b>566</b>	
TB346	199	<b>330</b>	
TB346	294	<b>510</b>	

			<b>9</b>
TB346	296	<b>514</b>	
TB346	296	<b>515</b>	
TB348	361	<b>633</b>	
TB348	362	<b>634</b>	
TB348	382	<b>667</b>	
TB348	383	<b>668</b>	
TB348	384	<b>670</b>	
TB348	391	<b>680</b>	
TB348	392	<b>681</b>	
TB348	393	<b>682</b>	
TB349	174	<b>298</b>	
TB350	180	<b>306</b>	
TB351	179	<b>305</b>	
TB351	180	<b>306</b>	
TB351	192	<b>321</b>	
TB351	193	<b>322</b>	
TB352	179	<b>305</b>	
TB352	180	<b>306</b>	
TB352	192	<b>321</b>	
TB352	193	<b>322</b>	
TB368	390	<b>679</b>	
TB368	394	<b>684</b>	
TB368	416	<b>731</b>	
TB383	77	<b>159</b>	
TB383	79	<b>162</b>	
TB383	337	<b>592</b>	
TB383	340	<b>601</b>	
TB383	340	<b>602</b>	
TB383	341	<b>603</b>	
TB383	395	<b>685</b>	
TB383	397	<b>691</b>	
TB383	401	<b>699</b>	
TB383	402	<b>701</b>	
TB383	403	<b>705</b>	
TB388	53	<b>100</b>	
TB388	222	<b>370</b>	
TB388	388	<b>676</b>	
TB394	260	<b>451</b>	
TB394	268	<b>461</b>	
TB394	271	<b>465</b>	
TB419	199	<b>330</b>	
TB419	294	<b>510</b>	
TB419	296	<b>514</b>	
TB419	296	<b>515</b>	
TB454	293	<b>509</b>	
TB454	295	<b>513</b>	
TB462	146	<b>258</b>	
TB462	147	<b>259</b>	
TB462	148	<b>260</b>	
TB462	150	<b>262</b>	
TB462	151	<b>263</b>	
TB462	153	<b>266</b>	
TB462	154	<b>267</b>	
TB468	97	<b>194</b>	
TB468	98	<b>195</b>	
TB468	99	<b>196</b>	
TB468	100	<b>197</b>	
TB468	101	<b>198</b>	
TB468	103	<b>200</b>	
TB468	104	<b>201</b>	

			<b>9</b>
TB468	104	<b>202</b>	
TB468	105	<b>203</b>	
TB468	107	<b>205</b>	
TB468	108	<b>206</b>	
TB468	108	<b>207</b>	
TB468	206	<b>343</b>	
TB468	206	<b>344</b>	
TB468	207	<b>345</b>	
TB468	208	<b>346</b>	
TB468	209	<b>348</b>	
TB468	210	<b>349</b>	
TB468	211	<b>350</b>	
TB468	212	<b>351</b>	
TB468	212	<b>352</b>	
TB468	213	<b>354</b>	
TB468	214	<b>355</b>	
TB468	216	<b>357</b>	
TB470	90	<b>184</b>	
TB470	91	<b>185</b>	
TB470	91	<b>186</b>	
TB471	88	<b>180</b>	
TB471	89	<b>181</b>	
TB471	315	<b>548</b>	
TB471	317	<b>551</b>	
TB471	317	<b>552</b>	
TB471	318	<b>553</b>	
TB471	319	<b>555</b>	
TB471	319	<b>556</b>	
TB471	320	<b>557</b>	
TB474	254	<b>439</b>	
TB474	255	<b>442</b>	
TB474	256	<b>443</b>	
TB474	256	<b>444</b>	
TB474	260	<b>450</b>	
TB474	260	<b>451</b>	
TB474	261	<b>452</b>	
TB474	268	<b>461</b>	
TB474	271	<b>465</b>	
TB474	272	<b>467</b>	
TB474	273	<b>468</b>	
TB474	276	<b>474</b>	
TB474	277	<b>475</b>	
TB474	278	<b>476</b>	
TB474	279	<b>478</b>	
TB474	281	<b>482</b>	
TB479	294	<b>511</b>	
TB479	295	<b>512</b>	
TB515	56	<b>106</b>	
TB528	92	<b>187</b>	
TB528	93	<b>189</b>	
TB528	94	<b>190</b>	
TB528	95	<b>191</b>	
TB528	96	<b>193</b>	
TB531	395	<b>686</b>	
TB531	401	<b>700</b>	
TB531	402	<b>702</b>	
TB531	403	<b>703</b>	
TB531	403	<b>704</b>	
TB532	338	<b>597</b>	
TB532	339	<b>598</b>	

		<b>9</b>
<b>TB532</b>	339	<b>599</b>
<b>TB532</b>	395	<b>686</b>
<b>TB532</b>	395	<b>687</b>
<b>TB532</b>	398	<b>692</b>
<b>TB532</b>	398	<b>693</b>
<b>TB532</b>	399	<b>694</b>
<b>TB532</b>	399	<b>695</b>
<b>TB532</b>	400	<b>696</b>
<b>TB532</b>	404	<b>707</b>
<b>TB532</b>	404	<b>708</b>
<b>TB532</b>	405	<b>709</b>
<b>TB558</b>	413	<b>724</b>
<b>TB558</b>	416	<b>731</b>
<b>TB558</b>	419	<b>736</b>
<b>TB560</b>	200	<b>331</b>
<b>TB560</b>	201	<b>333</b>
<b>TB560</b>	202	<b>334</b>
<b>TB560</b>	203	<b>336</b>
<b>TB560</b>	204	<b>339</b>
<b>TB577</b>	51	<b>95</b>
<b>TB579</b>	164	<b>278</b>
<b>TB579</b>	234	<b>398</b>
<b>TB579</b>	235	<b>399</b>
<b>TB579</b>	236	<b>400</b>
<b>TB579</b>	236	<b>401</b>
<b>TB579</b>	237	<b>402</b>
<b>TB579</b>	239	<b>404</b>
<b>TB579</b>	240	<b>407</b>
<b>TB579</b>	241	<b>408</b>
<b>TB579</b>	250	<b>434</b>
<b>TB579</b>	251	<b>435</b>
<b>TB579</b>	251	<b>436</b>
<b>TB579</b>	252	<b>437</b>
<b>TB579</b>	253	<b>438</b>
<b>TB579</b>	254	<b>439</b>
<b>TB579</b>	255	<b>441</b>
<b>TB579</b>	256	<b>443</b>
<b>TB579</b>	256	<b>444</b>
<b>TB579</b>	258	<b>447</b>
<b>TB579</b>	259	<b>448</b>
<b>TB579</b>	259	<b>449</b>
<b>TB579</b>	260	<b>450</b>
<b>TB579</b>	260	<b>451</b>
<b>TB579</b>	261	<b>452</b>
<b>TB579</b>	262	<b>453</b>
<b>TB579</b>	263	<b>454</b>
<b>TB579</b>	264	<b>455</b>
<b>TB579</b>	265	<b>456</b>
<b>TB579</b>	266	<b>457</b>
<b>TB579</b>	267	<b>458</b>
<b>TB579</b>	267	<b>459</b>
<b>TB579</b>	268	<b>460</b>
<b>TB579</b>	268	<b>461</b>
<b>TB579</b>	269	<b>462</b>
<b>TB579</b>	269	<b>463</b>
<b>TB579</b>	270	<b>464</b>
<b>TB579</b>	271	<b>465</b>
<b>TB579</b>	272	<b>466</b>
<b>TB579</b>	272	<b>467</b>
<b>TB579</b>	273	<b>468</b>

		<b>9</b>
<b>TB579</b>	274	<b>470</b>
<b>TB579</b>	274	<b>471</b>
<b>TB579</b>	275	<b>472</b>
<b>TB579</b>	275	<b>473</b>
<b>TB579</b>	276	<b>474</b>
<b>TB579</b>	277	<b>475</b>
<b>TB579</b>	278	<b>476</b>
<b>TB579</b>	279	<b>478</b>
<b>TB579</b>	280	<b>480</b>
<b>TB579</b>	281	<b>482</b>
<b>TB607</b>	207	<b>345</b>
<b>TB607</b>	208	<b>346</b>
<b>TB607</b>	212	<b>351</b>
<b>TB607</b>	212	<b>352</b>
<b>TB608</b>	109	<b>208</b>
<b>TB608</b>	110	<b>209</b>
<b>TB608</b>	112	<b>211</b>
<b>TB608</b>	117	<b>217</b>
<b>TB608</b>	127	<b>230</b>
<b>TB608</b>	156	<b>269</b>
<b>TB608</b>	158	<b>271</b>
<b>TB631</b>	172	<b>294</b>
<b>TB632</b>	285	<b>494</b>
<b>TB632</b>	287	<b>497</b>
<b>TB632</b>	288	<b>498</b>
<b>TB637</b>	28	<b>51</b>
<b>TB637</b>	28	<b>52</b>
<b>TB637</b>	31	<b>57</b>
<b>TB637</b>	34	<b>60</b>
<b>TB637</b>	35	<b>61</b>
<b>TB637</b>	38	<b>65</b>
<b>TB637</b>	39	<b>66</b>
<b>TB637</b>	40	<b>69</b>
<b>TB637</b>	42	<b>73</b>
<b>TB637</b>	44	<b>77</b>
<b>TB639</b>	109	<b>208</b>
<b>TB639</b>	111	<b>210</b>
<b>TB639</b>	112	<b>211</b>
<b>TB639</b>	113	<b>212</b>
<b>TB639</b>	114	<b>213</b>
<b>TB639</b>	115	<b>214</b>
<b>TB639</b>	115	<b>215</b>
<b>TB639</b>	116	<b>216</b>
<b>TB639</b>	118	<b>218</b>
<b>TB639</b>	119	<b>219</b>
<b>TB639</b>	120	<b>220</b>
<b>TB639</b>	121	<b>221</b>
<b>TB639</b>	122	<b>222</b>
<b>TB639</b>	124	<b>225</b>
<b>TB639</b>	125	<b>226</b>
<b>TB639</b>	126	<b>228</b>
<b>TB639</b>	126	<b>229</b>
<b>TB639</b>	128	<b>231</b>
<b>TB639</b>	128	<b>232</b>
<b>TB639</b>	129	<b>233</b>
<b>TB639</b>	130	<b>235</b>
<b>TB639</b>	131	<b>236</b>
<b>TB639</b>	132	<b>237</b>
<b>TB639</b>	135	<b>243</b>
<b>TB639</b>	135	<b>244</b>

		<b>9</b>
<b>TB639</b>	136	<b>246</b>
<b>TB639</b>	137	<b>247</b>
<b>TB639</b>	139	<b>250</b>
<b>TB639</b>	141	<b>253</b>
<b>TB639</b>	142	<b>254</b>
<b>TB639</b>	143	<b>255</b>
<b>TB639</b>	144	<b>256</b>
<b>TB639</b>	145	<b>257</b>
<b>TB639</b>	157	<b>270</b>
<b>TB639</b>	159	<b>272</b>
<b>TB639</b>	160	<b>273</b>
<b>TB639</b>	161	<b>274</b>
<b>TB639</b>	162	<b>275</b>
<b>TB639</b>	163	<b>276</b>
<b>TB639</b>	164	<b>277</b>
<b>TB639</b>	169	<b>289</b>
<b>TB639</b>	170	<b>290</b>
<b>TB649</b>	24	<b>47</b>
<b>TB649</b>	25	<b>48</b>
<b>TB649</b>	26	<b>49</b>
<b>TB649</b>	27	<b>50</b>
<b>TB649</b>	29	<b>53</b>
<b>TB649</b>	29	<b>54</b>
<b>TB649</b>	30	<b>55</b>
<b>TB649</b>	30	<b>56</b>
<b>TB649</b>	32	<b>58</b>
<b>TB649</b>	33	<b>59</b>
<b>TB649</b>	37	<b>63</b>
<b>TB660</b>	24	<b>47</b>
<b>TB660</b>	25	<b>48</b>
<b>TB660</b>	26	<b>49</b>
<b>TB660</b>	27	<b>50</b>
<b>TB660</b>	29	<b>53</b>
<b>TB660</b>	30	<b>56</b>
<b>TB660</b>	38	<b>64</b>
<b>TB676</b>	16	<b>36</b>
<b>TB676</b>	17	<b>37</b>
<b>TB676</b>	18	<b>38</b>
<b>TB676</b>	19	<b>39</b>
<b>TB676</b>	20	<b>40</b>
<b>TB676</b>	21	<b>41</b>
<b>TB676</b>	64	<b>124</b>
<b>TB676</b>	66	<b>128</b>
<b>TB678</b>	291	<b>504</b>
<b>TB678</b>	291	<b>505</b>
<b>TB683</b>	282	<b>485</b>
<b>TB683</b>	282	<b>486</b>
<b>TB683</b>	283	<b>487</b>
<b>TB701</b>	385	<b>672</b>
<b>TB701</b>	386	<b>674</b>
<b>TB701</b>	387	<b>675</b>
<b>TB701</b>	420	<b>737</b>
<b>TB703</b>	78	<b>160</b>
<b>TB720</b>	284	<b>490</b>
<b>TB720</b>	284	<b>491</b>
<b>TB720</b>	286	<b>495</b>
<b>TB720</b>	286	<b>496</b>
<b>TB723</b>	332	<b>580</b>
<b>TB723</b>	333	<b>582</b>
<b>TB723</b>	334	<b>585</b>

		<b>9</b>
<b>TB723</b>	335	<b>586</b>
<b>TB724</b>	47	<b>86</b>
<b>TB725</b>	123	<b>223</b>
<b>TB725</b>	124	<b>224</b>
<b>TB725</b>	132	<b>238</b>
<b>TB725</b>	133	<b>239</b>
<b>TB725</b>	134	<b>241</b>
<b>TB725</b>	164	<b>278</b>
<b>TB725</b>	165	<b>279</b>
<b>TB725</b>	165	<b>281</b>
<b>TB725</b>	166	<b>282</b>
<b>TB727</b>	329	<b>570</b>
<b>TB727</b>	329	<b>572</b>
<b>TB732</b>	209	<b>348</b>
<b>TB741</b>	89	<b>182</b>
<b>TB742</b>	281	<b>483</b>
<b>TB742</b>	283	<b>489</b>
<b>TB742</b>	284	<b>492</b>
<b>TB742</b>	285	<b>493</b>
<b>TB787</b>	23	<b>45</b>
<b>TB787</b>	29	<b>54</b>
<b>TB787</b>	30	<b>55</b>
<b>TB787</b>	32	<b>58</b>
<b>TB787</b>	33	<b>59</b>
<b>TB787</b>	36	<b>62</b>
<b>TB787</b>	37	<b>63</b>
<b>TB787</b>	43	<b>76</b>
<b>TB790</b>	133	<b>240</b>
<b>TB790</b>	134	<b>241</b>
<b>TB790</b>	136	<b>245</b>
<b>TB790</b>	138	<b>248</b>
<b>TB790</b>	139	<b>249</b>
<b>TB790</b>	140	<b>251</b>
<b>TB790</b>	166	<b>284</b>
<b>TB790</b>	167	<b>285</b>
<b>TB790</b>	167	<b>286</b>
<b>TB790</b>	168	<b>287</b>
<b>TB790</b>	168	<b>288</b>
<b>TBK006</b>	2	<b>1</b>
<b>TBK006</b>	2	<b>2</b>
<b>TBK006</b>	3	<b>3</b>
<b>TBK006</b>	15	<b>35</b>
<b>TBK006</b>	16	<b>36</b>
<b>TBK006</b>	17	<b>37</b>
<b>TBK006</b>	18	<b>38</b>
<b>TBK006</b>	19	<b>39</b>
<b>TBK006</b>	20	<b>40</b>
<b>TBK006</b>	21	<b>41</b>
<b>TBK006</b>	64	<b>124</b>
<b>TBK006</b>	66	<b>128</b>
<b>TBK010</b>	199	<b>330</b>
<b>TBK010</b>	294	<b>510</b>
<b>TBK010</b>	296	<b>514</b>
<b>TBK010</b>	296	<b>515</b>
<b>TBK020</b>	200	<b>331</b>
<b>TBK020</b>	201	<b>333</b>
<b>TBK020</b>	202	<b>334</b>
<b>TBK020</b>	203	<b>336</b>
<b>TBK020</b>	204	<b>339</b>
<b>TBK027</b>	82	<b>168</b>

# NUMERICAL PARTS LIST

Nummerische Teilenummernliste • Elenco riferimenti  
Liste des références produits

 <span style="border: 1px solid black; padding: 2px;">9</span>		
TBK027	82	<b>169</b>
TBK027	83	<b>170</b>
TBK027	83	<b>171</b>
TBK027	84	<b>172</b>
TBK027	85	<b>173</b>
TBK027	85	<b>174</b>
TBK027	86	<b>175</b>
TBK027	87	<b>178</b>
TBK027	310	<b>538</b>
TBK027	311	<b>539</b>
TBK027	311	<b>540</b>
TBK027	312	<b>541</b>
TBK027	312	<b>542</b>
TBK027	313	<b>543</b>
TBK027	313	<b>544</b>
TBK027	314	<b>545</b>
TBK027	314	<b>546</b>
TBK027	315	<b>547</b>
TBK027	321	<b>558</b>
TBK027	322	<b>559</b>
TBK027	323	<b>560</b>
TBK027	324	<b>561</b>
TBK027	325	<b>562</b>
TBK035	288	<b>499</b>
TBK035	289	<b>500</b>
TBK037	388	<b>676</b>
TBK037	390	<b>679</b>
TBK037	394	<b>684</b>
TBK037	416	<b>731</b>
TBK039	385	<b>672</b>
TBK039	386	<b>674</b>
TBK039	387	<b>675</b>
TBK039	420	<b>737</b>
TBK040	172	<b>295</b>
TBK040	174	<b>299</b>
TBK040	175	<b>300</b>
TBK040	176	<b>301</b>
TBK040	177	<b>302</b>
TBK040	178	<b>303</b>
TBK040	179	<b>304</b>
TBK045	345	<b>612</b>
TBK045	350	<b>618</b>
TBK045	359	<b>631</b>
TBK045	390	<b>679</b>
TBK045	394	<b>684</b>
TBK063	355	<b>624</b>
TBK063	357	<b>626</b>
TBK065	183	<b>311</b>
TBK065	184	<b>312</b>
TBK065	185	<b>313</b>
TBK065	186	<b>314</b>
TBK065	187	<b>315</b>
TBK065	188	<b>316</b>
TBK065	194	<b>323</b>
TBK065	195	<b>324</b>
TBK065	196	<b>325</b>
TBK065	197	<b>326</b>
TBK085	24	<b>47</b>
TBK085	25	<b>48</b>
TBK085	26	<b>49</b>

 <span style="border: 1px solid black; padding: 2px;">9</span>		
TBK085	27	<b>50</b>
TBK085	29	<b>53</b>
TBK085	30	<b>56</b>
TBK085	38	<b>64</b>
TBK089	88	<b>180</b>
TBK089	89	<b>181</b>
TBK089	315	<b>548</b>
TBK089	317	<b>551</b>
TBK089	317	<b>552</b>
TBK089	318	<b>553</b>
TBK089	319	<b>555</b>
TBK089	319	<b>556</b>
TBK089	320	<b>557</b>
TBK094	110	<b>209</b>
TBK094	117	<b>217</b>
TBK094	127	<b>230</b>
TBK102	413	<b>724</b>
TBK102	416	<b>731</b>
TBK102	419	<b>736</b>
TBK104	109	<b>208</b>
TBK104	112	<b>211</b>
TBK104	129	<b>233</b>
TBK104	141	<b>253</b>
TBK104	157	<b>270</b>
TBK104	159	<b>272</b>
TBK104	160	<b>273</b>
TBK104	161	<b>274</b>
TBK104	162	<b>275</b>
TBK104	163	<b>276</b>
TBK104	164	<b>277</b>
TBK104	169	<b>289</b>
TBK104	170	<b>290</b>
TBK105	172	<b>294</b>
TBK106	285	<b>494</b>
TBK106	287	<b>497</b>
TBK113	295	<b>512</b>
TBK118	234	<b>398</b>
TBK118	235	<b>399</b>
TBK118	236	<b>401</b>
TBK118	237	<b>402</b>
TBK118	238	<b>403</b>
TBK118	239	<b>404</b>
TBK118	239	<b>405</b>
TBK118	240	<b>406</b>
TBK118	240	<b>407</b>
TBK118	241	<b>408</b>
TBK118	241	<b>409</b>
TBK118	242	<b>410</b>
TBK118	254	<b>440</b>
TBK118	255	<b>441</b>
TBK118	259	<b>448</b>
TBK118	259	<b>449</b>
TBK118	267	<b>458</b>
TBK118	268	<b>460</b>
TBK118	269	<b>463</b>
TBK118	272	<b>466</b>
TBK118	273	<b>469</b>
TBK118	274	<b>470</b>
TBK118	274	<b>471</b>
TBK118	275	<b>472</b>

 <span style="border: 1px solid black; padding: 2px;">9</span>		
TBK118	275	<b>473</b>
TBK207	93	<b>189</b>
TBK207	94	<b>190</b>
TBK207	95	<b>191</b>
TBK207	96	<b>193</b>
TBK274	287	<b>497</b>
TBK274	288	<b>498</b>
TBK277	24	<b>47</b>
TBK277	25	<b>48</b>
TBK277	26	<b>49</b>
TBK277	27	<b>50</b>
TBK277	29	<b>53</b>
TBK277	29	<b>54</b>
TBK277	30	<b>55</b>
TBK277	30	<b>56</b>
TBK277	32	<b>58</b>
TBK277	33	<b>59</b>
TBK277	37	<b>63</b>
TBK279	282	<b>485</b>
TBK279	282	<b>486</b>
TBK279	283	<b>487</b>
TBK283	109	<b>208</b>
TBK283	111	<b>210</b>
TBK283	112	<b>211</b>
TBK283	113	<b>212</b>
TBK283	114	<b>213</b>
TBK283	115	<b>214</b>
TBK283	115	<b>215</b>
TBK283	116	<b>216</b>
TBK283	118	<b>218</b>
TBK283	119	<b>219</b>
TBK283	120	<b>220</b>
TBK283	121	<b>221</b>
TBK283	122	<b>222</b>
TBK283	124	<b>225</b>
TBK283	126	<b>228</b>
TBK283	126	<b>229</b>
TBK283	128	<b>231</b>
TBK283	128	<b>232</b>
TBK283	129	<b>233</b>
TBK283	130	<b>235</b>
TBK283	131	<b>236</b>
TBK283	132	<b>237</b>
TBK283	135	<b>244</b>
TBK283	137	<b>247</b>
TBK283	139	<b>250</b>
TBK283	142	<b>254</b>
TBK283	143	<b>255</b>
TBK283	144	<b>256</b>
TBK287	70	<b>139</b>
TBK287	71	<b>140</b>
TBK287	219	<b>364</b>
TBK287	221	<b>368</b>
TBK287	222	<b>369</b>
TBK287	222	<b>370</b>
TBK287	232	<b>393</b>
TBK287	325	<b>563</b>
TBK287	326	<b>564</b>
TBK287	326	<b>565</b>
TBK287	327	<b>566</b>

 <span style="border: 1px solid black; padding: 2px;">9</span>		
TBK300	90	<b>184</b>
TBK300	91	<b>185</b>
TBK300	91	<b>186</b>
TBK303	291	<b>504</b>
TBK303	291	<b>505</b>
TBK306	133	<b>240</b>
TBK306	134	<b>241</b>
TBK306	136	<b>245</b>
TBK306	138	<b>248</b>
TBK306	139	<b>249</b>
TBK306	140	<b>251</b>
TBK313	28	<b>51</b>
TBK313	28	<b>52</b>
TBK313	31	<b>57</b>
TBK313	34	<b>60</b>
TBK313	35	<b>61</b>
TBK313	38	<b>65</b>
TBK313	39	<b>66</b>
TBK313	40	<b>69</b>
TBK313	42	<b>73</b>
TBK313	44	<b>77</b>
TBK314	16	<b>36</b>
TBK314	17	<b>37</b>
TBK314	18	<b>38</b>
TBK314	19	<b>39</b>
TBK314	20	<b>40</b>
TBK314	21	<b>41</b>
TBK314	64	<b>124</b>
TBK314	66	<b>128</b>
TBK338	281	<b>483</b>
TBK338	283	<b>489</b>
TBK338	284	<b>492</b>
TBK338	285	<b>493</b>
TBK344	293	<b>509</b>
TBK344	295	<b>513</b>
TBK345	93	<b>189</b>
TBK345	94	<b>190</b>
TBK345	95	<b>192</b>
TBK345	96	<b>193</b>
TBK345	101	<b>198</b>
TBK345	102	<b>199</b>
TBK345	106	<b>204</b>
TBK350	123	<b>223</b>
TBK350	124	<b>224</b>
TBK350	132	<b>238</b>
TBK350	133	<b>239</b>
TBK350	134	<b>241</b>
TBK352	109	<b>208</b>
TBK352	112	<b>211</b>
TBK352	127	<b>230</b>
TBK352	156	<b>269</b>
TBK352	158	<b>271</b>
TBK355	291	<b>504</b>
TBK355	291	<b>505</b>
TBK356	98	<b>195</b>
TBK356	99	<b>196</b>
TBK356	100	<b>197</b>
TBK356	105	<b>203</b>
TBK356	108	<b>206</b>
TBK356	108	<b>207</b>





9			9			9			9		
TBK356	208	346	V90070	225	376	V90392	67	130	V91273	46	85
TBK356	209	348	V90070	226	378	V90392	68	133	V91275	199	330
TBK356	210	349	V90070	229	385	V90392	69	136	V91277	199	330
TBK356	211	350	V90070	229	386	V90392	70	138	V91282	4	5
TBK356	212	351	V90070	230	389	V90392	71	141	V91282	4	6
TBK356	212	352	V90070	231	390	V90392	218	362	V91282	5	8
V3251	59	115	V90070	231	391	V90392	220	365	V91282	5	9
V3252	59	115	V90070	233	395	V90397	305	531	V91282	6	10
V34457	4	5	V90070	233	396	V90397	308	534	V91282	6	11
V34457	4	6	V90070	247	429	V90397	309	535	V91282	7	13
V34457	5	8	V90070	249	433	V90397	309	536	V91282	7	14
V34457	5	9	V90070	250	434	V90398	48	89	V91282	8	15
V34457	6	10	V90070	251	435	V90398	48	90	V91282	9	17
V34457	6	11	V90070	253	438	V90398	49	93	V91286	2	1
V34457	8	16	V90070	257	445	V90398	53	98	V91286	2	2
V34457	9	17	V90070	258	447	V90398	53	100	V91286	3	3
V34457	9	20	V90070	262	453	V90398	54	101	V91287	2	1
V34459	331	576	V90070	263	454	V90398	65	126	V91287	2	2
V34460	331	576	V90070	264	455	V90398	66	127	V91287	3	3
V34496	60	118	V90070	265	456	V90398	299	521	V91288	15	35
V34496	61	119	V90070	266	457	V90399	47	88	V91288	16	36
V34496	61	120	V90070	267	458	V90399	48	89	V91288	17	37
V34496	62	121	V90070	267	459	V90399	48	90	V91288	20	40
V34496	62	122	V90070	270	464	V90399	49	93	V91288	22	43
V34496	63	123	V90071	60	118	V90399	53	98	V91288	24	47
V34496	64	124	V90071	61	119	V90399	53	100	V91288	27	50
V34496	65	125	V90071	61	120	V90399	54	101	V91288	38	64
V34496	292	506	V90071	62	121	V90399	65	126	V91289	15	35
V34496	292	507	V90071	62	122	V90399	66	127	V91289	16	36
V34496	298	519	V90071	63	123	V90399	299	521	V91289	17	37
V34496	298	520	V90071	64	124	V90402	331	577	V91289	18	38
V34496	300	522	V90071	65	125	V90402	354	622	V91289	19	39
V34496	301	523	V90071	83	170	V90402	354	623	V91289	20	40
V34496	301	524	V90071	83	171	V90402	358	628	V91289	21	41
V34496	302	525	V90071	84	172	V90402	358	629	V91289	22	43
V34496	302	526	V90071	85	173	V90402	359	630	V91289	24	47
V34496	303	527	V90071	85	174	V90402	359	631	V91289	25	48
V34496	303	528	V90071	87	178	V90404	331	577	V91289	26	49
V34496	304	529	V90071	292	506	V90404	354	622	V91289	27	50
V34496	305	530	V90071	292	507	V90404	354	623	V91289	30	56
V34496	305	531	V90071	298	519	V90404	357	627	V91289	32	58
V34496	306	532	V90071	298	520	V90404	358	628	V91289	33	59
V34496	307	533	V90071	300	522	V90404	358	629	V91289	37	63
V34496	308	534	V90071	301	523	V90404	359	630	V91289	38	64
V34496	309	535	V90071	302	526	V90404	359	631	V91290	229	386
V34496	309	536	V90071	321	558	V91144	171	292	V91290	230	389
V34496	310	538	V90071	322	559	V91144	172	294	V91290	231	390
V34496	311	539	V90071	323	560	V91144	200	331	V91290	231	391
V34654	8	16	V90071	324	561	V91144	201	333	V91290	234	398
V90064	47	88	V90071	325	562	V91144	202	334	V91290	235	399
V90064	48	89	V90388	56	107	V91144	203	336	V91290	236	401
V90064	48	90	V90388	57	108	V91144	204	339	V91290	237	402
V90064	54	101	V90388	57	109	V91145	171	292	V91290	238	403
V90070	72	145	V90388	57	110	V91145	172	294	V91290	239	404
V90070	72	146	V90388	58	112	V91145	200	331	V91290	239	405
V90070	73	148	V90388	71	142	V91145	201	333	V91290	240	406
V90070	74	151	V90388	74	152	V91145	202	334	V91290	241	408
V90070	223	373	V90388	75	154	V91145	203	336	V91290	241	409
V90070	224	374	V90388	75	155	V91145	204	339	V91290	242	410
V90070	224	375	V90388	76	157	V91271	46	85	V91290	242	411

# NUMERICAL PARTS LIST

Numerische Teilenummernliste • Elenco riferimenti  
 Liste des références produits

 <b>9</b>		
V91290	249	<b>433</b>
V91290	250	<b>434</b>
V91290	251	<b>435</b>
V91290	253	<b>438</b>
V91290	258	<b>447</b>
V91290	259	<b>448</b>
V91290	259	<b>449</b>
V91290	260	<b>450</b>
V91290	262	<b>453</b>
V91290	263	<b>454</b>
V91290	264	<b>455</b>
V91290	265	<b>456</b>
V91290	266	<b>457</b>
V91290	267	<b>458</b>
V91290	267	<b>459</b>
V91290	269	<b>462</b>
V91290	269	<b>463</b>
V91290	270	<b>464</b>
V91290	274	<b>470</b>
V91290	274	<b>471</b>
V91290	280	<b>480</b>
V91291	183	<b>311</b>
V91291	184	<b>312</b>
V91291	186	<b>314</b>
V91291	187	<b>315</b>
V91291	188	<b>316</b>
V91291	188	<b>317</b>
V91291	192	<b>321</b>
V91291	193	<b>322</b>
V91291	194	<b>323</b>
V91291	195	<b>324</b>
V91291	196	<b>325</b>
V91291	197	<b>326</b>
V91292	345	<b>612</b>
V91292	346	<b>613</b>
V91292	347	<b>614</b>
V91292	348	<b>615</b>
V91292	348	<b>616</b>
V91292	349	<b>617</b>
V91292	350	<b>618</b>
V91292	351	<b>619</b>
V91292	352	<b>620</b>
V91292	353	<b>621</b>
V91292	354	<b>622</b>
V91292	355	<b>624</b>
V91292	356	<b>625</b>
V91292	357	<b>626</b>
V91292	357	<b>627</b>
V91292	358	<b>628</b>
V91292	358	<b>629</b>
V91292	359	<b>630</b>
V91292	359	<b>631</b>
V91292	360	<b>632</b>
V91292	361	<b>633</b>
V91292	362	<b>634</b>
V91292	365	<b>639</b>
V91292	366	<b>640</b>
V91292	367	<b>641</b>
V91292	368	<b>642</b>
V91292	368	<b>643</b>

 <b>9</b>		
V91292	369	<b>644</b>
V91292	369	<b>645</b>
V91292	370	<b>646</b>
V91292	370	<b>647</b>
V91292	371	<b>648</b>
V91292	371	<b>649</b>
V91292	372	<b>650</b>
V91292	372	<b>651</b>
V91292	373	<b>652</b>
V91292	374	<b>653</b>
V91292	374	<b>654</b>
V91292	375	<b>655</b>
V91292	375	<b>656</b>
V91292	376	<b>657</b>
V91292	376	<b>658</b>
V91292	377	<b>659</b>
V91292	378	<b>660</b>
V91292	379	<b>661</b>
V91292	380	<b>664</b>
V91292	381	<b>665</b>
V91292	381	<b>666</b>
V91292	382	<b>667</b>
V91292	383	<b>668</b>
V91292	385	<b>672</b>
V91292	385	<b>673</b>
V91292	386	<b>674</b>
V91292	387	<b>675</b>
V91292	388	<b>676</b>
V91292	390	<b>679</b>
V91292	391	<b>680</b>
V91292	392	<b>681</b>
V91292	393	<b>682</b>
V91292	394	<b>683</b>
V91292	405	<b>710</b>
V91292	406	<b>711</b>
V91292	407	<b>712</b>
V91292	408	<b>713</b>
V91292	409	<b>715</b>
V91292	409	<b>716</b>
V91292	410	<b>717</b>
V91292	413	<b>724</b>
V91292	414	<b>725</b>
V91292	414	<b>726</b>
V91292	415	<b>727</b>
V91292	416	<b>731</b>
V91292	417	<b>732</b>
V91292	419	<b>736</b>
V91293	345	<b>612</b>
V91293	346	<b>613</b>
V91293	347	<b>614</b>
V91293	348	<b>615</b>
V91293	348	<b>616</b>
V91293	349	<b>617</b>
V91293	350	<b>618</b>
V91293	351	<b>619</b>
V91293	352	<b>620</b>
V91293	353	<b>621</b>
V91293	354	<b>622</b>
V91293	355	<b>624</b>
V91293	356	<b>625</b>

 <b>9</b>		
V91293	357	<b>626</b>
V91293	357	<b>627</b>
V91293	358	<b>628</b>
V91293	358	<b>629</b>
V91293	359	<b>630</b>
V91293	359	<b>631</b>
V91293	360	<b>632</b>
V91293	361	<b>633</b>
V91293	362	<b>634</b>
V91293	365	<b>639</b>
V91293	366	<b>640</b>
V91293	367	<b>641</b>
V91293	368	<b>642</b>
V91293	368	<b>643</b>
V91293	369	<b>645</b>
V91293	370	<b>646</b>
V91293	371	<b>648</b>
V91293	371	<b>649</b>
V91293	372	<b>650</b>
V91293	372	<b>651</b>
V91293	373	<b>652</b>
V91293	374	<b>653</b>
V91293	374	<b>654</b>
V91293	375	<b>655</b>
V91293	375	<b>656</b>
V91293	376	<b>657</b>
V91293	376	<b>658</b>
V91293	377	<b>659</b>
V91293	378	<b>660</b>
V91293	379	<b>661</b>
V91293	380	<b>664</b>
V91293	381	<b>665</b>
V91293	381	<b>666</b>
V91293	382	<b>667</b>
V91293	383	<b>668</b>
V91293	385	<b>672</b>
V91293	385	<b>673</b>
V91293	386	<b>674</b>
V91293	387	<b>675</b>
V91293	388	<b>676</b>
V91293	390	<b>679</b>
V91293	391	<b>680</b>
V91293	392	<b>681</b>
V91293	393	<b>682</b>
V91293	394	<b>683</b>
V91294	345	<b>612</b>
V91294	346	<b>613</b>
V91294	347	<b>614</b>
V91294	348	<b>615</b>
V91294	348	<b>616</b>
V91294	349	<b>617</b>
V91294	350	<b>618</b>
V91294	351	<b>619</b>
V91294	352	<b>620</b>
V91294	353	<b>621</b>
V91294	355	<b>624</b>
V91294	356	<b>625</b>
V91294	357	<b>626</b>
V91294	360	<b>632</b>
V91294	361	<b>633</b>

 <b>9</b>		
V91294	362	<b>634</b>
V91294	366	<b>640</b>
V91294	367	<b>641</b>
V91294	368	<b>642</b>
V91294	368	<b>643</b>
V91294	369	<b>644</b>
V91294	370	<b>647</b>
V91294	372	<b>650</b>
V91294	372	<b>651</b>
V91294	373	<b>652</b>
V91294	374	<b>653</b>
V91294	374	<b>654</b>
V91294	375	<b>655</b>
V91294	375	<b>656</b>
V91294	376	<b>658</b>
V91294	378	<b>660</b>
V91294	379	<b>661</b>
V91294	380	<b>664</b>
V91294	381	<b>665</b>
V91294	381	<b>666</b>
V91294	382	<b>667</b>
V91294	383	<b>668</b>
V91294	385	<b>672</b>
V91294	385	<b>673</b>
V91294	386	<b>674</b>
V91294	387	<b>675</b>
V91294	388	<b>676</b>
V91294	390	<b>679</b>
V91294	391	<b>680</b>
V91294	392	<b>681</b>
V91294	393	<b>682</b>
V91294	394	<b>683</b>
V91295	173	<b>296</b>
V91295	174	<b>299</b>
V91295	175	<b>300</b>
V91295	176	<b>301</b>
V91295	177	<b>302</b>
V91295	178	<b>303</b>
V91295	179	<b>304</b>
V91295	180	<b>306</b>
V91295	181	<b>307</b>
V91295	185	<b>313</b>
V91295	189	<b>318</b>
V91295	190	<b>319</b>
V91295	191	<b>320</b>
V91300	83	<b>170</b>
V91300	83	<b>171</b>
V91300	84	<b>172</b>
V91300	85	<b>173</b>
V91300	85	<b>174</b>
V91300	87	<b>178</b>
V91300	312	<b>541</b>
V91300	312	<b>542</b>
V91300	313	<b>543</b>
V91300	314	<b>546</b>
V91300	321	<b>558</b>
V91300	322	<b>559</b>
V91301	420	<b>738</b>
V91302	420	<b>738</b>
V91304	420	<b>738</b>

		<b>9</b>
V91305	55	105
V91305	234	398
V91305	235	399
V91305	236	401
V91305	237	402
V91305	239	404
V91305	239	405
V91305	241	408
V91305	242	410
V91306	315	547
V91306	323	560
V91306	324	561
V91306	325	562
V91307	81	166
V91307	81	167
V91307	82	168
V91307	82	169
V91307	86	175
V91308	213	353
V91308	216	358
V91308	217	359
V91308	243	412
V91308	245	422
V91308	280	481
V91321	183	311
V91321	184	312
V91321	186	314
V91321	187	315
V91321	188	316
V91321	188	317
V91321	192	321
V91321	193	322
V91321	194	323
V91321	195	324
V91321	196	325
V91321	197	326
V91392	173	296
V91392	174	299
V91392	175	300
V91392	176	301
V91392	177	302
V91392	178	303
V91392	179	304
V91392	179	305
V91392	180	306
V91392	181	307
V91392	183	311
V91392	184	312
V91392	185	313
V91392	186	314
V91392	187	315
V91392	188	316
V91392	188	317
V91392	189	318
V91392	190	319
V91392	191	320
V91392	192	321
V91392	193	322
V91392	194	323
V91392	195	324

		<b>9</b>
V91394	55	105
V91394	227	380
V91394	227	381
V91394	229	386
V91394	230	389
V91394	231	390
V91394	231	391
V91394	247	427
V91394	248	430
V91394	249	433
V91394	250	434
V91394	251	435
V91394	252	437
V91394	253	438
V91394	255	441
V91394	258	447
V91394	259	448
V91394	259	449
V91394	260	450
V91394	262	453
V91394	263	454
V91394	264	455
V91394	265	456
V91394	266	457
V91394	267	458
V91394	267	459
V91394	269	462
V91394	269	463
V91394	270	464
V91394	274	470
V91394	274	471
V91394	280	480
V91399	363	635
V91399	363	636
V91399	364	637
V91399	364	638
V91399	369	645
V91399	370	646
V91399	384	671
V91400	363	635
V91400	363	636
V91400	364	637
V91400	364	638
V91400	369	645
V91400	370	646
V91400	384	671
V91437	332	579
V91437	341	604
V91437	341	605
V91437	342	606
V91437	342	607
V91437	343	608
V91437	343	609
V91437	344	610
V91437	344	611
V91438	332	579
V91438	341	604
V91438	341	605
V91438	342	606
V91438	342	607

		<b>9</b>
V91438	343	608
V91438	343	609
V91438	344	610
V91438	344	611
V91614	69	137
V91614	219	364
V91614	221	367
V91615	69	137
V91615	219	363
V91615	219	364
V91621	325	563
V91621	326	564
V91622	328	568
V91622	328	569
V91623	328	568
V91623	328	569
V91627	221	367
V91629	68	132
V91629	70	139
V91629	71	140
V91629	217	360
V91629	218	361
V91629	220	366
V91629	221	368
V91629	222	369
V91629	222	370
V91629	232	393
V91629	325	563
V91629	326	564
V91629	326	565
V91629	327	566
V91630	68	132
V91630	70	139
V91630	71	140
V91630	217	360
V91630	218	361
V91630	220	366
V91630	221	368
V91630	222	369
V91630	222	370
V91630	222	369
V91630	222	370
V91630	232	393
V91630	326	565
V91630	327	566
V91633	10	21
V91636	55	105
V91636	229	386
V91636	230	389
V91636	231	390
V91636	231	391
V91636	247	427
V91636	248	430
V91636	249	433
V91636	250	434
V91636	251	435
V91636	252	437
V91636	253	438
V91636	255	441
V91636	258	447
V91636	262	453
V91636	263	454

		<b>9</b>
V91636	264	455
V91636	265	456
V91636	266	457
V91636	267	458
V91636	267	459
V91636	270	464
V91638	236	400
V91638	238	403
V91638	240	406
V91638	241	409
V91638	242	411
V91638	254	439
V91638	271	465
V91638	272	466
V91638	272	467
V91638	277	475
V91638	278	476
V91652	50	94
V91652	51	95
V91652	52	96
V91653	50	94
V91653	51	95
V91653	52	96
V91655	56	106
V91658	182	310
V91659	182	310
V91667	421	740
V91667	421	741
V91676	421	739
V91676	421	741
V91677	420	738
V91677	421	739
V91678	420	738
V91678	421	739
V91679	420	738
V91709	420	738
V91709	421	740
V91712	10	21
V91712	54	102
V91712	55	103
V91712	80	164
V91713	60	118
V91713	61	119
V91713	61	120
V91713	62	121
V91713	62	122
V91713	63	123
V91713	64	124
V91713	65	125
V91713	83	170
V91713	83	171
V91713	84	172
V91713	85	173
V91713	85	174
V91713	87	178
V91713	292	506
V91713	292	507
V91713	298	519
V91713	298	520
V91713	300	522

# NUMERICAL PARTS LIST

Nummerische Teilenummernliste • Elenco riferimenti  
Liste des références produits

		<b>9</b>
V91713	301	<b>523</b>
V91713	301	<b>524</b>
V91713	302	<b>525</b>
V91713	302	<b>526</b>
V91713	315	<b>547</b>
V91713	321	<b>558</b>
V91713	322	<b>559</b>
V91713	323	<b>560</b>
V91713	324	<b>561</b>
V91713	325	<b>562</b>
V91714	72	<b>146</b>
V91714	73	<b>148</b>
V91714	74	<b>151</b>
V91714	223	<b>373</b>
V91714	224	<b>374</b>
V91714	224	<b>375</b>
V91714	225	<b>376</b>
V91714	226	<b>378</b>
V91714	229	<b>385</b>
V91714	233	<b>395</b>
V91714	233	<b>396</b>
V91714	247	<b>429</b>
V91714	257	<b>445</b>
V91739	10	<b>21</b>
V91739	46	<b>83</b>
V91739	54	<b>102</b>
V91739	80	<b>164</b>
V91762	303	<b>527</b>
V91762	303	<b>528</b>
V91762	304	<b>529</b>
V91762	305	<b>530</b>
V91762	305	<b>531</b>
V91762	306	<b>532</b>
V91762	307	<b>533</b>
V91762	308	<b>534</b>
V91762	309	<b>535</b>
V91762	309	<b>536</b>
V91762	310	<b>538</b>
V91762	311	<b>539</b>
V91762	312	<b>541</b>
V91762	312	<b>542</b>
V91762	313	<b>543</b>
V91762	314	<b>546</b>
V91763	50	<b>94</b>
V91763	51	<b>95</b>
V91763	52	<b>96</b>
V91764	50	<b>94</b>
V91764	51	<b>95</b>
V91764	52	<b>96</b>
V91765	55	<b>104</b>
V91765	55	<b>105</b>
V91765	224	<b>374</b>
V91765	227	<b>380</b>
V91765	227	<b>381</b>
V91765	229	<b>386</b>
V91765	230	<b>389</b>
V91765	231	<b>390</b>
V91765	231	<b>391</b>
V91765	234	<b>398</b>
V91765	235	<b>399</b>

		<b>9</b>
V91765	247	<b>427</b>
V91765	248	<b>430</b>
V91765	249	<b>433</b>
V91765	250	<b>434</b>
V91765	251	<b>435</b>
V91765	252	<b>437</b>
V91765	253	<b>438</b>
V91765	255	<b>441</b>
V91765	258	<b>447</b>
V91765	262	<b>453</b>
V91765	263	<b>454</b>
V91765	264	<b>455</b>
V91765	265	<b>456</b>
V91765	266	<b>457</b>
V91765	267	<b>458</b>
V91765	267	<b>459</b>
V91765	270	<b>464</b>
V91766	6	<b>11</b>
V91766	7	<b>13</b>
V91766	9	<b>20</b>
V91767	173	<b>296</b>
V91767	174	<b>299</b>
V91767	175	<b>300</b>
V91767	176	<b>301</b>
V91767	177	<b>302</b>
V91767	178	<b>303</b>
V91767	179	<b>304</b>
V91767	179	<b>305</b>
V91767	180	<b>306</b>
V91767	181	<b>307</b>
V91767	185	<b>313</b>
V91767	189	<b>318</b>
V91767	190	<b>319</b>
V91767	191	<b>320</b>
V91927	90	<b>184</b>
V91927	91	<b>185</b>
V91927	91	<b>186</b>
V91928	90	<b>184</b>
V91928	91	<b>185</b>
V91928	91	<b>186</b>
V91929	18	<b>38</b>
V91929	19	<b>39</b>
V91929	21	<b>41</b>
V91929	25	<b>48</b>
V91929	26	<b>49</b>
V91929	30	<b>56</b>
V91929	32	<b>58</b>
V91929	33	<b>59</b>
V91929	37	<b>63</b>
V91931	92	<b>187</b>
V91931	95	<b>191</b>
V91931	146	<b>258</b>
V91931	147	<b>259</b>
V91931	148	<b>260</b>
V91931	153	<b>266</b>
V91932	92	<b>187</b>
V91932	95	<b>191</b>
V91932	146	<b>258</b>
V91932	147	<b>259</b>
V91932	148	<b>260</b>

		<b>9</b>
V91932	153	<b>266</b>
V91933	93	<b>189</b>
V91933	94	<b>190</b>
V91933	95	<b>192</b>
V91933	96	<b>193</b>
V91933	97	<b>194</b>
V91933	98	<b>195</b>
V91933	99	<b>196</b>
V91933	100	<b>197</b>
V91933	101	<b>198</b>
V91933	102	<b>199</b>
V91933	103	<b>200</b>
V91933	104	<b>201</b>
V91933	105	<b>203</b>
V91933	106	<b>204</b>
V91933	107	<b>205</b>
V91933	108	<b>206</b>
V91933	149	<b>261</b>
V91933	150	<b>262</b>
V91933	151	<b>263</b>
V91933	151	<b>264</b>
V91933	152	<b>265</b>
V91933	154	<b>267</b>
V91933	155	<b>268</b>
V91933	206	<b>343</b>
V91933	206	<b>344</b>
V91933	207	<b>345</b>
V91933	208	<b>346</b>
V91933	209	<b>348</b>
V91933	210	<b>349</b>
V91933	211	<b>350</b>
V91933	212	<b>351</b>
V91933	213	<b>354</b>
V91933	214	<b>355</b>
V91933	215	<b>356</b>
V91933	216	<b>357</b>
V91934	93	<b>189</b>
V91934	94	<b>190</b>
V91934	95	<b>192</b>
V91934	96	<b>193</b>
V91934	97	<b>194</b>
V91934	98	<b>195</b>
V91934	99	<b>196</b>
V91934	100	<b>197</b>
V91934	101	<b>198</b>
V91934	102	<b>199</b>
V91934	103	<b>200</b>
V91934	104	<b>201</b>
V91934	105	<b>203</b>
V91934	106	<b>204</b>
V91934	107	<b>205</b>
V91934	108	<b>206</b>
V91934	149	<b>261</b>
V91934	150	<b>262</b>
V91934	151	<b>263</b>
V91934	151	<b>264</b>
V91934	152	<b>265</b>
V91934	154	<b>267</b>
V91934	155	<b>268</b>
V91934	206	<b>343</b>

		<b>9</b>
V91934	206	<b>344</b>
V91934	207	<b>345</b>
V91934	208	<b>346</b>
V91934	209	<b>348</b>
V91934	210	<b>349</b>
V91934	211	<b>350</b>
V91934	212	<b>351</b>
V91934	213	<b>354</b>
V91934	214	<b>355</b>
V91934	215	<b>356</b>
V91934	216	<b>357</b>
V91935	236	<b>400</b>
V91935	254	<b>439</b>
V91935	256	<b>443</b>
V91935	256	<b>444</b>
V91935	260	<b>451</b>
V91935	261	<b>452</b>
V91935	268	<b>460</b>
V91935	268	<b>461</b>
V91935	271	<b>465</b>
V91935	272	<b>466</b>
V91935	272	<b>467</b>
V91935	276	<b>474</b>
V91935	277	<b>475</b>
V91935	278	<b>476</b>
V91935	279	<b>478</b>
V91935	281	<b>482</b>
V91936	256	<b>443</b>
V91936	256	<b>444</b>
V91936	260	<b>451</b>
V91936	261	<b>452</b>
V91936	268	<b>460</b>
V91936	268	<b>461</b>
V91936	276	<b>474</b>
V91936	279	<b>478</b>
V91936	281	<b>482</b>
V91937	109	<b>208</b>
V91937	110	<b>209</b>
V91937	156	<b>269</b>
V91937	158	<b>271</b>
V91938	109	<b>208</b>
V91938	110	<b>209</b>
V91938	156	<b>269</b>
V91938	158	<b>271</b>
V91939	365	<b>639</b>
V91939	371	<b>648</b>
V91939	371	<b>649</b>
V91939	376	<b>657</b>
V91939	377	<b>659</b>
V91939	379	<b>662</b>
V91939	380	<b>663</b>
V91939	389	<b>677</b>
V91939	410	<b>718</b>
V91939	411	<b>719</b>
V91939	411	<b>720</b>
V91939	412	<b>721</b>
V91939	413	<b>723</b>
V91939	417	<b>733</b>
V91939	418	<b>734</b>
V91939	418	<b>735</b>

		 <b>9</b>	
V91939	420	737	
V91940	365	639	
V91940	371	648	
V91940	371	649	
V91940	376	657	
V91940	377	659	
V91940	379	662	
V91940	380	663	
V91940	389	677	
V91940	410	718	
V91940	411	719	
V91940	411	720	
V91940	412	721	
V91940	413	723	
V91940	417	733	
V91940	418	734	
V91940	418	735	
V91940	420	737	
V91949	88	180	
V91949	89	181	
V91949	315	548	
V91949	317	551	
V91949	317	552	
V91949	318	553	
V91949	319	555	
V91949	319	556	
V91949	320	557	
V91950	88	180	
V91950	89	181	
V91950	315	548	
V91950	317	551	
V91950	317	552	
V91950	318	553	
V91950	319	555	
V91950	319	556	
V91950	320	557	
V91970	293	509	
V91970	294	510	
V91970	295	513	
V91970	330	574	
V91970	330	575	
V91971	296	514	
V91972	293	509	
V91972	294	510	
V91972	295	513	
V91972	296	514	
V91972	330	574	
V91972	330	575	
V91994	365	639	
V91994	371	648	
V91994	371	649	
V91994	376	657	
V91994	377	659	
V91994	405	710	
V91994	406	711	
V91994	407	712	
V91994	408	713	
V91994	409	715	
V91994	409	716	
V91994	410	717	

		 <b>9</b>	
V91994	413	724	
V91994	414	725	
V91994	414	726	
V91994	415	727	
V91994	416	731	
V91994	417	732	
V91994	418	734	
V91994	418	735	
V91994	419	736	
V91994	420	737	
V94017	200	331	
V94017	203	336	
V94024	201	333	
V94024	202	334	
V94024	204	339	
V94029	28	51	
V94029	28	52	
V94029	29	53	
V94029	31	57	
V94029	34	60	
V94029	35	61	
V94029	39	66	
V94029	44	77	
V94030	28	51	
V94030	28	52	
V94030	29	53	
V94030	31	57	
V94030	34	60	
V94030	35	61	
V94030	39	66	
V94030	44	77	
V94064	111	210	
V94064	112	211	
V94064	114	213	
V94064	116	216	
V94064	117	217	
V94064	118	218	
V94064	122	222	
V94064	127	230	
V94064	130	235	
V94064	131	236	
V94064	141	253	
V94064	142	254	
V94064	143	255	
V94064	157	270	
V94064	159	272	
V94064	160	273	
V94064	161	274	
V94064	162	275	
V94064	163	276	
V94064	164	277	
V94064	169	289	
V94064	170	290	
V94064	171	291	
V94064	172	294	
V94064	201	333	
V94064	202	334	
V94064	204	339	
V94065	111	210	
V94065	112	211	
V94065	114	213	
V94065	116	216	
V94065	117	217	
V94065	118	218	
V94065	122	222	
V94065	127	230	
V94065	130	235	
V94065	131	236	
V94065	141	253	
V94065	142	254	
V94065	143	255	
V94065	157	270	
V94065	159	272	
V94065	160	273	
V94065	161	274	
V94065	162	275	
V94065	163	276	
V94065	164	277	
V94065	169	289	
V94065	170	290	
V94065	171	291	
V94065	172	294	
V94065	201	333	
V94065	202	334	
V94065	204	339	
V94065	288	499	
V94065	289	500	
V94065	289	500	
V94065	295	512	
V94065	295	512	
V94065	285	494	
V94065	287	497	
V94065	285	494	
V94065	287	497	
V94065	329	570	
V94065	329	570	
V94065	282	485	
V94065	282	486	
V94065	282	485	
V94065	282	486	
V94065	338	597	
V94065	339	598	
V94065	339	599	
V94065	338	597	
V94065	339	598	
V94065	339	599	
V94065	18	38	
V94065	19	39	
V94065	284	490	
V94065	286	495	
V94065	286	496	
V94065	88	180	
V94065	89	181	
V94065	315	548	
V94065	317	551	
V94065	317	552	
V94065	318	553	
V94065	319	555	
V94065	319	556	
V94065	320	557	
V94065	319	555	
V94065	319	556	
V94065	320	557	
V94065	118	218	

		 <b>9</b>	
V94065	122	222	
V94065	127	230	
V94065	130	235	
V94065	131	236	
V94065	132	237	
V94065	136	246	
V94065	141	253	
V94065	142	254	
V94065	143	255	
V94065	157	270	
V94065	159	272	
V94065	160	273	
V94065	161	274	
V94065	162	275	
V94065	163	276	
V94065	164	277	
V94065	169	289	
V94065	170	290	
V94065	171	291	
V94154	171	292	
V94154	172	294	
V94154	201	333	
V94154	202	334	
V94154	204	339	
V94169	288	499	
V94169	289	500	
V94170	288	499	
V94170	289	500	
V94175	295	512	
V94176	295	512	
V94178	285	494	
V94178	287	497	
V94179	285	494	
V94179	287	497	
V94198	329	570	
V94199	329	570	
V94200	282	485	
V94200	282	486	
V94201	282	485	
V94201	282	486	
V94210	338	597	
V94210	339	598	
V94210	339	599	
V94211	338	597	
V94211	339	598	
V94211	339	599	
V94216	18	38	
V94216	19	39	
V94438	284	490	
V94438	286	495	
V94438	286	496	
V94468	88	180	
V94468	89	181	
V94468	315	548	
V94468	317	551	
V94468	317	552	
V94468	318	553	
V94468	319	555	
V94468	319	556	
V94468	320	557	

		 <b>9</b>	
V94470	111	210	
V94470	112	211	
V94470	113	212	
V94470	114	213	
V94470	115	214	
V94470	116	216	
V94470	117	217	
V94470	118	218	
V94470	120	220	
V94470	121	221	
V94470	122	222	
V94470	124	225	
V94470	125	226	
V94470	127	230	
V94470	130	235	
V94470	131	236	
V94470	132	237	
V94470	135	244	
V94470	136	246	
V94470	141	253	
V94470	142	254	
V94470	143	255	
V94470	144	256	
V94470	145	257	
V94470	157	270	
V94470	159	272	
V94470	160	273	
V94470	161	274	
V94470	162	275	
V94470	163	276	
V94470	164	277	
V94470	169	289	
V94470	170	290	
V94470	171	291	
V94471	111	210	
V94471	112	211	
V94471	113	212	
V94471	114	213	
V94471	115	214	
V94471	116	216	
V94471	117	217	
V94471	118	218	
V94471	120	220	
V94471	121	221	
V94471	122	222	
V94471	124	225	
V94471	125	226	
V94471	127	230	
V94471	130	235	
V94471	131	236	
V94471	132	237	
V94471	135	244	
V94471	136	246	
V94471	141	253	
V94471	142	254	
V94471	143	255	
V94471	144	256	
V94471	145	257	
V94471	157	270	
V94471	159	272	

# NUMERICAL PARTS LIST

Numerische Teilenummernliste • Elenco riferimenti  
Liste des références produits

 <b>9</b>		
V94471	160	273
V94471	161	274
V94471	162	275
V94471	163	276
V94471	164	277
V94471	169	289
V94471	170	290
V94471	171	291
V94486	284	490
V94486	286	495
V94486	286	496
V94487	284	490
V94487	286	495
V94487	286	496
V94490	291	505
V94491	291	505
V94576	4	5
V94576	4	6
V94576	7	13
V94576	7	14
V94576	8	15
V94582	97	194
V94582	98	195
V94582	99	196
V94582	100	197
V94582	101	198
V94582	102	199
V94582	103	200
V94582	104	201
V94582	103	200
V94582	104	201
V94582	213	354
V94582	214	355
V94582	215	356
V94582	216	357
V94588	123	223
V94588	124	224
V94588	133	240
V94588	134	241
V94588	137	247
V94588	138	248
V94588	139	249
V94588	167	286
V94588	168	287
V94589	123	223
V94589	124	224
V94589	133	240
V94589	134	241
V94589	137	247
V94589	138	248
V94589	139	249
V94589	167	286
V94589	168	287
V94590	111	210
V94590	112	211
V94590	113	212
V94590	114	213
V94590	116	216
V94590	117	217
V94590	118	218
V94590	122	222
V94590	127	230

 <b>9</b>		
V94590	130	235
V94590	131	236
V94590	142	254
V94590	143	255
V94590	144	256
V94590	157	270
V94590	159	272
V94590	160	273
V94590	161	274
V94590	162	275
V94590	163	276
V94590	164	277
V94590	169	289
V94590	170	290
V94590	171	291
V94591	93	189
V94591	94	190
V94591	95	192
V94591	96	193
V94591	97	194
V94591	98	195
V94591	99	196
V94591	100	197
V94591	101	198
V94591	102	199
V94591	103	200
V94591	104	201
V94591	105	203
V94591	106	204
V94591	107	205
V94591	108	206
V94591	206	343
V94591	206	344
V94591	207	345
V94591	208	346
V94591	209	348
V94591	210	349
V94591	211	350
V94591	212	351
V94591	213	354
V94591	214	355
V94591	215	356
V94591	216	357
V94592	332	580
V94592	333	582
V94592	334	583
V94592	334	584
V94592	336	588
V94593	332	580
V94593	333	582
V94593	334	583
V94593	334	584
V94593	336	588
V94593	336	590
V94732	246	423
V94793	80	165
V94795	80	165
V94962	293	508
V94962	297	517
V94962	297	518

 <b>9</b>		
V94963	293	508
V94963	297	517
V94963	297	518
V95007	58	111
V95008	58	111
V95015	10	22
V95015	12	26
V95015	13	28
V95016	10	22
V95016	12	26
V95016	13	28
V95083	290	502
V95083	290	503
V95084	290	502
V95084	290	503
V98001	329	573
V98002	329	573
V98003	293	508
V98003	297	518
V98004	293	508
V98004	297	518
V98005	123	223
V98005	133	240
V98005	134	241
V98005	137	247
V98005	138	248
V98005	139	249
V98005	167	286
V98005	168	287
V98006	123	223
V98006	133	240
V98006	134	241
V98006	137	247
V98006	138	248
V98006	139	249
V98006	167	286
V98006	168	287
V98018	332	580
V98018	333	582
V98018	334	583
V98018	334	584
V98018	336	588
V98019	332	580
V98019	333	582
V98019	334	583
V98019	334	584
V98019	336	588
V98020	20	40
V98020	32	58
V98020	33	59
V98020	37	63
V98021	20	40
V98021	32	58
V98021	33	59
V98021	37	63
V98022	23	45
V98022	36	62
V98022	43	76
V98023	23	45
V98023	36	62

 <b>9</b>		
V98023	43	76
V98024	89	182
V98025	89	182
V98026	34	60
V98026	35	61
V98026	39	66
V98026	41	70
V98026	42	73
V98026	42	75
V98026	44	77
V98026	44	78
V98026	45	80
V98027	34	60
V98027	35	61
V98027	39	66
V98027	42	73
V98027	44	77
V98028	297	516
V98029	297	516
V98042	421	742
V98042	422	743
V98042	423	746
V98043	421	742
V98043	422	743
V98043	423	746
VAG586	59	115
VAG701	59	115
VAG50895	6	11
VAG50895	7	13
VAG50895	7	14
VAG50895	8	15
VAG50895	9	20
VAG50895	15	35
VAG50895	16	36
VAG50895	17	37
VAG50895	18	38
VAG50895	19	39
VAG50895	20	40
VAG50895	22	43
VAG50895	24	47
VAG50895	25	48
VAG50895	26	49
VAG50895	27	50
VAG50895	30	56
VAG50895	38	64
VAG50895	88	180
VAG50895	89	181
VAG50895	105	203
VAG50895	106	204
VAG50895	107	205
VAG50895	108	206
VAG51007	331	576
VAG51023B	72	145
VAG51023B	72	146
VAG51023B	73	148
VAG51023B	74	151
VAG51023B	223	373
VAG51023B	225	376
VAG51023B	226	378
VAG51023B	229	385

			<b>9</b>
VAG51023B	233	395	
VAG51023B	233	396	
VAG51023B	257	445	
VAG92168B	56	107	
VAG92168B	57	108	
VAG92168B	57	109	
VAG92168B	57	110	
VAG92168B	58	112	
VAG92168B	71	142	
VAG92168B	74	152	
VAG92168B	75	154	
VAG92168B	75	155	
VAG92168B	76	157	
VAG92168B	245	420	
VAG92168B	246	423	
VAG92193	331	577	
VAG92193	345	612	
VAG92193	346	613	
VAG92193	347	614	
VAG92193	348	615	
VAG92193	348	616	
VAG92193	349	617	
VAG92193	350	618	
VAG92193	351	619	
VAG92193	352	620	
VAG92193	353	621	
VAG92193	354	623	
VAG92193	355	624	
VAG92193	356	625	
VAG92193	357	626	
VAG92193	357	627	
VAG92193	358	628	
VAG92193	358	629	
VAG92193	359	630	
VAG92193	359	631	
VAG92193	360	632	
VAG92193	361	633	
VAG92193	362	634	
VAG92193	363	635	
VAG92193	363	636	
VAG92193	364	637	
VAG92193	364	638	
VAG92193	365	639	
VAG92193	366	640	
VAG92193	367	641	
VAG92193	368	642	
VAG92193	368	643	
VAG92193	369	645	
VAG92193	370	646	
VAG92193	371	648	
VAG92193	371	649	
VAG92193	372	650	
VAG92193	372	651	
VAG92193	373	652	
VAG92193	374	653	
VAG92193	374	654	
VAG92193	375	655	
VAG92193	375	656	
VAG92193	376	657	
VAG92193	376	658	

			<b>9</b>
VAG92193	377	659	
VAG92193	378	660	
VAG92193	379	661	
VAG92193	379	662	
VAG92193	380	663	
VAG92193	380	664	
VAG92193	381	665	
VAG92193	381	666	
VAG92193	382	667	
VAG92193	383	668	
VAG92193	384	671	
VAG92193	385	672	
VAG92193	385	673	
VAG92193	386	674	
VAG92193	387	675	
VAG92193	388	676	
VAG92193	389	677	
VAG92193	390	679	
VAG92193	391	680	
VAG92193	392	681	
VAG92193	393	682	
VAG92193	394	683	
VAG92193	419	736	
VAG92193	420	737	
VAG92194	331	577	
VAG92194	345	612	
VAG92194	346	613	
VAG92194	347	614	
VAG92194	348	615	
VAG92194	348	616	
VAG92194	349	617	
VAG92194	350	618	
VAG92194	351	619	
VAG92194	352	620	
VAG92194	353	621	
VAG92194	354	623	
VAG92194	355	624	
VAG92194	356	625	
VAG92194	357	626	
VAG92194	357	627	
VAG92194	358	628	
VAG92194	358	629	
VAG92194	359	630	
VAG92194	359	631	
VAG92194	360	632	
VAG92194	362	634	
VAG92194	365	639	
VAG92194	366	640	
VAG92194	367	641	
VAG92194	368	642	
VAG92194	368	643	
VAG92194	369	645	
VAG92194	369	645	
VAG92194	370	646	
VAG92194	371	648	
VAG92194	371	649	
VAG92194	372	650	
VAG92194	372	651	
VAG92194	373	652	
VAG92194	374	653	

			<b>9</b>
VAG92194	374	654	
VAG92194	375	655	
VAG92194	375	656	
VAG92194	376	657	
VAG92194	376	658	
VAG92194	377	659	
VAG92194	378	660	
VAG92194	379	661	
VAG92194	379	662	
VAG92194	380	663	
VAG92194	380	664	
VAG92194	381	665	
VAG92194	381	666	
VAG92194	382	667	
VAG92194	383	668	
VAG92194	385	672	
VAG92194	385	673	
VAG92194	386	674	
VAG92194	387	675	
VAG92194	388	676	
VAG92194	389	677	
VAG92194	390	679	
VAG92194	391	680	
VAG92194	392	681	
VAG92194	393	682	
VAG92194	394	683	
VAG92194	419	736	
VAG92194	420	737	
VAG92288B	200	331	
VAG92288B	201	333	
VAG92288B	202	334	
VAG92288B	203	336	
VAG92288B	204	339	
VAG92331B	201	333	
VAG92331B	202	334	
VAG92331B	204	339	
VAG92332B	199	330	
VAG92364	2	1	
VAG92364	2	2	
VAG92364	3	3	
VAG92364	4	5	
VAG92364	4	6	
VAG92364	5	8	
VAG92364	5	9	
VAG92364	6	10	
VAG92364	6	11	
VAG92364	7	13	
VAG92364	7	14	
VAG92364	8	15	
VAG92364	8	16	
VAG92364	9	17	
VAG92364	9	20	
VAG92364	15	35	
VAG92364	16	36	
VAG92364	17	37	
VAG92364	18	38	
VAG92364	19	39	
VAG92364	20	40	
VAG92364	22	43	
VAG92364	24	47	

			<b>9</b>
VAG92364	25	48	
VAG92364	26	49	
VAG92364	27	50	
VAG92364	30	56	
VAG92364	32	58	
VAG92364	33	59	
VAG92364	37	63	
VAG92364	38	64	
VAG92364	88	180	
VAG92364	89	181	
VAG92364	315	548	
VAG92364	317	551	
VAG92364	317	552	
VAG92364	318	553	
VAG92364	319	555	
VAG92364	319	556	
VAG92364	320	557	
VAG92366	62	121	
VAG92366	62	122	
VAG92366	63	123	
VAG92366	65	125	
VAG92366	83	170	
VAG92366	83	171	
VAG92366	84	172	
VAG92366	85	173	
VAG92366	85	174	
VAG92366	87	178	
VAG92366	173	296	
VAG92366	174	299	
VAG92366	175	300	
VAG92366	176	301	
VAG92366	177	302	
VAG92366	178	303	
VAG92366	179	304	
VAG92366	179	305	
VAG92366	180	306	
VAG92366	181	307	
VAG92366	182	310	
VAG92366	183	311	
VAG92366	184	312	
VAG92366	185	313	
VAG92366	186	314	
VAG92366	187	315	
VAG92366	188	316	
VAG92366	188	317	
VAG92366	189	318	
VAG92366	190	319	
VAG92366	191	320	
VAG92366	192	321	
VAG92366	193	322	
VAG92366	194	323	
VAG92366	195	324	
VAG92366	292	506	
VAG92366	292	507	
VAG92366	298	519	
VAG92366	298	520	
VAG92366	300	522	
VAG92366	301	523	
VAG92366	301	524	
VAG92366	302	525	

# NUMERICAL PARTS LIST

Nummerische Teilenummernliste • Elenco riferimenti  
 Liste des références produits

 <b>9</b>		
VAG92366	302	526
VAG92366	303	527
VAG92366	303	528
VAG92366	304	529
VAG92366	305	530
VAG92366	305	531
VAG92366	306	532
VAG92366	307	533
VAG92366	308	534
VAG92366	309	535
VAG92366	309	536
VAG92366	310	538
VAG92366	311	539
VAG92366	312	541
VAG92366	312	542
VAG92366	313	543
VAG92366	314	546
VAG92366	315	547
VAG92366	321	558
VAG92366	322	559
VAG92366	323	560
VAG92366	324	561
VAG92366	325	562
VAG92369	49	93
VAG92369	54	101
VAG92369	345	612
VAG92369	346	613
VAG92369	347	614
VAG92369	348	615
VAG92369	348	616
VAG92369	349	617
VAG92369	350	618
VAG92369	351	619
VAG92369	352	620
VAG92369	353	621
VAG92369	354	622
VAG92369	355	624
VAG92369	356	625
VAG92369	357	626
VAG92369	357	627
VAG92369	358	628
VAG92369	358	629
VAG92369	359	630
VAG92369	359	631
VAG92369	360	632
VAG92369	361	633
VAG92369	362	634
VAG92369	363	635
VAG92369	363	636
VAG92369	364	637
VAG92369	364	638
VAG92369	365	639
VAG92369	366	640
VAG92369	367	641
VAG92369	368	642
VAG92369	368	643
VAG92369	369	644
VAG92369	369	645
VAG92369	370	646
VAG92369	370	647

 <b>9</b>		
VAG92369	371	648
VAG92369	371	649
VAG92369	372	650
VAG92369	372	651
VAG92369	373	652
VAG92369	374	653
VAG92369	374	654
VAG92369	375	655
VAG92369	375	656
VAG92369	376	657
VAG92369	376	658
VAG92369	377	659
VAG92369	378	660
VAG92369	379	661
VAG92369	379	662
VAG92369	380	663
VAG92369	380	664
VAG92369	381	665
VAG92369	381	666
VAG92369	382	667
VAG92369	383	668
VAG92369	384	671
VAG92369	385	672
VAG92369	385	673
VAG92369	386	674
VAG92369	387	675
VAG92369	388	676
VAG92369	389	677
VAG92369	390	679
VAG92369	391	680
VAG92369	392	681
VAG92369	393	682
VAG92369	394	683
VAG92369	405	710
VAG92369	406	711
VAG92369	407	712
VAG92369	408	713
VAG92369	409	715
VAG92369	409	716
VAG92369	410	717
VAG92369	410	718
VAG92369	411	719
VAG92369	411	720
VAG92369	412	721
VAG92369	413	723
VAG92369	413	724
VAG92369	414	725
VAG92369	414	726
VAG92369	416	731
VAG92369	417	732
VAG92369	417	733
VAG92369	418	734
VAG92369	418	735
VAG92369	419	736
VAG92369	420	737
VAG92369	420	737
VAG92373	345	612
VAG92373	346	613
VAG92373	347	614
VAG92373	348	615

 <b>9</b>		
VAG92373	348	616
VAG92373	349	617
VAG92373	350	618
VAG92373	351	619
VAG92373	352	620
VAG92373	353	621
VAG92373	354	622
VAG92373	355	624
VAG92373	356	625
VAG92373	357	626
VAG92373	357	627
VAG92373	358	628
VAG92373	358	629
VAG92373	359	630
VAG92373	359	631
VAG92373	360	632
VAG92373	361	633
VAG92373	362	634
VAG92373	363	635
VAG92373	363	636
VAG92373	364	637
VAG92373	364	638
VAG92373	365	639
VAG92373	366	640
VAG92373	367	641
VAG92373	368	642
VAG92373	368	643
VAG92373	369	644
VAG92373	369	645
VAG92373	370	646
VAG92373	370	647
VAG92373	371	648
VAG92373	371	649
VAG92373	372	650
VAG92373	372	651
VAG92373	373	652
VAG92373	374	653
VAG92373	374	654
VAG92373	375	655
VAG92373	375	656
VAG92373	376	657
VAG92373	376	658
VAG92373	377	659
VAG92373	378	660
VAG92373	379	661
VAG92373	379	662
VAG92373	380	663
VAG92373	380	664
VAG92373	381	665
VAG92373	381	666
VAG92373	382	667
VAG92373	383	668
VAG92373	384	671
VAG92373	385	672
VAG92373	385	673
VAG92373	386	674
VAG92373	387	675
VAG92373	388	676
VAG92373	389	677
VAG92373	390	679

 <b>9</b>		
VAG92373	391	680
VAG92373	392	681
VAG92373	393	682
VAG92373	394	683
VAG92373	405	710
VAG92373	406	711
VAG92373	407	712
VAG92373	408	713
VAG92373	409	715
VAG92373	409	716
VAG92373	410	717
VAG92373	410	718
VAG92373	411	719
VAG92373	411	720
VAG92373	412	721
VAG92373	413	723
VAG92373	413	724
VAG92373	414	725
VAG92373	414	726
VAG92373	415	727
VAG92373	416	731
VAG92373	417	732
VAG92373	417	733
VAG92373	418	734
VAG92373	418	735
VAG92373	419	736
VAG92373	420	737
VAG92401	46	85
VAG92444	345	612
VAG92444	346	613
VAG92444	347	614
VAG92444	348	615
VAG92444	348	616
VAG92444	349	617
VAG92444	350	618
VAG92444	351	619
VAG92444	352	620
VAG92444	353	621
VAG92444	354	622
VAG92444	354	623
VAG92444	355	624
VAG92444	356	625
VAG92444	357	626
VAG92444	357	627
VAG92444	358	628
VAG92444	358	629
VAG92444	359	630
VAG92444	359	631
VAG92444	360	632
VAG92444	361	633
VAG92444	362	634
VAG92444	365	639
VAG92444	366	640
VAG92444	367	641
VAG92444	368	642
VAG92444	368	643
VAG92444	369	644
VAG92444	369	645
VAG92444	370	646
VAG92444	370	647



		9
VAG92444	371	648
VAG92444	371	649
VAG92444	372	650
VAG92444	372	651
VAG92444	373	652
VAG92444	374	653
VAG92444	374	654
VAG92444	375	655
VAG92444	375	656
VAG92444	376	657
VAG92444	376	658
VAG92444	377	659
VAG92444	378	660
VAG92444	379	661
VAG92444	379	662
VAG92444	380	663
VAG92444	380	664
VAG92444	381	665
VAG92444	381	666
VAG92444	382	667
VAG92444	383	668
VAG92444	385	672
VAG92444	385	673
VAG92444	386	674
VAG92444	387	675
VAG92444	388	676
VAG92444	389	677
VAG92444	390	679
VAG92444	391	680
VAG92444	392	681
VAG92444	393	682
VAG92444	394	683
VAG92444	405	710
VAG92444	406	711
VAG92444	407	712
VAG92444	408	713
VAG92444	409	715
VAG92444	409	716
VAG92444	410	717
VAG92444	410	718
VAG92444	411	719
VAG92444	411	720
VAG92444	411	719
VAG92444	411	720
VAG92444	412	721
VAG92444	413	723
VAG92444	413	724
VAG92444	413	723
VAG92444	413	724
VAG92444	414	725
VAG92444	414	726
VAG92444	415	727
VAG92444	416	731
VAG92444	417	732
VAG92444	417	733
VAG92444	417	734
VAG92444	418	735
VAG92444	419	736
VAG92444	420	737
VAG92444	420	738
VAG92444	421	739
VAG92444	421	740
VAG92444	421	741
VAG92444	345	612

		9
VAG92445	346	613
VAG92445	347	614
VAG92445	348	615
VAG92445	348	616
VAG92445	349	617
VAG92445	350	618
VAG92445	351	619
VAG92445	352	620
VAG92445	353	621
VAG92445	354	622
VAG92445	354	623
VAG92445	355	624
VAG92445	356	625
VAG92445	357	626
VAG92445	357	627
VAG92445	358	628
VAG92445	358	629
VAG92445	359	630
VAG92445	359	631
VAG92445	360	632
VAG92445	361	633
VAG92445	362	634
VAG92445	363	635
VAG92445	363	636
VAG92445	364	637
VAG92445	364	638
VAG92445	365	639
VAG92445	366	640
VAG92445	367	641
VAG92445	368	642
VAG92445	368	643
VAG92445	369	644
VAG92445	369	645
VAG92445	370	646
VAG92445	370	647
VAG92445	371	648
VAG92445	371	649
VAG92445	372	650
VAG92445	372	651
VAG92445	373	652
VAG92445	374	653
VAG92445	374	654
VAG92445	375	655
VAG92445	375	656
VAG92445	376	657
VAG92445	376	658
VAG92445	377	659
VAG92445	378	660
VAG92445	379	661
VAG92445	379	662
VAG92445	380	663
VAG92445	380	664
VAG92445	381	665
VAG92445	381	666
VAG92445	382	667
VAG92445	383	668
VAG92445	384	671
VAG92445	385	672
VAG92445	385	673
VAG92445	386	674

		9
VAG92445	387	675
VAG92445	388	676
VAG92445	389	677
VAG92445	390	679
VAG92445	391	680
VAG92445	392	681
VAG92445	393	682
VAG92445	394	683
VAG92445	405	710
VAG92445	406	711
VAG92445	407	712
VAG92445	408	713
VAG92445	409	715
VAG92445	409	716
VAG92445	410	717
VAG92445	410	718
VAG92445	411	719
VAG92445	411	720
VAG92445	412	721
VAG92445	413	723
VAG92445	413	724
VAG92445	414	725
VAG92445	414	726
VAG92445	415	727
VAG92445	416	731
VAG92445	417	732
VAG92445	417	733
VAG92445	418	734
VAG92445	418	735
VAG92445	419	736
VAG92445	420	737
VAG92465B	200	331
VAG92465B	203	336
VAG92496	236	400
VAG92496	254	439
VAG92496	256	443
VAG92496	256	444
VAG92496	260	451
VAG92496	261	452
VAG92496	268	460
VAG92496	268	461
VAG92496	271	465
VAG92496	272	466
VAG92496	272	467
VAG92496	276	474
VAG92496	277	475
VAG92496	278	476
VAG92496	279	478
VAG92496	281	482
VAG92497	421	739
VAG92497	421	740
VAG92497	421	741
VAG96047	293	509
VAG96047	294	510
VAG96047	295	513
VAG96047	296	514
VAG96047	330	574
VAG96047	330	575
VAG96056B	199	330
VAG96100	172	294

		9
VAG96116B	199	330
VAG96119	284	490
VAG96119	285	494
VAG96119	286	495
VAG96119	286	496
VAG96119	287	497
VAG96119	290	502
VAG96119	290	503
VAG96119	291	505
VAG96123	90	184
VAG96123	91	185
VAG96123	97	194
VAG96123	98	195
VAG96123	99	196
VAG96123	100	197
VAG96123	101	198
VAG96123	102	199
VAG96123	103	200
VAG96123	104	201
VAG96123	146	258
VAG96123	147	259
VAG96123	148	260
VAG96123	149	261
VAG96123	150	262
VAG96123	151	263
VAG96123	151	264
VAG96123	152	265
VAG96123	153	266
VAG96123	154	267
VAG96123	155	268
VAG96123	206	343
VAG96123	206	344
VAG96123	207	345
VAG96123	208	346
VAG96123	209	348
VAG96123	210	349
VAG96123	211	350
VAG96123	212	351
VAG96123	213	354
VAG96123	214	355
VAG96123	215	356
VAG96123	216	357
VAG96123	315	548
VAG96123	317	551
VAG96123	317	552
VAG96123	318	553
VAG96123	319	555
VAG96123	319	556
VAG96123	320	557
VAG96124	109	208
VAG96124	110	209
VAG96124	111	210
VAG96124	112	211
VAG96124	113	212
VAG96124	114	213
VAG96124	115	214
VAG96124	116	216
VAG96124	117	217
VAG96124	118	218
VAG96124	120	220

# NUMERICAL PARTS LIST

Numerische Teilenummernliste • Elenco riferimenti  
Liste des références produits

 <b>9</b>		
VAG96124	121	221
VAG96124	122	222
VAG96124	124	225
VAG96124	125	226
VAG96124	127	230
VAG96124	130	235
VAG96124	135	244
VAG96124	142	254
VAG96124	143	255
VAG96124	145	257
VAG96124	156	269
VAG96124	157	270
VAG96124	158	271
VAG96124	159	272
VAG96124	160	273
VAG96124	162	275
VAG96124	163	276
VAG96132	46	85
VAG96145	97	194
VAG96145	98	195
VAG96145	99	196
VAG96145	100	197
VAG96145	101	198
VAG96145	102	199
VAG96145	103	200
VAG96145	104	201
VAG96145	146	258
VAG96145	147	259
VAG96145	148	260
VAG96145	149	261
VAG96145	150	262
VAG96145	151	263
VAG96145	152	264
VAG96145	153	265
VAG96145	154	266
VAG96145	155	268
VAG96145	213	354
VAG96145	214	355
VAG96145	215	356
VAG96145	216	357
VAG96145	315	548
VAG96145	317	551
VAG96145	318	553
VAG96145	319	555
VAG96145	319	556
VAG96145	320	557
VAG96145	VAG96160B	201 333
VAG96145	VAG96160B	202 334
VAG96145	VAG96160B	204 339
VAG96145	VAG96171	223 373
VAG96145	VAG96171	224 374
VAG96145	VAG96171	224 375
VAG96145	VAG96171	225 376
VAG96145	VAG96171	226 378
VAG96145	VAG96171	227 380
VAG96145	VAG96171	227 381
VAG96145	VAG96171	229 385
VAG96145	VAG96171	229 386
VAG96145	VAG96171	230 389
VAG96145	VAG96171	231 390
VAG96145	VAG96171	231 391
VAG96145	VAG96171	233 395
VAG96145	VAG96171	233 396
VAG96145	VAG96171	234 398
VAG96146	90	184
VAG96146	91	185
VAG96146	91	186
VAG96146	93	189
VAG96146	94	190
VAG96146	95	191
VAG96146	95	192
VAG96146	96	193
VAG96146	97	194
VAG96146	98	195
VAG96146	99	196
VAG96146	100	197
VAG96146	101	198
VAG96146	102	199
VAG96146	103	200
VAG96146	104	201
VAG96146	105	203
VAG96146	106	204
VAG96146	107	205

 <b>9</b>		
VAG96146	108	206
VAG96146	146	258
VAG96146	147	259
VAG96146	148	260
VAG96146	149	261
VAG96146	150	262
VAG96146	151	263
VAG96146	151	264
VAG96146	152	265
VAG96146	153	266
VAG96146	154	267
VAG96146	155	268
VAG96146	213	354
VAG96146	214	355
VAG96146	215	356
VAG96146	216	357
VAG96146	315	548
VAG96146	317	551
VAG96146	317	552
VAG96146	318	553
VAG96146	319	555
VAG96146	319	556
VAG96146	320	557
VAG96146	VAG96160B	201 333
VAG96146	VAG96160B	202 334
VAG96146	VAG96160B	204 339
VAG96146	VAG96171	223 373
VAG96146	VAG96171	224 374
VAG96146	VAG96171	224 375
VAG96146	VAG96171	225 376
VAG96146	VAG96171	226 378
VAG96146	VAG96171	227 380
VAG96146	VAG96171	227 381
VAG96146	VAG96171	229 385
VAG96146	VAG96171	229 386
VAG96146	VAG96171	230 389
VAG96146	VAG96171	231 390
VAG96146	VAG96171	231 391
VAG96146	VAG96171	233 395
VAG96146	VAG96171	233 396
VAG96146	VAG96171	234 398
VAG96146	VAG96171	235 399
VAG96146	VAG96171	236 401
VAG96146	VAG96171	237 402
VAG96146	VAG96171	238 403
VAG96146	VAG96171	239 404
VAG96146	VAG96171	239 405
VAG96146	VAG96171	240 406
VAG96146	VAG96171	241 408
VAG96146	VAG96171	241 409
VAG96146	VAG96171	242 410
VAG96146	VAG96171	242 411
VAG96146	VAG96171	247 427
VAG96146	VAG96171	247 429
VAG96146	VAG96171	248 430
VAG96146	VAG96171	249 433
VAG96146	VAG96171	250 434
VAG96146	VAG96171	251 435
VAG96146	VAG96171	252 437
VAG96146	VAG96171	253 438

 <b>9</b>		
VAG96171	255	441
VAG96171	257	445
VAG96171	258	447
VAG96171	259	448
VAG96171	259	449
VAG96171	260	450
VAG96171	262	453
VAG96171	263	454
VAG96171	264	455
VAG96171	265	456
VAG96171	266	457
VAG96171	267	458
VAG96171	267	459
VAG96171	269	462
VAG96171	269	463
VAG96171	270	464
VAG96171	274	470
VAG96171	274	471
VAG96171	280	480
VAG96181B	254	439
VAG96181B	256	443
VAG96181B	256	444
VAG96181B	260	451
VAG96181B	261	452
VAG96181B	268	460
VAG96181B	268	461
VAG96181B	271	465
VAG96181B	272	466
VAG96181B	272	467
VAG96181B	273	468
VAG96181B	276	474
VAG96181B	277	475
VAG96181B	278	476
VAG96181B	279	478
VAG96184	338	597
VAG96184	339	598
VAG96184	339	599
VAG96184	396	688
VAG96184	396	689
VAG96184	397	691
VAG96184	398	692
VAG96184	398	693
VAG96184	399	694
VAG96184	400	696
VAG96184	401	698
VAG96184	401	700
VAG96184	402	701
VAG96184	403	703
VAG96187	332	579
VAG96187	341	604
VAG96187	341	605
VAG96187	342	606
VAG96187	342	607
VAG96187	343	608
VAG96187	343	609
VAG96187	344	610
VAG96187	344	611
VAG96188B	328	568
VAG96188B	328	569
VAG96197B	396	688

 <b>9</b>		
VAG96197B	396	689
VAG96197B	397	691
VAG96197B	398	692
VAG96197B	398	693
VAG96197B	400	696
VAG96197B	401	698
VAG96197B	401	700
VAG96197B	402	701
VAG96197B	403	703
VAG96199	236	400
VAG96199	254	439
VAG96199	256	443
VAG96199	256	444
VAG96199	260	451
VAG96199	261	452
VAG96199	268	460
VAG96199	268	461
VAG96199	271	465
VAG96199	272	466
VAG96199	272	467
VAG96199	273	468
VAG96199	276	474
VAG96199	277	475
VAG96199	278	476
VAG96199	279	478
VAG96203	109	208
VAG96203	110	209
VAG96203	111	210
VAG96203	112	211
VAG96203	113	212
VAG96203	114	213
VAG96203	115	214
VAG96203	116	216
VAG96203	117	217
VAG96203	118	218
VAG96203	120	220
VAG96203	121	221
VAG96203	122	222
VAG96203	124	225
VAG96203	125	226
VAG96203	127	230
VAG96203	130	235
VAG96203	131	236
VAG96203	135	244
VAG96203	141	253
VAG96203	142	254
VAG96203	143	255
VAG96203	144	256
VAG96203	145	257
VAG96203	156	269
VAG96203	157	270
VAG96203	158	271
VAG96203	159	272
VAG96203	160	273
VAG96203	161	274
VAG96203	162	275
VAG96203	163	276
VAG96203	164	277
VAG96203	169	289
VAG96203	170	290

 <b>9</b>		
VAG96203	171	291
VAG96203	196	325
VAG96203	197	326
VAG96210	109	208
VAG96210	110	209
VAG96210	111	210
VAG96210	112	211
VAG96210	113	212
VAG96210	114	213
VAG96210	115	214
VAG96210	116	216
VAG96210	117	217
VAG96210	118	218
VAG96210	119	219
VAG96210	120	220
VAG96210	121	221
VAG96210	122	222
VAG96210	124	225
VAG96210	125	226
VAG96210	127	230
VAG96210	130	235
VAG96210	131	236
VAG96210	135	244
VAG96210	141	253
VAG96210	142	254
VAG96210	143	255
VAG96210	144	256
VAG96210	145	257
VAG96210	156	269
VAG96210	157	270
VAG96210	158	271
VAG96210	159	272
VAG96210	160	273
VAG96210	161	274
VAG96210	162	275
VAG96210	163	276
VAG96210	164	277
VAG96210	170	290
VAG96210	196	325
VAG96210	197	326
VAG96215B	288	499
VAG96215B	289	500
VAG96216B	71	142
VAG96216B	74	152
VAG96216B	75	154
VAG96216B	75	155
VAG96216B	76	157
VAG96216B	246	423
VAG96218	328	568
VAG96218	328	569
VAG96229	91	186
VAG96229	92	187
VAG96229	146	258
VAG96229	147	259
VAG96229	148	260
VAG96229	149	261
VAG96229	150	262
VAG96229	151	263
VAG96229	151	264
VAG96229	152	265

 <b>9</b>		
VAG96229	153	266
VAG96229	154	267
VAG96229	155	268
VAG96230	92	187
VAG96230	93	189
VAG96230	94	190
VAG96230	95	191
VAG96230	95	192
VAG96230	96	193
VAG96230	97	194
VAG96230	98	195
VAG96230	99	196
VAG96230	100	197
VAG96230	101	198
VAG96230	102	199
VAG96230	103	200
VAG96230	104	201
VAG96230	105	203
VAG96230	106	204
VAG96230	107	205
VAG96230	108	206
VAG96230	146	258
VAG96230	147	259
VAG96230	148	260
VAG96230	149	261
VAG96230	150	262
VAG96230	151	263
VAG96230	151	264
VAG96230	152	265
VAG96230	153	266
VAG96230	154	267
VAG96230	155	268
VAG96230	206	343
VAG96230	206	344
VAG96230	207	345
VAG96230	208	346
VAG96230	209	348
VAG96230	210	349
VAG96230	211	350
VAG96230	212	351
VAG96230	213	354
VAG96230	214	355
VAG96230	215	356
VAG96230	216	357
VAG96260B	213	353
VAG96260B	216	358
VAG96260B	217	359
VAG96260B	243	412
VAG96260B	245	422
VAG96260B	280	481
VAG96261	68	132
VAG96261	69	137
VAG96261	71	140
VAG96261	217	360
VAG96261	218	361
VAG96261	219	363
VAG96261	220	366
VAG96261	221	367
VAG96261	221	368
VAG96261	222	369

 <b>9</b>		
VAG96261	222	370
VAG96261	232	393
VAG96261	325	563
VAG96261	326	564
VAG96261	326	565
VAG96261	327	566
VAG96262	338	596
VAG96262	340	601
VAG96262	340	602
VAG96263	77	159
VAG96263	78	160
VAG96263	78	161
VAG96263	79	162
VAG96263	395	685
VAG96267	77	159
VAG96267	78	160
VAG96268	213	353
VAG96268	216	358
VAG96268	217	359
VAG96268	243	412
VAG96268	245	422
VAG96268	280	481
VAG96271B	329	570
VAG96272	28	51
VAG96272	28	52
VAG96272	29	53
VAG96272	31	57
VAG96272	34	60
VAG96272	35	61
VAG96272	39	66
VAG96272	42	73
VAG96272	44	77
VAG96273	32	58
VAG96273	33	59
VAG96273	37	63

# OE INTERCHANGE

OE-Vergleichsliste • Intercambio con OE

Références croisées 1ère Monte

OE	OE	OE	OE	OE	OE	OE	OE		
000023614	NF841	020349	BX900	0209R7	BY970	027109675	HR816	0607091710	AF240
0000530022	HR599	020457	HBS038	0209R8	BY982	030103085A	NA5001	0607328120	JD025
000111000	TB192	020468	HBS125	0209S5	BX880	030426	JJ283	0607550160	BE620
0003066V003000000	FOL190	020472	HBS087	0209S6	BX890	030434	JJ283	060755017	AN350
00039621840	HR805	020486	HBS272	0209S7	BX900	031326	PA349	0638196	NA5069
0039403920	NB866	020490	HBS261	0209S8	BX910	032627	NA5256	0641076	V98024
004634596	BY380	020493	HBS259	0209S9	BX920	034889	JC759	0641391	V98025
0060507576	JD015	020497	HBS084	0209T7	BX980	034896	JD529	0641392	V98025
0060516700	JA840	020498	HBS277	0209X0	AA5830	034898	JD5972	068103085A	NA5001
007603016303	PA349	0204A3	HBS535	0209X1	AA5840	0348C0	JC991	068103085E	NA5001
01143554	PA349	0204A4	HBS359	0209X2	AA5850	0348C8	JD536	06A129717	JD5291
01157880	PA349	0204C5x10	HBS359	0209X3	AA5860	0348F6	JD519	06J109423	FOL190
011913	NF867	020557x10	HBS359	0209X4	AA5870	0348H9	JC759	07119963244	PB907
011914	NF867	020904	BM530	0209X5	AC5012	0348J0	JC991	073109119A	TB192
012743	NA5325	020906	BL650	0209X6	AC5020	0348N1	HA5008	073109119C	TB192
012747	NA5191	02090S	AD5490	0209X7	AC5032	0348N1	JD6023	07724588	CAM648
012747	NA5192	02090T	AD5500	0209X8	AC5040	0348N2	HA5008	080155	CAM354
012749	NA5325	02090V	AD5510	0209X9	AC5052	0348N4	JD5191	0801C2	CAM354
016402	PA349	02090W	AD5520	0209Y5	BX930	0348P9	JD5907	0801E8	CAM373
016430	PA349	02090X	AH5040	0209Y6	BX940	0348Q0	JD5906	0801T5	CAM679
019713	GM533	02090Y	AH5060	0209Y7	BX950	0348R4	HA5030	0801V8	CAM681
019736	GJ720	02090Z	AH5050	0209Y7	BX970	0348R5	HA5031	0801V9	CAM751
019737	DJ720	02091A	AH5070	0209Y8	BX960	0348S3	HM5289	0801W0	CAM750
019742	EL650	02091C	AA5880	0209Y9	BX970	034903	JB841	080724	NA5260
019751	DM530	020920	BR510	0209Z3	AD5300	034946	JB869	080728	NA5035
019752	GM533	020921	BL650	021103051C	NA5305	034947	JC423	080729	NP067
019784	DM533	020923	BM530	022025	VAG51007	034949	JC415	080730	NA5258
019798	GM533	020935	BR510	022055	VAG92331B	034959	JC415	081616	TB114
019799	DM530	020956	BX900	022059	VAG92401	034970	JC415	081619	TB126
019799	DM533	020957	BX920	022060	VAG96132	034976	JD230	081622	TB175
0197AC	CD5500	020972	BR510	022064	VAG92332B	034978	JC423	081622	TB560
0197C4	GM533	020976	BM530	022065	VAG92288B	034994	JB841	081643	TB346
0197C6	DM530	020979	BR510	022075	VAG92288B	0349F0	JB869	081646	TB175
0197C9	DS820	0209A8	BL650	022076	VAG96160B	0349H4	JD5190	081646	TB560
0197E5	DV150	0209AJ	AD5130	022085	VAG96047	0349H7	JD5192	081648	TB346
0197E7	DV150	0209AK	AD5140	022095	VAG96271B	0349J8	JD5829	081648	TB419
0197F9	GJ720	0209AL	AD5150	0220A0	VAG96100	0349N0	JD5829	081654	TB320
0197G0	DJ720	0209AN	AD5160	0220A2	VAG96119	037103483AC	JN969	081658	TB175
0197G4	CY131	0209AP	AD5170	022109423	FOL154	0411187742	GS435	081658	TB560
0197H0	DV150	0209CJ	AD5701	022109423A	FOL154	0411227071	CG7490	081659	TB175
0197H1	DV150	0209CR	AH5060	022109423D	FOL154	0411287728	DS435	081660	TB346
0197H3	DS820	0209CS	AH5040	022117	VAG96056B	04153728	HR801	081660	TB419
0197H3	DY310	0209E1	BL650	022118	VAG96116B	04221154	HR801	081662	TB346
0197H4	DJ720	0209EA0209FS	AH6630	023280P	JM5088	0482401005	HR805	081662	TB419
0197H5	GJ720	0209EH	AH6390	023630	NF817	0490172008	NA5001	081663	TB278
0197J4	DM533	0209ES	AH6400	023644	NF817	049103051C	NF857	081669	TB454
0197J9	DM533	0209ET	AH6410	024099	HBS125	051103483A	JP024	081671	TB346
0197S1	DG542	0209F4	BM530	024914	JN244	051103483E	JP024	081671	TB419
0197S2	GG541	0209GL	AH7290	024945	JN426	051438	NF870	081673	TB479
0197T3	CY082	0209GN	AH7300	024946	JN544	051474	NF857	081679	TB305
0197T4	CY081	0209GP	AH7310	024948	JN547	05175440AA	FOL190	081689	TB727
0197T8	CY082	0209GQ	AH7320	024954	JN658	0591297176	JD5810	081693	TB631
0197V3	DR630	0209J8	BV140	024970	JP045	06005392	V91145	081696	TB632
0197X3	CC5010	0209K1	BX920	024978	JN426	0605041100	HR805	081698	TB479
0197X5	CA5830	0209L3	BR510	024983	JP049	0605066360	JD223	081699	TB368
0197Y2	GX410	0209L7	BL650	024991	JN544	0605071070	NA5066	0816A0	TB727
0197Y6	ED5490	0209L8	BR510	024995	JM5088	0605075570	HR646	0816A1	TB683
0197Y7	CD5490	0209L9	BY310	024999	JM5087	0605075760	JD015	0816A3	TB701
0197Y9	GX392	0209N3	BG540	0249A3	JM7121	0605129480	JN808	0816A4	TB558
0197Z4	GX392	0209N6	AY070	0249A4	JM5139	0605129490	JN807	0816A6	TB678
019806	DM530	0209N9	BY320	0249A5	JM5283	0605133160	JN812	0816A9	TB632
019811	DM710	0209P4	BY962	0249A6	JM5141	0605149100E4450	BP990	0816C2	TB683
019830	DM710	0209Q8	BX930	0249C1	JM5299	06051670000	JA840	0816E2	TB724
019837	DM530	0209Q9	BX940	0249C2	JM7034	0605212930	NB814	0816E4	TB720
019851	GM533	0209R0	BX950	0249E40249E5x2	HM5369	0605359490	HR801	0816E5	TB368
019864	GM533	0209R1	BX950	026103085A	NA5001	0605484480	BT340	0816E6	TB720
019872	DM530	0209R1	BX960	026103085F	NA5001	0605487510	BT380	0816E7	TB720
019888	GM533	0209R2	BX970	026106675	HR805	0605525770	BW410	0816F4	TB683
0198C3	GM533	0209R4	BY942	026107675	HR805	0605818460	AN350	0816G3	TB742
020012306A	HR599	0209R5	BY950	026109675	HR569	0605918100	BE620	0816G7	TB724
020012326A	HR800	0209R6	BY962	027109675	HR599	060596952	JD271	0816H3	TB727

OE		OE		OE		OE		OE	
0816J6	<b>TB724</b>	094960	<b>V94017</b>	107234	<b>AN350</b>	11676015080500	<b>BP260</b>	13177720	<b>HR646</b>
083106	<b>TBK010</b>	094964	<b>V94017</b>	108811	<b>BE620</b>	116760150806	<b>BK580</b>	131930000000	<b>V91621</b>
083111	<b>TBK035</b>	094964	<b>V94024</b>	1096253	<b>HR5082</b>	116760150806	<b>JC928</b>	132176	<b>BE620</b>
083117	<b>TBK010</b>	094966	<b>V91970</b>	11011030	<b>DR630</b>	11676015080600	<b>BK580</b>	132241	<b>BE620</b>
083122	<b>TBK035</b>	094968	<b>V94170</b>	110196	<b>JN588</b>	116760160100	<b>JC928</b>	13234000QA	<b>FOL190</b>
083127	<b>TBK020</b>	094973	<b>V94017</b>	11117805946	<b>NA5325</b>	1167601704	<b>JD025</b>	1346473	<b>TB720</b>
083131	<b>TBK020</b>	094974	<b>V94017</b>	11121262571	<b>HR397</b>	1167601704003	<b>JD025</b>	134697	<b>JD565</b>
083134	<b>TBK344</b>	094976	<b>V91971</b>	11127508936	<b>HBS359</b>	116760179903	<b>JF123</b>	1350607	<b>NA5192</b>
083135	<b>TBK344</b>	094992	<b>V94176</b>	11127805927	<b>JM7034</b>	116760330101	<b>V91438</b>	1350608	<b>NA5191</b>
083140	<b>TBK106</b>	094996	<b>V94179</b>	1114169600	<b>AG8180</b>	1167679901000	<b>GK570</b>	1352017	<b>NA5030</b>
083141	<b>TBK106</b>	094999	<b>V94201</b>	1114169601	<b>AG8180</b>	116797901300	<b>DK570</b>	1373250	<b>TB724</b>
083148	<b>TBK113</b>	0949A0	<b>V91994</b>	1114169602	<b>AG8180</b>	116850160100	<b>JD018</b>	13971330	<b>HBS052</b>
083149	<b>TBK113</b>	0949A3	<b>V94491</b>	1114169603	<b>AG8180</b>	117017901300	<b>CN306</b>	14009V5201	<b>JD152</b>
083152	<b>TBK035</b>	0949A5	<b>V94199</b>	11142249533	<b>NA5104</b>	117137901300	<b>CN306</b>	1414069000	<b>JD5965</b>
083153	<b>TBK035</b>	0949A9	<b>V94487</b>	1117453	<b>NA5030</b>	117177901300	<b>DH854</b>	1446647	<b>TB724</b>
083158	<b>TBK105</b>	0949E1	<b>V95084</b>	113028540	<b>HR805</b>	117187901000	<b>GC374</b>	14580R960030	<b>FOL190</b>
083159	<b>TBK105</b>	095605	<b>HR300</b>	113105245F	<b>NA784</b>	117187901300	<b>DC372</b>	14730110	<b>TB454</b>
083160	<b>TBK303</b>	095618	<b>HR569</b>	1131052456	<b>NA784</b>	119000150701	<b>JN807</b>	1473011080	<b>TB454</b>
083161	<b>TBK303</b>	095619	<b>HR569</b>	11317805957	<b>TB724</b>	119000150901	<b>JN808</b>	1487788	<b>FOL190</b>
083162	<b>TBK106</b>	095619	<b>HR646</b>	11321739299	<b>FOL129</b>	119000342201	<b>NA5163</b>	1489119	<b>TB720</b>
083178	<b>TBK274</b>	095622	<b>HR569</b>	11341273501	<b>HR569</b>	119020170400	<b>JD223</b>	1535493	<b>NA5057</b>
083179	<b>TBK274</b>	095622	<b>HR805</b>	11341273501	<b>HR596</b>	1192001508	<b>DK572</b>	1535494	<b>NA5057</b>
083182	<b>TBK106</b>	095624	<b>HR800</b>	11341285249	<b>HR569</b>	1192001508001	<b>DK572</b>	154020970400	<b>JD015</b>
083183	<b>TBK106</b>	095628	<b>HR599</b>	11341288544	<b>HR599</b>	1192079010	<b>DK572</b>	1556385	<b>TB192</b>
083188	<b>TBK279</b>	095628	<b>HR800</b>	11341288544	<b>HR646</b>	1192079010	<b>GK571</b>	1558385	<b>TB192</b>
083189	<b>TBK279</b>	095628	<b>HR816</b>	11341706580	<b>HR599</b>	119207901000	<b>GK571</b>	1576433	<b>PA349</b>
083192	<b>TBK338</b>	095648	<b>HR5046</b>	11341706707	<b>HR599</b>	12014726	<b>NP068</b>	1600500180	<b>FOL190</b>
0831K0	<b>TBK338</b>	10010001580701	<b>AF240</b>	11349059169	<b>HR363</b>	12015120	<b>NP068</b>	1606254	<b>CD5840</b>
0831K6	<b>TBK355</b>	1004928	<b>NA5001</b>	11349059169	<b>HR569</b>	12032063	<b>DK570</b>	1606465	<b>CD5820</b>
0831K7	<b>TBK355</b>	100552	<b>BG820</b>	11349059171	<b>HR646</b>	122060150801	<b>BP260</b>	1606537	<b>CH5240</b>
0831N2	<b>TBK105</b>	1007308	<b>FOL123</b>	11349059172	<b>HR602</b>	1229723	<b>TB724</b>	162060150800	<b>BK570</b>
0831N3	<b>TBK105</b>	101000150803	<b>AF240</b>	11349059172	<b>HR662</b>	1229877	<b>AD5130</b>	162060150801	<b>BP260</b>
0831N4	<b>TBK274</b>	101000150807	<b>AF240</b>	11349063193	<b>HR791</b>	1229880	<b>AD5160</b>	162060150802	<b>BK580</b>
0831N5	<b>TBK274</b>	101041	<b>JH565</b>	1142360	<b>NA5325</b>	1231931	<b>V94490</b>	1640200	<b>PA349</b>
090358	<b>FOL163</b>	101100150302	<b>VAG96216B</b>	1145950	<b>TB720</b>	1231976	<b>TB742</b>	164046	<b>JB841</b>
090364	<b>FOL163</b>	101827	<b>AN350</b>	1145953	<b>NA5258</b>	1231979	<b>TBK338</b>	16406015080001	<b>DK570</b>
09194750	<b>KG5337</b>	102078	<b>JA899</b>	1146061	<b>FOL190</b>	1235994	<b>JM7034</b>	1644647	<b>HR801</b>
094216	<b>FOL73</b>	102896000000	<b>V90392</b>	1148115	<b>JD5829</b>	1238067	<b>NA5031</b>	1663814	<b>NB959</b>
094225	<b>FOL109</b>	103331	<b>AN350</b>	115094	<b>BE620</b>	125065	<b>JH565</b>	1669254	<b>NA5177</b>
094228	<b>FOL126</b>	1037330	<b>FOL123</b>	115276	<b>JN588</b>	125196	<b>V91615</b>	1669785	<b>HR599</b>
094229	<b>FOL104</b>	1037331	<b>FOL123</b>	115309	<b>JA899</b>	1254375	<b>HA5030</b>	16806V7226	<b>TB146</b>
094232	<b>FOL164</b>	1043175	<b>FOL123</b>	116000120500	<b>JJ452</b>	1254376	<b>HA5031</b>	1683687	<b>AH7290</b>
094241	<b>FOL150</b>	1047213	<b>FOL151</b>	116000150800	<b>BC370</b>	1257221	<b>NA5001</b>	1683688	<b>AH7300</b>
094242	<b>FOL190</b>	105000117600	<b>NA5066</b>	11600015080001	<b>BC370</b>	12572210	<b>NA5001</b>	1683689	<b>AH7310</b>
094249	<b>FOL115</b>	105000117602	<b>NA5066</b>	116000150801	<b>BC370</b>	12575793	<b>V94962</b>	1683690	<b>AH7320</b>
094251	<b>FOL190</b>	105000150304	<b>VAG92168B</b>	116000150803	<b>BC370</b>	1273501	<b>HR596</b>	1684287	<b>NA5030</b>
094252	<b>FOL190</b>	105000150803	<b>AF370</b>	116001150800	<b>BC370</b>	1276166600	<b>TB175</b>	17065804	<b>HR599</b>
094253	<b>FOL190</b>	10500015080301	<b>AF370</b>	116003016501	<b>JE696</b>	1276166600	<b>TB560</b>	17067073	<b>HR599</b>
094833	<b>V34459</b>	105000170400	<b>JA829</b>	1160030165010	<b>JE696</b>	1276167600	<b>TB632</b>	171009	<b>JE647</b>
094856	<b>V91277</b>	10500150800	<b>AF370</b>	116010172000	<b>JE696</b>	1276167J00	<b>TB720</b>	17100900	<b>JE647</b>
094858	<b>V91271</b>	10500150803	<b>AF370</b>	116011	<b>BC370</b>	1276179J50	<b>TB639</b>	17779904	<b>BW340</b>
094859	<b>V91144</b>	1050369	<b>AY400</b>	116013	<b>BC370</b>	1276186CA0	<b>TB175</b>	1900209	<b>CM870</b>
094863	<b>V91144</b>	1050370	<b>AY410</b>	1160150800	<b>BC370</b>	1276186CA0	<b>TB560</b>	1900235	<b>FG615</b>
094866	<b>V91972</b>	1050371	<b>AY420</b>	116080150804	<b>BH850</b>	1276186CT0	<b>TB560</b>	1900812	<b>CG01A</b>
094868	<b>V94169</b>	10512013	<b>AN300</b>	11608015080401	<b>BH850</b>	1288544	<b>HR646</b>	1904915	<b>JC055</b>
094892	<b>V94175</b>	105120150800	<b>AN300</b>	116080330101	<b>V90388</b>	1289167601000	<b>FOL190</b>	1905933	<b>DR073</b>
094894	<b>V91144</b>	10512015080001	<b>AN300</b>	11608701300	<b>BH850</b>	1289185E00	<b>FOL187</b>	1907799	<b>DR073</b>
094894	<b>V94154</b>	105120150801	<b>AN300</b>	11612777	<b>HR397</b>	1291169600	<b>V95007</b>	1907799	<b>DS381</b>
094895	<b>V94178</b>	105120150805	<b>AN300</b>	11627806008	<b>JD5829</b>	1291185E00	<b>V95015</b>	1907801	<b>DS381</b>
094899	<b>V94200</b>	1051401507	<b>JP004</b>	11633011	<b>AN300</b>	1291569650	<b>V95008</b>	1907802	<b>DS381</b>
0948A2	<b>V91292</b>	105140150701	<b>JP004</b>	116330150800	<b>AN300</b>	1291585E00	<b>V95016</b>	1908009	<b>DE588</b>
0948A3	<b>V94490</b>	105260150800	<b>AF370</b>	1163679013	<b>CN306</b>	129661	<b>V91614</b>	1908015	<b>DR073</b>
0948A5	<b>V94198</b>	105390150800	<b>AF240</b>	116550117601	<b>NA5066</b>	13028V7226	<b>TB146</b>	1908408	<b>V91301</b>
0948C0	<b>V94486</b>	105390160100	<b>JA840</b>	116760150800	<b>DK570</b>	130455	<b>BP990</b>	1908409	<b>V91304</b>
0948E5	<b>V95083</b>	1054101601	<b>JA840</b>	116760150802	<b>BK570</b>	1306630	<b>HR801</b>	1908410	<b>V91302</b>
0948E6	<b>V98028</b>	105410160100	<b>JA840</b>	11676015080200	<b>BK570</b>	131510403	<b>KV086</b>	195100120500	<b>JJ451</b>
094921	<b>V34460</b>	105410160101	<b>JA840</b>	116760150803	<b>BK580</b>	131512408	<b>KV102</b>	195170160100	<b>JC497</b>
094947	<b>V91145</b>	105480150800	<b>BH850</b>	11676015080300	<b>BK580</b>	131571	<b>JN333</b>	1951708601	<b>JC497</b>
094947	<b>V94017</b>	10548015080001	<b>BH850</b>	116760150804	<b>BK570</b>	1316801M00	<b>NJ951</b>	195240351100	<b>JN806</b>
094957	<b>V91275</b>	105480330101	<b>V90388</b>	11676015080400	<b>BK570</b>	1317772	<b>HR646</b>	195260860100	<b>JD018</b>
094959	<b>V91273</b>	107028	<b>JH565</b>	116760150805	<b>BP260</b>	13177720	<b>HR599</b>	195360351101	<b>JN812</b>

# OE INTERCHANGE

OE-Vergleichsliste • Intercambio con OE  
Références croisées 1ère Monte

OE	OE	OE	OE	OE	OE	OE	OE	OE	OE
195590330100	<b>V91437</b>	26109675	<b>HR805</b>	3M5Q6L004AA	<b>HA5030</b>	4249510	<b>JJ078</b>	4435023	<b>BK540</b>
195590970400	<b>JD025</b>	2992531	<b>FB5721</b>	3M5Q6L004BA	<b>HA5031</b>	4249510	<b>JJ440</b>	4436580	<b>JC738</b>
1973600	<b>GJ720</b>	2995573	<b>CG7300</b>	3M5Q8A615BA	<b>TBK338</b>	4250801	<b>VAG96171</b>	4440061	<b>V91765</b>
1973700	<b>DJ720</b>	2995608	<b>FB5721</b>	3S7Q6700AA	<b>NA5031</b>	4250803	<b>VAG92366</b>	444409	<b>BP110</b>
1975100	<b>DM530</b>	2995609	<b>CB5720</b>	40000040	<b>NA784</b>	42531636	<b>NP067</b>	4444408	<b>BP110</b>
1980600	<b>DM530</b>	2S6Q6500AA	<b>FOL190</b>	40000160	<b>NA5045</b>	42531636	<b>NP068</b>	4444409	<b>BP110</b>
1983000	<b>DM710</b>	2S6Q6500AB	<b>FOL190</b>	40003300	<b>NA5045</b>	4256857	<b>JM508</b>	4444450	<b>BP110</b>
1983700	<b>DM530</b>	2S6Q6701AA	<b>NA5325</b>	40003300	<b>NB728</b>	4258405	<b>JM663</b>	4446715	<b>JJ136</b>
19850	<b>DM530</b>	2S6Q6K288AA	<b>TB720</b>	40003630	<b>NP068</b>	4265695	<b>V34457</b>	4448165	<b>LT439</b>
1985000	<b>DM530</b>	2S6Q6K288AB	<b>TB720</b>	40003634	<b>NP068</b>	4265699	<b>VAG92364</b>	4448401	<b>BP110</b>
20380025A	<b>VAG96187</b>	2S6Q6K288AC	<b>TB720</b>	40003637	<b>NP068</b>	4265701	<b>HR599</b>	4448677	<b>JM663</b>
20459855	<b>HR801</b>	2S6Q6L270AA	<b>NA5258</b>	40003640	<b>NP068</b>	4266321	<b>V34654</b>	4448010	<b>BG830</b>
20489	<b>HBS260</b>	30003780	<b>HR800</b>	40003650	<b>NP067</b>	4268806	<b>JM508</b>	4462674	<b>JC287</b>
20496	<b>HBS272</b>	3036117	<b>CAM391</b>	40003657	<b>NP067</b>	4271052	<b>JE480</b>	4464012	<b>KG393</b>
2090400	<b>BM530</b>	3042600	<b>JJ283</b>	40003850	<b>NF833</b>	4279436	<b>JC054</b>	4464457	<b>LT439</b>
2090600	<b>BL650</b>	30711488	<b>NA5325</b>	40003990	<b>NA5049</b>	4279438	<b>JC055</b>	4467939	<b>BP050</b>
2091016	<b>PA349</b>	30757227	<b>NA5191</b>	40004000	<b>NA5050</b>	4287796	<b>BP070</b>	4467996	<b>BJ860</b>
2092100	<b>BL650</b>	30757227	<b>NA5192</b>	40004000	<b>NA784</b>	4291098	<b>BP190</b>	4467997	<b>BJ870</b>
2092300	<b>BM530</b>	3101048	<b>JB851</b>	40004190	<b>NB814</b>	4294098	<b>V91739</b>	4467998	<b>BJ880</b>
20958	<b>BL650</b>	31010481	<b>JB851</b>	40004200	<b>NB815</b>	4306719	<b>JM674</b>	4468200	<b>BP050</b>
2095800	<b>BL650</b>	310620315	<b>HR800</b>	40004250	<b>NB742</b>	4309031	<b>JD146</b>	4468501	<b>JA777</b>
21011007026	<b>HR363</b>	310620353	<b>HR800</b>	40004260	<b>NB825</b>	4314165	<b>BP130</b>	4469751	<b>HBS051</b>
21011007026	<b>HR596</b>	31164	<b>HR599</b>	40004270	<b>NB818</b>	4315062	<b>V91713</b>	4469752	<b>HBS051</b>
21011203020	<b>JE390</b>	31258204	<b>NA5325</b>	40004290	<b>NA784</b>	4323710	<b>JN283</b>	4469882	<b>BP070</b>
2103120302001	<b>JE390</b>	31259224	<b>NA5325</b>	40004300	<b>NB644</b>	4330005	<b>BP190</b>	4469883	<b>BP110</b>
21081007026	<b>HR805</b>	3210061	<b>BE580</b>	40004300	<b>NB732</b>	4331606	<b>JH111</b>	4500831	<b>TB368</b>
2112100604002	<b>TB479</b>	3210112	<b>BR070</b>	40004340	<b>NA5051</b>	4340118	<b>V90064</b>	4500879	<b>VB558</b>
2116910	<b>NA784</b>	321103	<b>HR800</b>	40004370	<b>NA5052</b>	4340119	<b>V90399</b>	4501807	<b>TBK102</b>
21501189	<b>HR801</b>	3214136	<b>BR070</b>	40004400	<b>NA5053</b>	4341243	<b>BP130</b>	4502789	<b>GX392</b>
220081	<b>VAG96215B</b>	3214139	<b>BE580</b>	40004750	<b>NA5177</b>	4349222	<b>JN406</b>	4503983	<b>NC006</b>
22022072F	<b>AY400</b>	3277158	<b>NF722</b>	40004930	<b>NA5187</b>	4357028	<b>HR599</b>	46400045	<b>TB471</b>
22022073F	<b>AY410</b>	32771583	<b>NF722</b>	40005010	<b>NB825</b>	4358713	<b>CAM517</b>	46402972	<b>AY430</b>
22022074F	<b>AY420</b>	32978850	<b>JB851</b>	40100070	<b>NP067</b>	4358946	<b>NB732</b>	46402972J	<b>AY430</b>
22022078F	<b>JD5144</b>	3310742	<b>BR510</b>	40100080	<b>NP068</b>	4359309	<b>V90070</b>	46403659	<b>TB637</b>
22022080F	<b>AY400</b>	3313E003	<b>VAG701</b>	40100300	<b>NA5055</b>	4369825	<b>JD019</b>	46403681	<b>V94029</b>
22022081F	<b>AY410</b>	3314488	<b>BP290</b>	40100301	<b>NB946</b>	4370933	<b>HR596</b>	46404034	<b>NA5057</b>
22022082F	<b>AY420</b>	33261723	<b>VAG586</b>	40100311	<b>NF833</b>	4372331	<b>VAG50895</b>	46404094	<b>NA5057</b>
22030362A	<b>JN581</b>	33261742	<b>VAG701</b>	40100314	<b>NF833</b>	4374855	<b>V91712</b>	46407749	<b>V94576</b>
22032114F	<b>JD025</b>	33442617	<b>HR569</b>	40100320	<b>NP067</b>	4377979	<b>V91282</b>	46410505	<b>JD340</b>
22032152	<b>BK570</b>	3490300	<b>JB841</b>	40100320	<b>NP068</b>	4379220	<b>BP190</b>	46410880	<b>JD342</b>
22032152F	<b>BK570</b>	3494600	<b>JB869</b>	40100321	<b>NP068</b>	4379970	<b>BD790</b>	46410890	<b>JD342</b>
22032153	<b>BP260</b>	3494700	<b>JC423</b>	40100324	<b>NP068</b>	4379970	<b>BD800</b>	46410891	<b>JD342</b>
22032153F	<b>BP260</b>	3494900	<b>JC415</b>	40100330	<b>NP067</b>	4386291	<b>TB388</b>	46410891	<b>JD343</b>
22032154	<b>BK580</b>	3495900	<b>JC415</b>	40100330	<b>NP068</b>	4387611	<b>AM870</b>	46410960	<b>BX030</b>
22032154F	<b>BK580</b>	3501775	<b>HR805</b>	40100331	<b>NP067</b>	4387612	<b>AH020</b>	46411495	<b>FOL100</b>
22032185F	<b>BK570</b>	35017755	<b>HR805</b>	40100331	<b>NP068</b>	4387618	<b>BP070</b>	46412116	<b>JD5143</b>
22032186F	<b>BP260</b>	3517860	<b>HR599</b>	40100334	<b>NP067</b>	4387623	<b>BP190</b>	46413078	<b>FOL145</b>
22032187F	<b>BK580</b>	35178607	<b>HR646</b>	40100340	<b>NP068</b>	4387624	<b>BP130</b>	46414221	<b>BT300</b>
22032245G	<b>JP068</b>	3517893	<b>HR599</b>	40101524	<b>NF886</b>	4388512	<b>JM508</b>	46414221	<b>BT320</b>
2206154	<b>NA784</b>	35178938	<b>HR800</b>	4047071	<b>JA755</b>	4390870	<b>JM508</b>	46414437	<b>JD228</b>
222312A000	<b>FOL190</b>	353722	<b>V91679</b>	4117850	<b>JM333</b>	4391213	<b>BP070</b>	46414438	<b>JD343</b>
22454009R	<b>PA349</b>	3681E066	<b>AH020</b>	4124546	<b>AM870</b>	4392929	<b>BG820</b>	46414567	<b>AY460</b>
22472090	<b>PA349</b>	3681E067	<b>AH020</b>	4127971	<b>JC973</b>	4394109	<b>JN459</b>	46414567	<b>BR630</b>
2249533	<b>NA5104</b>	3681E068	<b>AH020</b>	4128615	<b>JM490</b>	4398359	<b>JD5155</b>	46416033	<b>BT300</b>
23614	<b>NF841</b>	3681E069	<b>AH020</b>	4142114	<b>NA784</b>	4403027	<b>TB368</b>	46416034	<b>BT320</b>
2361400	<b>NF841</b>	3681E070	<b>AH020</b>	4145587	<b>JM333</b>	4403047	<b>V91762</b>	46416876	<b>NF887</b>
2434129000	<b>TB175</b>	3681E071	<b>AH020</b>	4147260	<b>JE390</b>	4404985	<b>NA5187</b>	46420638	<b>HBS130</b>
2434129000	<b>TB560</b>	3681E072	<b>AH020</b>	4150660	<b>JM508</b>	4406740	<b>BP070</b>	46423334	<b>V91928</b>
24405815	<b>V98025</b>	3681E073	<b>AH020</b>	4151277	<b>JA757</b>	4407095	<b>BD790</b>	46425904	<b>JD464</b>
24422964	<b>TB741</b>	3681E074	<b>AH020</b>	4152447	<b>FOL104</b>	441054151716	<b>HR599</b>	46425908	<b>JD465</b>
24454518	<b>V94963</b>	3681E075	<b>AH020</b>	4158646	<b>JM085</b>	4412816	<b>V90398</b>	46426046	<b>JD148</b>
24465791	<b>NA5174</b>	3681E076	<b>AH020</b>	4177112	<b>JA757</b>	4424154	<b>JN669</b>	46426755	<b>AY320</b>
2461003000	<b>FOL190</b>	3681E077	<b>AH020</b>	4179038	<b>JH494</b>	4424173	<b>V91763</b>	46426983	<b>TB639</b>
2491400	<b>JN244</b>	39403920	<b>NB866</b>	4179084	<b>BP070</b>	4431246	<b>FOL187</b>	46427282	<b>FOL161</b>
2494500	<b>JN426</b>	3M5Q6507BA	<b>V94490</b>	4179085	<b>JN805</b>	4431246	<b>FOL190</b>	46427653	<b>JD343</b>
2494600	<b>JN544</b>	3M5Q6700BC	<b>NA5191</b>	4179112	<b>JA757</b>	4431654	<b>BP110</b>	46430687	<b>HBS051</b>
2494800	<b>JN547</b>	3M5Q6700BC	<b>NA5192</b>	4194060	<b>JA777</b>	4434846	<b>BP510</b>	46430688	<b>HBS051</b>
2495400	<b>JN658</b>	3M5Q6K288AA	<b>TB724</b>	4194300	<b>BP030</b>	4434846M	<b>BP500</b>	46431639	<b>BV680</b>
254705116312	<b>TB175</b>	3M5Q6K288AB	<b>TB724</b>	4195130	<b>JM663</b>	4434864	<b>BP110</b>	46431640	<b>BT230</b>
258458	<b>JN333</b>	3M5Q6K288BA	<b>TB742</b>	4216787	<b>BP030</b>	4434865	<b>BP110</b>	46431640	<b>BV690</b>
2584589	<b>JN333</b>	3M5Q6K288CA	<b>TB724</b>	4239917	<b>V34496</b>	4434903	<b>BP050</b>	46431641	<b>BV700</b>

OE		OE		OE		OE		OE	
46431642	<b>BR700</b>	46475925	<b>FOL187</b>	46774708	<b>CAM717</b>	5001000816	<b>NA784</b>	504018307	<b>JH5077</b>
46431642	<b>BT240</b>	46477509	<b>JF184</b>	46774976	<b>AD5960</b>	5001000816	<b>NP068</b>	504019494	<b>JM5201</b>
46431642	<b>BV700</b>	46480910	<b>JA752</b>	46780505	<b>TB639</b>	5001001151	<b>NF833</b>	504022754	<b>JD5981</b>
46431642	<b>BW980</b>	46513955	<b>JM5176</b>	46783962	<b>V94471</b>	5001001215	<b>HBS011</b>	504031409	<b>NF885</b>
46432087	<b>JP063</b>	46514671	<b>TB471</b>	46787055	<b>FOL106</b>	5001001216	<b>HBS011</b>	504034832	<b>NF885</b>
46432735	<b>JD150</b>	46514710	<b>HA5005</b>	46787902	<b>V94589</b>	5001001231	<b>BE580</b>	504037859	<b>JD5338</b>
46433782	<b>VAG96124</b>	46514722	<b>HA5005</b>	46791187	<b>TB608</b>	5001001234	<b>JN462</b>	504049360	<b>FB5722</b>
46434102	<b>BV670</b>	46514754	<b>V94216</b>	46791188	<b>TB639</b>	5001001254	<b>NP067</b>	504049362	<b>CB5720</b>
46434591	<b>NA5058</b>	46515401	<b>TB660</b>	46791189	<b>TB725</b>	5001001267	<b>TB135</b>	504052452	<b>JM5202</b>
46434596	<b>BY380</b>	46517325	<b>V91949</b>	46802049	<b>V94588</b>	5001001283	<b>JC054</b>	504059361	<b>NF883</b>
46435513	<b>NF888</b>	46518930	<b>V95015</b>	46802420	<b>CAM714</b>	5001001581	<b>VAG92369</b>	504069199	<b>V94592</b>
46436047	<b>HR599</b>	46518931	<b>V95016</b>	46811291	<b>JA5035</b>	5001823706	<b>BR070</b>	504069199	<b>V98018</b>
46437256	<b>JP064</b>	46522371	<b>CAM713</b>	46814120	<b>JM5176</b>	5001829815	<b>AY590</b>	504069200	<b>V91292</b>
46440885	<b>HR800</b>	46523711	<b>CAM653</b>	46814174	<b>JM7055</b>	5001829882	<b>JN594</b>	504072531	<b>V98042</b>
46441525	<b>VAG96272</b>	46525557	<b>JD226</b>	46814175	<b>JM7117</b>	5001836510	<b>GX410</b>	504076915	<b>TB723</b>
46442435	<b>AY550</b>	46526271	<b>JA5006</b>	46815383	<b>FOL168</b>	5001836511	<b>DX391</b>	504081062	<b>V98043</b>
46442436	<b>AY560</b>	46526291	<b>TB649</b>	46817515	<b>AD5800</b>	5001836513	<b>DX390</b>	504093499	<b>AG6060</b>
46442437	<b>AY570</b>	46527523	<b>JD225</b>	46817516	<b>AD5810</b>	5001836605	<b>TB368</b>	504093500	<b>AG6050</b>
46444964	<b>BT860</b>	46529117	<b>BZ791</b>	46817517	<b>AD5820</b>	5001836608	<b>TB558</b>	504093501	<b>AG7300</b>
46447765	<b>AY520</b>	46529118	<b>BZ801</b>	46820225	<b>JD5143</b>	5001847819	<b>TB701</b>	504123772	<b>NA5202</b>
46448011	<b>FOL168</b>	46529119	<b>BZ811</b>	46823507	<b>CAM712</b>	5001853924	<b>NP067</b>	504378070	<b>V94593</b>
46449944	<b>AY530</b>	46530228	<b>CAM709</b>	46823508	<b>CAM711</b>	500306170	<b>AY680</b>	5111410040	<b>BX040</b>
46449945	<b>AY540</b>	46530233	<b>CAM710</b>	4697094	<b>AN350</b>	500306171	<b>AY690</b>	5111410300	<b>BX040</b>
46451593	<b>AC5140</b>	46533298	<b>V94591</b>	4716458	<b>NP067</b>	500306172	<b>AY700</b>	5111410570	<b>BX040</b>
46451593	<b>BV680</b>	46539824	<b>LK5001</b>	4716750	<b>NP068</b>	500314225	<b>NF883</b>	5111410830	<b>BX040</b>
46451594	<b>AC5150</b>	46541065	<b>TB462</b>	4721234	<b>TB146</b>	500315684	<b>NF885</b>	5120058	<b>JM5028</b>
46451594	<b>BV690</b>	46541379	<b>BP290</b>	4722674	<b>LS856</b>	500316112	<b>JJ613</b>	5233315	<b>FOL38</b>
46451595	<b>AC5180</b>	46546120	<b>AE5240</b>	4722675	<b>LS857</b>	500317403	<b>JN956</b>	5403212	<b>HR340</b>
46451595	<b>BV700</b>	46548288	<b>TB608</b>	4726483	<b>VAG92194</b>	500327440	<b>JH5178</b>	5412007	<b>HR340</b>
46451596	<b>AC5160</b>	46548441	<b>JM5003</b>	4731124	<b>BE580</b>	500350049	<b>NA5201</b>	5452930	<b>JH869</b>
46451596	<b>BW980</b>	46548450	<b>JA5008</b>	4732165	<b>LS856</b>	500354411	<b>CY680</b>	54529300	<b>JB869</b>
46452670	<b>BT300</b>	46548459	<b>JA5011</b>	4732166	<b>LS857</b>	500362855	<b>V94592</b>	5469955	<b>HR340</b>
46452670	<b>BT320</b>	46549807	<b>AA5590</b>	4733258	<b>VAG92369</b>	500362856	<b>V94593</b>	5494183	<b>BG540</b>
46454063	<b>BY410</b>	46552748	<b>JM5028</b>	4733348	<b>V90402</b>	500362856	<b>V98019</b>	5500387068	<b>AB5730</b>
46454064	<b>BE450</b>	46552984	<b>CAM417</b>	4733349	<b>V90404</b>	500366171	<b>GX390</b>	5500387069	<b>AB5740</b>
46454065	<b>BY430</b>	46556651	<b>HR5088</b>	4733350	<b>FOL169</b>	500366181	<b>DX400</b>	55180937	<b>NA5230</b>
46455736	<b>CAM651</b>	4658055	<b>V91667</b>	4738019	<b>JN462</b>	500366511	<b>GX390</b>	55183371	<b>AG7380</b>
46457061	<b>TB660</b>	4659379	<b>V91676</b>	4741124	<b>BE580</b>	500366528	<b>DX391</b>	55183446	<b>TB787</b>
46457742	<b>TB608</b>	46641908	<b>HR800</b>	4741822	<b>BE580</b>	500366848	<b>FY690</b>	55183528	<b>BT790</b>
46460125	<b>NF888</b>	4667156	<b>NF886</b>	4749395	<b>VAG92373</b>	500369482	<b>FY691</b>	55184024	<b>AG6220</b>
46461209	<b>V94468</b>	4673608	<b>V91667</b>	4749397	<b>VAG92193</b>	500369483	<b>CY680</b>	55184740	<b>AG7410</b>
46461755	<b>JD467</b>	46736500	<b>TB649</b>	4757358	<b>V91292</b>	500371975	<b>TB723</b>	55184741	<b>AG7420</b>
46461883	<b>BW340</b>	46736501	<b>TB676</b>	4784888	<b>V91301</b>	500376626	<b>JD5337</b>	55184742	<b>AG7430</b>
46461884	<b>BW350</b>	46737936	<b>JC738</b>	4784889	<b>V91302</b>	500383471	<b>AB5720</b>	55185028	<b>V98026</b>
46461885	<b>BW360</b>	46739135	<b>AA5780</b>	4784890	<b>V91304</b>	500383472	<b>AB5730</b>	55185080	<b>V98027</b>
46462159	<b>V91950</b>	46739136	<b>AA5790</b>	4802126	<b>VAG92444</b>	500383473	<b>AB5740</b>	55185775	<b>AD5830</b>
46462481	<b>BT260</b>	46739137	<b>AA5800</b>	4803805	<b>V91301</b>	500387067	<b>AB5720</b>	55187103	<b>BT725</b>
46462772	<b>JC738</b>	46739261	<b>JM5029</b>	4806718	<b>V91302</b>	500387068	<b>AB5730</b>	55187650	<b>AD5970</b>
46464114	<b>JM5018</b>	46743167	<b>HR5095</b>	4813760	<b>V91399</b>	500387069	<b>AB5740</b>	55187704	<b>AD5870</b>
46465291	<b>JF145</b>	46749904	<b>AA5561</b>	4826033	<b>V91293</b>	500391047	<b>AY700</b>	55187705	<b>AD5960</b>
46465330	<b>FOL145</b>	46749905	<b>AA5571</b>	4828150	<b>HBS011</b>	5012820	<b>DM530</b>	55187899	<b>AD5800</b>
46465430	<b>FOL106</b>	46749906	<b>AA5581</b>	4830224	<b>HR602</b>	5012839	<b>DM710</b>	55187900	<b>AD5810</b>
46467203	<b>JN973</b>	46750859	<b>V94470</b>	4832015	<b>BR090</b>	5012840	<b>DP070</b>	55187901	<b>AD5820</b>
46467746	<b>JD228</b>	46750865	<b>TB676</b>	4834948	<b>BF123</b>	5012841	<b>DP130</b>	55188191	<b>TB471</b>
46467747	<b>JD468</b>	46752127	<b>AB5150</b>	4837051	<b>AB5100</b>	5012847	<b>DP190</b>	55189864	<b>AE5240</b>
46468413	<b>AA5720</b>	46754320	<b>JD148</b>	4837141	<b>JC055</b>	5012871	<b>DP011</b>	55189950	<b>AE5240</b>
46468413	<b>BW340</b>	46757318	<b>JD150</b>	4837347	<b>DS381</b>	5012877	<b>DP110</b>	55189962	<b>AA5420</b>
46468414	<b>AA5730</b>	46757321	<b>JD464</b>	4837349	<b>DS381</b>	5012927	<b>DM530</b>	55189997	<b>NA5321</b>
46468415	<b>AA5740</b>	46757609	<b>JD465</b>	4848254	<b>BR090</b>	5012942	<b>DJ852</b>	55190350	<b>AD5840</b>
46470334	<b>HR814</b>	46759989	<b>JM5019</b>	4854648	<b>HBS011</b>	5012947	<b>DG811</b>	55190351	<b>AD5850</b>
46471599	<b>FOL101</b>	46764378	<b>V94065</b>	4854648	<b>HBS255</b>	5012994	<b>JN283</b>	55190352	<b>AD5860</b>
46471639	<b>V94030</b>	46764762	<b>HBS371</b>	4862154	<b>NF886</b>	5012996	<b>JM085</b>	55190353	<b>AD5910</b>
46473173	<b>CAM652</b>	46765629	<b>FOL168</b>	4891275	<b>BP510</b>	5012999	<b>JM333</b>	55190354	<b>AD5920</b>
46473174	<b>BE440</b>	46767211	<b>AD5970</b>	4891275	<b>FOL190</b>	5013001	<b>JN244</b>	55190355	<b>AD5930</b>
46473175	<b>BE450</b>	46771926	<b>AD5840</b>	5000296030	<b>DS381</b>	5013009	<b>JM663</b>	55190356	<b>AG7390</b>
46473175	<b>BY420</b>	46771927	<b>AD5850</b>	5000814593	<b>TB135</b>	5013044	<b>JN459</b>	55190357	<b>AG7400</b>
46473176	<b>BE460</b>	46771928	<b>AD5860</b>	5000815434	<b>NP067</b>	5013062	<b>JN462</b>	55190358	<b>AG7440</b>
46473176	<b>BY430</b>	46772389	<b>JA5035</b>	5000815434	<b>NP068</b>	5013178	<b>BG820</b>	55190359	<b>AA5780</b>
46473336	<b>AY460</b>	46772390	<b>JA5036</b>	5000815452	<b>BR070</b>	5013179	<b>BG830</b>	55190360	<b>AA5790</b>
46475573	<b>HBS297</b>	46772393	<b>CAM654</b>	5001000786	<b>NA784</b>	504014155	<b>NA5202</b>	55190361	<b>AA5800</b>
46475574	<b>HBS297</b>	46774707	<b>CAM716</b>	5001000786	<b>NB946</b>	504017372	<b>JJ613</b>	55192156	<b>V98003</b>

# OE INTERCHANGE

OE-Vergleichsliste • Intercambio con OE  
Références croisées 1ère Monte

OE		OE		OE		OE		OE	
55192265	<b>HBS353</b>	5636343	<b>TB639</b>	5882634	<b>DR100</b>	5890584	<b>DT446</b>	5891288	<b>AM870</b>
55192551	<b>AY320</b>	5636344	<b>TB790</b>	5882669	<b>GP861</b>	5890585	<b>GT446</b>	5891289	<b>BP290</b>
55192896	<b>TB639</b>	5636436	<b>TB741</b>	5882674	<b>DP860</b>	5890586	<b>DT446</b>	5891290	<b>BK540</b>
55193659	<b>TB794</b>	5636452	<b>TB741</b>	5882781	<b>GP871</b>	5890587	<b>GT446</b>	5891297	<b>BG820</b>
55194045	<b>JM5176</b>	5636463	<b>TB639</b>	5882782	<b>DP871</b>	5890640	<b>GP282</b>	5891298	<b>BG830</b>
55194219	<b>V98022</b>	5850345	<b>JD5982</b>	5882900	<b>GK590</b>	5890642	<b>GP282</b>	5891300	<b>BR070</b>
55194993	<b>V98020</b>	5850674	<b>JD5411</b>	5888178	<b>DR480</b>	5890643	<b>GT400</b>	5891302	<b>BR090</b>
55194994	<b>V98021</b>	5878103590	<b>GS435</b>	5888179	<b>GR480</b>	5890645	<b>GR620</b>	5891303	<b>BP520</b>
55195680	<b>V95015</b>	5880010	<b>DP130</b>	5888217	<b>GP282</b>	5890646	<b>DR620</b>	5891307	<b>BT420</b>
55195892	<b>AD5840</b>	58800958	<b>DD790</b>	5888241	<b>DR610</b>	5890649	<b>GR630</b>	5891308	<b>BT410</b>
55195910	<b>AD5850</b>	5880416	<b>GP011</b>	5888261	<b>GR620</b>	5890650	<b>DR630</b>	5891321	<b>JE480</b>
55195911	<b>AD5860</b>	5880417	<b>DP011</b>	5888262	<b>DR620</b>	5890651	<b>GP861</b>	5891342	<b>GR611</b>
55197283	<b>AD5830</b>	5880420	<b>FM872</b>	5888318	<b>GR630</b>	5890653	<b>DP689</b>	5891343	<b>DR611</b>
55197598	<b>JM5204</b>	5880421	<b>CM870</b>	5888319	<b>DR630</b>	5890655	<b>DP689</b>	5891633	<b>DR480</b>
55197682	<b>JD5375</b>	5880424	<b>FG615</b>	5888447	<b>DP292</b>	5890657	<b>DT446</b>	5891634	<b>GR480</b>
55198843	<b>AD5800</b>	5880434	<b>FN402</b>	5888526	<b>DP689</b>	5890658	<b>GT446</b>	5891657	<b>GT260</b>
55198844	<b>AD5810</b>	5880435	<b>CN400</b>	5888534	<b>GT300</b>	5890664	<b>DT446</b>	5891658	<b>DT260</b>
55198845	<b>AD5820</b>	5880451	<b>DP130</b>	5888535	<b>DT300</b>	5890665	<b>GT446</b>	5891780	<b>BP520</b>
55199355	<b>JD5375</b>	5880639	<b>GP01A</b>	5888591	<b>DT441</b>	5890670	<b>DT446</b>	5891781	<b>BP030</b>
55200422	<b>V98023</b>	5880661	<b>DP070</b>	5888632	<b>DV680</b>	5890671	<b>GT446</b>	5891791	<b>BD790</b>
55200890	<b>AD5840</b>	5880662	<b>GP070</b>	5888634	<b>DT290</b>	5890672	<b>GT423</b>	5891795	<b>GP011</b>
55200891	<b>AG7390</b>	5880858	<b>GD671</b>	5888652	<b>BP520</b>	5890673	<b>DT423</b>	5891796	<b>DP011</b>
55201694	<b>AD5850</b>	5880858	<b>GD790</b>	5888653	<b>BP510</b>	5890674	<b>DT446</b>	5891797	<b>FM872</b>
55201695	<b>AD5860</b>	5880860	<b>DD790</b>	5888656	<b>BP070</b>	5890676	<b>DT413</b>	5891798	<b>GR480</b>
55202010	<b>AG7400</b>	5880948	<b>BD790</b>	5888657	<b>BP110</b>	5890678	<b>DT420</b>	5891801	<b>GK590</b>
55202011	<b>AG7440</b>	5880950	<b>AM870</b>	5888661	<b>BK540</b>	5890681	<b>GT446</b>	5891804	<b>GD790</b>
55202800	<b>AG7310</b>	5880951	<b>FM872</b>	5888663	<b>BP130</b>	5890683	<b>DT441</b>	5891806	<b>GD671</b>
55203784	<b>TB794</b>	5880953	<b>FN402</b>	5888664	<b>BP190</b>	5890683	<b>DT442</b>	5891806	<b>GD790</b>
55203785	<b>TB787</b>	5880954	<b>CN400</b>	5888989	<b>DT410</b>	5890684	<b>DT441</b>	5891807	<b>DP013</b>
55203786	<b>TB676</b>	5880956	<b>CN400</b>	5888992	<b>GT410</b>	5890685	<b>GT441</b>	5891808	<b>GP013</b>
55205183	<b>V98006</b>	5880957	<b>GD790</b>	5889087	<b>GT400</b>	5890690	<b>DT410</b>	5891810	<b>GP070</b>
55206232	<b>AH6510</b>	5880958	<b>DD790</b>	5889095	<b>DT443</b>	5890691	<b>GT410</b>	5891811	<b>DP070</b>
55206431	<b>V98005</b>	5881110	<b>DP013</b>	5889117	<b>GT423</b>	5890692	<b>DT440</b>	5891814	<b>DP070</b>
55208213	<b>V95016</b>	5881112	<b>GP013</b>	5889118	<b>DT423</b>	5890693	<b>GT446</b>	5891818	<b>GK590</b>
55210627	<b>TB528</b>	5881122	<b>DP110</b>	5889160	<b>DT420</b>	5890694	<b>GV680</b>	5891819	<b>DR480</b>
55210628	<b>TB468</b>	5881135	<b>GP070</b>	5889162	<b>DT413</b>	5890695	<b>DV680</b>	5891825	<b>GT270</b>
55211409	<b>AH7370</b>	5881137	<b>DP070</b>	5889163	<b>DP688</b>	5890696	<b>GV680</b>	5891827	<b>DE588</b>
55211410	<b>AH7380</b>	5881157	<b>DP133</b>	5889165	<b>DT411</b>	5890699	<b>DT290</b>	5891828	<b>GJ852</b>
55211411	<b>AH7390</b>	5881172	<b>DP051</b>	5889175	<b>DP689</b>	5890703	<b>GV680</b>	5891829	<b>DR852</b>
552142160	<b>HBS465</b>	5881189	<b>DG811</b>	5889180	<b>DT420</b>	5890704	<b>DV680</b>	5891831	<b>GK590</b>
55217612	<b>TB787</b>	5881360	<b>DJ872</b>	5889186	<b>DP273</b>	5890739	<b>DS381</b>	5891832	<b>GP022</b>
55221093	<b>AH6880</b>	5881508	<b>GP021</b>	5889190	<b>GR611</b>	5890764	<b>GP282</b>	5891833	<b>DP022</b>
55221094	<b>AH6890</b>	5881510	<b>DP021</b>	5889191	<b>DR611</b>	5890825	<b>DP292</b>	5891835	<b>DP021</b>
55354237	<b>JM7103</b>	5881645	<b>GP070</b>	5889193	<b>DS570</b>	5890851	<b>DT446</b>	5891839	<b>DP292</b>
55355572	<b>V98025</b>	5881647	<b>DP070</b>	5889194	<b>GR611</b>	5890981	<b>DT270</b>	5891840	<b>GP051</b>
5542219	<b>BG540</b>	5881650	<b>DP110</b>	5889195	<b>DR611</b>	5890982	<b>GT270</b>	5891841	<b>GP051</b>
5546438	<b>GG541</b>	5881652	<b>DJ851</b>	5889259	<b>TB129</b>	5891197	<b>JM508</b>	5891850	<b>DT290</b>
55557741	<b>V98024</b>	58816747	<b>DP070</b>	5890228	<b>DT441</b>	5891199	<b>JN644</b>	5891854	<b>DR610</b>
55560688	<b>JM7102</b>	5881688	<b>DP130</b>	5890229	<b>GT441</b>	5891200	<b>LB414</b>	5891857	<b>DP688</b>
55568529	<b>EH5240</b>	5881692	<b>GK590</b>	5890312	<b>DT440</b>	5891202	<b>JN406</b>	5891859	<b>DP660</b>
5569124	<b>GG541</b>	5881923	<b>DR073</b>	5890323	<b>GT410</b>	5891203	<b>JN568</b>	5891860	<b>GP660</b>
5607430	<b>AY410</b>	5881930	<b>DP130</b>	5890455	<b>DT446</b>	5891205	<b>JA752</b>	5891862	<b>DR100</b>
5607431	<b>AY420</b>	5881945	<b>DG811</b>	5890456	<b>GT446</b>	5891206	<b>JE480</b>	5891864	<b>DP860</b>
5607474	<b>AG9580</b>	5881970	<b>GJ852</b>	5890457	<b>DT446</b>	5891207	<b>JE390</b>	5891866	<b>GV680</b>
5607512	<b>JM7102</b>	5881971	<b>DJ852</b>	5890458	<b>GT446</b>	5891208	<b>JD5155</b>	5891871	<b>GP871</b>
5607839	<b>AD5800</b>	5882026	<b>GK590</b>	5890459	<b>GT440</b>	5891213	<b>JD146</b>	5891872	<b>DP871</b>
5607840	<b>AD5810</b>	5882029	<b>DP022</b>	5890461	<b>GT446</b>	5891214	<b>JA777</b>	5891879	<b>DP292</b>
5607841	<b>AD5820</b>	5882030	<b>GP021</b>	5890467	<b>DT446</b>	5891215	<b>JA777</b>	5891881	<b>GT300</b>
5607842	<b>JM5259</b>	5882031	<b>DP021</b>	5890468	<b>GT446</b>	5891220	<b>JD021</b>	5891882	<b>DT300</b>
5607843	<b>AG7390</b>	5882038	<b>GP051</b>	5890469	<b>DT446</b>	5891222	<b>JC287</b>	5891891	<b>DT443</b>
5607845	<b>AG7400</b>	5882039	<b>DP051</b>	5890470	<b>GT446</b>	5891271	<b>BP070</b>	5891893	<b>DT420</b>
5607847	<b>AG7440</b>	5882040	<b>GP051</b>	5890471	<b>DT446</b>	5891273	<b>BP190</b>	5891895	<b>DP688</b>
5607875	<b>AD5840</b>	5882041	<b>DP051</b>	5890473	<b>DT446</b>	5891274	<b>BP130</b>	5891902	<b>GR611</b>
5607876	<b>AD5850</b>	5882049	<b>DV680</b>	5890474	<b>GT446</b>	5891275	<b>BP510</b>	5891903	<b>DR611</b>
5607877	<b>AD5860</b>	5882265	<b>DR610</b>	5890475	<b>DT446</b>	5891276	<b>BP110</b>	5891905	<b>DS570</b>
5607895	<b>AH5240</b>	5882328	<b>HT413</b>	5890476	<b>GT446</b>	5891277	<b>BP050</b>	5891906	<b>GR611</b>
5607980	<b>JM7103</b>	5882343	<b>DC027</b>	5890480	<b>DT446</b>	5891279	<b>BP110</b>	5891907	<b>DR611</b>
563145	<b>BL650</b>	5882358	<b>GV680</b>	5890481	<b>GT446</b>	5891282	<b>BE580</b>	5891909	<b>GT440</b>
5636059	<b>CAM711</b>	5882461	<b>DP688</b>	5890483	<b>GT446</b>	5891284	<b>BR090</b>	5891909	<b>GT446</b>
5636060	<b>CAM712</b>	5882567	<b>DP660</b>	5890524	<b>DP293</b>	5891287	<b>BD790</b>	5891910	<b>DT440</b>
56363063	<b>CAM654</b>	5882568	<b>GP660</b>	5890584	<b>DT440</b>	5891287M	<b>BD800</b>	5891910	<b>DT446</b>



OE		OE		OE		OE		OE	
5891911	<b>GT446</b>	5892376	<b>GP282</b>	5893774	<b>GT441</b>	60502831	<b>NA5063</b>	60548751	<b>BT380</b>
5891912	<b>DT446</b>	5892377	<b>DT400</b>	5893776	<b>GT442</b>	60502891	<b>NA5063</b>	60549557	<b>BP990</b>
5891913	<b>GT446</b>	5892378	<b>GR630</b>	5893811	<b>JC723</b>	60502913	<b>NA5064</b>	60552577	<b>BW410</b>
5891915	<b>DP293</b>	5892379	<b>DR630</b>	5893816	<b>JN426</b>	60502984	<b>JA899</b>	60558500	<b>JD018</b>
5891916	<b>GT446</b>	5892380	<b>GP861</b>	5894257	<b>DR630</b>	60503075	<b>JH565</b>	60558501	<b>JC497</b>
5891920	<b>CN400</b>	5892381	<b>DP861</b>	5894257	<b>DR631</b>	60503075	<b>JJ450</b>	60558505	<b>JD235</b>
5891921	<b>DP190</b>	5892382	<b>GP282</b>	5894379	<b>DM533</b>	60503099	<b>AN350</b>	60560701	<b>NA5066</b>
5891923	<b>DP130</b>	5892385	<b>GP011</b>	5894503	<b>DP294</b>	6050313	<b>NA5065</b>	60560702	<b>NA5066</b>
5891924	<b>DP292</b>	5892386	<b>DP011</b>	5894575	<b>BR090</b>	60503131	<b>NA5065</b>	60562594	<b>VAG96188B</b>
5891927	<b>DD790</b>	5892387	<b>FM872</b>	5894789	<b>DS381</b>	60503303	<b>JN588</b>	60562595	<b>VAG96218</b>
5891928	<b>DP190</b>	5892389	<b>GD790</b>	5894837	<b>DW320</b>	60503304	<b>JA899</b>	60563670	<b>JD224</b>
5891929	<b>DD790</b>	5892391	<b>GD790</b>	5894838	<b>GW321</b>	60504784	<b>V91615</b>	60563671	<b>JD222</b>
5891930	<b>DP293</b>	5892392	<b>DP013</b>	5894974	<b>BV940</b>	60504851	<b>JD221</b>	60564098	<b>V91308</b>
5891933	<b>DG811</b>	5892393	<b>GP013</b>	5895002	<b>GW341</b>	60504864	<b>V91438</b>	60565962	<b>BW410</b>
5891934	<b>DJ872</b>	5892394	<b>GP022</b>	5895003	<b>DW340</b>	6050500058	<b>HR816</b>	60566212	<b>NA5163</b>
5891935	<b>DP293</b>	5892395	<b>DP022</b>	5895155	<b>DW710</b>	60505485	<b>BE620</b>	60566396	<b>BW290</b>
5891936	<b>DP051</b>	5892396	<b>DP021</b>	5895156	<b>GW711</b>	60505488	<b>BE620</b>	60567018	<b>BC370</b>
5891937	<b>DJ851</b>	5892397	<b>GP051</b>	5895156	<b>GW713</b>	60506636	<b>JD223</b>	60567019	<b>AN300</b>
5891937	<b>DP293</b>	5892398	<b>GP051</b>	5895243	<b>DW720</b>	60507000	<b>JE696</b>	605670190	<b>AN300</b>
5891940	<b>DT420</b>	5892400	<b>DR610</b>	5895244	<b>GW724</b>	60507020	<b>JE696</b>	60567020	<b>BH850</b>
5891943	<b>DG811</b>	5892404	<b>DS570</b>	5895398	<b>DW281</b>	60507102	<b>NA5066</b>	60567604	<b>NA5163</b>
5891945	<b>DV680</b>	5892405	<b>GR611</b>	5895398	<b>DW282</b>	60507107	<b>NA5066</b>	60568808	<b>JN814</b>
5891949	<b>DP051</b>	5892406	<b>DR611</b>	5895399	<b>GW281</b>	605071070	<b>NA5066</b>	60568809	<b>JN813</b>
5891950	<b>DP051</b>	5892407	<b>GT260</b>	5895399	<b>GW282</b>	60507155	<b>BK570</b>	60570141	<b>JD221</b>
5891953	<b>DT413</b>	5892408	<b>DT260</b>	5895540	<b>DT448</b>	60507156	<b>BP260</b>	60570141	<b>JH565</b>
5891955	<b>DP292</b>	5892409	<b>GT400</b>	5895644	<b>DX040</b>	60507157	<b>BK580</b>	60570141	<b>JJ450</b>
5891957	<b>DT420</b>	5892410	<b>GR620</b>	5895645	<b>GX041</b>	605071720	<b>JC928</b>	60570142	<b>JJ450</b>
5891972	<b>DE588</b>	5892411	<b>DR620</b>	5895663	<b>DX030</b>	60507189	<b>V91437</b>	60570351	<b>BT390</b>
5891973	<b>DT411</b>	5892412	<b>GP871</b>	5895664	<b>GX030</b>	60507190	<b>V91438</b>	60570352	<b>BT380</b>
5891980	<b>GT410</b>	5892413	<b>GR611</b>	5921087	<b>BP290</b>	60507402	<b>NA5163</b>	60570617	<b>NJ951</b>
5891981	<b>DP689</b>	5892414	<b>DR611</b>	5930415	<b>HR596</b>	60507557	<b>HR800</b>	60572412	<b>VAG96184</b>
5891983	<b>DP689</b>	5892415	<b>GT270</b>	5936189	<b>BK540</b>	60507652	<b>JD025</b>	60572415	<b>VAG96197B</b>
5891987	<b>DT413</b>	5892416	<b>DT270</b>	5941935	<b>BP130</b>	60507653	<b>JF123</b>	60572819	<b>HBS108</b>
5891989	<b>DT410</b>	5892419	<b>DT290</b>	5942273	<b>FOL126</b>	60512669	<b>NA5066</b>	60572823	<b>HBS108</b>
5891990	<b>GT410</b>	5892420	<b>GT300</b>	5942727	<b>V91288</b>	60512948	<b>JN808</b>	60573536	<b>JD587</b>
5891992	<b>GT400</b>	5892421	<b>DT300</b>	5942728	<b>V91289</b>	60512949	<b>JN807</b>	60579200	<b>VAG96268</b>
5892007	<b>DT440</b>	5892422	<b>GV680</b>	5943565	<b>BK540</b>	60513135	<b>JJ515</b>	60579202	<b>VAG96260B</b>
5892007	<b>DT446</b>	5892423	<b>DV680</b>	5945253	<b>JN426</b>	60513181	<b>JD222</b>	60581645	<b>AN350</b>
5892008	<b>GT446</b>	5892424	<b>GV680</b>	5950297	<b>CAM641</b>	60513311	<b>JN812</b>	60581846	<b>AN350</b>
5892009	<b>DT440</b>	5892427	<b>DT290</b>	5951664	<b>BP290</b>	60513316	<b>JN812</b>	60582738	<b>V94210</b>
5892009	<b>DT446</b>	5892431	<b>DP273</b>	5951675	<b>BK540</b>	60513350	<b>KV086</b>	60582739	<b>V94211</b>
5892010	<b>GT446</b>	5892434	<b>DE588</b>	5951683	<b>BJ850</b>	60513358	<b>KV086</b>	60583742	<b>JC928</b>
5892011	<b>DT440</b>	5892436	<b>DP273</b>	5952256	<b>BK540</b>	60513869	<b>JD586</b>	60584488	<b>AY630</b>
5892011	<b>DT446</b>	5892438	<b>DP273</b>	5953041	<b>V91394</b>	60513941	<b>FOL130</b>	60586217	<b>HL701</b>
5892012	<b>GT446</b>	5892439	<b>GR100</b>	5953970	<b>BJ850</b>	60514910	<b>BP990</b>	60589234	<b>BK570</b>
5892013	<b>DT440</b>	5892440	<b>DR100</b>	5959226	<b>JJ298</b>	60515780	<b>NA5066</b>	60591809	<b>BP990</b>
5892014	<b>GT446</b>	5892441	<b>GJ872</b>	5962711	<b>AC5140</b>	60515781	<b>NA5066</b>	60591810	<b>BE620</b>
5892015	<b>DT446</b>	5892672	<b>DT441</b>	5962712	<b>BT230</b>	60515793	<b>JA829</b>	60591811	<b>BE620</b>
5892016	<b>GT446</b>	5892673	<b>GT441</b>	5962713	<b>BT240</b>	60521575	<b>V90388</b>	60591812	<b>BP990</b>
5892341	<b>DT440</b>	5892678	<b>DT752</b>	5962714	<b>AC5140</b>	605226920	<b>JN581</b>	60596115	<b>BW710</b>
5892341	<b>DT446</b>	5892690	<b>DW260</b>	5962715	<b>BT230</b>	60523	<b>JN811</b>	60596116	<b>BW720</b>
5892342	<b>GT446</b>	5893002	<b>DT440</b>	5962716	<b>BT240</b>	60523241	<b>BH850</b>	60602071	<b>AY640</b>
5892343	<b>GT423</b>	5893002	<b>DT449</b>	5966008	<b>JN645</b>	60523245	<b>BC370</b>	60603436	<b>NA5069</b>
5892344	<b>DT423</b>	5893003	<b>GT440</b>	596842	<b>BM530</b>	60525029	<b>JD014</b>	60604889	<b>TB703</b>
5892345	<b>DT446</b>	5893004	<b>DT446</b>	5970285	<b>BP280</b>	60525316	<b>JN811</b>	6060500058	<b>HR5062</b>
5892347	<b>DT420</b>	5893005	<b>GT446</b>	5972336	<b>JA777</b>	60525336	<b>V91622</b>	60605739	<b>VAG96262</b>
5892349	<b>DT446</b>	5893177	<b>DP292</b>	5973129	<b>V91762</b>	60525337	<b>V91623</b>	60605898	<b>BK580</b>
5892350	<b>GT446</b>	5893282	<b>DR632</b>	5975341	<b>V91636</b>	60525822	<b>BT340</b>	60605899	<b>BP260</b>
5892351	<b>GT441</b>	5893329	<b>DT440</b>	5980056	<b>JN568</b>	60534406	<b>HR815</b>	60605900	<b>BK570</b>
5892352	<b>DT441</b>	5893329	<b>DT449</b>	5984010	<b>BT410</b>	60534424	<b>JC497</b>	60607218	<b>HL700</b>
5892353	<b>DT441</b>	5893330	<b>GT440</b>	5984039	<b>BP280</b>	60534664	<b>JN806</b>	60607219	<b>HL700</b>
5892353	<b>DT449</b>	5893340	<b>DT441</b>	5984091	<b>BG820</b>	60534664	<b>JP004</b>	60607745	<b>AY610</b>
5892354	<b>GT441</b>	5893400	<b>DT448</b>	5984092	<b>BG830</b>	60534705	<b>JD018</b>	60608122	<b>AY620</b>
5892364	<b>GP070</b>	5893560	<b>GT442</b>	5984255	<b>FOL171</b>	60535949	<b>HR801</b>	60608894	<b>AY500</b>
5892365	<b>DP070</b>	5893658	<b>GP285</b>	5990532	<b>V91767</b>	60540325	<b>V91630</b>	60608894	<b>BW720</b>
5892367	<b>GJ852</b>	5893692	<b>GT401</b>	5990533	<b>V91392</b>	60540326	<b>V91629</b>	60608895	<b>BW710</b>
5892368	<b>DJ852</b>	5893693	<b>DT401</b>	5994226	<b>JN667</b>	60542965	<b>JN810</b>	60609156	<b>BW410</b>
5892369	<b>DP660</b>	5893767	<b>DT441</b>	5997543	<b>BP300</b>	60544360	<b>KV102</b>	60609159	<b>JN940</b>
5892370	<b>GP660</b>	5893767	<b>DT447</b>	5999103	<b>BP290</b>	60546397	<b>JD565</b>	60609978	<b>JP070</b>
5892371	<b>DP860</b>	5893768	<b>GT447</b>	602828510	<b>BW410</b>	60548448	<b>BT340</b>	60609979	<b>JP071</b>
5892374	<b>DP871</b>	5893773	<b>DT441</b>	6040500058	<b>HR791</b>	60548495	<b>HR800</b>	60610985	<b>NA5163</b>

# OE INTERCHANGE

OE-Vergleichsliste • Intercambio con OE  
Références croisées 1ère Monte

OE	OE	OE	OE	OE	OE	OE	OE	OE	OE
60611305	<b>TB532</b>	60750652	<b>CN353</b>	60778168	<b>FF24R</b>	60812382	<b>TB732</b>	6165498	<b>NA5177</b>
60611531	<b>JD273</b>	60755016	<b>BE620</b>	60778171	<b>GC374</b>	60812490	<b>BW720</b>	6165499	<b>NB959</b>
60611545	<b>JD466</b>	60755077	<b>GT340</b>	60778172	<b>GC374</b>	60812654	<b>FOL145</b>	6165500	<b>NB959</b>
60616864	<b>BY390</b>	60777052	<b>DC372</b>	60778173	<b>GC374</b>	60812729	<b>JD273</b>	6176471	<b>NB959</b>
60616867	<b>HBS262</b>	60777054	<b>DT350</b>	60778175	<b>DE623</b>	60812981	<b>V91932</b>	6185177	<b>BT520</b>
60618726	<b>TB532</b>	60777057	<b>DW260</b>	60778179	<b>DC372</b>	60812982	<b>V91931</b>	6185178	<b>BT520</b>
60619673	<b>BY390</b>	60777058	<b>GT350</b>	60778181	<b>DH854</b>	60813045	<b>JC738</b>	6185181	<b>BT510</b>
60620887	<b>TB732</b>	60777059	<b>GC374</b>	60778182	<b>DC372</b>	60813203	<b>TB532</b>	6185182	<b>BT510</b>
60621381	<b>JD466</b>	60777062	<b>DH854</b>	60778234	<b>GK572</b>	60813241	<b>AY640</b>	636836	<b>NC006</b>
60623146	<b>FOL130</b>	60777105	<b>GT340</b>	60778235	<b>DK570</b>	60813258	<b>JP071</b>	636838	<b>NC006</b>
60625128	<b>TB528</b>	60777118	<b>DE623</b>	60778236	<b>GK570</b>	60813259	<b>JP070</b>	636841	<b>NC006</b>
60625130	<b>TB468</b>	60777155	<b>GW280</b>	60778236	<b>GK572</b>	60813598	<b>VAG96124</b>	638196	<b>NA5069</b>
60630269	<b>JD224</b>	60777156	<b>DW280</b>	60778304	<b>DW260</b>	60813598	<b>VAG96203</b>	638199	<b>NA5108</b>
60654310	<b>NF888</b>	60777247	<b>DW260</b>	60778304	<b>DW261</b>	60813744	<b>JD468</b>	640001	<b>FOL129</b>
60655592	<b>JM5002</b>	60777317	<b>DC372</b>	60778459	<b>GK572</b>	60813760	<b>BT380</b>	640039	<b>FOL187</b>
60655830	<b>NF888</b>	60777319	<b>DH854</b>	60778648	<b>DT443</b>	60814219	<b>AC5140</b>	640051	<b>FOL38</b>
60656340	<b>TB528</b>	60777321	<b>DT350</b>	60778648	<b>DT448</b>	60814219	<b>BV680</b>	640059	<b>FOL38</b>
60656342	<b>TB468</b>	60777615	<b>DW410</b>	60778765	<b>DT340</b>	60814220	<b>AC5150</b>	641072	<b>V95015</b>
60659190	<b>AA5420</b>	60777616	<b>GW410</b>	60778829	<b>DW260</b>	60814221	<b>AC5180</b>	641073	<b>V94588</b>
60659746	<b>JD466</b>	60777695	<b>JD221</b>	60778829	<b>DW261</b>	60814222	<b>AC5160</b>	641074	<b>V94588</b>
60659747	<b>JD271</b>	60777697	<b>JE696</b>	60778968	<b>GK573</b>	60814319	<b>TB468</b>	641075	<b>V94588</b>
60659758	<b>AA5420</b>	60777724	<b>DT443</b>	60778969	<b>GK573</b>	60814374	<b>NF888</b>	6420500080	<b>FOL190</b>
60664260	<b>JA5007</b>	60777747	<b>JN588</b>	607960	<b>HBS055</b>	60814599	<b>AY520</b>	642500	<b>PA5025</b>
60664642	<b>AA5420</b>	60777756	<b>JA840</b>	60800018	<b>FOL104</b>	60814600	<b>AY530</b>	642504	<b>HR5088</b>
60665425	<b>HBS262</b>	60777771	<b>CN306</b>	60805104	<b>JC662</b>	60814601	<b>AY540</b>	64611495	<b>FOL100</b>
60667293	<b>JM5024</b>	60777775	<b>CN306</b>	60805718	<b>NA5053</b>	60814602	<b>JP063</b>	6461884	<b>BW350</b>
60667294	<b>JM5023</b>	60777776	<b>CN306</b>	60805835	<b>HR800</b>	60814603	<b>TB639</b>	646299	<b>NA5174</b>
60667495	<b>AA5420</b>	60777780	<b>CN306</b>	60806695	<b>BT440</b>	60814604	<b>V94065</b>	646910	<b>NA5223</b>
60670506	<b>TB468</b>	60777781	<b>CN306</b>	60807143	<b>JD153</b>	60814605	<b>V94064</b>	6535949	<b>HR801</b>
60671874	<b>AD5870</b>	60777790	<b>DT420</b>	60807260	<b>TB579</b>	60814724	<b>CY550</b>	6606019	<b>CH5242</b>
60672888	<b>TB528</b>	60777792	<b>DT420</b>	60807357	<b>HBS092</b>	60814725	<b>FY550</b>	6650500025	<b>FOL190</b>
60674496	<b>V94591</b>	60777795	<b>GT340</b>	60807621	<b>HBS093</b>	60814952	<b>JP064</b>	6650501025	<b>FOL190</b>
60674528	<b>TB532</b>	60777797	<b>GT350</b>	60808083	<b>NA5163</b>	60814966	<b>AY550</b>	6663814	<b>NB959</b>
60674888	<b>TB528</b>	60777939	<b>DK570</b>	60808412	<b>JN808</b>	60814967	<b>AY560</b>	6680500180	<b>FOL190</b>
60674890	<b>TB468</b>	60777939	<b>GK570</b>	60808630	<b>JN807</b>	60814968	<b>AY570</b>	67332295	<b>HBS033</b>
60677983	<b>AD5950</b>	60777952	<b>DC372</b>	60808640	<b>BR680</b>	60814969	<b>CY520</b>	6804674	<b>FOL123</b>
60700088	<b>JP004</b>	60777953	<b>DH854</b>	60808640	<b>BV680</b>	60814970	<b>FY520</b>	6945586	<b>FOL123</b>
60709171	<b>AF240</b>	60777955	<b>CN306</b>	60808641	<b>BV690</b>	60815726	<b>JC738</b>	6957756	<b>FOL151</b>
60711523	<b>AN300</b>	60777957	<b>DH854</b>	60808642	<b>BW980</b>	60816179	<b>JA5035</b>	6C106051AB	<b>AH6390</b>
60713115	<b>FF24R</b>	60777958	<b>DC372</b>	60808659	<b>JN459</b>	60816183	<b>JA5036</b>	6C106051BB	<b>AH6400</b>
60713116	<b>CF24N</b>	60777959	<b>DH854</b>	60809415	<b>TB474</b>	60816184	<b>FY550</b>	6C106051CB	<b>AH6410</b>
60714997	<b>BC370</b>	60777962	<b>GC374</b>	60809643	<b>BV680</b>	60816185	<b>CY550</b>	701349529	<b>HR300</b>
607208	<b>HBS416</b>	60777967	<b>CN353</b>	60809644	<b>BV690</b>	60816186	<b>FY520</b>	702219	<b>BL650</b>
60722008	<b>FF24R</b>	60777968	<b>DE622</b>	60809645	<b>BW980</b>	60816187	<b>CY520</b>	7029357	<b>BK540</b>
60722057	<b>FF24R</b>	60777970	<b>DE622</b>	60809849	<b>NA5053</b>	60816190	<b>AA5420</b>	70HM6266AA	<b>TB192</b>
60723677	<b>BC370</b>	60777971	<b>CN353</b>	60810438	<b>VAG96263</b>	60816233	<b>AA5561</b>	70HM6268A1A	<b>TB192</b>
60723678	<b>BC370</b>	60777978	<b>GC374</b>	60810586	<b>BT390</b>	60816234	<b>AA5571</b>	70HM6268A2A	<b>TB192</b>
60724725	<b>DC372</b>	60777982	<b>DE623</b>	60810669	<b>HR800</b>	60816235	<b>AA5581</b>	70HM6268AA	<b>TB192</b>
60724921	<b>BH850</b>	60777984	<b>GW280</b>	60811086	<b>VAG96123</b>	60816385	<b>JM5028</b>	71711023	<b>DW721</b>
60725751	<b>DH854</b>	60777986	<b>DW260</b>	60811086	<b>VAG96146</b>	60816423	<b>AA5420</b>	71711024	<b>GW721</b>
60727820	<b>CN306</b>	60777995	<b>DC372</b>	60811087	<b>VAG96229</b>	60816451	<b>FA5560</b>	71711143	<b>GY411</b>
60728351	<b>DH854</b>	60777997	<b>DH854</b>	60811089	<b>VAG96145</b>	60816452	<b>FA5560</b>	71711144	<b>DY410</b>
60730162	<b>DC372</b>	60777999	<b>DT350</b>	60811090	<b>VAG96230</b>	60816453	<b>CA5560</b>	71711279	<b>DW711</b>
60732778	<b>DK570</b>	60778001	<b>DW280</b>	60811136	<b>TB468</b>	60816562	<b>AA5780</b>	71711280	<b>GW711</b>
60732780	<b>DK570</b>	60778051	<b>DR040</b>	60811153	<b>V91933</b>	60816563	<b>AA5790</b>	71711493	<b>DW322</b>
60732780	<b>GK570</b>	60778115	<b>GW281</b>	60811154	<b>V91934</b>	60816564	<b>AA5800</b>	71711517	<b>CY320</b>
60733096	<b>GK570</b>	60778116	<b>DW280</b>	60811160	<b>FOL145</b>	60816595	<b>CA5780</b>	71711518	<b>FY320</b>
60733352	<b>JD018</b>	60778116	<b>DW281</b>	60811349	<b>JD271</b>	60816719	<b>TB532</b>	71711735	<b>DY390</b>
60734690	<b>CN306</b>	60778151	<b>FF24R</b>	60811572	<b>HR800</b>	6134416	<b>JN594</b>	71711736	<b>GY390</b>
60735201	<b>DH854</b>	60778152	<b>GC374</b>	60811872	<b>HR800</b>	6139910	<b>TB192</b>	71711936	<b>DY382</b>
60735218	<b>BH850</b>	60778153	<b>DC372</b>	60811964	<b>NA5187</b>	614811	<b>NB698</b>	71711967	<b>CY640</b>
60737369	<b>VAG96267</b>	60778154	<b>DH854</b>	60812037	<b>NA5163</b>	614819	<b>NB806</b>	71711968	<b>FY640</b>
60741414	<b>DT350</b>	60778156	<b>DH854</b>	60812121	<b>AC5140</b>	614820	<b>NB698</b>	71712360	<b>CY520</b>
60743551	<b>DW260</b>	60778157	<b>DC372</b>	60812121	<b>BV680</b>	614821	<b>NB698</b>	71712361	<b>FY520</b>
60743841	<b>GC374</b>	60778158	<b>DC373</b>	60812122	<b>AC5150</b>	614827	<b>NB806</b>	71712434	<b>CY620</b>
607493	<b>AY400</b>	60778158	<b>DH854</b>	60812122	<b>BV690</b>	614829	<b>NB806</b>	71712435	<b>FY620</b>
60750004	<b>DT420</b>	60778159	<b>GC374</b>	60812123	<b>AC5180</b>	614830	<b>NB698</b>	71712630	<b>AA5550</b>
60750006	<b>DT420</b>	60778161	<b>CN353</b>	60812123	<b>BV700</b>	614860	<b>NA5230</b>	71712830	<b>FY550</b>
60750222	<b>VAG96261</b>	60778162	<b>DE622</b>	60812124	<b>AC5160</b>	6155561	<b>BT520</b>	71712831	<b>CY550</b>
60750597	<b>DE622</b>	60778164	<b>DE622</b>	60812124	<b>BW980</b>	6155565	<b>BT510</b>	71712889	<b>CY610</b>
60750651	<b>DE622</b>	60778165	<b>CN353</b>	60812344	<b>TB468</b>	6155579	<b>NA5177</b>	71712890	<b>FY610</b>

OE		OE		OE		OE		OE	
71712891	AA5520	71719751	CE5180	71744288	CD5820	7553561	NB815	7625273	JD021
71713031	DX030	71719779	EA5420	71744288	FD5820	7553616	HR599	7625500	BT410
71713032	GX030	71728337	GX410	71744388	V98025	7553616	HR800	7625504	JC662
71713041	NF888	71728339	GX392	71744395	AH5240	7553636	HR596	7628414	JD013
71713629	DY391	71728825	EV684	71744413	JD5982	7553637	HR805	7628850	NA5070
71713630	GY391	71728826	EB5150	71746353	TBK314	7554279	NB815	7630180	BR680
71713631	DW722	71728827	EV670	71747638	CG7310	7554363	JJ453	7630181	BV690
71713632	GW722	71728831	EA5780	71749474	TB660	7554701	TB129	7630182	BR700
71713633	DW712	71728839	EE5180	71753156	TB787	7554851	JP049	7630182	BV700
71713634	GW712	71728880	EE5242	71753175	BT230	7554963	JJ471	7631023	BP520
71713675	DW322	71729223	JA5005	73001262	NP068	7555140	BR620	7631024	BP030
71713695	DX391	71729498	ED5800	7300877	JC055	7564332	BR630	7636480	JD022
71713696	GX410	71730147	EA5420	7301198	NP067	7564650	BV680	7637103	BP860
71713723	CY640	71730148	EA5420	7301262	NP068	7564651	BT230	7638954	JC662
71713724	FY640	71730149	ED5960	7301481	JN462	7564651	BV690	7640074	BP300
71713861	AY470	71730213	EE5181	7301683	JJ100	7564652	BT240	7640074	BT400
71713924	AY500	71730214	CD5840	7301820	V91292	7564652	BV700	7640783	BP660
71713956	AY480	71730404	EE5181	7301821	V91293	7565472	VAG96210	7640784	BP280
71713987	GY680	71731639	TB639	7302157	V91294	7574742	V91638	7641616	BJ860
71714093	AY510	71732900	CE5181	7302293	JN594	7574881	V91307	7641616	BJ880
71714142	CY610	71734258	ED5910	7302473	BR070	7574959	BT860	7644534	BR620
71714142	CY611	71734259	CD5910	7302582	JJ317	7574967	JN643	7645030	BJ850
71714143	FY610	71736222	CD5970	7302624	JN585	7575382	JN928	7646223	JD148
71714143	FY611	71736243	CE5181	7303076	JC706	7575386	JD153	7646248	JJ413
71714940	DW723	71736315	CG7381	7303161	DR073	7575665	BP860	7646725	TB660
71714941	GW723	71736714	TBK094	7303309	V91400	7579741	BP280	7647596	JJ398
71715110	BV940	71736715	TBK089	7303596	BR090	7579742	BP280	7648057	BV670
71715130	AE5550	71736717	TBK313	732101M1	V3251	7580221	BP860	7648248	BP520
71715448	AY460	71736718	TBK277	73500063	JM5259	7581344	HR599	7648249	BP520
71715698	DZ790	71736719	TBK314	73503122	FOL106	7581344	HR646	7648251	HBS279
71715698	GZ790	71736720	TBK037	7433517893	HR800	7581344	HR800	7649849	JJ449
71715699	DZ790	71736725	TBK345	7500713	HR599	7581743	HBS052	7650355	HR599
71716050	FA5560	71736726	TBK283	7500713	HR646	7582158	HR599	7650612	HBS097
71716051	CA5560	71736727	TBK356	7500716	HR816	7588577	V91321	7650916	V91936
71716583	JA5005	71736729	TBK207	75134	DE622	7589788	BP110	7651738	LB414
71716584	JA5005	71736795	TBK104	7533476	BP520	7596552	BT400	7651739	JN644
71716585	JA5005	71736913	ED5800	7533479	BP520	7596614	JN667	7653650	HBS095
71716684	JA5010	71737120	GR620	7533622	NB825	7596714	JC738	7657305	JN804
71716868	DV672	71737128	DR620	7537664	JC660	7596968	BP660	7659062	TB474
71716869	GP286	71737153	CD5960	7537667	V91287	7597077	JD019	7659102	BV680
71716870	DY383	71737163	CY320	7537668	V91286	7597077	JE744	7659103	BV690
71716871	GY383	71737164	FY320	7537684	BP660	7597080	V91305	7659104	BV700
71717683	CA5420	71739214	JD5868	7539929	BP030	7597553	BT300	7659618	JD151
71717685	CA5420	71739686	V98004	7540289	BT420	7597555	BT320	7660565	JN643
71717833	FY550	71739873	TB741	7540290	BT410	7597565	V91659	7660759	JN803
71717834	CY550	71739918	TB320	7540379	BT440	7597566	V91658	7660771	FOL119
71717836	CY520	71739919	TB175	7541092	JN587	7597832	JN809	7660966	BT440
71717900	CA5421	71739922	TB419	7541250	BT860	7604263	BT410	7662197	BT410
71717901	CA5421	71739933	CE5180	7541251	JN666	7604264	BT420	7662227	V91289
71718011	GX392	71739945	CG6220	7541252	JC723	7604403	BR620	7663366	JJ453
71718012	DX392	71739971	CA5561	7541776	BJ860	7604404	BR630	7665093	JD067
71718045	CA5590	71740083	EG7390	7541777	BJ870	7609752	JC738	7666227	V91289
71718129	FA5560	71740084	EG7450	7541778	BJ880	7609772	V91300	7666228	V91288
71718130	CA5560	71740296	CE5241	75452930	JB869	7610498	JD013	7666858	BR620
71718142	CB5150	71740655	CG7380	7545293080	JB869	7611679	VAG96181B	7667675	BR630
71718333	CA5780	71740678	JM7099	7545293080A	JB869	7613726	HR5064	7668195	JD151
71718365	NF888	71740681	NA5057	7545293080B	JB869	7614999	TB579	7669581	JF145
71718389	GP286	71740961	CG7410	7545947	BP280	7616679	BT860	7669585	JJ440
71718390	DP286	71740962	EG7410	7546875	JN644	7616992	VAG96199	7672168	BT410
71718658	CA5560	71740964	CG7390	7546876	JN644	7616998	VAG92496	7676324	JN948
71718659	FA5560	71741112	V98001	7546877	JN644	7617500	V91306	7677631	JC738
71718738	LK5001	71741113	V98002	7547158	V91291	7621070	JD022	7678282	JF150
71718831	HA5005	71741374	CE5242	7547400	V91765	7621071	JD022	7681975	V94795
71718852	CD5970	71741916x10	HBS497	7547597	CAM719	7624874	BR680	7683521	V94793
71718853	FD5970	71741918	AG8180	7548076	TB579	7624874	BV680	7683522	V94795
71719643	TB608	71744285	CD5810	7552551	BT410	7624875	BV700	7684064	JN948
71719648	TB468	71744285	FD5810	7552552	BT420	7624876	BR700	7688249	BP520
71719649	TB528	71744286	ED5810	7553004	V91655	7624876	BV690	7688450	JN667
71719651	TB639	71744286	FD5810	75530731	JN426	7624876	BV700	7694363	BT260
71719652	TB649	71744287	ED5820	7553073180	JN426	7624876	BW980	7694624	BT260
71719654	CE5181	71744287	FD5820	7553561	NB814	7625272	JD021	7696197	HBS052



OE	OE	OE	OE	OE	OE	OE	OE		
93190885	<b>CH5242</b>	9464640380	<b>TB742</b>	96136745	<b>HBS125</b>	9635967180	<b>AC5012</b>	97533264	<b>V91273</b>
93192070	<b>JD5993</b>	9467538580	<b>TBK106</b>	96137360	<b>V91145</b>	9635967280	<b>AC5020</b>	97533266	<b>V91271</b>
93501128	<b>NF841</b>	9467544580	<b>TBK355</b>	96141369	<b>TB346</b>	9635967380	<b>AC5032</b>	9790018200	<b>DM530</b>
93501444	<b>JN544</b>	9467565880	<b>TB724</b>	96141369	<b>TB419</b>	9635967480	<b>AC5040</b>	9790018300	<b>DM530</b>
9350144480	<b>JN544</b>	95100257	<b>HR599</b>	96142525	<b>TB175</b>	9635967580	<b>AC5052</b>	98410475	<b>AB5100</b>
93501573	<b>CAM354</b>	9543455	<b>NA5069</b>	96142525	<b>TB560</b>	9636017380	<b>AD5300</b>	98410476	<b>AY590</b>
93501758	<b>FOL73</b>	95493121	<b>BG540</b>	96142597	<b>TB175</b>	9636179280	<b>AH5050</b>	98418161	<b>V91940</b>
93502226	<b>JJ283</b>	95494183	<b>BG540</b>	96142597	<b>TB560</b>	9636180080	<b>AH5070</b>	98419390	<b>TB368</b>
93510091	<b>TB175</b>	95512889	<b>NA5057</b>	96147032	<b>V91970</b>	9636848480	<b>FOL190</b>	98424150	<b>JN585</b>
93510091	<b>TB560</b>	95542219	<b>BG540</b>	961494980	<b>NA5191</b>	9637053980	<b>TB683</b>	98424150	<b>JN969</b>
93510179	<b>CAM354</b>	95569123	<b>DG542</b>	9614972480	<b>BM530</b>	9637122980	<b>TB720</b>	98425767	<b>JC054</b>
93510415	<b>V91144</b>	95569124	<b>GG541</b>	9616067680	<b>BV140</b>	9637123580	<b>TB720</b>	98427672	<b>CAM718</b>
93510773	<b>V91145</b>	95591804	<b>JC415</b>	96160677	<b>BV140</b>	9637240580	<b>TB683</b>	98427674	<b>CAM681</b>
93510774	<b>V91145</b>	9559180480	<b>JC415</b>	96182679	<b>TB727</b>	9637513980	<b>TB678</b>	98427939	<b>JJ515</b>
938M6500A1D	<b>FOL123</b>	95602513	<b>DJ720</b>	9618337580	<b>TB727</b>	96375140	<b>TB678</b>	98427996	<b>NB946</b>
938M6500A1E	<b>FOL123</b>	95602514	<b>GJ720</b>	9618603280	<b>BG540</b>	9637514080	<b>TB678</b>	98427998	<b>NP067</b>
938M6500A2D	<b>FOL123</b>	9561800	<b>HR569</b>	96190676	<b>BY310</b>	9637858380	<b>FOL190</b>	98428409	<b>NP068</b>
938M6500A2E	<b>FOL123</b>	95639605	<b>TB346</b>	9619100480	<b>BY310</b>	9637914580	<b>TB724</b>	98432857	<b>LS856</b>
938M6500A2F	<b>FOL123</b>	95639605	<b>TB419</b>	9619659980	<b>BY310</b>	9637914680	<b>TB724</b>	98432884	<b>LS857</b>
938M6500B2A	<b>FOL123</b>	95644580	<b>DJ720</b>	9619659980	<b>BY320</b>	9638075480	<b>FOL115</b>	98434020	<b>JC055</b>
9400127459	<b>NA5192</b>	95644580	<b>GJ720</b>	96197793	<b>TB346</b>	9640296380	<b>FOL163</b>	98436545	<b>NF853</b>
9400197139	<b>GM533</b>	95644581	<b>DJ720</b>	96197793	<b>TB419</b>	9640669280	<b>TB720</b>	98450599	<b>AB5110</b>
9400197149	<b>DM530</b>	95650948	<b>DS820</b>	9619779380	<b>TB346</b>	9640810680	<b>TB720</b>	98448817	<b>AB5110</b>
9400197169	<b>DM533</b>	95650949	<b>DS820</b>	9619779380	<b>TB419</b>	9640828680	<b>TB742</b>	98451055	<b>NP068</b>
9400197369	<b>GJ720</b>	95654054	<b>DV150</b>	96197874	<b>TB479</b>	96411866	<b>JN808</b>	98454039	<b>NP067</b>
9400197379	<b>DJ720</b>	95655248	<b>DV150</b>	96200344	<b>TB479</b>	96411875	<b>JN812</b>	98454041	<b>NP067</b>
9400197849	<b>DM533</b>	95655249	<b>DV150</b>	9620571080	<b>JD5972</b>	96411878	<b>JJ451</b>	98454045	<b>NP067</b>
9400209239	<b>BM530</b>	9566937980	<b>DS820</b>	9621469980	<b>JC759</b>	96411879	<b>JJ452</b>	98454045	<b>NP068</b>
9400807289	<b>NA5035</b>	9567221180	<b>DJ720</b>	9621917180	<b>BX930</b>	9643596780	<b>AD5150</b>	98454057	<b>NF853</b>
9400816190	<b>TB683</b>	9567223980	<b>EL890</b>	9621917280	<b>BX940</b>	9643597080	<b>AD5130</b>	98461673	<b>NF885</b>
94008165	<b>TB175</b>	9567223980	<b>GJ720</b>	9621917380	<b>BX950</b>	9643597180	<b>AD5140</b>	98468338	<b>V91939</b>
94008165	<b>TB560</b>	9567224080	<b>JC991</b>	9621917480	<b>BX960</b>	9643597380	<b>AD5160</b>	98471766	<b>BR070</b>
9400816549	<b>TB320</b>	9569757780	<b>JD6023</b>	96223131	<b>TB631</b>	9643597480	<b>AD5170</b>	98472291	<b>JN956</b>
9400816589	<b>TB175</b>	95VW65718A	<b>HR599</b>	9623068080	<b>BX880</b>	9645717480	<b>TB724</b>	98480250	<b>BE580</b>
9400816589	<b>TB560</b>	96003672	<b>V91144</b>	9623068180	<b>BX890</b>	9645717580	<b>TB724</b>	98482291	<b>AY310</b>
9400816939	<b>TB631</b>	96005391	<b>V91144</b>	9623068280	<b>BX900</b>	9645863080	<b>NA5191</b>	98482940	<b>NF853</b>
9400816969	<b>TB632</b>	96005977	<b>HBS038</b>	9623068380	<b>BX910</b>	9645863280	<b>NA5192</b>	98492142	<b>EW091</b>
9400816989	<b>TB479</b>	96007817	<b>V94169</b>	9623068480	<b>BX920</b>	9647610080	<b>TB683</b>	98492149	<b>EW091</b>
9400831069	<b>TB346</b>	96008334	<b>V94169</b>	9624835280	<b>CAM679</b>	9648968580	<b>TB724</b>	98492150	<b>DS381</b>
9400831069	<b>TB419</b>	96008902	<b>BL650</b>	9624851880	<b>AA5830</b>	9651513280	<b>AH5040</b>	98492152	<b>DR073</b>
9400831119	<b>TB320</b>	9600897480	<b>BR510</b>	9624851980	<b>AA5840</b>	9652803180	<b>AD5701</b>	98492580	<b>AY290</b>
9400831119	<b>TBK035</b>	96010048	<b>JC759</b>	9624852080	<b>AA5850</b>	9653226680	<b>TB720</b>	98492581	<b>AY300</b>
9400831279	<b>TBK020</b>	9601004880	<b>JC759</b>	9624852180	<b>AA5860</b>	9653226280	<b>TB720</b>	98498291	<b>AY310</b>
9400831349	<b>TBK344</b>	9601136380	<b>V91144</b>	9624852280	<b>AA5870</b>	9659795080	<b>TB724</b>	986955	<b>JH310</b>
9400831409	<b>TBK106</b>	96014480	<b>NF817</b>	96252153	<b>TB631</b>	9660035980	<b>V98028</b>	986984	<b>JA752</b>
9400831489	<b>TBK113</b>	96020124	<b>HR599</b>	96261574	<b>TB632</b>	9660534980	<b>AH6400</b>	987057	<b>KG393</b>
9400831529	<b>TBK035</b>	96020124	<b>HR800</b>	9626157480	<b>TB632</b>	9660535080	<b>AH6410</b>	988803	<b>JE480</b>
9400831559	<b>TBK279</b>	96027105	<b>FOL126</b>	9627184380	<b>V94490</b>	9660640080	<b>V98029</b>	99310411101	<b>HR805</b>
9400831589	<b>TBK105</b>	96028464	<b>JC415</b>	9628139180	<b>BX980</b>	96700311	<b>V91300</b>	99425767	<b>JC054</b>
9400831609	<b>TBK303</b>	9603104288	<b>CAM373</b>	96289433	<b>V94175</b>	9676718180	<b>V95083</b>	9942588	<b>JP069</b>
9400831629	<b>TBK106</b>	96034899	<b>JD230</b>	96290822	<b>TB632</b>	9677399780	<b>AD5701</b>	99430005	<b>BX390</b>
9400831789	<b>TBK106</b>	96042653	<b>JJ283</b>	9629082280	<b>TB632</b>	9682002980	<b>AH7290</b>	99430032	<b>TB558</b>
9400831829	<b>TBK106</b>	96049648	<b>TB320</b>	96298611	<b>V94176</b>	9682013280	<b>AH7300</b>	99432353	<b>BX400</b>
9400831889	<b>TBK279</b>	9604964880	<b>TB468</b>	9630117480	<b>AH5040</b>	9682013380	<b>AH7310</b>	99432354	<b>BX390</b>
9400831929	<b>TBK338</b>	9605348380	<b>NF867</b>	9630117580	<b>AH5060</b>	9682013580	<b>AH7320</b>	99432652	<b>V91301</b>
9400956489	<b>HR5046</b>	96058570	<b>TB346</b>	9630142380	<b>JM5087</b>	97002474	<b>HBS039</b>	99432717	<b>V91302</b>
94145839	<b>BX040</b>	96058570	<b>TB419</b>	9631366780	<b>AD5490</b>	97506647	<b>HR805</b>	99432718	<b>V91304</b>
9454053	<b>NB946</b>	96059361	<b>V91972</b>	9631366980	<b>AD5500</b>	9750664780	<b>HR805</b>	99432837	<b>V91994</b>
9456002680	<b>BR510</b>	96059362	<b>V91970</b>	9631367180	<b>AD5510</b>	9751080000	<b>NF857</b>	99433965	<b>NP067</b>
9456033280	<b>BM530</b>	96059994	<b>HBS087</b>	9631367380	<b>AD5520</b>	9751080080	<b>NF857</b>	99442951	<b>HBS255</b>
9456043880	<b>JC423</b>	96065269	<b>NF817</b>	9631424480	<b>JD5881</b>	97510801	<b>NF870</b>	9944352	<b>DS381</b>
9456043980	<b>JD5972</b>	96073848	<b>HBS084</b>	9632372480	<b>FOL190</b>	97510802	<b>NF817</b>	99447458	<b>NF883</b>
9463330180	<b>JM7121</b>	96075122	<b>BL650</b>	9632959380	<b>TB727</b>	97523053	<b>JN658</b>	99453418	<b>NF883</b>
9463377480	<b>JM5139</b>	96079213	<b>V94170</b>	9633089580	<b>FOL150</b>	97531044	<b>V91273</b>	99453418	<b>NF885</b>
9463377580	<b>JM5283</b>	9608064880	<b>JP045</b>	9633923080	<b>TB479</b>	97531080	<b>V91271</b>	99456476	<b>TB368</b>
9463380180	<b>TB678</b>	96100168	<b>TB346</b>	9633923180	<b>TB479</b>	97531278	<b>HR599</b>	99456477	<b>TB558</b>
9463380380	<b>JM5141</b>	96100168	<b>TB419</b>	9634437580	<b>V94491</b>	97531278	<b>HR646</b>	99458402	<b>BX420</b>
9463380680	<b>TB632</b>	96105057	<b>JC991</b>	96350076	<b>TB683</b>	9753127800	<b>HR599</b>	99460983	<b>BX410</b>
9464034380	<b>TB720</b>	9610505780	<b>JC759</b>	9635007680	<b>TB683</b>	9753127880	<b>HR646</b>	99461498	<b>AY580</b>
9464396380	<b>FOL190</b>	96109183	<b>V94170</b>	9635007780	<b>TB683</b>	97531988	<b>HR646</b>	99461499	<b>AY590</b>
9464464980	<b>TB683</b>	96133146	<b>BL650</b>	9635317980	<b>V94438</b>	9753198880	<b>HR646</b>	99462588	<b>JP069</b>

# OE INTERCHANGE

OE-Vergleichsliste • Intercambio con OE  
Références croisées 1ère Monte

OE	OE	OE	OE
99468744	<b>NF883</b>	SE700006121B	<b>BG820</b>
99477116	<b>GX410</b>	SE700006121C	<b>BG830</b>
99477119	<b>DX391</b>	SU00100085	<b>TB631</b>
99477120	<b>DX390</b>	SU00100544	<b>TB720</b>
99487487	<b>GX410</b>	SU00100558	<b>FOL190</b>
99488483	<b>JJ519</b>	SZ00100083	<b>CAM373</b>
9M506051AA	<b>AH7290</b>	V97DD6051AA	<b>AY400</b>
9M506051BA	<b>AH7300</b>	V97DD6051BA	<b>AY420</b>
9M506051CA	<b>AH7310</b>	V97DD6051CA	<b>AY410</b>
9M506051DA	<b>AH7320</b>	X039442760	<b>HR646</b>
9S516659EA	<b>NA5057</b>	X03962184	<b>HR805</b>
A133798	<b>V91622</b>	XS7Q6385AB	<b>NA5030</b>
A133799	<b>V91623</b>	XS7Q6571AD	<b>HR5082</b>
A134957	<b>V91629</b>	Y40112101A	<b>FOL190</b>
A134958	<b>V91630</b>	Y40112205	<b>TB720</b>
A850X6014AUA	<b>DM530</b>	Y40112205A	<b>TB720</b>
A850X6014CBA	<b>DM710</b>	Y40113460	<b>JD5829</b>
A850X6014CCA	<b>DP070</b>	Y60110235	<b>JM7034</b>
A850X6014CDA	<b>DP130</b>	Y60112205	<b>TB724</b>
A850X6014CKA	<b>DP190</b>	ZC9000271	<b>DM530</b>
A850X6014DUA	<b>DP011</b>		
A850X6014EFA	<b>DP110</b>		
A850X6014HEA	<b>DM530</b>		
A850X6014JCA	<b>DJ852</b>		
A850X6014JHA	<b>DG811</b>		
A850X6051RA	<b>BG820</b>		
A850X6051SA	<b>BG830</b>		
A850X6584AEA	<b>JN283</b>		
A850X6584AGA	<b>JM085</b>		
A850X6584AKA	<b>JM333</b>		
A850X6584AMA	<b>JN244</b>		
A850X6584BCA	<b>JM663</b>		
A850X6584DDA	<b>JN459</b>		
A850X6584EEA	<b>JN462</b>		
AEU2078L	<b>HBS105</b>		
AEU2078L	<b>HBS106</b>		
AEU2078L	<b>HBS107</b>		
AEU2078L	<b>HBS186</b>		
AEU2083	<b>HBS105</b>		
AEU2083L	<b>HBS105</b>		
AEU2083L	<b>HBS106</b>		
AEU2083L	<b>HBS107</b>		
AEU2085L	<b>HBS105</b>		
AEU2085L	<b>HBS106</b>		
AEU2085L	<b>HBS107</b>		
AJM4460	<b>JN581</b>		
BAU5092	<b>BK580</b>		
BAU5093	<b>BP260</b>		
BAU5094	<b>BK570</b>		
BL18T1007040	<b>FOL190</b>		
D176404A2	<b>HR397</b>		
GEG1257	<b>DK570</b>		
LBUS5825	<b>TB175</b>		
LGR10002	<b>FOL106</b>		
LGR100100	<b>FOL106</b>		
LHN10013	<b>TB175</b>		
LHN10013	<b>TB560</b>		
LHN10015	<b>TB175</b>		
LHN10015	<b>TB560</b>		
LHN100310B	<b>TB175</b>		
LUF100540	<b>NA5104</b>		
LUF100540L	<b>NA5104</b>		
MN960097	<b>FOL190</b>		
N0138452	<b>PA349</b>		
RTC4892	<b>JN581</b>		
SE020000020A	<b>GP011</b>		
SE020000032A	<b>DP011</b>		
SE020004000A	<b>HC027</b>		
SE039442760	<b>HR646</b>		
SE039442760A	<b>HR599</b>		
SE700004221A	<b>JJ136</b>		



# VALVE GUIDES

Ventil Führung • Guia De Valvulas • Guides De Soupape  
 Guide Valvola • Prowadnice zaworów  
 Направляющие Клапанов • دليل الصمام



	F (mm)	G (mm)	E (mm)	
VAG96271B	6.000	11.060	40.000	VG3
VAG96272	6.020	10.030	39.700	VG3
VAG96119	6.030	10.540	41.500	VG1
VAG92364	7.000	13.070	42.500	VG3
VAG92401	7.010	13.060	47.500	VG3
VAG96188B	7.020	12.090	40.050	VG3
VAG96218	7.020	12.090	40.500	VG3
VAG96145	7.020	13.030	46.000	VG3
VAG96123	7.020	13.050	42.250	VG3
VAG96273	7.020	13.060	40.000	VG3
VAG96230	7.020	13.060	46.000	VG3
VAG96132	7.030	13.110	47.600	VG3
VAG92496	7.030	14.040	51.000	VG1
VAG96197B	7.040	12.080	38.000	VG3
VAG96184	7.040	12.080	43.000	VG3
VAG50895	7.040	13.030	46.000	VG1
VAG96146	7.040	13.050	42.500	VG3
VAG96229	7.040	13.080	42.500	VG3
VAG96181B	7.040	14.050	51.300	VG3
VAG96199	7.040	14.080	51.300	VG3
VAG92444	8.000	13.040	56.00	VG3
VAG92445	8.000	13.040	60.00	VG1
VAG92369	8.000	13.070	60.000	VG1
VAG51007	8.000	14.060	55.000	VG3
VAG92366	8.000	14.100	46.500	VG3
VAG96268	8.000	15.070	45.000	VG3
VAG96260B	8.000	15.070	48.000	VG3
VAG586	8.010	12.760	62.000	VG1



**VG1**



**VG2**

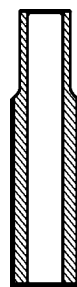

**VG3**



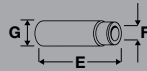

	F (mm)	G (mm)	E (mm)	
VAG92332B	8.020	13.070	38.700	VG3
VAG96261	8.020	13.080	40.500	VG3
VAG96047	8.020	13.090	43.500	VG3
VAG96215B	8.020	13.090	54.500	VG3
VAG96171	8.020	14.060	42.000	VG3
VAG96124	8.020	14.060	42.900	VG3
VAG96187	8.020	14.060	55.000	VG3
VAG96160B	8.020	14.090	48.000	VG1
VAG96100	8.020	14.370	48.000	VG3
VAG701	8.030	12.770	54.000	VG1
VAG92373	8.030	13.040	56.000	VG3
VAG96056B	8.030	13.070	45.000	VG3
VAG96116B	8.030	13.580	45.000	VG3
VAG92465B	8.030	14.070	52.000	VG2
VAG96203	8.030	14.080	43.000	VG1
VAG92331B	8.030	14.080	50.000	VG1
VAG92288B	8.030	14.280	52.000	VG2
VAG92193	8.040	13.050	56.000	VG1
VAG92194	8.040	13.050	60.000	VG1
VAG92497	8.040	14.030	56.000	VG1
VAG96210	8.040	14.040	43.000	VG3
VAG51023B	8.040	15.040	47.000	VG1
VAG50879	8.050	14.040	48.000	VG1
VAG96263	9.000	14.050	48.500	VG3
VAG92168B	9.000	14.050	51.000	VG1
VAG96267	9.000	14.060	42.500	VG3
VAG96262	9.000	14.060	48.500	VG3
VAG96216B	9.010	14.050	54.000	VG3

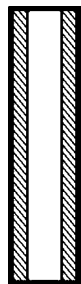

**VG1**

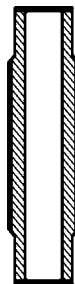







**VG2**









**VG3**

# OIL SEALS







Öldichtungen • Albero a camme • Bagues d'étanchéité  
Retenes de aceite • Uszczelnienia olejowe  
Сальники • لعمود الكام

													
23.00	x	35.00	x	7.00	FPM	829S RD	↻						NB815
27.00	x	37.00	x	7.00	FPM	829S RD W	↻						NA5057
27.00	x	47.00	x	7.00	FPM	827S RD W	↻						NA5035
27.00	x	47.00	x	7.00	PTFE	827S RD W	↻						NA5258
28.00	x	42.00	x	7.00	FPM	827S RD	↻						NB866
30.00	x	42.00	x	7.00	FPM	827S RD W	↻						NA5053
30.00	x	43.00	x	8.00	ACM	829S RD W	↻						NB742
30.00	x	43.00	x	8.00	FPM	829S RD W	↻						NB825
30.00	x	52.00	x	7.00	ACM	827S RD	↻						NA5187
31.00	x	41.00	x	7.00	FPM	829S RD W	↻						NA5070
31.00	x	55.00	x	7.00	FPM	829S RD W	↻						NA5321
31.50	x	42.00	x	7.00	FPM	829S RD W	↻						NA5174
32.00	x	47.00	x	10.00	FPM	827S DD W	↻						NA5001
32.00	x	47.00	x	10.00	FPM	827S RD W	↻						NA5163
32.00	x	50.00	x	8.00	FPM	829S RD W	↻						NJ951
34.00	x	60.00	x	10.00	FPM	829S RD W	↻						NA5201
35.00	x	48.00	x	7.00	MVQ	829S RD W	↻						NC006
35.00	x	50.00	x	10.00	ACM	827S RD W	↻						NA5066
35.00	x	50.00	x	10.00	MVQ	827S RD	↻						NF722
35.00	x	50.00	x	7.00	FPM	827S RD W	↻						NB959
35.00	x	50.00	x	8.00	FPM	827N DD	↻						NF841
35.00	x	58.00	x	10.00	ACM	827S RD W	↻						NA5064
36.00	x	50.00	x	7.00	FPM	827S RD W	↻						NF817
38.00	x	50.00	x	6.00	FPM	827S RD W	↻						NA5260
40.00	x	52.00	x	7.00	FPM	829S RD W	↻						NA5223
40.00	x	55.00	x	6.50	FPM	827S RD W	↻						NA5256
40.00	x	55.00	x	7.00	FPM	827S RD	↻						NA5058
40.00	x	56.00	x	10.00	ACM	822S RD	↻						NA5063
40.00	x	56.00	x	7.00	FPM	827N	↻						NA5051
40.00	x	56.00	x	7.00	ACM	822N RD	↻						NB818
42.00	x	55.00	x	7.00	FPM/ACM	827S RD W	↻						NA5108
42.00	x	56.00	x	7.00	FPM	829S RD W	↻						NA5177
42.00	x	62.00	x	7.00	PTFE	829S RD W	↻						NA5191
42.00	x	66.00	x	6.00	FPM/ACM	827S RD W	↻						NF870
50.00	x	70.00	x	10.00	FPM	829S RD W	↻						NP067
50.00	x	80.00	x	14.00	FPM	SP	↻						NA5202
50.00	x	86.50	x	13.70	PTFE	SP	↻						NA5031
53.00	x	68.00	x	10.00	ACM	827N LD	↻						NA5045
53.00	x	68.00	x	10.00	ACM	827N	↻						NB728
55.00	x	68.00	x	8.00	FPM	829S RD W	↻						NA5069
55.00	x	70.00	x	8.00	FPM	827S RD W	↻						NP068
62.00	x	80.00	x	12.00	ACM	822N LD	↻						NA5065
64.00	x	80.00	x	8.00	ACM	822S LD	↻						NA5049
64.00	x	80.00	x	8.00	FPM	829S LD W	↻						NB808
64.00	x	112.50	x	20.00	FPM	840	↻						NF887
70.00	x	85.00	x	8.00	FPM	822N LD	↻						NA5052
70.00	x	88.00	x	8.00	FPM	829S LD W	↻						NB814
70.00	x	90.00	x	10.00	ACM	827S	↻						NA5050
70.00	x	90.00	x	10.00	FPM	829S RD W	↻						NA5055
70.00	x	90.00	x	10.00	ACM	827N LD	↻						NA784
70.00	x	90.00	x	10.00	FPM	829S RD W	↻						NB946
70.00	x	159.00/179.00	x	16.00	FPM	840S RD	↻						NF885

													
74.00	x	88.00	x	8.00	FPM	829S LD W							NA5061
74.00	x	90.00	x	10.00	NBR	829 S W							NB644
74.00	x	90.00	x	10.00	FPM	829S LD W							NB732
74.00	x	187.50	x	17.000	FPM								LK5001
78.00	x	100.00	x	9.00	PTFE	827S RD W							NA5230
80.00	x	98.00	x	10.00	FPM	827S LD W							NB698
85.00	x	105.00	x	8.80	PTFE	827S LD W							NA5325
85.00	x	105.00	x	9.00	FPM/ACM	827S LD W							NF857
85.00	x	105.00	x	11.00	PTFE	829S LD W							NA5305
90.00	x	104.00	x	11.00	FPM	829S LD							NB806
90.00	x	110.00	x	12.00	PTFE	829S LD W							NA5104
90.00	x	110.00	x	7.00	PTFE	829S LD W							NA5192
90.00	x	115.00	x	13.00	FPM	829S LDW							NF833
93.00	x	139.70/172.00	x	12.00	FPM	840S LD							NF888
98.00	x	120.00	x	7.00	FPM/ACM	827S LD							NF867
100.00	x	118.00	x	10.00	FPM	829S LD W							NF853
100.00	x	179.00	x	15.80	FPM	840S LD							NF886
106.00	x	190.00/196.00	x	15.20	FPM	841S LD							NA5030
114.00	x	171.00/177.00	x	13.00	FPM	840S LD							NF883





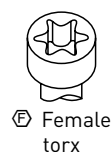
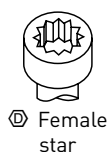
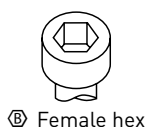

# CYLINDER HEADBOLTS

Zylinderkopfschrauben • Viti testa Cilindro • Vis de culasse  
Tornillo • Śruba głowicowa  
Болты ГБЦ • مسمار الرأس

	Component Reference				QTY		
HBS011	HB028-BA	M12	1.25	163.00	10	Ⓛ	
HBS011	HB029-BA	M12	1.25	119.00	12	Ⓛ	
HBS017	HB034-BA	M12	1.50	118.00	9	Ⓐ	
HBS017	HB035-BA	M12	1.50	146.00	8	Ⓐ	
HBS033	HB098-BA	M12	1.75	136.00	10	Ⓕ	
HBS038	HB037-BA	M11	1.50	175.00	10	Ⓕ	
HBS039	HB081-BA	M10	1.50	175.00	10	Ⓔ	
HBS051	HB082-BA	M10	1.25	84.00	5	Ⓐ	
HBS051	HB083-BA	M10	1.25	98.00	5	Ⓐ	
HBS052	HB085-BA	M9	1.25	95.00	10	Ⓛ	
HBS055	HB199-BA	M10	1.25	153.00	10	Ⓔ	
HBS084	HB033-BA	M12	1.50	120.00	10	Ⓕ	
HBS087	HB093-BA	M12	1.50	110.00	10	Ⓔ	
HBS092	HB087-BA	M10	1.25	115.00	10	Ⓚ	
HBS093	HB090-BA	M10	1.25	172.00	10	Ⓚ	
HBS095	HB084-BA	M12	1.25	133.00	10	Ⓚ	
HBS097	HB126-BA	M12	1.25	120.00	10	Ⓚ	
HBS098	HB514-BA	M12	1.25	140.00	5	Ⓐ	
HBS098	HB515-BA	M10	1.25	116.00	5	Ⓐ	
HBS105	HB018-BA	M14	2.00	137.00	10	Ⓓ	
HBS105	HB019-BA	M12	1.75	116.00	4	Ⓓ	
HBS105	HB020-BA	M12	1.75	80.00	4	Ⓓ	
HBS106	HB018-BA	M14	2.00	137.00	12	Ⓐ	
HBS106	HB019-BA	M12	1.75	116.00	5	Ⓐ	
HBS106	HB020-BA	M12	1.75	80.00	5	Ⓐ	
HBS107	HB018-BA	M14	2.00	137.00	8	Ⓐ	
HBS107	HB019-BA	M12	1.75	116.00	3	Ⓐ	
HBS107	HB020-BA	M12	1.75	80.00	3	Ⓐ	
HBS108	HB104-BA	M14	2.00	137.00	10	Ⓓ	
HBS108	HB105-BA	M12	1.75	79.50	4	Ⓓ	
HBS108	HB106-BA	M12	1.75	115.00	4	Ⓓ	
HBS125	HB040-BA	M12	1.50	150.50	10	Ⓕ	
HBS130	HB200-BA	M10	1.25	163.00	10	Ⓚ	



\*Ribe-CV® is a registered trademark of Richard Bergner GmbH & Co.

	Component Reference				QTY		
HBS131	HB201-BA	M10	1.25	100.00	10	Ⓚ	
HBS132	HB203-BA	M10	1.25	254.00	10	Ⓚ	
HBS133	HB203-BA	M10	1.25	254.00	12	Ⓚ	
HBS227	HB204-BA	M12	1.25	218.00	fhbs405	Ⓚ	
HBS245	HB240-BA	M12	1.50	125.00	10	ⓔ	
HBS247	HB242-BA	M9	1.25	87.00	10	Ⓚ	
HBS251	HB247-BA	M14	1.50	193.00	6	ⓔ	
HBS251	HB272-BA	M11	1.50	133.00	4	ⓔ	
HBS255	HB028-BA	M12	1.25	160.00	14	ⓓ	
HBS255	HB250-BA	M12	1.25	90.00	8	ⓓ	
HBS257	HB204-BA	M12	1.25	218.00	12	Ⓚ	
HBS259	HB256-BA	M11	1.50	144.50	10	ⓔ	
HBS260	HB257-BA	M11	1.50	168.00	10	ⓔ	
HBS261	HB258-BA	M12	1.50	126.00	10	ⓔ	
HBS262	HB243-BA	M10	1.25	220.00	10	Ⓚ	
HBS272	HB269-BA	M10	1.50	147.00	16	ⓔ	
HBS277	HB488-BA	M12	1.50	148.00	10	ⓔ	
HBS279	HB276-BA	M11	1.50	154.00	6	ⓓ	
HBS279	HB521-BA	M11	1.50	109.00	4	ⓓ	
HBS297	HB331-BA	M9	1.25	56.00	1	ⓓ	
HBS297	HB332-BA	M9	1.25	91.00	9	ⓓ	
HBS353	HB338-BA	M10	1.25	119.00	10	Ⓚ	
HBS359	HB341-BA	M11	1.50	147.00	10	ⓔ	
HBS370	HB354-BA	M12	1.25	225.00	10	Ⓚ	
HBS371	HB354-BA	M12	1.25	225.00	12	Ⓚ	
HBS416	HB416-BA	M11	1.50	163.00	10	ⓓ	
HBS464	HB422-BA	M15	1.50	193.00	6	ⓔ	✓
HBS464	HB423-BA	M8	1.25	117.00	4	ⓔ	✓
HBS464	HB424-BA	M12	1.50	165.00	4	ⓔ	✓
HBS464	HB425-BA	M8	1.25	58.00	1	ⓔ	✓
HBS465	HB426-BA	M12	1.50	220.00	10	Ⓚ	
HBS497	HB444-BA	M10	1.50	149.00	10	ⓐ	
HBS535	HB552-BA	M11	1.50	128.00	10	ⓔ	

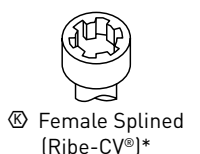
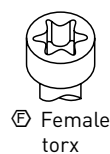
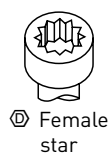
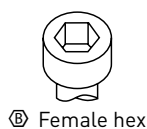

\*Ribe-CV® is a registered trademark of Richard Bergner GmbH & Co.

# TECHNICAL NOTES

Technische Hinweise • Notes techniques  
Note tecniche • Notas técnicas

English

- |    |                                    |
|----|------------------------------------|
| 1  | Without crankshaft seal            |
| 2  | With cylinder sleeve ring          |
| 3  | Specification: Contains JJ449      |
| 4  | Specification: LEM                 |
| 5  | Specification: Edge Moulded        |
| 6  | Mechanical                         |
| 7  | Camshaft driven vacuum pump.       |
| 8  | Pulley driven vacuum pump.         |
| 9  | Includes seals                     |
| 10 | Liner available in Kit Set only    |
| 11 | Nitrided                           |
| 12 | Piston available in Kit Set only   |
| 13 | Piston Chamber Volume [ccm] 19.91  |
| 14 | Ringset available in Kitset only   |
| 15 | Steel                              |
| 16 | Use also: 1 NB O-Ring HR566        |
| 17 | Without circlips                   |
| 18 | Outer Diameter 1 [mm]: 105.00      |
| 19 | Specification: Oil Seal in housing |
| 20 | Oil Pan Material: Steel            |
| 21 | "SPUTTER" upper half bearing       |
| 22 | G-188                              |
| 23 | G-488                              |

Deutsch

1 Ohne Kurbelwellen-Dichtring

2 Mit Zylinderbuchsenring

3 Spezifikation: Enthält JJ449

4 Spezifikation: LEM

5 Spezifikation: Angeformter Rand

6 Mechanisch

7 Unterdruckpumpe mit Nockenwellenantrieb.

8 Unterdruckpumpe mit Riemenscheibenantrieb.

9 Einschließlich Dichtringen

10 Laufbuchse nur im Satz erhältlich

11 Nitriergehärtet

12 Kolben nur im Satz erhältlich

13 Kolbenraumvolumen [ccm] 19,91

14 Kolbenringsatz nur im Satz erhältlich

15 Stahl

16 Auch zu verwenden: 1 NB O-Ring HR566

17 Ohne Sicherungsringe

18 Außendurchmesser 1 [mm]: 105,00

19 Spezifikation: Öldichtung im Gehäuse

20 Material Ölwanne: Stahl

21 „Sputter“ obere Lagerhälfte

22 G-188

23 G-488

1 Senza paraolio-albero a gomito

2 Con anello tenuta canna cilindro

3 Specifiche: Contiene JJ449

4 Specifiche: LEM

5 Specifiche: Con bordo di tenuta stampato direttamente sulla lamiera di supporto

6 Meccanica

7 Pompa del vuoto azionata dall'albero a camme

8 Pompa del vuoto azionata dalla puleggia

9 Con guarnizioni

10 Camicia disponibile solo nel Kit

11 Nitrurato

12 Pistone disponibile solo nel Kit

13 Volume Camera Pistone [cc] 19,91

14 Segmenti disponibili solo nel Kit

15 Acciaio

16 Usare anche: 1 NB O-Ring HR566

17 Senza seeger

18 Diametro esterno 1 [mm]: 105,00

19 Specifiche: Paraolio in sede

20 Materiale coppa olio: Acciaio

21 Semicuscinetto superiore "SPUTTER"

22 G-188

23 G-488



Français

- |    |   |
|----|---|
| 1  | Sans bague d'étanchéité de vilebrequin                  |
| 2  | Avec segments   |
| 3  | Caractéristiques : Contient JJ449                       |
| 4  | Caractéristiques : LEM                                  |
| 5  | Caractéristiques : Bord moulé                           |
| 6  | Mécanique   |
| 7  | Pompe à vide entraînée par l'arbre à cames              |
| 8  | Pompe à vide entraînée par poulie                       |
| 9  | Bagues d'étanchéité incluses                            |
| 10 | Chemise de piston uniquement disponible en kit          |
| 11 | Nitruré   |
| 12 | Piston uniquement disponible en kit                     |
| 13 | Cylindrée chambre de combustion (cm3) 19,91             |
| 14 | Pochette de segments uniquement disponible              |
| 15 | Acier   |
| 16 | Utiliser également : 1 Joint torique NB HR566           |
| 17 | Sans circlips   |
| 18 | Diamètre extérieur 1 (mm) : 105,00                      |
| 19 | Caractéristiques : Bague d'étanchéité dans son logement |
| 20 | Matériau du carter d'huile: acier                       |
| 21 | Demi-coussinet supérieur « pulvérisé = sputter »        |
| 22 | G-188   |
| 23 | G-488   |

- |    |   |
|----|---|
| 1  | Sin retén del cigüeñal                                |
| 2  | Con segmento de la camisa de cilindro                 |
| 3  | Especificaciones: Contiene JJ449                      |
| 4  | Especificaciones: LEM                                 |
| 5  | Especificaciones: Borde moldeado                      |
| 6  | Mecánica  |
| 7  | Bomba de vacío accionada por árbol de levas           |
| 8  | Bomba de vacío accionada por polea                    |
| 9  | Incluye juntas  |
| 10 | Camisa disponible únicamente en el kit                |
| 11 | Nitrurado   |
| 12 | Pistón disponible únicamente en el kit                |
| 13 | Volumen de la cámara del pistón (cilindrada) 19,91    |
| 14 | Conjunto de segmentos disponible únicamente en el kit |
| 15 | Acero   |
| 16 | Utiliza también: Junta tórica 1 NB HR566              |
| 17 | Sin arandelas de retención                            |
| 18 | Diámetro exterior 1 (mm): 105,00                      |
| 19 | Especificaciones: Retén de aceite de la carcasa       |
| 20 | Material del cárter de aceite: Acero                  |
| 21 | Mitad del rodamiento superior "SPUTTER"               |
| 22 | G-188   |
| 23 | G-488   |

Polski

1	Bez uszczelnienia wału korbowego
2	Z pierścieniem tulei cylindrowej
3	Specyfikacja: Zawiera JJ449
4	Specyfikacja: LEM
5	Specyfikacja: Wyprofilowana krawędź
6	Mechaniczne
7	Pompa podciśnieniowa napędzana wałkiem rozrządu.
8	Pompa podciśnieniowa napędzana kołem pasowym.
9	Zawiera uszczelnienia
10	Tuleja dostępna tylko w zestawie
11	Azotowany
12	Tłok dostępny tylko w zestawie
13	Objętość komory spalania w tłoku [cm <sup>3</sup> ] 19,91
14	Zestaw pierścieni dostępny tylko w zestawie
15	Stal
16	Użyć również: 1 NB O-Ring HR566
17	Bez pierścieni zabezpieczających
18	Średnica zewnętrzna 1 [mm]: 105.00
19	Specyfikacja: Uszczelnienie olejowe w obudowie
20	Materiał miski olejowej: Stal
21	Górna połowa łożyska typu „SPUTTER”
22	G-188
23	G-488

1 Без сальника коленчатого вала

2 С кольцом гильзы цилиндра

3 Спецификации: Включает JJ449

4 Спецификации: LEM (Литой эластомер на планшете)

5 Спецификации: с защитной кромкой

6 Механический

7 Вакуумный насос с приводом от распределительного вала.

8 Вакуумный насос с приводом от шкива.

9 Уплотнительные кольца - в комплекте

10 Гильза доступна только в комплекте

11 С азотированием поверхности

12 Поршень доступен только в комплекте

13 Объем камеры сгорания поршня [см<sup>3</sup>] 19,91

14 Набор колец доступен только в комплекте

15 Сталь

16 Также используйте: Уплотнительное кольцо 1 NB HR566

17 Без стопорных колец

18 Наружный диаметр 1 [мм]: 105,00

19 Спецификации: Масляное уплотнение в корпусе

20 Материал масляного поддона: Сталь

21 Верхняя половина вкладыша "SPUTTER"

22 G-188

23 G-488

اللغة العربية

1	بدون مانع تسريب عمود المرفق
2	مع حلقات مانعه للتسرب للإسطوانه(القميص)
3	المواصفات: يتضمن JJ449
4	المواصفات: قالب المطاط الصناعي السائل (LEM)
5	المواصفات: حافة مُشكّلة
6	ميكانيكيا
7	مضخة تفريغ تعمل بعمود الكامنة
8	مضخة تفريغ تعمل بالبكرة
9	تتضمن على سدادات
10	البطانة متاحة في مجموعة الطقم فقط
11	بالنيتريد
12	الكباس متاح في مجموعة الطقم فقط
13	سعة غرفة الكباس [سس] 19.91
14	مجموعة الحلقات(الشنابر) متاحة مع طقم التركيب فقط
15	الفولاذ
16	استخدم أيضًا: 1 NB حلقة دائرية HR566
17	بدون حلقات ربط
18	القطر الخارجي 1 [مم]: 105.00
19	المواصفات: سداة الزيت داخل التجويف
20	مادة حوض الزيت: الفولاذ
21	السبائك العلوية من نوع SPUTTER
22	G-188
23	G-488



**Federal-Mogul Global Aftermarket EMEA bvba**

Prins Boudewijnlaan 5 • B-2550 Kontich • Belgium

**Central Distribution Centre**

Prins Boudewijnlaan 7 • B-2550 Kontich • Belgium

Phone +32 (0) 3450 83 10 • Fax +32 (0) 3450 83 38

**Federal-Mogul Italy Srl****Aftermarket Division**

Via Enrico Fermi 8 • 37135 Verona • Italy

Phone +39 045 828 13 11 • Fax +39 045 828 14 00

**Federal-Mogul Germany GmbH**

Albert-Ruprecht-Strasse 2 • 71636 Ludwigsburg • Germany

Phone +49 (0) 7141-64865-8230 • Fax +49 (0) 7141-64865-8390

**Federal-Mogul Aftermarket UK Limited**

Greyhound Drive • Bradford • BD7 1NQ • England

Phone +49 (0) 7141-64865-8230 • Fax: +49 (0) 7141-64865-8390

**Federal-Mogul Ibérica, S.L.****Federal-Mogul Aftermarket España, S.A.**

Calle Alcarria, nº 2 • 28823 Coslada • Madrid • Spain

Phone: + 34 91 746 1900 • Fax: + 34 91 746 18 90

**Federal-Mogul Aftermarket France**

60-62, rue Danjou • 92517 Boulogne-Billancourt Cedex • France

Phone +33 (0) 1 46 94 27 00 • Fax +33 (0) 1 46 94 27 01

**Service Commande de stock :**

Phone +33 (0) 810 000 029 • Fax +32 34 50 80 26

**Service Commande express :**

Phone +33 (0) 810 000 029 • Fax +32 34 50 80 26

**Federal-Mogul Aftermarket****Southern Africa (PTY) Ltd**

33 Western Boulevard • City West • Johannesburg • South Africa

Phone +27 11 630 3000 • Fax +27 11 630 3040

**Federal-Mogul Aftermarket Turkey**

Meclis-i Mebusan Cad. No: 53 Dereli İş Merkezi 34427 • Fındıklı / İstanbul • Türkiye

Phone +90 212 292 6313 • Fax +90 212 292 6260

**Federal-Mogul Aftermarket Russia Ltd**

Smolnaya street 24D, 13th floor • 125445 Moscow • Russia

Phone +7 495 221 50 60 • Fax +7 495 221 50 64



